

# 9605337COM bookcase

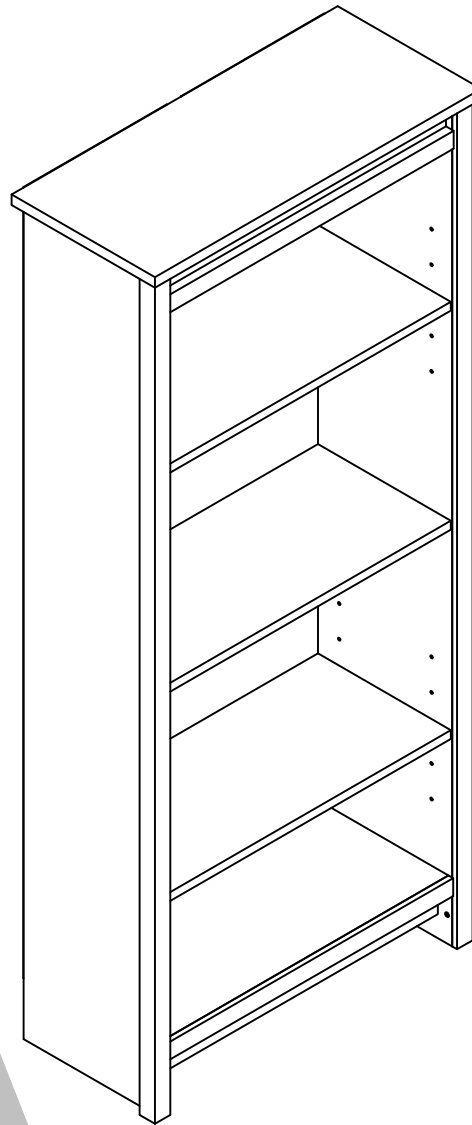

Date of Purchase \_\_\_ / \_\_\_ / \_\_\_  
Lot Number:

B349605337COM0



THIS INSTRUCTION BOOKLET CONTAINS **IMPORTANT** SAFETY INFORMATION. PLEASE READ AND KEEP FOR FUTURE REFERENCE.

### Do Not Return This Product!

Contact our customer service team for help first.

**Call:** 1-800-489-3351 (toll free)

Monday-Friday 9am - 5pm CST

**Visit:** [www.ameriwoodhome.com](http://www.ameriwoodhome.com)



## **WARNING**

- Unit can tip over causing severe injury or death.
- Anchor unit to stud in wall (if instructed to).
- Do Not allow children to climb on unit.
- Put heavy items on lower shelves or drawers.

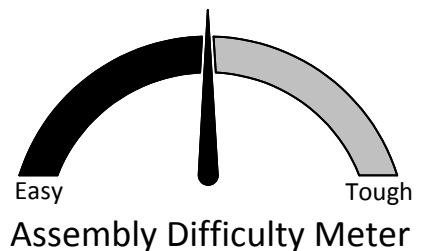

Follow Ameriwood Home



## Contact Us!

### Do NOT return this product!

Contact our friendly customer service team first for help.

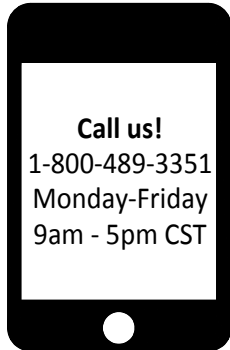

Visit [ameriwoodhome.com](http://ameriwoodhome.com) to view the limited warranty valid in the U.S. and Canada.

Assembly Tips



## Helpful Hints

PEOPLE NEEDED FOR ASSEMBLY: **1-2**  
ESTIMATED ASSEMBLY TIME: **1 HOUR**

- Open your item in the area you plan to keep it to avoid excessive heavy lifting.
- Identify, sort and count the parts before attempting assembly.
- Compression dowels are lightly tapped in with a hammer.
- Slides are labeled with a **R** (right) and **L** (left) for proper placement.
- Make sure to always face the point on the top of the Cam Lock towards the outer edge.
- Use all the nails provided for the back panel and spread them out equally.
- Back panel must be used to make sure your unit is sturdy.
- Do NOT use harsh chemicals or abrasive cleaners on this item.
- Never push, pull, or drag your furniture.



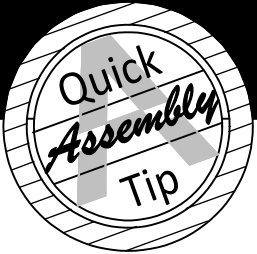

## Before You Start

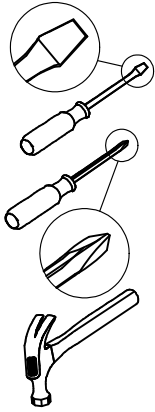

- ✓ Read through each step carefully and follow the proper order
- ✓ Separate and count all your parts and hardware
- ✓ Give yourself enough room for the assembly process
- ✓ Have the following tools: Flat Head Screwdriver, #2 Phillips Head Screwdriver and Hammer
- ✓ Caution: If using a power drill or power screwdriver for screwing, please be aware to slow down and stop when screw is tight. Failure to do so may result in stripping the screw.

## Cam Lock Fastening System

This Cam Lock Fastening System will be used throughout the assembly process.

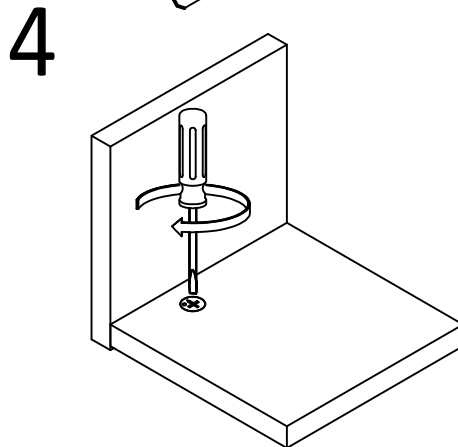
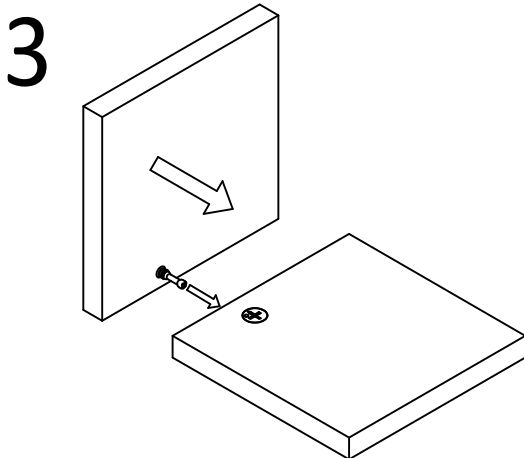
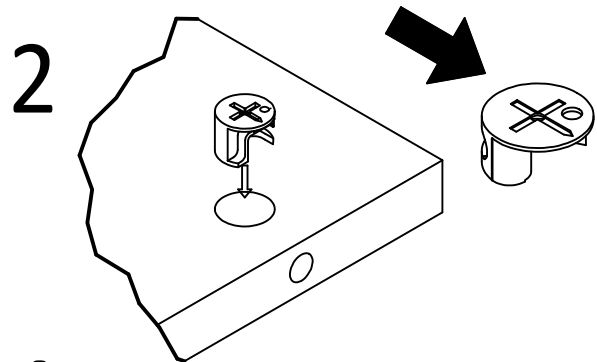
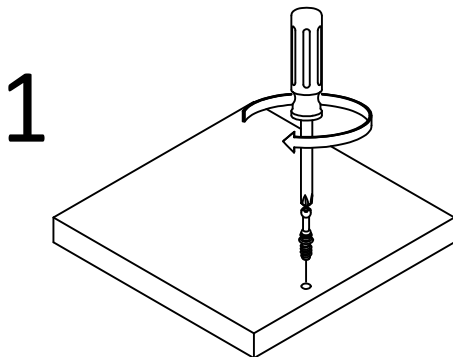

# Board Identification

Not actual size

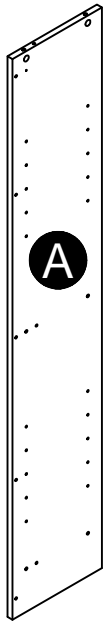

Left Panel  
39605337010

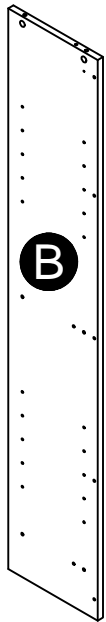

Right Panel  
39605337020

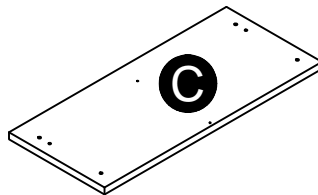

Top  
39605337030

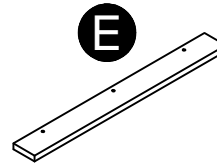

Upper Apron  
39605337050

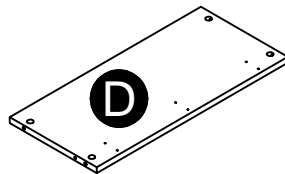

Bottom  
39605337040

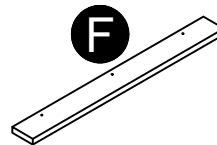

Lower Apron  
39605337060



x2  
Vertical Molding  
39605337070

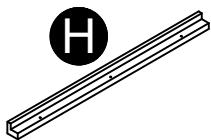

Upper Molding  
39605337080

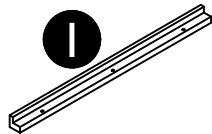

Lower Molding  
39605337090

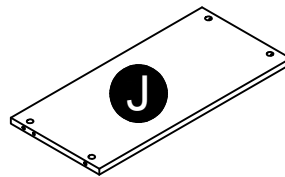

Fixed Shelf  
39605337100

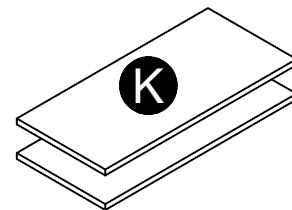

X2  
Adjustable Shelf  
39605337110

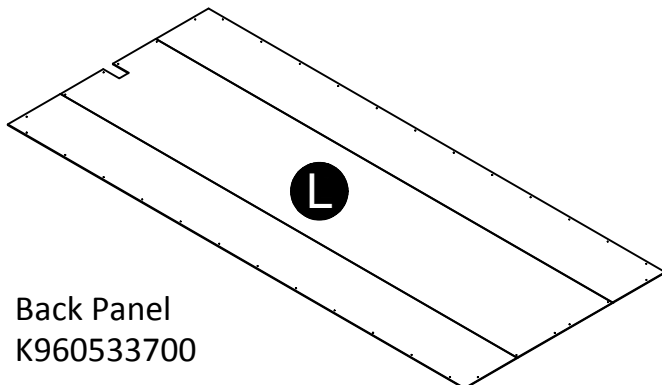

Back Panel  
K960533700

This piece is paperboard construction. It is not made from wood, but is required for the assembly of your unit.

# Board Identification

Not actual size

This piece is paperboard construction.  
It is not made from wood, but is  
required for the assembly of your unit.

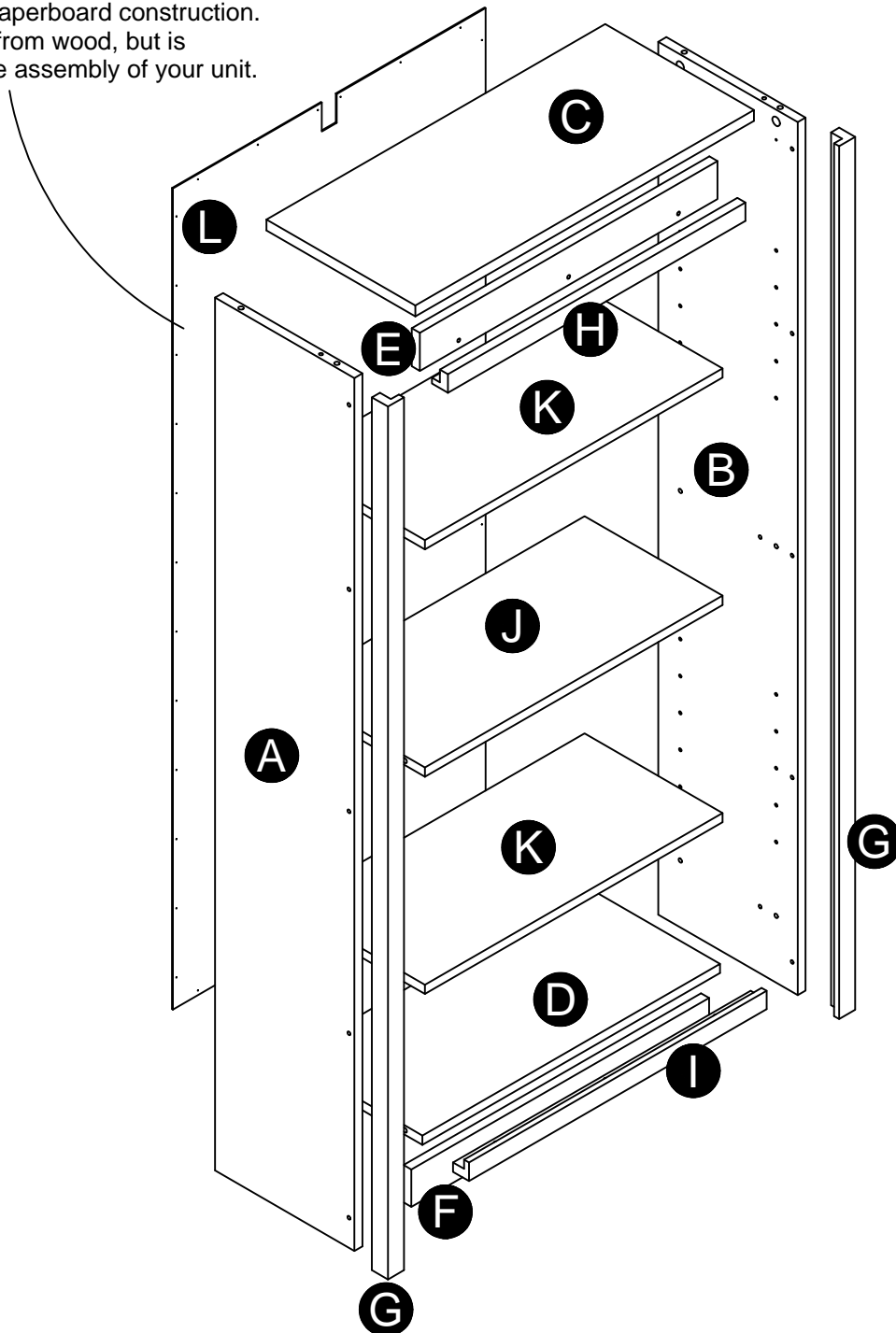

# Part List

## Actual Size



(x12)  
#A22570  
cam lock

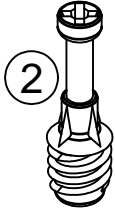

(x12)  
#A22510  
cam bolt

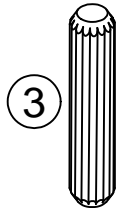

(x6)  
#A21660  
wood dowel

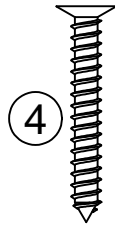

(x16)  
#A12955  
1-1/8" flat head

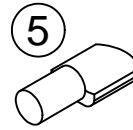

(x8)  
#A80250  
shelf support

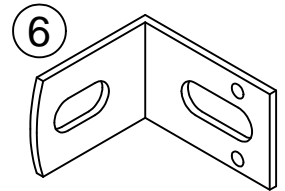

(x6)  
#A53600  
angle bracket



(x12)  
#A12210  
#8 x 1/2" pan head

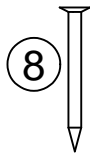

(x36)  
#A21110  
nail

## Not Actual Size

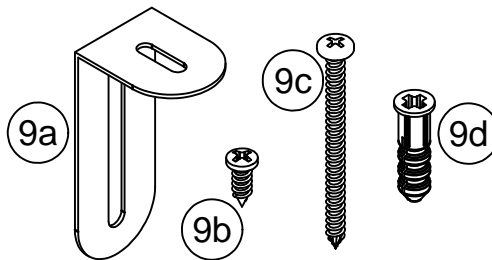

(x1)  
#A84050  
safety bracket kit

# STEP 1

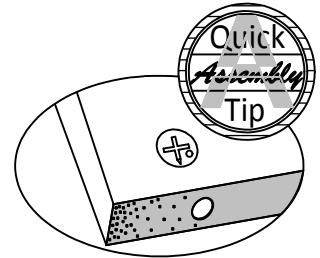
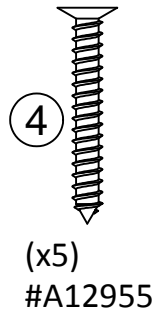
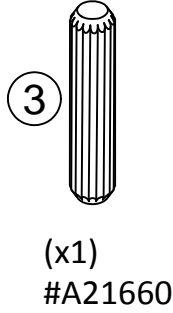
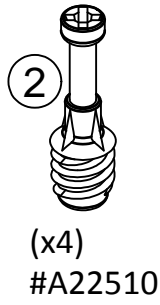
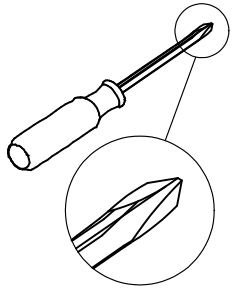

Proper orientation of CAM LOCK

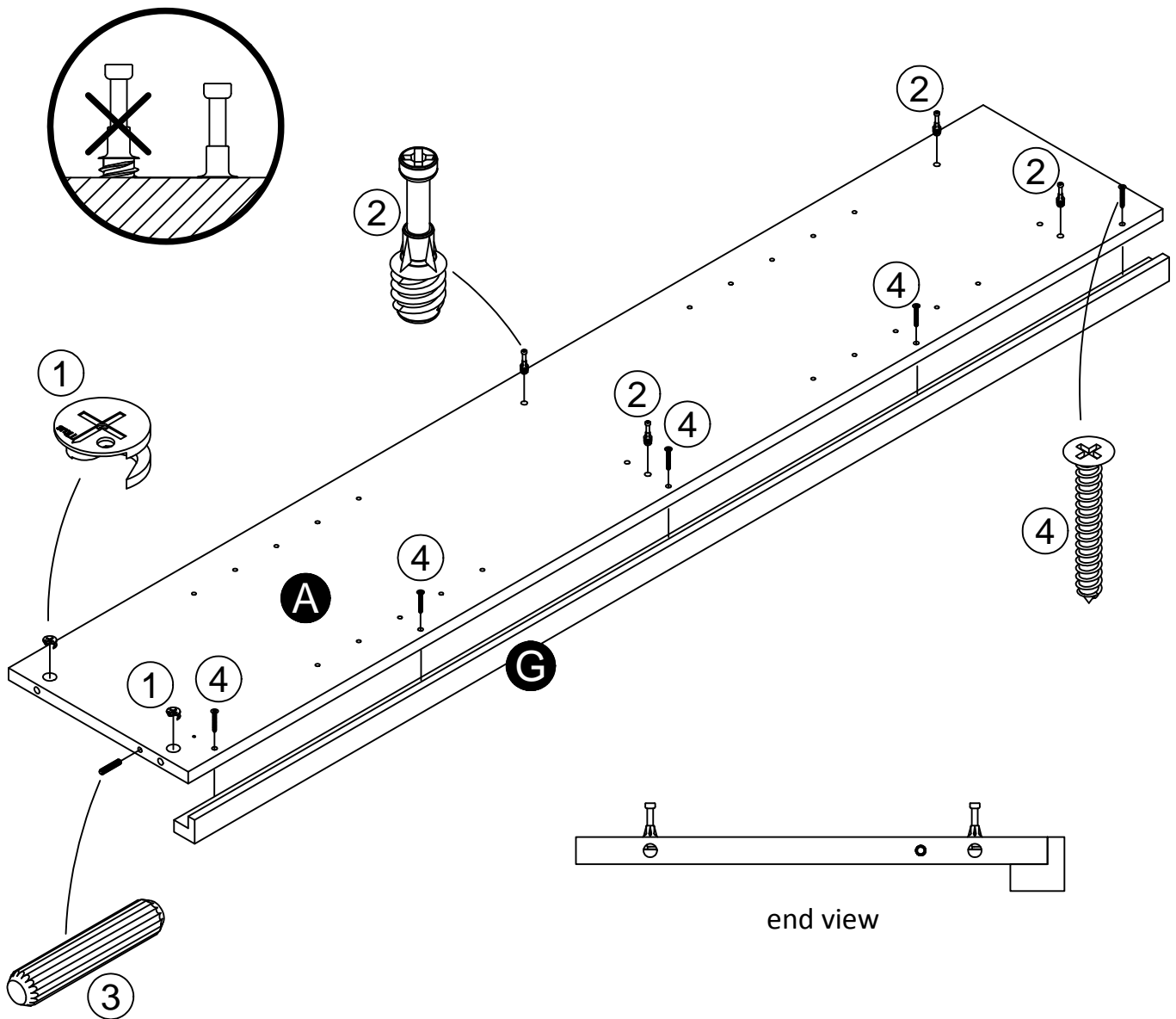

# STEP 2

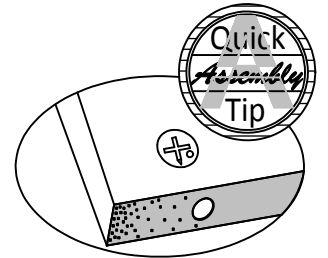
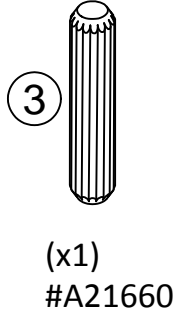
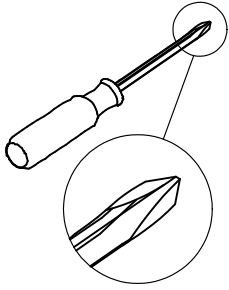

Proper orientation of CAM LOCK

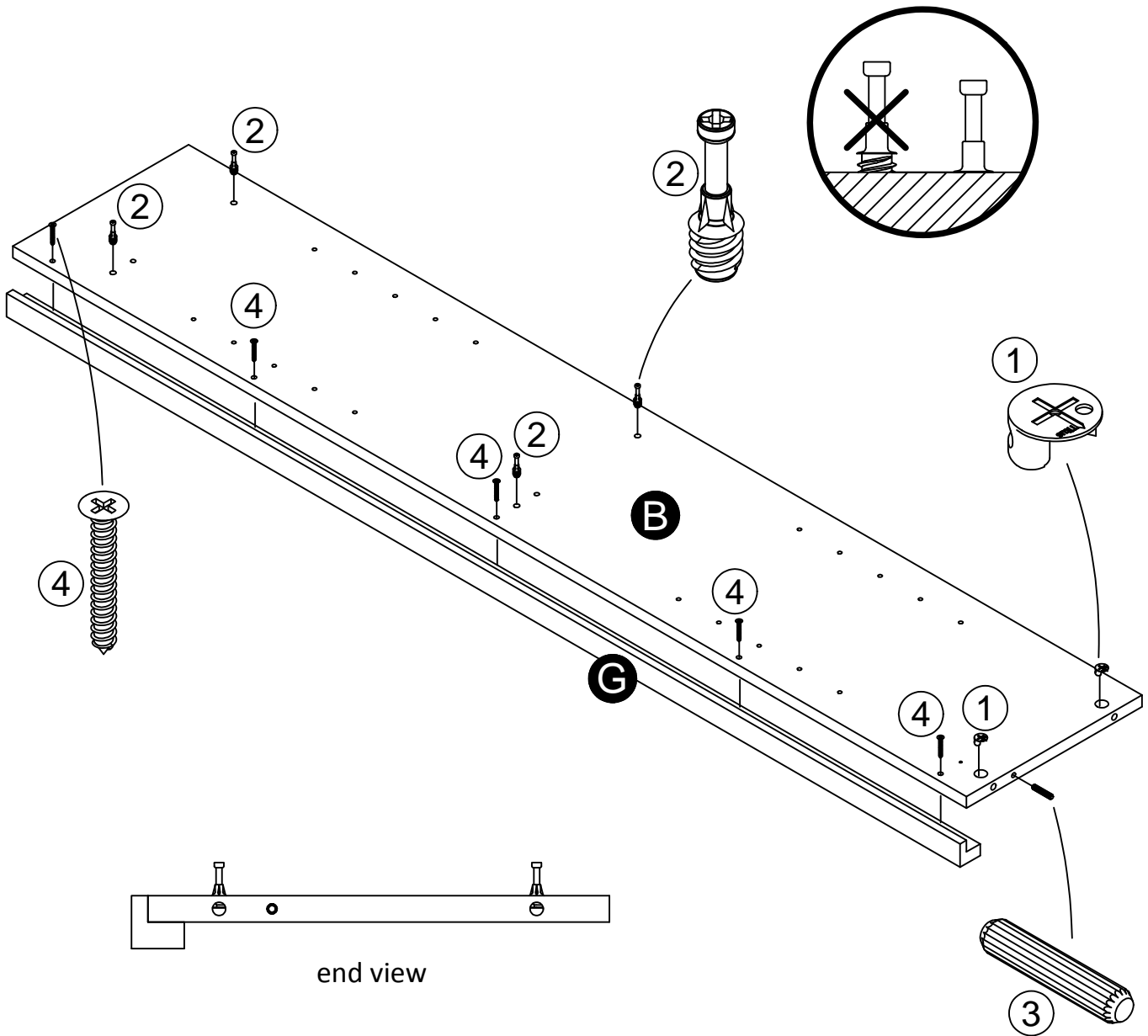



# STEP 3

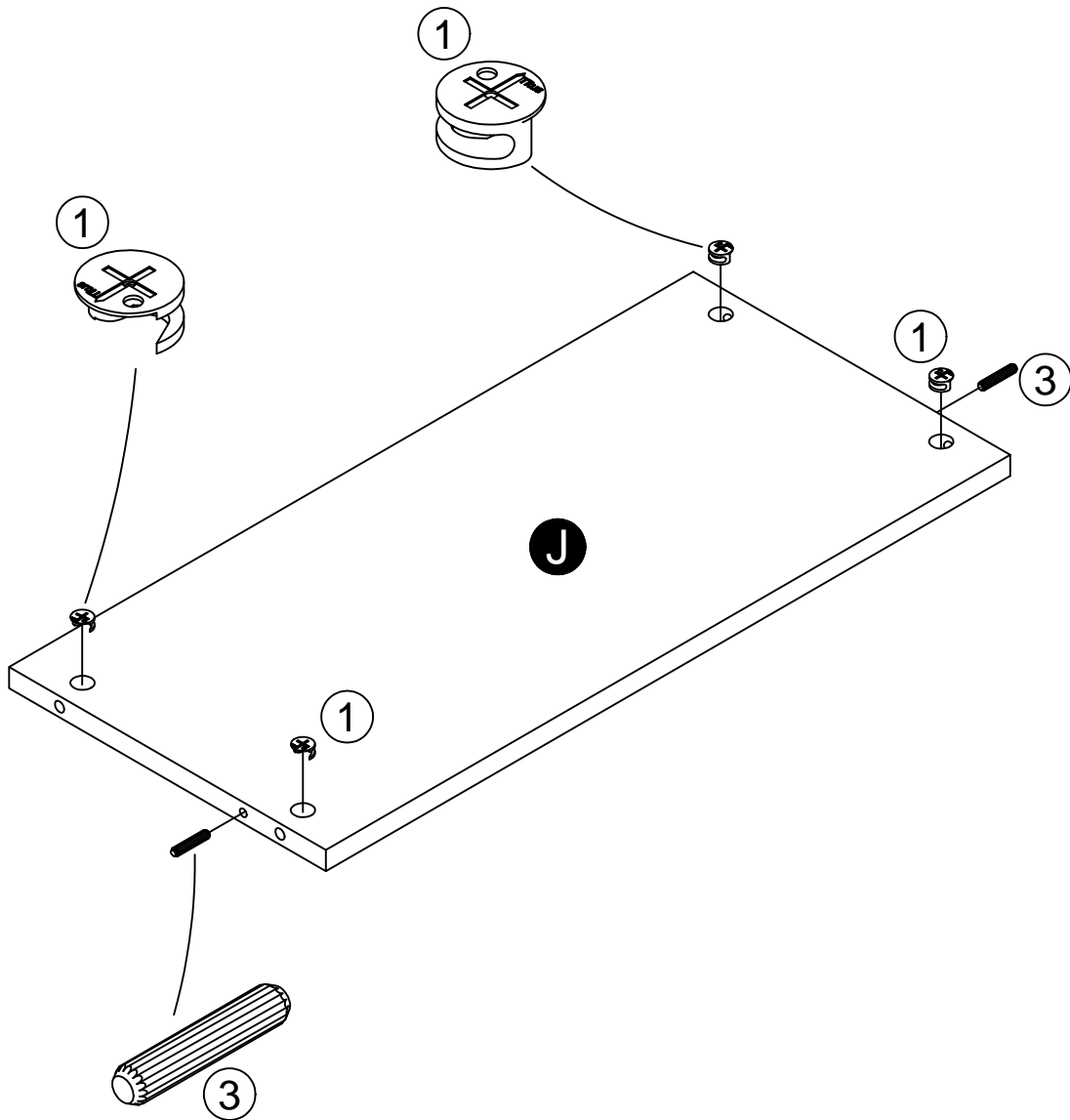
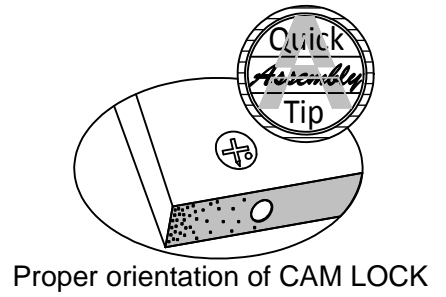
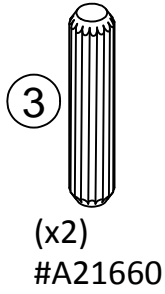
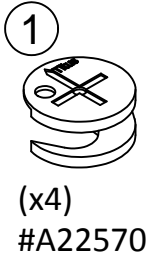

# STEP 4

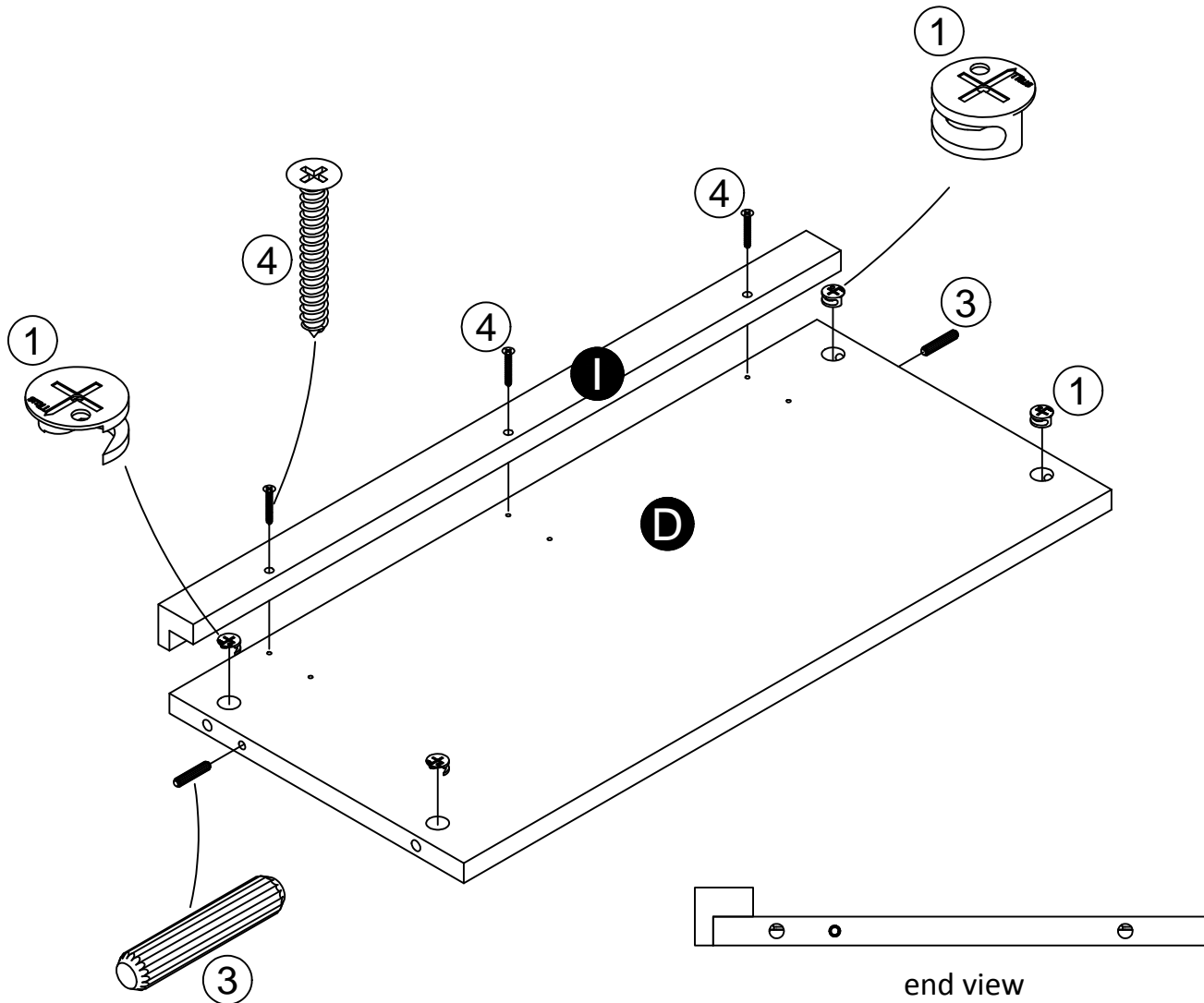
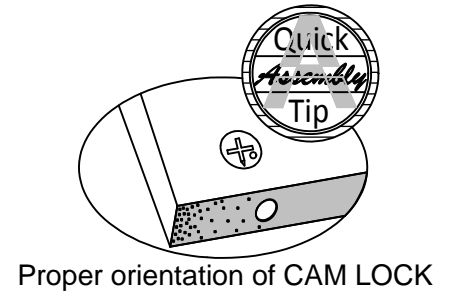
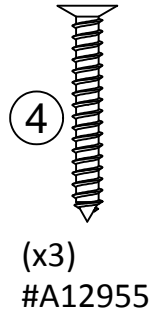
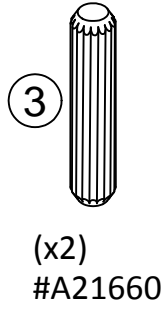
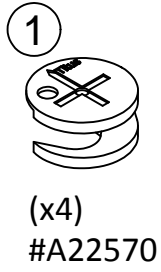
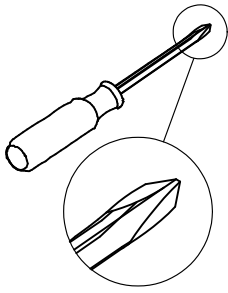

## STEP 5

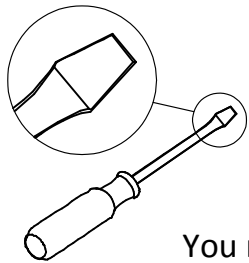

You may need help of another person for this step.

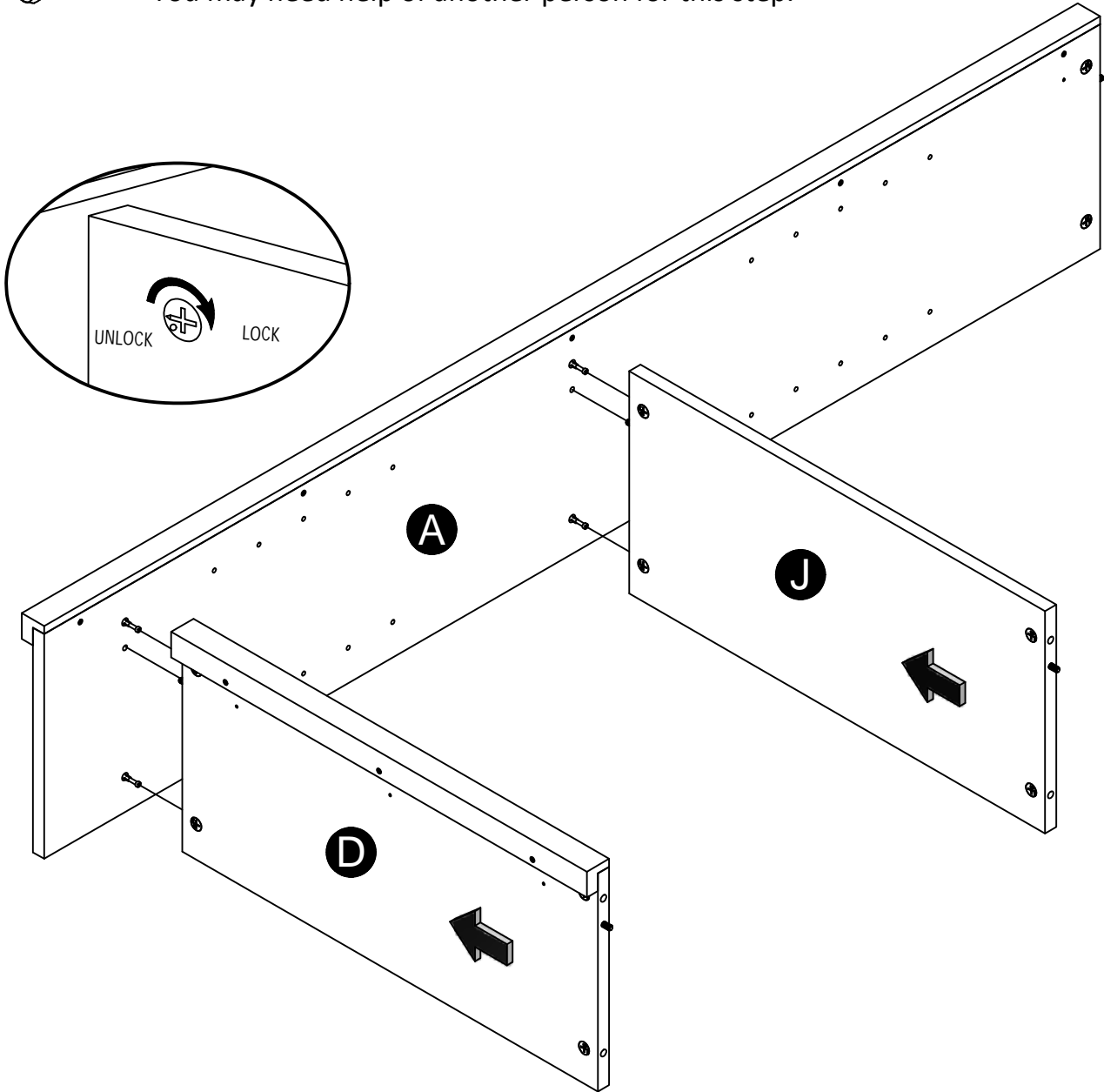

## STEP 6

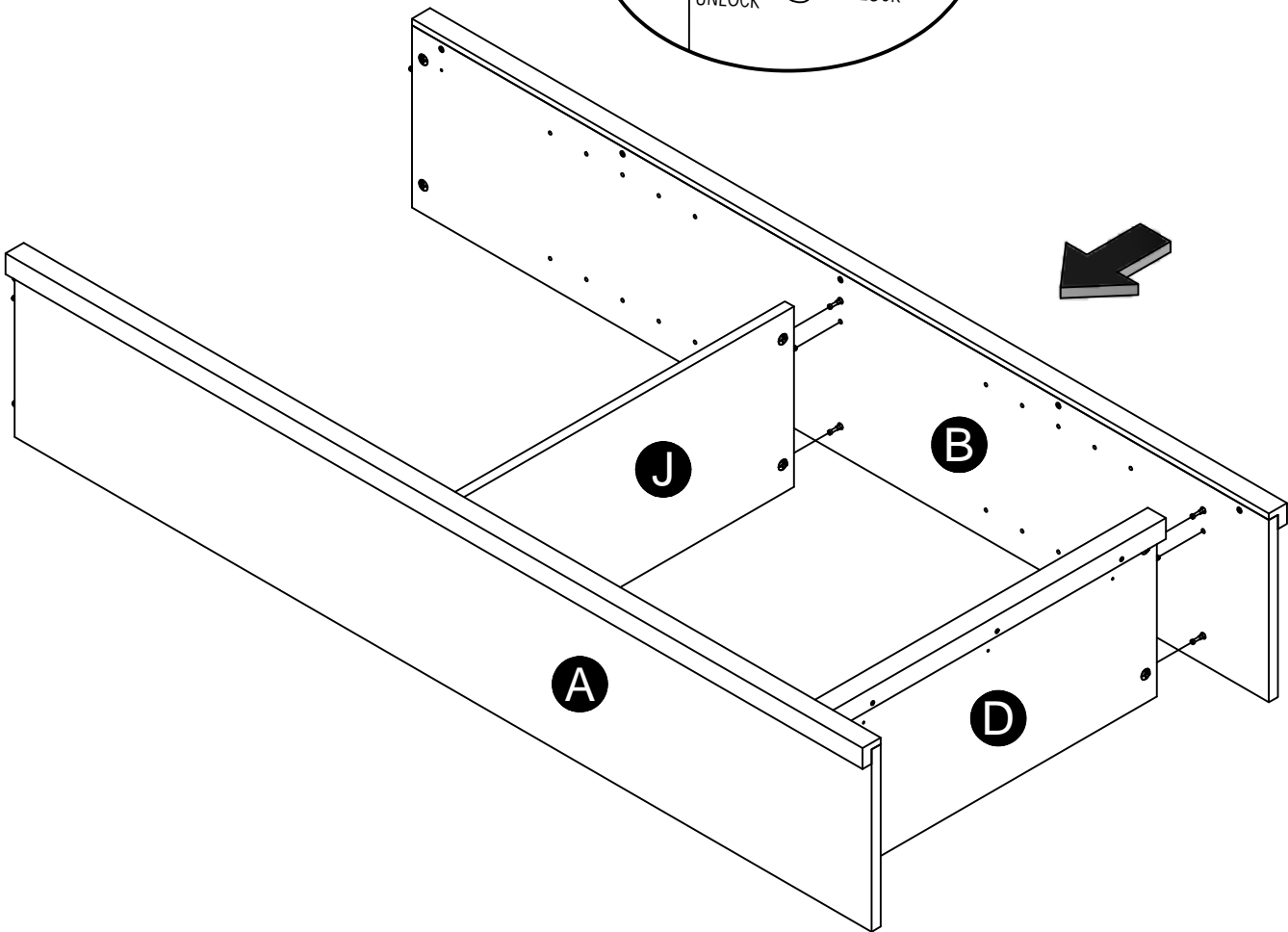
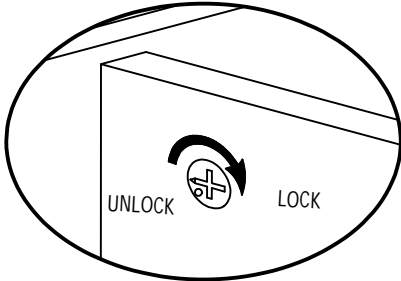
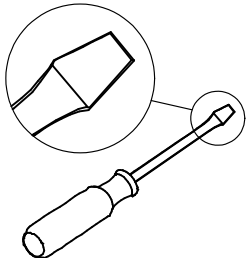

# STEP 7

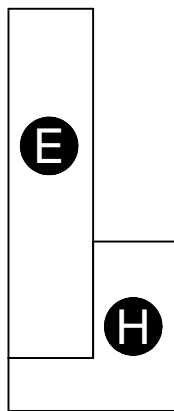
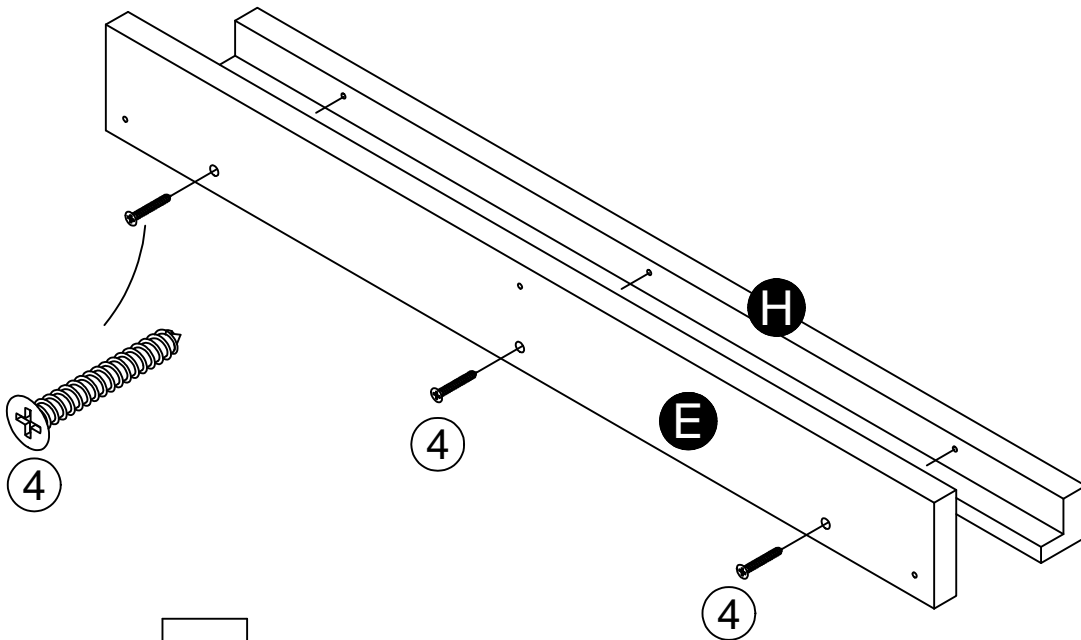
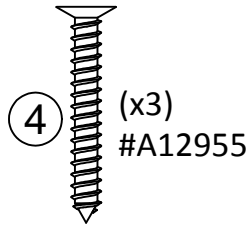
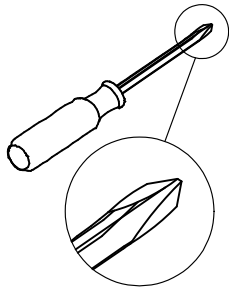

end view

# STEP 8

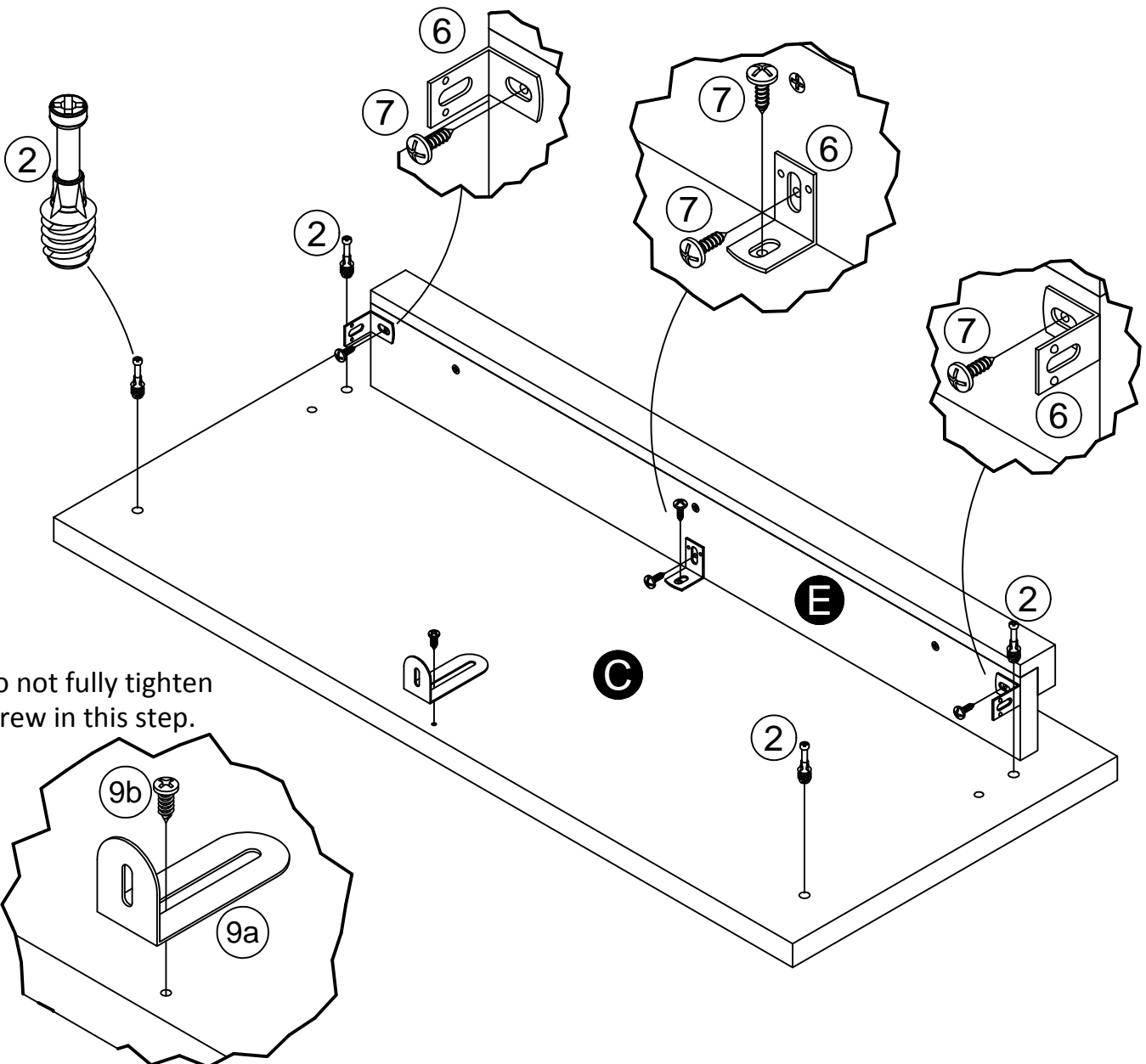
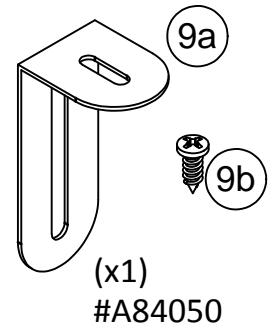
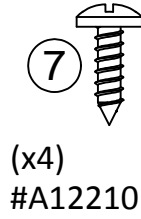
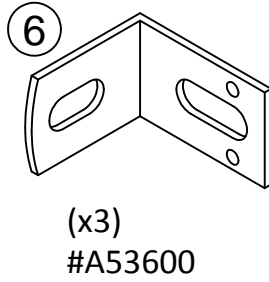
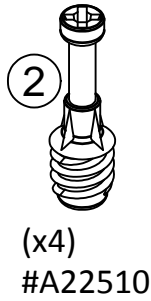
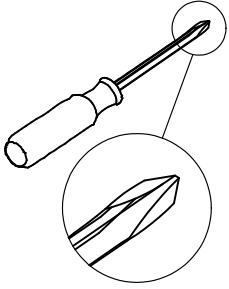

# STEP 9

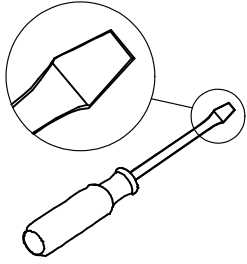

Note: The upper apron (E) and upper molding (H) should fix between the left panel (A) and right panel (B).

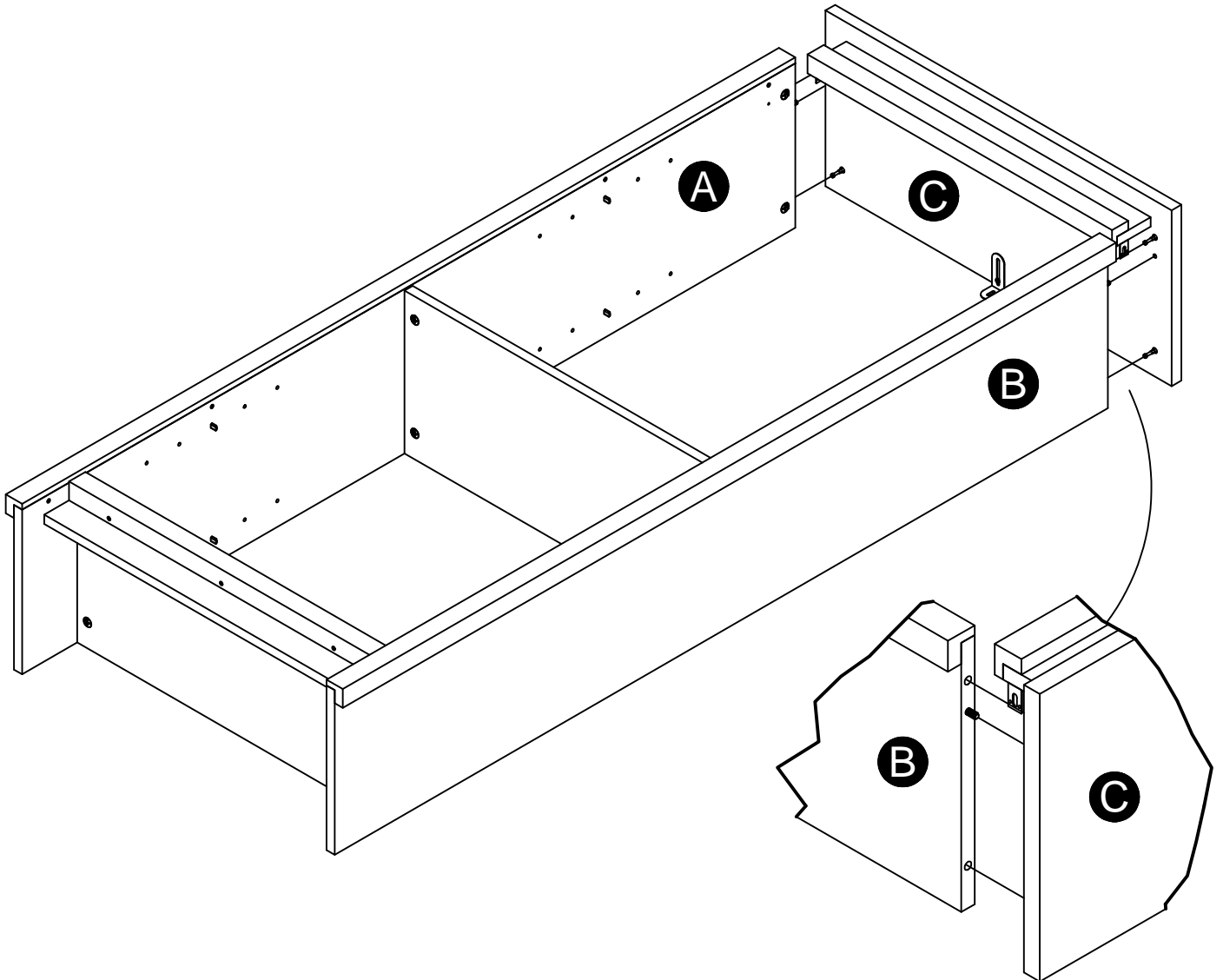
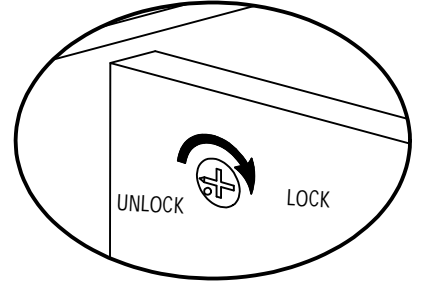

## STEP 10

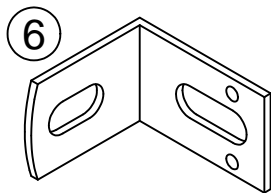
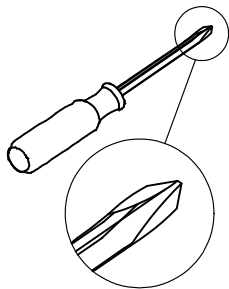

(x3)  
#A53600

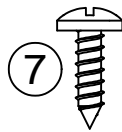

(x8)  
#A12210

With the help of another person, carefully turn the unit onto it's front.  
Attach the lower apron (F) to the bottom using angle brackets (6) and screws (7).

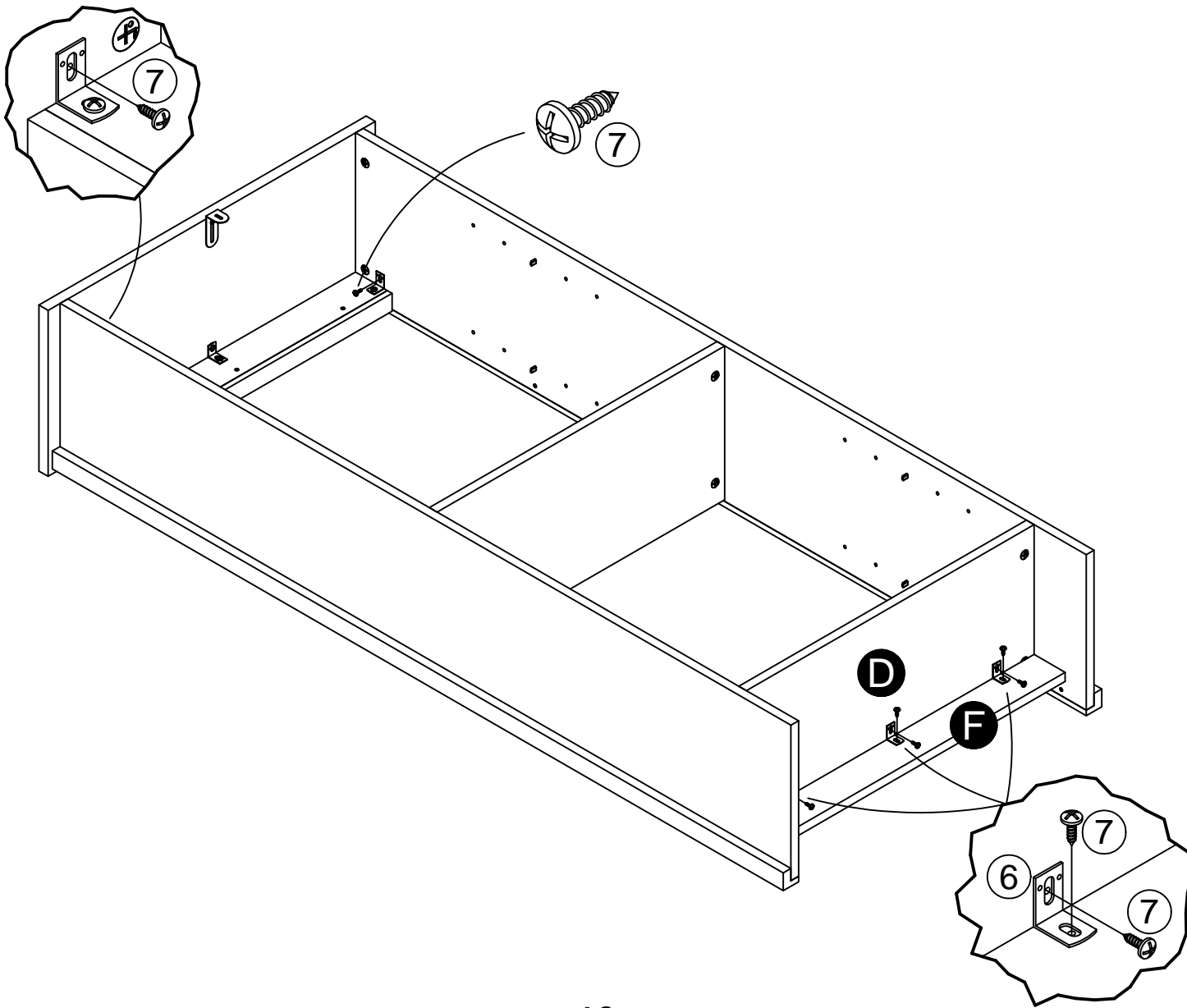



## STEP 11

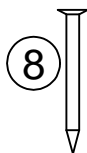
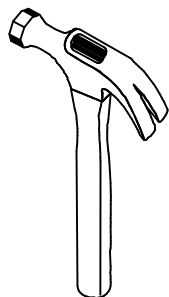

(x36)  
#A21110

### ⚠ WARNING

Please make sure that the Backs are attached securely. All nails must be driven into the parts straight and tightened firmly. Failure to do so could cause instability, product collapse, and/or serious injury.

**IMPORTANT! THE BACK PANEL IS A STRUCTURAL PART OF THIS UNIT AND MUST BE INSTALLED PROPERLY.**

Attach the back panel as shown nailing straight into the raw edges.  
Assure that the unit is square.  
Distance from corner to corner must be equal as shown.

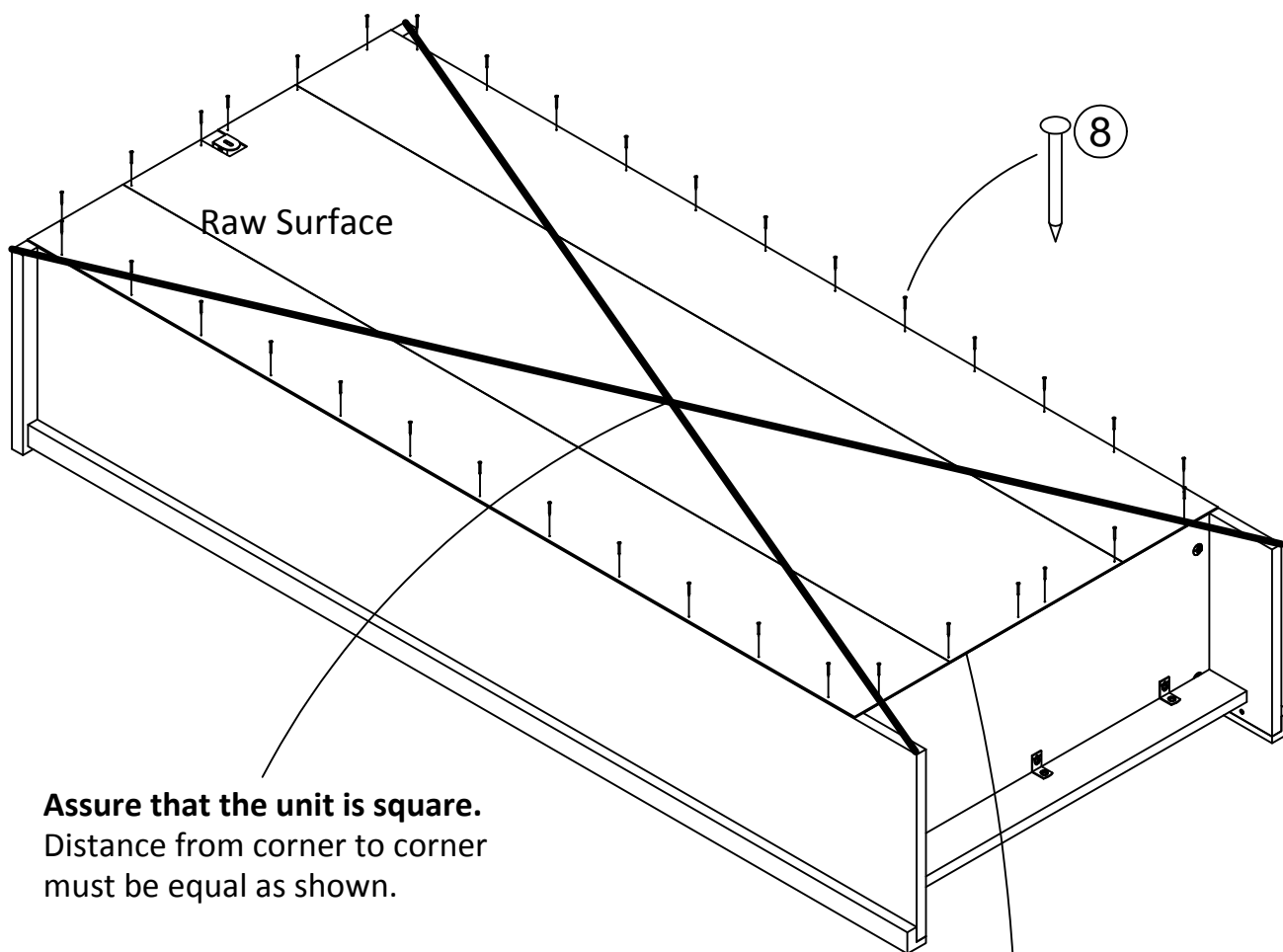

**Assure that the unit is square.**  
Distance from corner to corner must be equal as shown.

Flush edge of back panel with edge of bottom.

## STEP 12

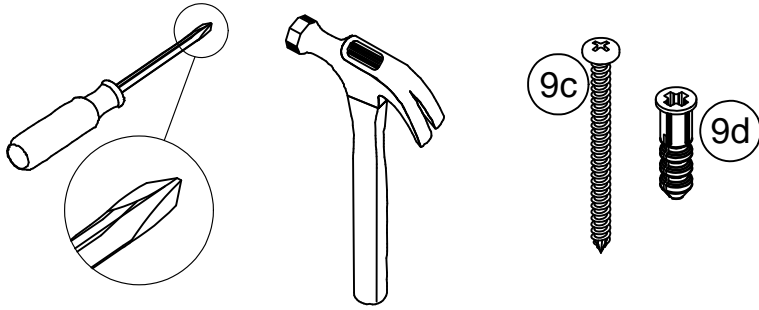

**For Masonry, Concrete, or other wall materials:**

Consult your local hardware store for appropriate anchors to securely attach the safety bracket.

**IMPORTANT:** THIS UNIT MUST BE SECURE TO THE WALL TO HELP PREVENT TIPOVER. FOLLOW THESE INSTRUCTIONS TO INSTALL THE ANTI-TIPPING SAFETY BRACKET PROVIDED WITH THIS PRODUCT.

### WARNING

Serious or fatal crushing injuries can occur from furniture tipover.

**To prevent tipover:**

- \* Install tipover restraint provided
- \* place heaviest items in the lowest drawers
- \* Unless specifically designed to accommodate, do not set TVs or other heavy objects on the top of this product
- \* Never allow children to climb or hang on drawers, door, or shelves
- \* Never open more than one drawer at a time

**Use of tipover restraints may only reduce, but not eliminate the risk of tipover**

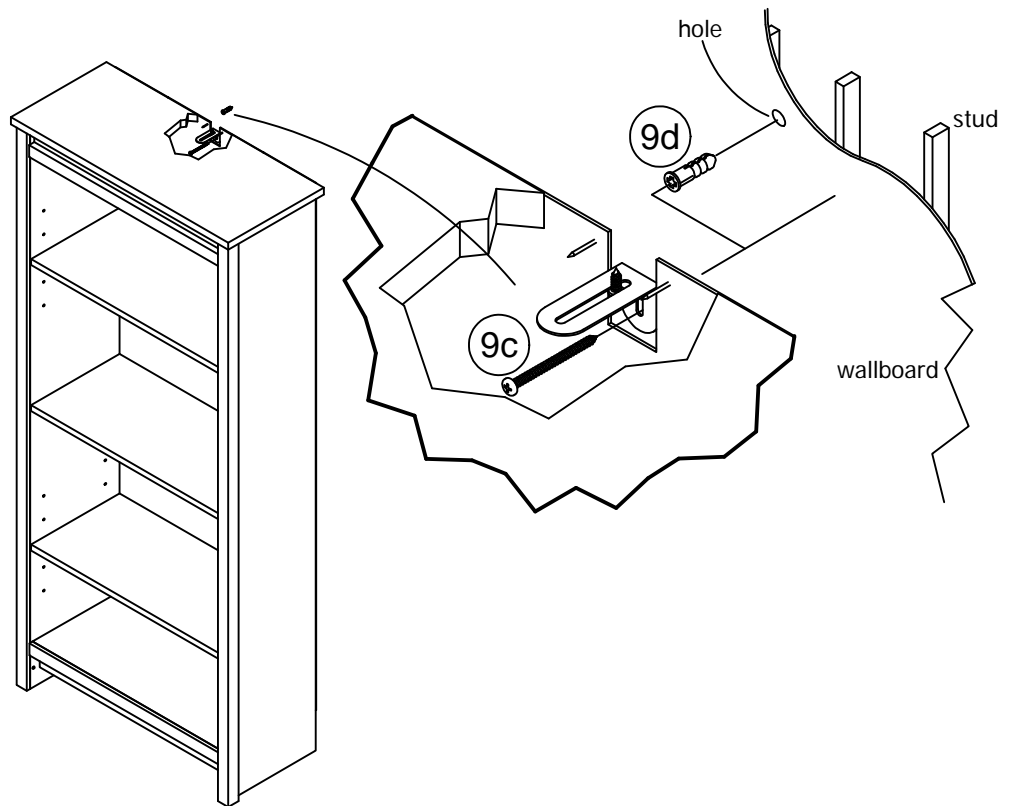

#### OPTION 1: Attachment into a wall stud (preferred method)

Using a stud finder, locate a stud in the wall. Place your unit against the wall, with the safety bracket aligned in this location. To make driving the screw easier, you can drill a 1/8" diameter pilot hole (3mm) through the safety bracket into the stud.

Drive the screw through the safety bracket into the wall stud. Tighten the screw that was not fully tightened in step 8.

#### OPTION 2: Attachment into drywall

Locate your unit where desired against a wall and mark the wall through the safety bracket, then move your unit aside. Drill a 3/16" diameter hole (5mm) into the wallboard. Tap the wall anchor into the hole until it is flush.

Move your unit into location and fasten the wall bracket to the wall anchor with the screw. Tighten the screw that was not fully tightened in step 8.

## STEP 13

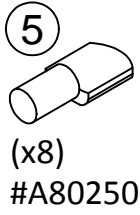

For each adjustable shelf (K), place four shelf supports to your desired height.  
Place the adjustable shelf on the shelf supports.

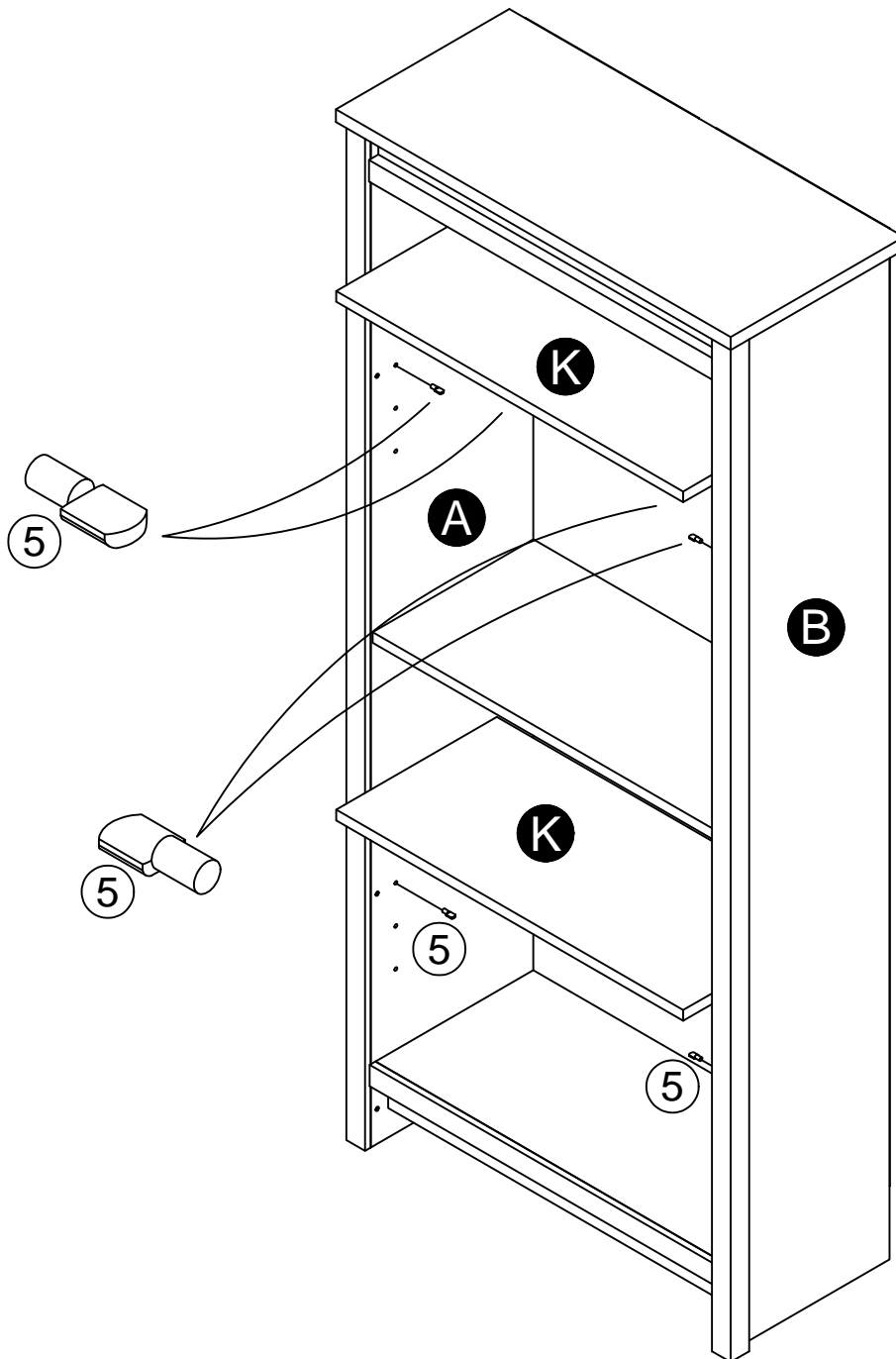

## Maximum Loads

This unit has been designed to support the maximum loads shown. Exceeding these load limits could cause sagging, instability, product collapse, and/or serious injury.

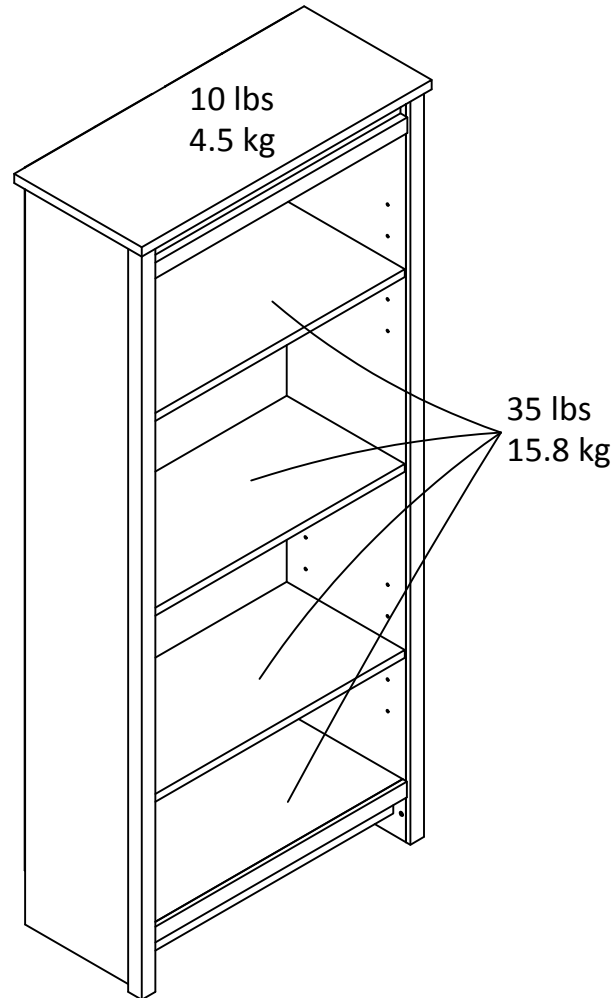

**Warning: Risk of injury to persons - do not place a television on this furniture. This furniture is not approved for use with a television.**

### Certificate of Conformity

1. This certificate applies to the Dorel Home Furnishings, Inc. product identified by this instruction manual.
2. This certificate applies to compliance of this product with the CPSC Ban on Lead-Containing Paint (16 CFR 1303).
3. This product is distributed by: Dorel Home Furnishings, Inc.  
410 East First Street South  
Wright City, MO 63390  
636-745-3351
4. Site of Manufacture: Tiffin OH
5. See front page of instruction manual for date of manufacture.

## Register your product to receive the following:



- \* New trend details - sneak peek on what's new
- \* Surveys - have a voice within our community
- \* Exclusive deals and discount codes
- \* Quick and easy replacement part service

To register your product, visit [ameriwoodhome.com](http://ameriwoodhome.com)

## *5 Star Rating*



Visit your local retailer's website, rate your purchased product and leave us some feedback!

We would like to extend a big "Thank You" to all of our customers for taking the time to assemble this Ameriwood Home product, and to give us your valuable feedback.

*Thank  
You!*

## Cubierta Delantera

Este libro de instrucciones contiene información **IMPORTANTE** de seguridad. Por favor lea y manténgalo para referencia en el futuro.

**No Regrese este producto!** Comuníquese con nuestro amistoso equipo de servicio al cliente para obtener ayuda.

Llámenos al: 1-800-489-3351 (Gratis) Lunes - Viernes 9am - 5pm CST

Visitar: [www.ameriwoodhome.com](http://www.ameriwoodhome.com)

## PRECAUCION

Este mueble puede volcarse y causar graves heridas y/o muerte.

Anclar el mueble a un poste de madera en la pared (si esto se requiere).

No Permita que los niños monten el mueble.

Mantenga los artículos más pesados en los cajones de abajo.

## Consejos Útiles (página 2)

- Abra su artículo en el área donde usted planea utilizarlo para evitar levantar y moverlo menos
- Identificar, ordenar y contar las piezas antes de intentar ensamblar
- Las clavijas de compresión se golpean con un martillo
- Las diapositivas están marcadas con una R (derecha) y L (izquierda) para la colocación correcta
- Asegúrese de que siempre este el punto localizado en la parte superior de bloqueador de leva este volteado hacia borde exterior
- Utilizar todos los clavos para el panel de atrás y distribuirlos por igual
- El panel de atrás debe utilizarse para asegurarse de que la unidad quede fija y firme
- No use químicas fuertes ni limpiadores abrasivos en este artículo
- Nunca empuje, tire ni arrastre los muebles

## Antes de Que Empieces (página 3)

- Lea cuidadosamente cada paso y siga el orden correcto
- Separar y contar todas sus piezas y hardware
- Dése suficiente espacio para el proceso de ensamble
- Tenga las siguientes herramientas: destornillador de cabeza plana, #2 cabeza Phillips  
Destornillador y martillo
- Precaución: Si usa un taladro electrónico o un destornillador eléctrico para atornillar, por favor asegúrese que deje de atornillar cuando el tornillo este apretado. Fallar hacer esto puede causar barrer el tornillo.

## Sistema de fijar el bloqueo de leva (página 3)

Esta sistema de fijar el bloqueo de leva sera usado en todo el proceso ensamble.

## **Página 11**

Es probable que requiera de la ayuda de otra persona para este paso.

## **Página 14**

No apriete totalmente el tornillo en este paso.

## **Página 15**

Nota: La plataforma superior (E) y la moldura superior (H) deben fijarse entre el panel izquierdo (A) y el panel derecho (B).

## **Página 16**

Con la ayuda de otra persona, gire cuidadosamente la unidad hacia el frente.

Fije la plataforma inferior (F) a la parte inferior con los soportes angulares (6) y los tornillos (7).

## **Página 17**

Conecte los panel trasero como se muestra clavando directamente en los bordes sin procesar.

Asegura que e; inidad es cuadrada.

Distancia de esquina a esquina debe ser igual como se muestra por favor.

**IMPORTANT:** El Panel trasero es una parte estructural de la unidad y debe ser instalado correctamente.

## **Página 19**

Para cada estante ajustable (K), coloque los cuatro soportes del estante a la altura que desee.

Coloque el estante ajustable sobre los soportes de estantes.

## **Página 20**

### **CARGA MAXIMA**

Esta unidad ha sido diseñada para soportar la carga máxima anotada. El exceder estos límites puede causar inestabilidad, colapsarse y/o causar serias lesiones.

**ADVERTENCIA:** Riesgo de lesiones a las personas - no coloque un televisor sobre muebles. Este mueble no está aprobado para su uso con un televisor.

## STEP 12

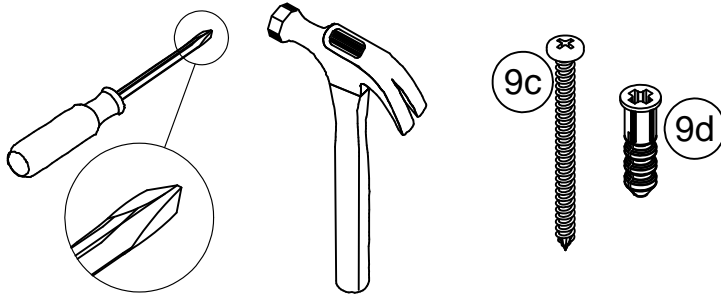

**Para mampostería, hormigón u otros materiales de la pared:**

Consulte a su ferretería local para los anclajes apropiados para fijar firmemente el soporte de seguridad.

**IMPORTANTE:** ESTA UNIDAD DEBE SER ASEGURADA CON LA PARED PARA PREVENIR VOLQUEO. SIGA ESTAS INSTRUCCIONES PARA INSTALAR EL SOPORTE DE SEGURIDAD ANTIVOLQUEO SUMINISTRADO CON ESTE PRODUCTO.

### ADVERTENCIA

Graves lesiones pueden ocurrir, como aplastamiento u muerte por causa de volqueo del mueble:

- Instale el equipo de seguridad de antivolqueo
- Coloque los artículos más pesados en los cajones mas bajos
- Al menos que específicamente diseñado para acomodar, **no** establezca televisores u otros objetos pesados encima de este producto.
- No permita que los niños se suban o se cuelguen de los cajones, puertas, o estantes
- No abra más de un cajón a la vez

**El uso del equipo de seguridad de antivolqueo reduce, pero no elimina el riesgo de volqueo.**

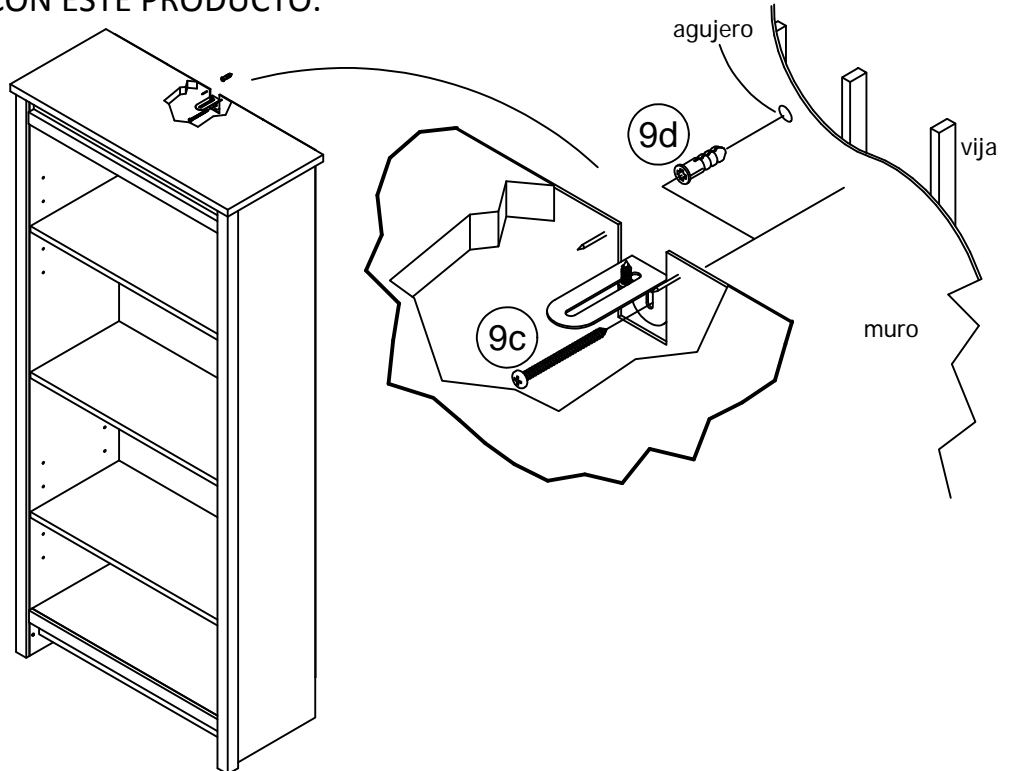

**OPCION 1:** Para asegurar en una viga de la pared (método preferido).

Use un detector de vigas, localice la viga en la pared. Coloque la unidad contra la pared y alinee con el soporte de seguridad en esta ubicación. Para hacer este proceso más fácil, se puede perforar un agujero piloto de 1/8" de diámetro (3mm) a través del soporte de seguridad hacia la viga en la pared. Atornille el tornillo a través del soporte de seguridad y hacia la viga en la pared. Apriete el tornillo que no fue totalmente ajustado en el paso 8.

**OPCION 2:** Para asegurar en paredes de yeso

Localizar su unidad en la posición deseada contra una pared y marque la pared a través del soporte de seguridad, a continuación, mueva a un lado la unidad. Perforar un agujero de 3/16" de diámetro (5mm) en el panel de yeso. Mueva la unidad a su lugar y empareje el soporte de seguridad al agujero en la pared, atornille el tornillo para que la unidad quede fija y segura. Apriete el tornillo que no fue totalmente ajustado en el paso 8.



## Página 21

Registre su producto para recibir lo siguiente:

- \* Detalles de nuevas tendencias - Vistazo a lo nuevo
- \* Encuestas - alee su voz entre su comunidad
- \* Códigos de ofertas y descuentos exclusivos
- \* Fácil y rápido servicio de partes de remplace

Para registrar su producto, visite [ameriwoodhome.com](http://ameriwoodhome.com)

Clasificación de 5 estrellas

Visite el sitio web de su tienda local, califique su comprado y denos sus comentarios!

Nos gustaría enviar un gran "Agradecimiento" a todos nuestros clientes por tomarse el tiempo de ensamblar este producto de Ameriwood Home, y por darnos sus valiosos comentarios.

Gracias

## Couverture Avant

CE LIVRET D'INSTRUCTION CONTIENT DES INFORMATIONS **IMPORTANTES** SUR LA SÉCURITÉ. VEUILLEZ LIRE ET GARDER POUR UNE RÉFÉRENCE FUTURE

**Ne retournez pas ce produit!** Contactez notre équipe de service à la clientèle amicale d'abord pour obtenir de l'aide.

**Appelez-nous:** 1-800-489-3351 (sans frais) du Lundi au Vendredi de 9h à 17h Heure Centrale

**Visitez:** [www.ameriwoodhome.com](http://www.ameriwoodhome.com)

## ATTENTION

Le meuble peut basculer et causer des blessures graves ou la mort.

Ancrer le meuble à une planche murale dans le mur (si indiqué).

Ne laissez pas les enfants grimper sur le meuble.

Placez les articles lourds sur les étagères ou dans les tiroirs inférieurs.

## Astuces Utiles (page 2)

-Ouvrez votre article dans la zone que vous prévoyez de le garder pour moins de levage lourd

-Identifier, trier et compter les pièces avant d'essayer d'assembler

-Les goujons de compression sont taraudés avec un Marteau

-Les glissières sont marquées d'un R (droit) et d'un L (gauche) pour un bon placement

-Assurez-vous toujours de faire face la pointe situé sur le haut de la Serrure de Came vers le bord extérieur

-Utiliser tous les clous fournis pour le panneau arrière et les répartir également

-Le panneau arrière doit être utilisé pour vous assurer que votre appareil est robuste

-N'utilisez pas de produits chimiques agressifs ou de nettoyeurs abrasifs sur cet appareil

-Ne jamais pousser, tirer, ou faire glisser votre meuble

## Avant de Commencer (page 3)

-Lisez attentivement chaque étape et suivez le bon ordre

-Séparez et comptez toutes vos pièces et matériaux

-Donnez-vous suffisamment de place pour l'assemblage

-Avoir les outils suivants: tournevis à tête plate, #2 tournevis Phillips, et Marteau

-Attention: Si vous utilisez une perceuse électrique ou un tournevis électrique pour visser, veillez à ralentir et arrêter lorsque la vis est bien serrée. Le non-respect de cette consigne peut endommager la vis.

## Système de Fixation de Came (page 3)

Ce Système de Fixation de Came sera utilisé tout au long de l'assemblage

## Page 11

Vous aurez peut-être besoin de l'aide d'une autre personne pour cette étape.

## Page 14

Ne serrez pas complètement la vis dans cette étape.

## Page 15

Remarque : La ceinture supérieure (E) et la moulure supérieure (H) doivent être fixés entre le panneau de gauche (A) et le panneau de droite (B).

## Page 16

Avec l'aide d'une autre personne, tournez soigneusement l'unité sur son front.  
Attachez la ceinture inférieure (F) à l'aide des équerres (6) et des vis (7).

## Page 17

Attachez les panneaux arrière comme indiqué en cliquant directement dans les bords bruts.  
Assurez-vous que le meuble est à égalité.

La distance de coin doit être égale comme montré.

**IMPORTANT:** Le panneau arrière est une partie structurelle de cet appareil et doit être installé correctement.

## Page 19

Pour chaque étagère réglable (K), placez quatre supports d'étagère à la hauteur désirée.  
Placez l'étagère réglable sur les supports d'étagère.

## Page 20

### CHARGES MAXIMALES

Ce meuble a été conçu pour supporter les charges maximales indiquées. En excédant ces limites de charge, le meuble pourrait devenir instable, s'effondrer, et/ou causer des blessures graves.

**AVERTISSEMENT :** Risque de blessure corporelle - ne pas placer une télévision sur ce meuble. Ce meuble n'est pas approuvé pour une utilisation avec une télévision.

## STEP 12

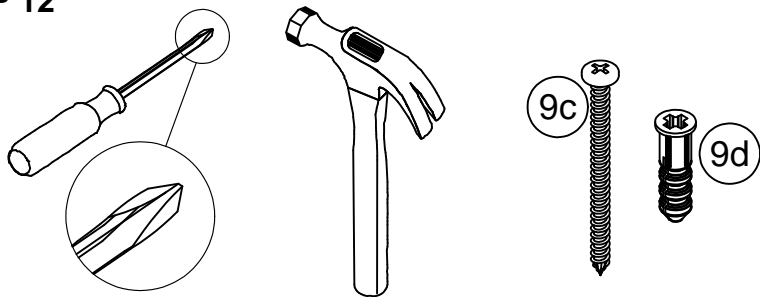

**Pour la maçonnerie, béton ou d'autres matériaux de mur:**

Consultez votre magasin local de matériel pour les ancrages appropriés pour fixer le support de sécurité.

**IMPORTANT:** CET APPAREIL DOIT ÊTRE FIXÉ AU MUR POUR AIDER À PRÉVENIR LE BASCULEMENT. SUIVRE CES INSTRUCTIONS POUR INSTALLER LE SUPPORT DE SÉCURITÉ ANTI-BASCULEMENT FOURNI AVEC CE PRODUIT.

### ATTENTION

**Blessures par écrasement graves ou mortelles peuvent se produire par le renversement des meubles. Pour éviter tout renversement:**

- \* Installer la retenue de renversement fourni
- \* Placez des objets les plus lourds dans les tiroirs les plus bas
- \* Sauf spécifiquement conçu pour accueillir, ne placez pas les téléviseurs ou d'autres objets lourds sur le dessus de ce produit
- \* Ne jamais laisser les enfants grimper ou se pendre sur les tiroirs, portes, ou étagères

\* Ne jamais ouvrir plus d'un tiroir à la fois  
**Utilisation de support de sécurité ne peut réduire, mais pas éliminer le risque de renversement.**

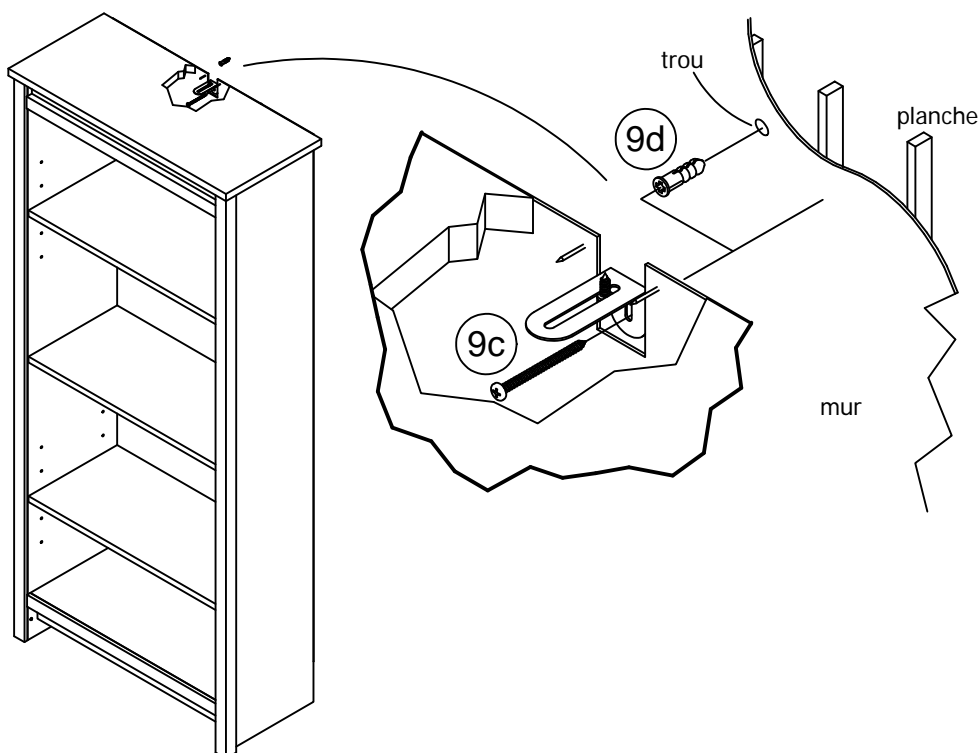

### OPTION 1: Fixation sur un montant mural (méthode préférée)

En utilisant un détecteur de montants, localisez une planche dans le mur. Placez votre appareil contre le mur, avec le support de sécurité aligné à cet endroit. Pour rendre la conduite de la vis plus facile, vous pouvez percer un trou pilote de 1/8" de diamètre (3 mm) à travers le support de sécurité dans la planche. Conduisez la vis à travers le support de sécurité dans le montant du mur. Serrer la vis qui n'a pas été entièrement serré à l'étape 8.

### OPTION 2: Fixation dans une planche sèche

Localisez votre meuble où désiré contre un mur et marquer le mur à travers le support de sécurité, puis déplacez votre meuble de côté.

Percez un trou de 3/16" de diamètre (5 mm) dans le mur. Enfoncez l'ancrage mural dans le trou jusqu'à ce qu'il soit égal. Déplacez votre meuble dans l'emplacement et fixez le support mural à l'ancrage mural avec la vis. Serrer la vis qui n'a pas été complètement serré à l'étape 8.

## Page 21

Enregistrez votre produit pour recevoir les éléments suivantes:

- \* Détails sur les nouvelles tendances - un aperçu sur les nouveautés
- \* Sondages - avoir une voix au sein de notre communauté
- \* Offres exclusives et codes promo
- \* Service de pièces de rechange rapide et facile

Pour enregistrer votre produit, visitez [ameriwoodhome.com](http://ameriwoodhome.com)

5 Étoiles

Visitez le site Web de votre détaillant local, évaluez votre produit acheté et laissez-nous quelques commentaires !

Nous tenons à offrir un grand "Merci" à tous nos clients pour avoir pris le temps d'assembler ce produit "Ameriwood Home", et de nous donner vos commentaires précieux.

Merci