



## **Assembly Instructions Model 51533**

### ***Mid-Size Two Door Cart with Drop Leaf***



#### **GENERAL:**

1. You have purchased model 51533.
2. Should you need assistance or need to replace a damaged or missing part simply give us a call M-F at 607-652-7321 from 7:30 am - 4:30 pm EST and we'll send you the prepaid part via UPS usually that same day! You may also email us [info@catskillcraftsmen.com](mailto:info@catskillcraftsmen.com).
3. Read the assembly instructions and the enclosed brochure before beginning assembly. Assembly is easy if you read and follow the instructions step by step. See our website, [www.catskillcraftsmen.com](http://www.catskillcraftsmen.com) for assembly tips and videos.
4. The only tools needed are a hammer, a small and a medium Phillips head screwdriver and a medium flat blade screwdriver. A pencil is also needed. A power screwdriver will speed assembly, but is not required. Place a few drops of vegetable oil on the threads of wood screws before screwing into the solid hardwood parts.
5. Glides are sometimes pre-packed with screws. These are not used.

# CABINET PARTS 51533

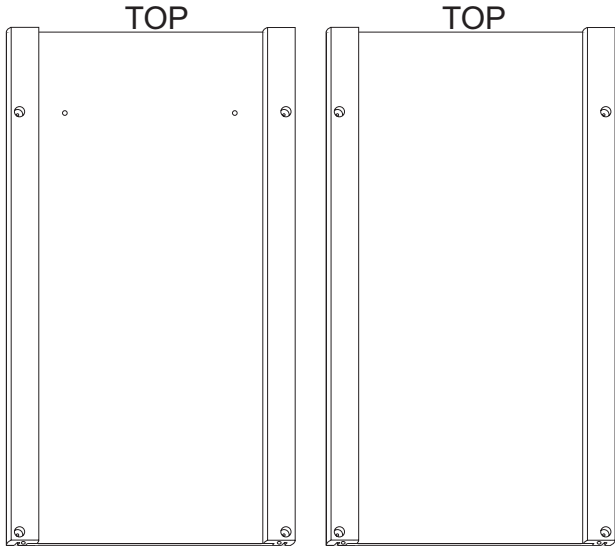

Handle Side Panel (1)  
P/N:SP/HDL-51533

Plain Side Panel (1)  
P/N:SP/PL-51533

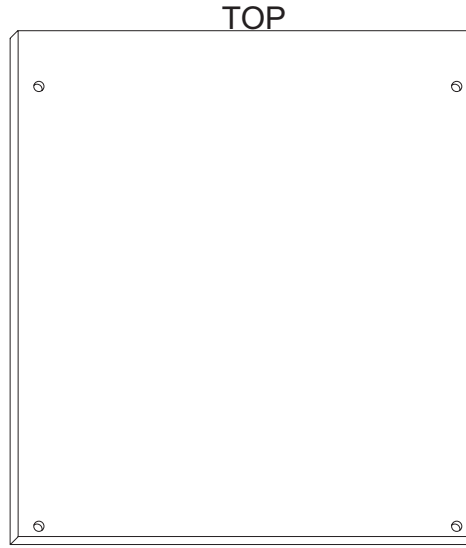

Back Panel (1)  
P/N:BP-51533

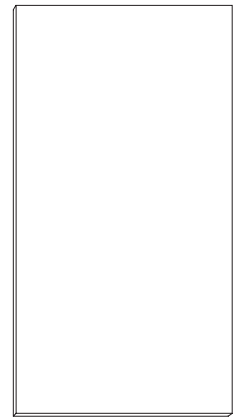

Drawer Bottom (1)  
P/N:DBOT-51533

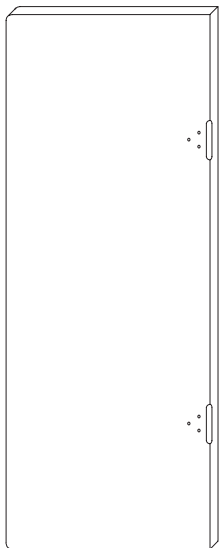

Drop Leaf (1)  
P/N:DL-51533

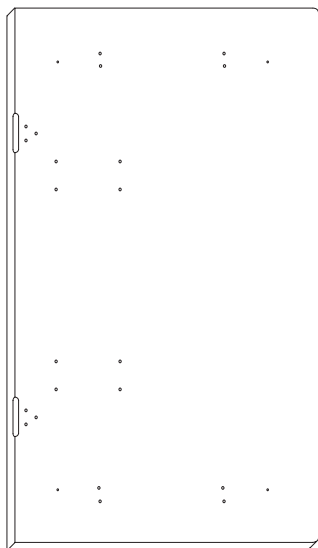
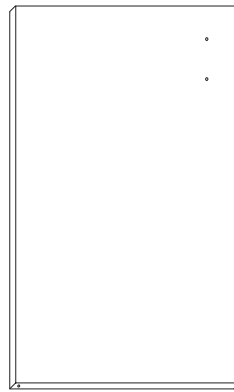
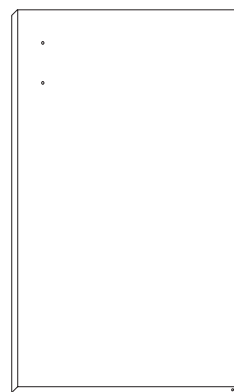

Table Top (1)  
P/N:TT-51533



Left Door (1)  
P/N:DOR-51533/L



Right Door (1)  
P/N:DOR-51533/R

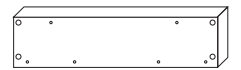

Glide Support Sticks (2)  
P/N: GLD SUP - 51533

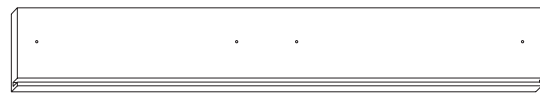

Drawer Front (1)  
P/N:DF-51533

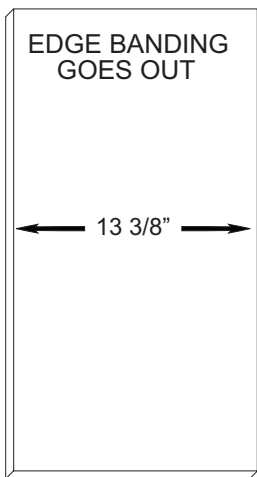

Middle Shelf (1)  
P/N:MS-51533

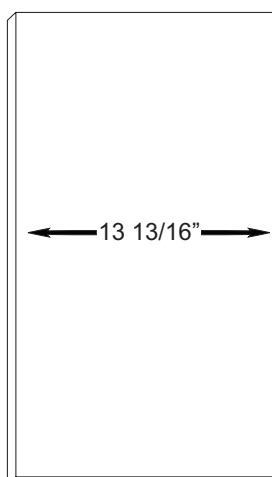

Bottom Shelf (1)  
P/N:BS-51533



Drawer Side Left (1)  
P/N:DS-51533/L

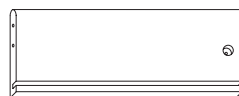

Drawer Side Right (1)  
P/N:DS-51533/R



Door Spacer (1)  
P/N:DORS-51533

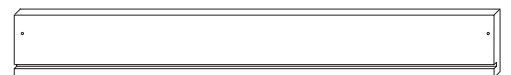

Drawer Back (1)  
P/N:DBK-51533



Bottom Brace (1)  
P/N:B-51533 BF



Top Brace (1)  
P/N:B-17 1/2-TF-51533

# HARDWARE 51533



1 3/4" Phillips Flat Head Bolt (8)



(Used to attach drawer back)

1 1/2" Phillips Flat Head #8 Screw (2)



(Used to attach drawer front)

Cam Posts (2)



(Used to attach glide supports)

1 1/4" Phillips Flat Head #8 Screw (8)



(Used to attach towel bar)

1" Phillips Flat Head #8 Screw (2)



(Used to attach door handles)

7/8" Truss Head Machine Screw (6)

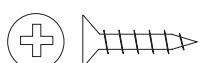

(Used to attach cabinet glides & "L" brackets)

5/8" Phillips Flat Head #7 Screw (12)



(Used on door spacer & drop leaf hardware)

5/8" Phillips Flat Head #8 Screw (23)



(Used on Drawer Glides)

5/8" Phillips Flat Head #5 Screw (4)



(Brace Pin)

3/4" Long 3/16" DIA. Steel Pin (4)

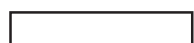

(Shelf Pin)

1" Long 3/16" DIA. Steel Pin (8)

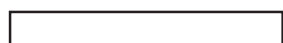

(Door Pin)

1 1/2" Long 3/16" DIA. Steel Pin (4)

## MAGNET PACK

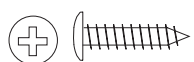

5/8" #6 Pan Head Screw (2)



1/2" Phillips Flat Head #4 Screw (1)



Magnet (1)



Magnet Plate (1)

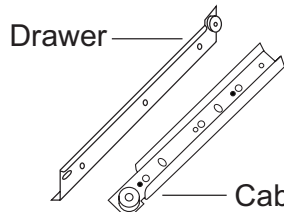

Drawer

Cabinet

Drawer Glide (1 Set)

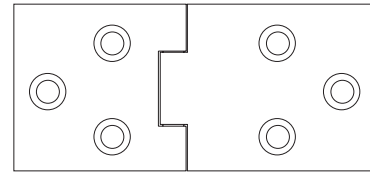

Hinge (2)

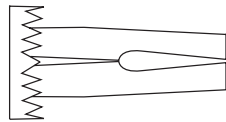

Caster Socket (4)

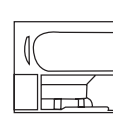

Cam (2)

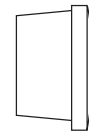

5/8 Wooden Disk (8)

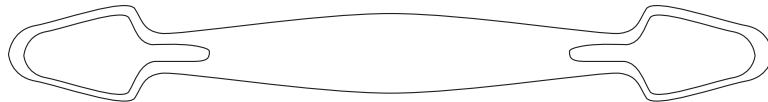

Nickel Handle (3)



Towel Bar Post (2)

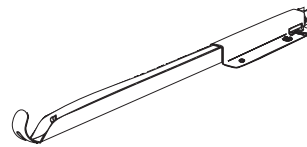

Drop Leaf Support (2)

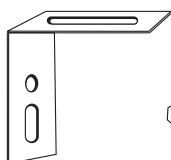

L-Bracket (4)



3/16" Flat Washer (4)



10-24 Hex Nut (8)

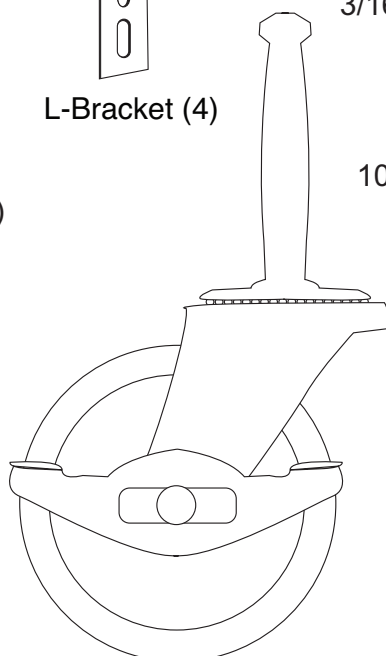

Locking Wheel Caster (2)

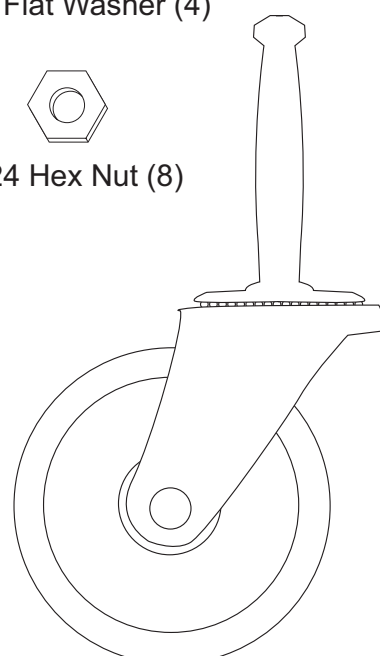

Non-Locking Wheel Caster (2)

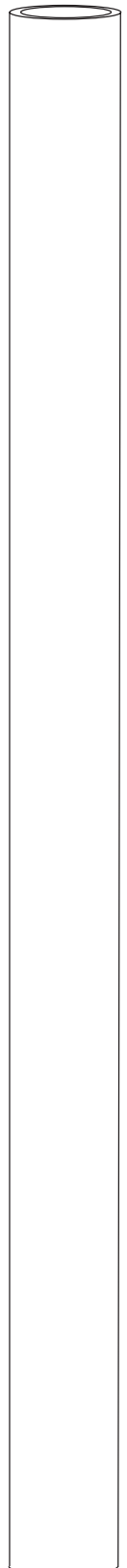

Polished Nickel Towel Bar (1)

## STEP 1

A. Decide which side to put the towel bar on. Attach a Glide Support Stick to the top of each Side Panel using 1 1/4" #8 screws. The countersunk holes (reamed out) in the stick are positioned as in illustration 1 so that the glide holes are toward the lower edge. Sticks should be flush with top of panel.

B. Attach the cabinet glide of the Drawer Glides to the Glide Support Stick using 5/8" #7 flat head screws. Left glide to left Side Panel, right glide to right Side Panel. The glides look almost alike however, the right glide (as you face the cart) has a rolled lip at the top of the glide that keeps the drawer glide wheel in place. Line up the holes in the glides so that the end with the wheel comes flush with the front edge of the Table Top Stick.

C. Attach the "L" brackets to the top of the glide supports using 5/8" #7 screws. Use the slot, the side with the hole is used to attach the table top. The top of the "L" Bracket should be even with the top edge of the glide support stick.

Note: Glides are marked right/left with imprint behind wheel.

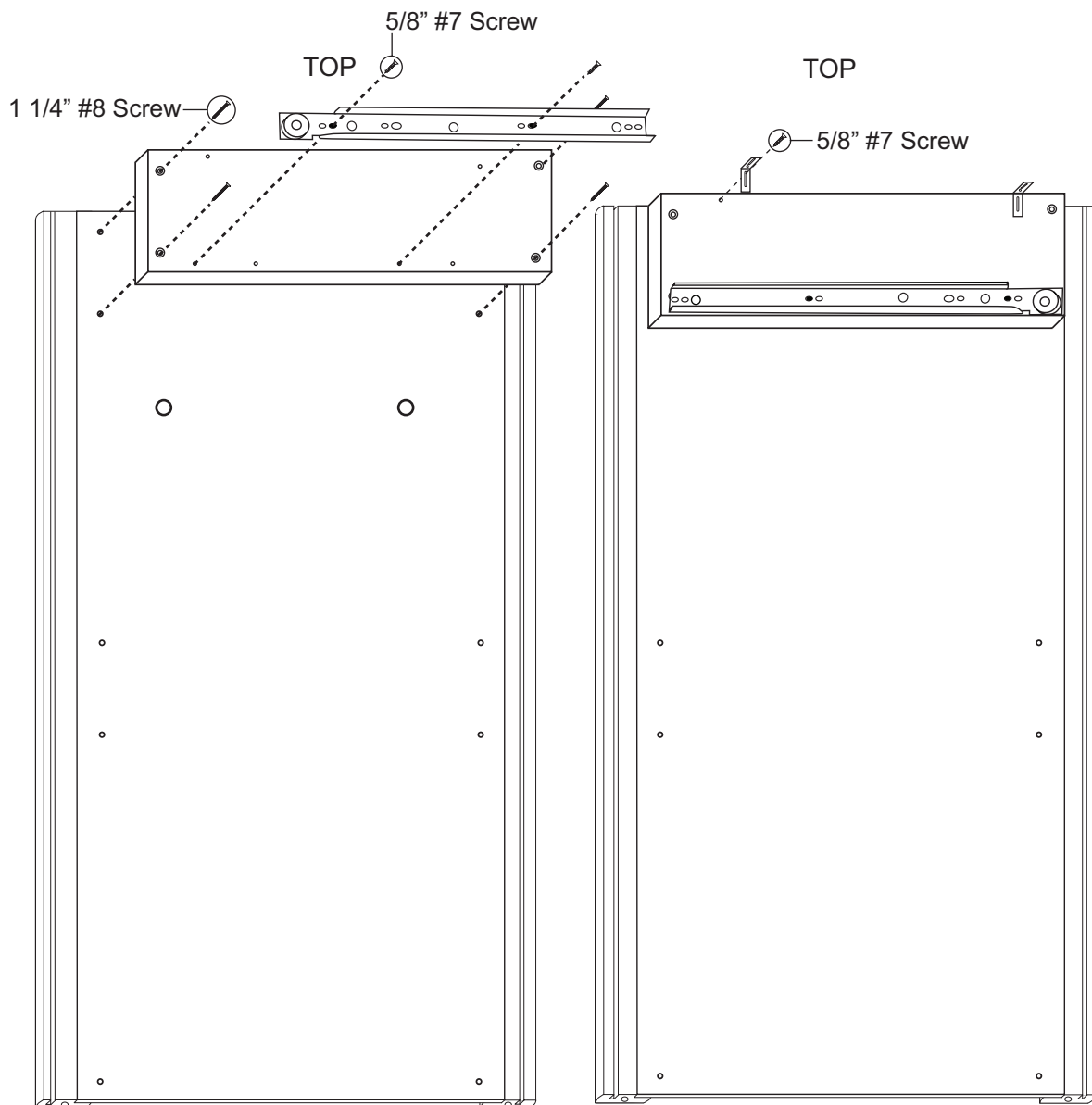

## STEP 2

A. Lay back panel flat on a smooth surface with holes up.

B. Attach both side panels (glide wheels go toward front of cart) with 1 3/4" bolts and hex nuts. After inserting bolts through the holes in the side panels, through the holes in the long edges of the back panel, place a hex nut on the tip of your finger, align nut with bolt and tighten.

C. Look ahead to step 5 which shows side panels attached to back panel. Glide wheels toward the front.

Note: Make sure you position the side panels according to drawer side left or right.

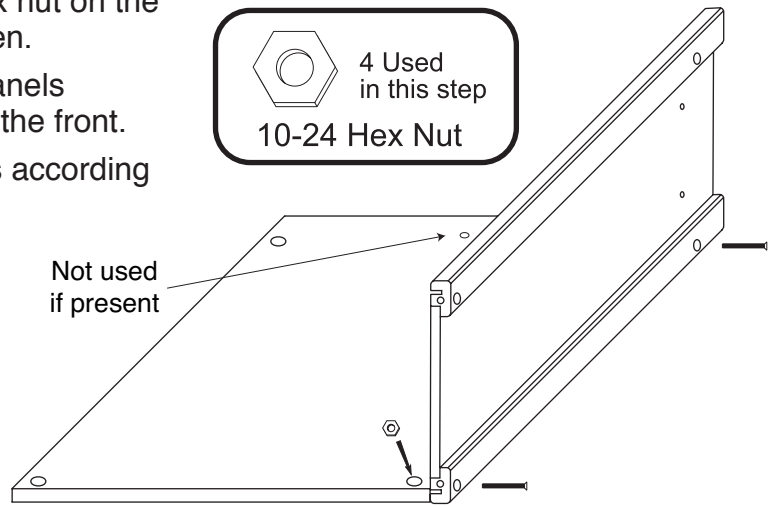
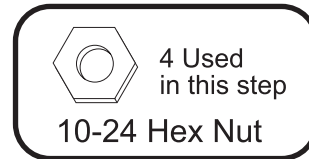
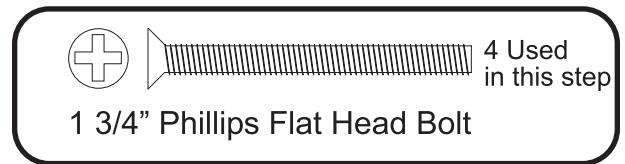
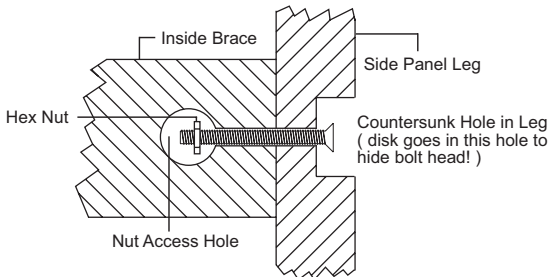

## STEP 3

STEPS 3-13 WILL BE ACCOMPLISHED WITH THE UNIT TOP UPSIDE DOWN (INVERTED), BUILDING UPWARD TOWARD THE BOTTOM/CASTER END! BE CAREFUL AS PART DESCRIPTIONS ARE BASED ON AN UPRIGHT, COMPLETED UNIT!

Assemble top by placing the top and the drop leaf upside down on a smooth flat surface.

Install hinges using 5/8 #8 screws. The longer part of the hinge goes on the drop leaf with the short part on the cart top. Fasten the drop leaf supports using 5/8 #8 screws.

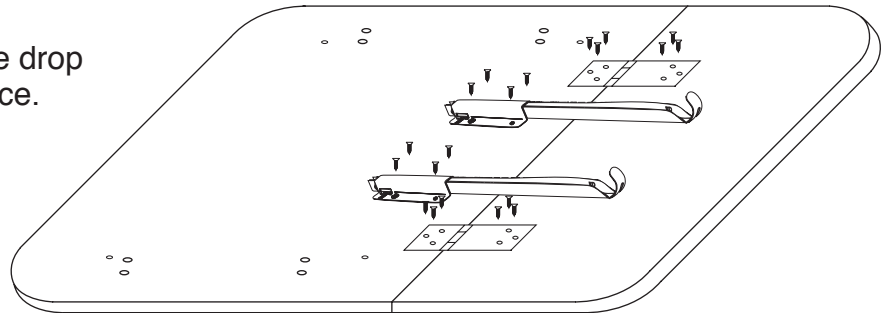

## STEP 4

Make a large X mark over each of the inside pilot holes in the bottom. Make marks about 1 1/2" long. These marks will help you align the cabinet with the inside pilot holes in step 5.

This table top is used on two different models. The holes on the outside, without markings in the illustration, are not used.

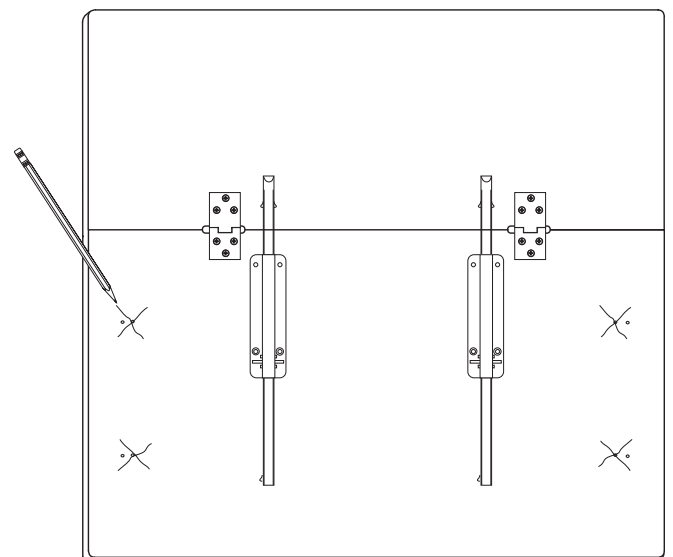

## STEP 5

A. Turn the side/back assembly upside down (invert) on top of the inverted table top.

B. Using the X marks as a guide, insert the tips of the 5/8" #7 screws into the pilot holes through "L" bracket hole in the unit top and finger tighten. When all 4 screws are properly aligned, tighten down.

D. Tap two 1" pins into EACH side panel. These pins will hold the bottom shelf as illustrated.

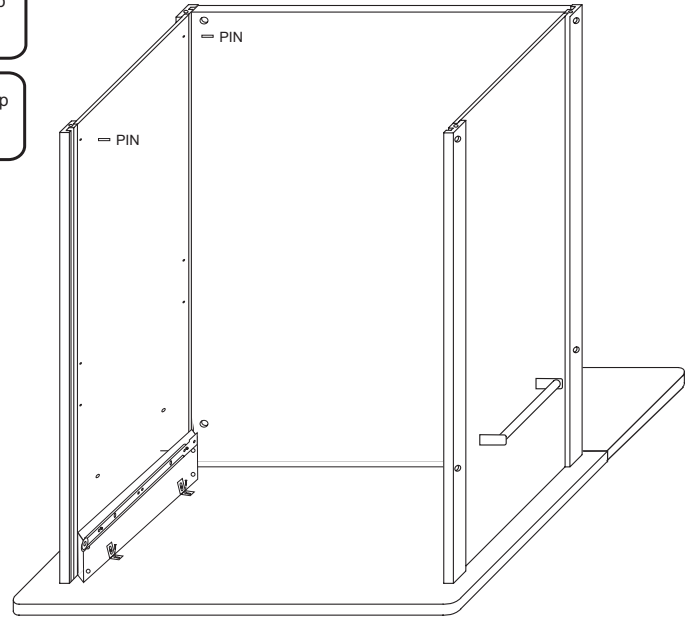
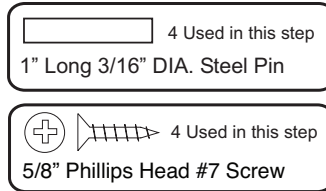

## STEP 6

### Attach Tower Bar to Side Panel

Attach the handle/towel bar to the side panel with 1" #8 screws/washers from inside cabinet.

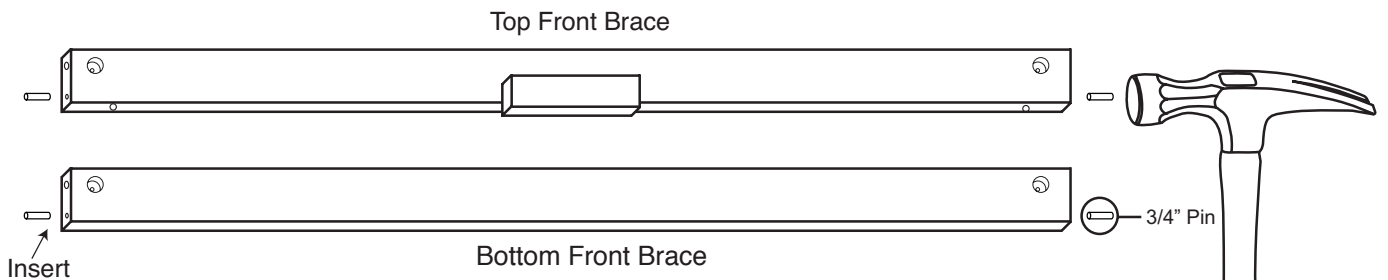
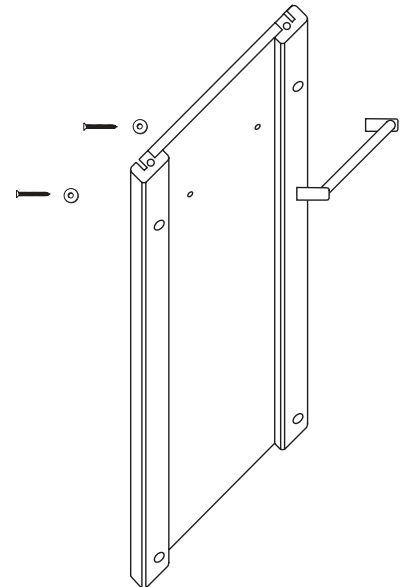
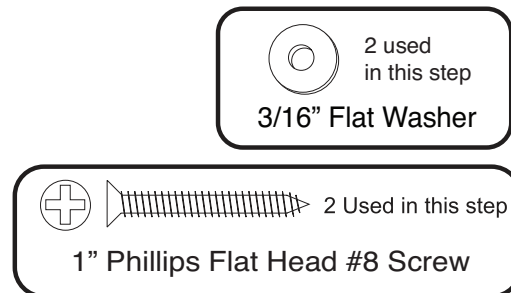

## STEP 7

### Tap Pins Into Brace Ends

Take the 2 front braces and tap/insert one 3/4" steel pin into each end of both braces until seated. About 3/8" will stick out when seated. Ok if loose.

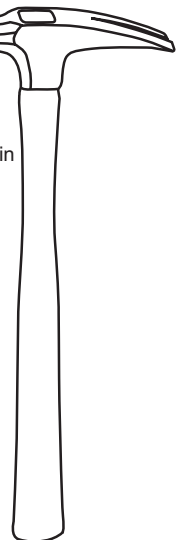
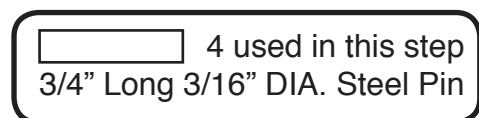

## STEP 8

A. Take the top front brace (with magnet block), insert the pins in the brace ends into the slits on the inside of the front legs and slide down until the brace aligns with the bolt holes.

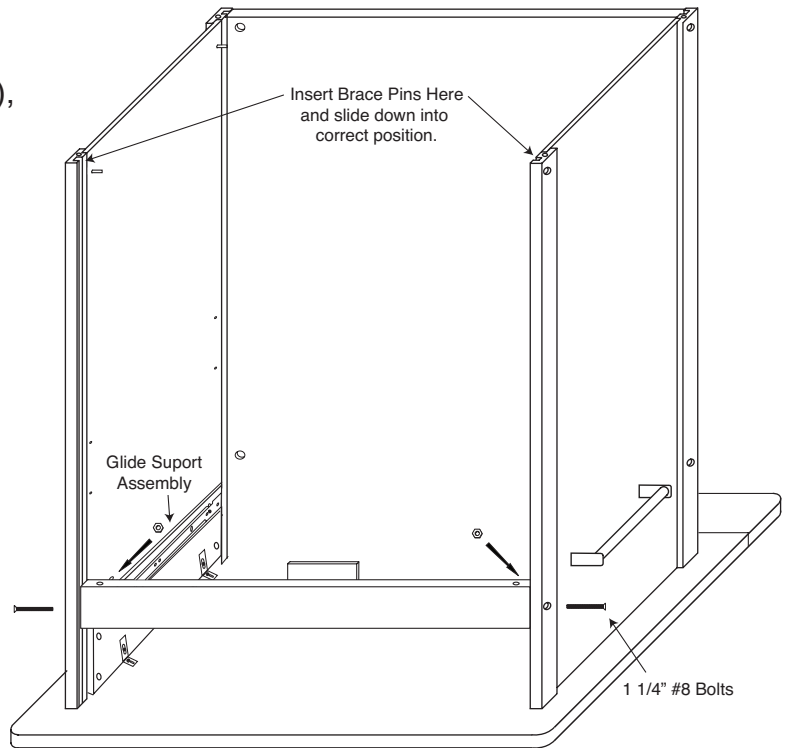
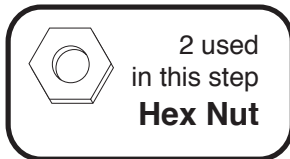

ILLUSTRATION 8



## STEP 9

### Door Prep

A. Insert/Tap ONE 1 1/2" pin into each end of both doors. DON'T OVERDRIVE PINS! Pins should stick up about 1/2" when seated. OK if loose.

B. Attach the door spacer to the left door with 5/8" #8 screws. The spacer has a space at the top to allow magnet clearance and is almost flush with the bottom of the door.

C. Attach the magnet plate (may be stuck to the magnet) with the small FLAT HEAD screw to the top of the right door. Small bumps on plate go next to wood.

D. Attach the door handles with 7/8" Truss Head Machine Screw.

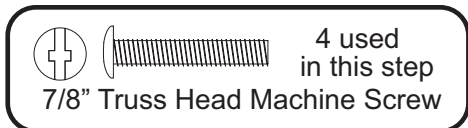
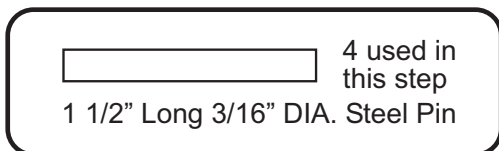
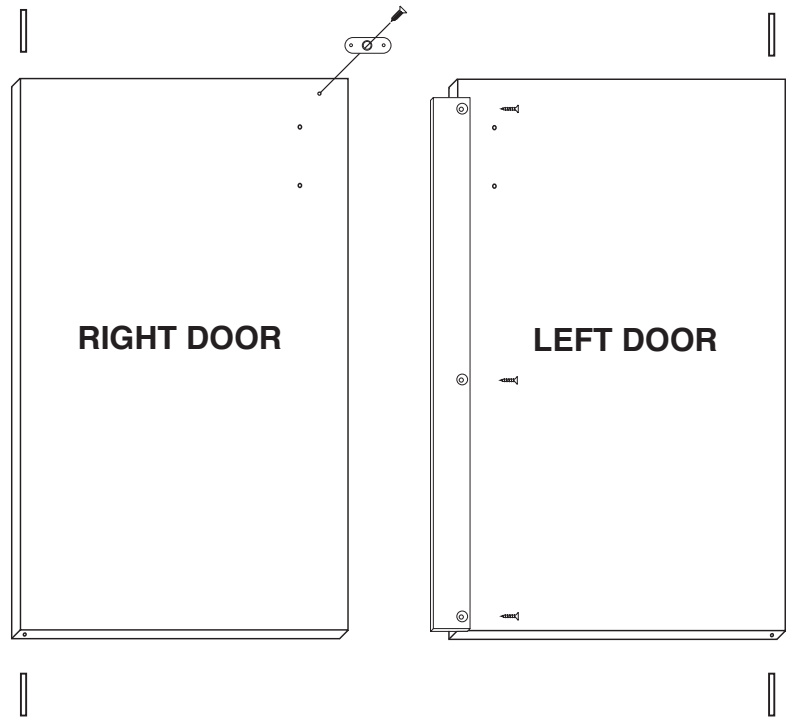

## STEP 10

### Install Doors/Bottom Front Brace

A. Install doors by inserting pins in the door tops into the holes in the top front brace.

B. Place one washer on each of the door pins in the door bottoms.

C. Take the bottom front brace, align pins in door bottoms with holes along top edge of brace (are washers on pins??) and secure brace with 1 3/4" bolts/hex nuts as before.

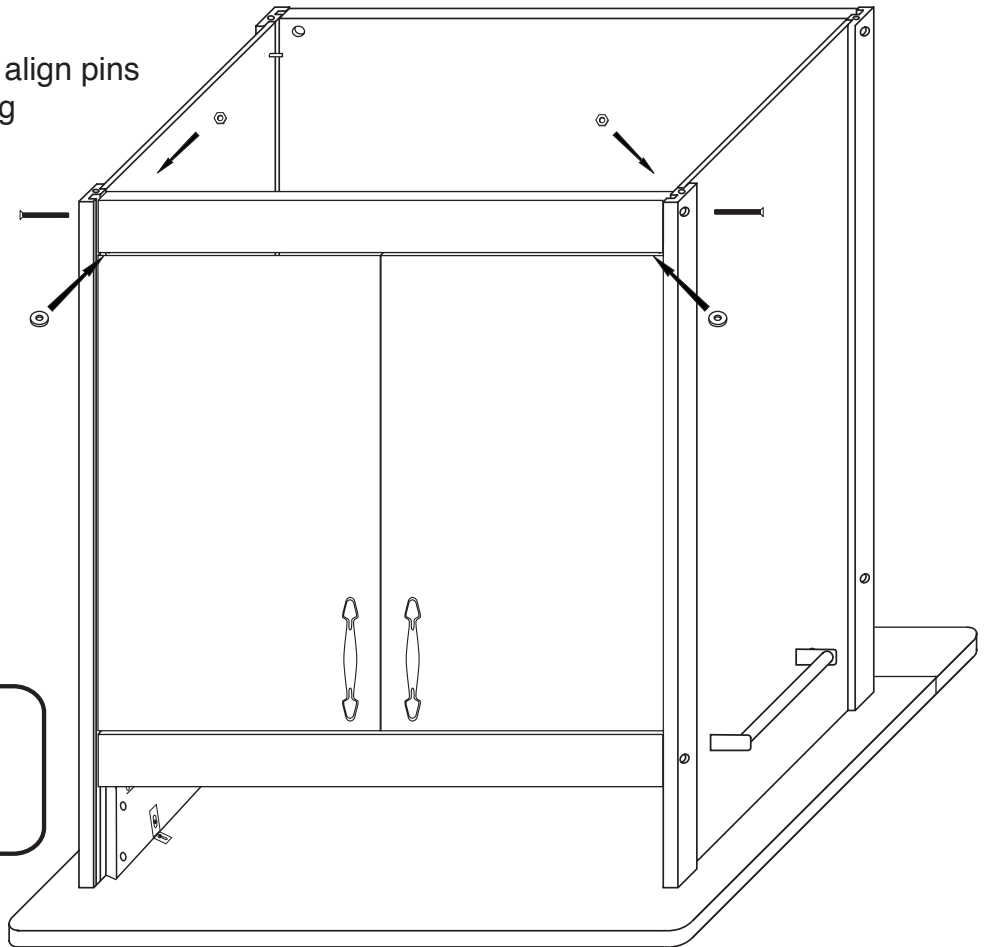

2 Used  
in this step  
10-24 Hex Nut



2 Used  
in this step  
3/16" Flat Washer



1 3/4" Phillips Flat Head Bolt  
2 Used in this step

## STEP 11

### Attach Magnet to Magnet Block

A. Stick magnet to magnet plate on right door.

B. With left door open, close the right door. The magnet should be positioned over the wooden block on the bottom of the top front brace. Hold the magnet in place with your thumb, and open the right door. The magnet will be in the correct position on the block. Mark with a pencil.

C. Secure magnet with the two pan head screws in the magnet packet. Center screws in the slot in the magnet. This will allow adjustment later, if needed.



Magnet

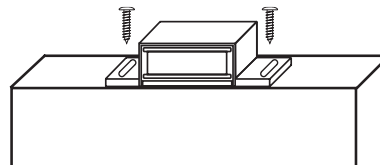

2 Used  
in this step  
5/8" Pan Head Screw

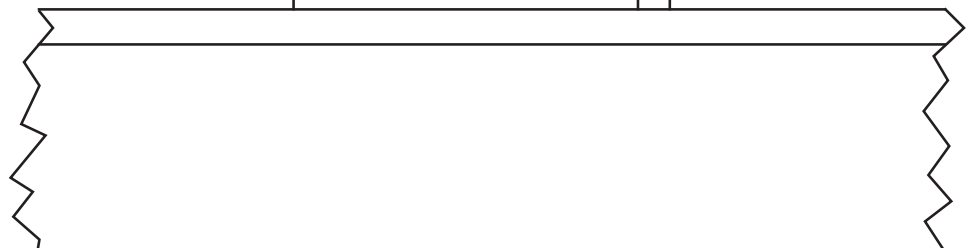



# STEP 12

A. Attach the drawer back to the drawer side with two 1 1/2" #8 screws. The drawer back leave a 1" gap at the top to allow drop leaf support clearance. Make sure parts are aligned as in illustration 12A.

B. Insert drawer bottom into the slots in the drawer sides, best side to inside of drawer. Slide down until seated in the slot in the drawer back. See illustration 12B.

C. Screw the cam posts into the two outside holes on the inside face of the drawer front until seated. Only 3/8" of this post goes into the wood, leaving the 4 larger guide rings/head exposed. See illustration 12C. Visit our website [www.catskillcraftsmen.com](http://www.catskillcraftsmen.com) for a video on cams.

D. Insert the posts into holes in the drawer side until seated against the front ends of the drawer sides. Insert cams so that slot in the cam fits over the post and turn with Phillips screwdriver until seated. Don't over-torque!! See Illustration 12D. See our video online at [www.catskillcraftsmen.com](http://www.catskillcraftsmen.com)

E. Attach drawer handle with the two 7/8" Truss Head screws (no illustration.)

F. Attach drawer glides to drawer sides using 5/8" #5 screws. See illustration 12E. Drawer glides are flush with front of the drawer sides.



ILLUSTRATION 12A

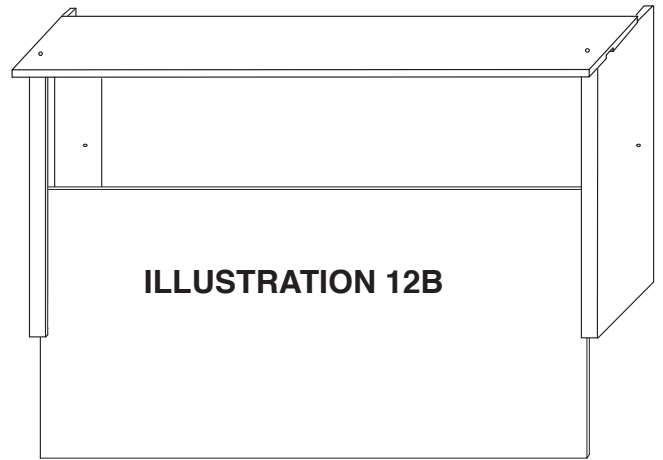

ILLUSTRATION 12B

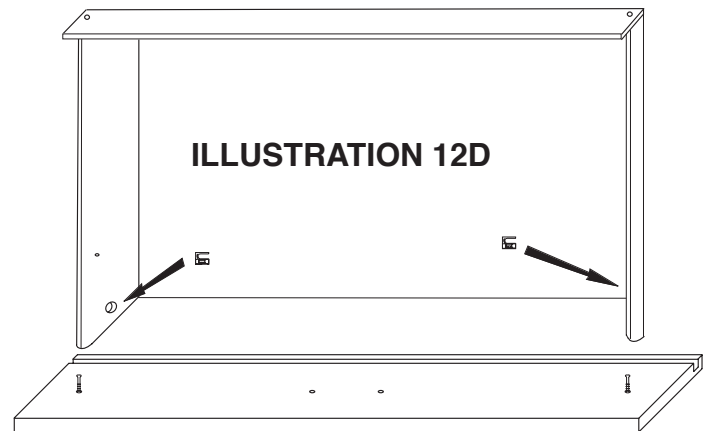

ILLUSTRATION 12D

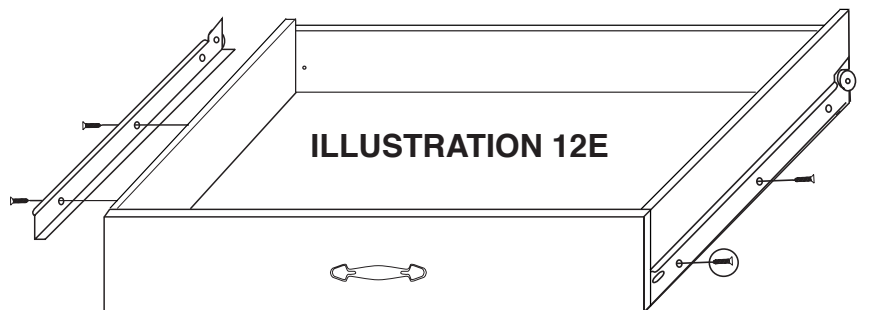

ILLUSTRATION 12E

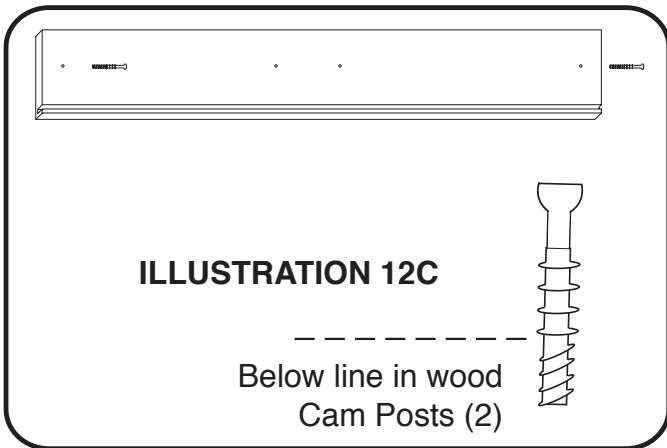
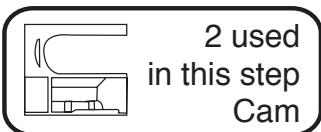
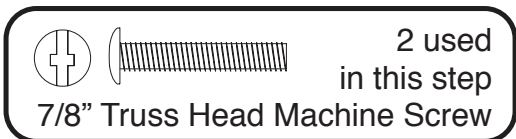
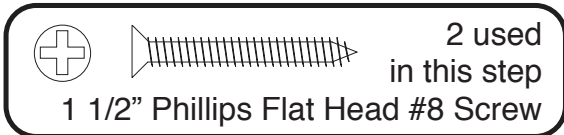

ILLUSTRATION 12C

Below line in wood  
Cam Posts (2)



## STEP 13

### Install Casters

A. Insert and tap caster sockets with a hammer until the teeth grab the wood. **DON'T POUND SOCKET FLAT OR CASTER SHAFT WILL NOT ENTER.**

B. Insert casters and seat by pushing straight downward with the heel of your hand, or tap into place with a hammer. Don't be afraid to give them a good downward whack on the solid metal part of the caster!

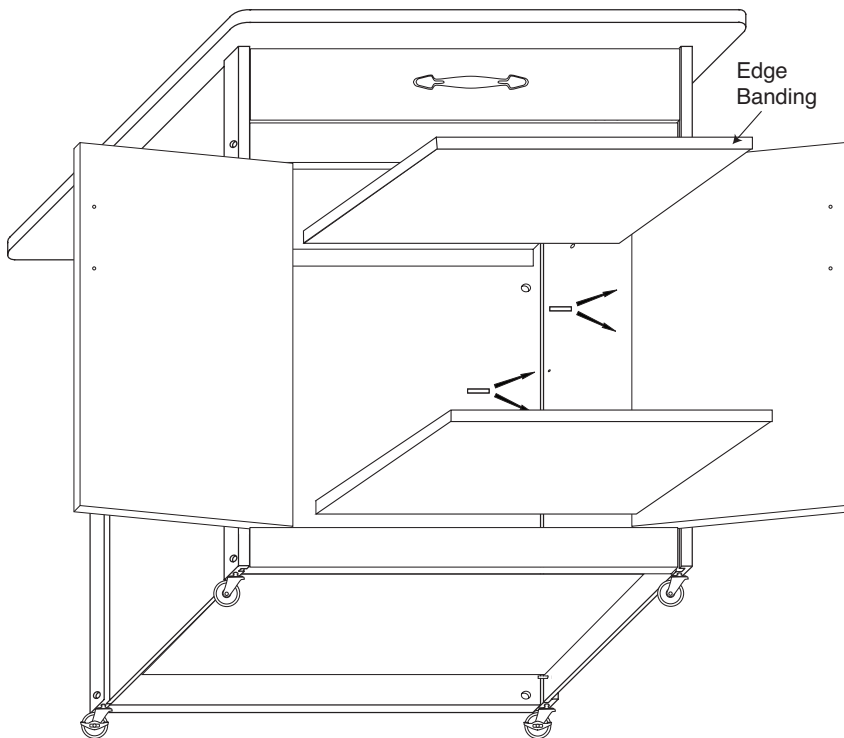
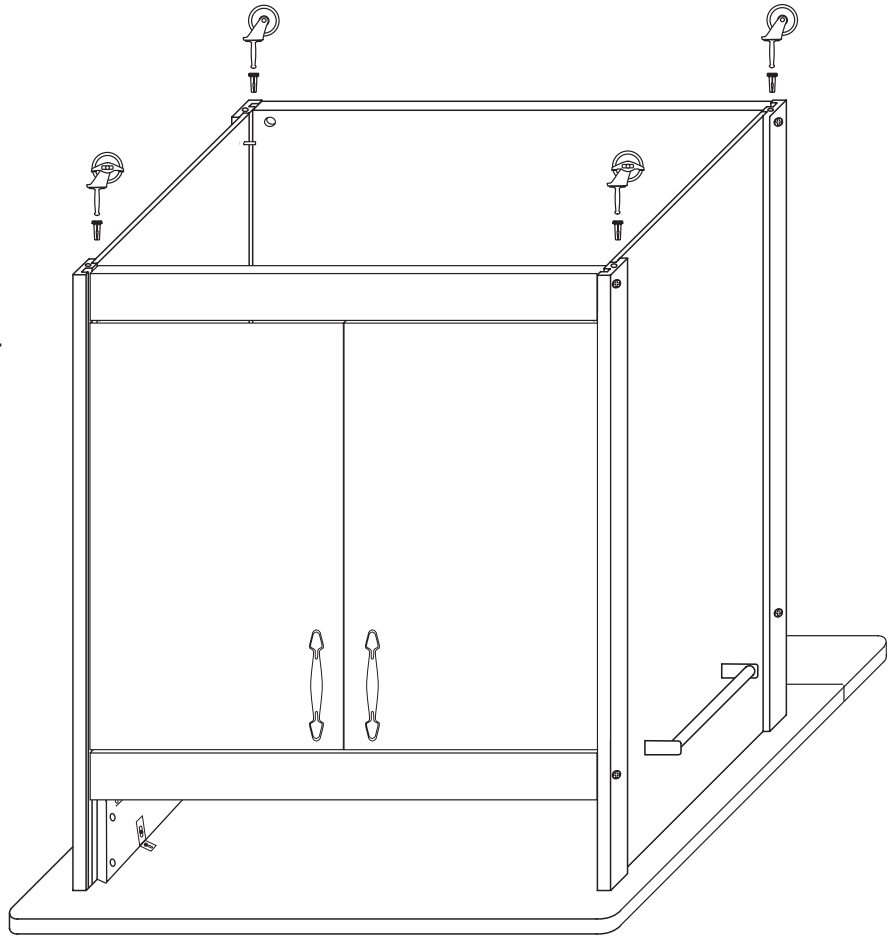

## STEP 14

### Install Shelves/Disks

A. Upright unit. Take bottom shelf (no edge banding) and place it on the set of back pins as shown. Close doors and shelf will drop into place. **DO NOT FORCE!**

B. Tap two 1" pins into each side panel to hold middle shelf, making sure the pins on both sides are in the same relative position. To remove a pin, use pliers or a claw hammer.

C. Place middle shelf, edge banding out, on pins.

D. Insert drawer. If drawer hits the bottom of the cart top or the top front brace, tap the top front brace down, then re-tighten screws and insert wooden disks into sides.



4 used in this step

**1" LONG 3/16" DIA. STEEL PIN**



For continued beauty and long life of your Catskill Craftsmen cart, we recommend Catskill Craftsmen's Butcher Block Oil.

Our Butcher Block Oil is available directly from Catskill Craftsmen's factory. For one eight ounce (8 fl. oz.) bottle, which is sufficient for two applications, simply send \$6.95 along with the completed coupon to the address below. Visit us online at [www.catskillcraftsmen.com](http://www.catskillcraftsmen.com) to browse our assortment of butcher block care products. Visa and Mastercard are accepted online .



Catskill Craftsmen, Inc.  
15 West End Ave.  
Stamford, NY 12167-1296



### BUTCHER BLOCK OIL COUPON

Please send me \_\_\_\_\_ # of bottle(s) of the Catskill Craftsmen Butcher Block Oil at \$6.95 per bottle. My check or money order is enclosed for a total of \$\_\_\_\_\_.

Item code: 51533

Name \_\_\_\_\_

Address \_\_\_\_\_

City \_\_\_\_\_

State \_\_\_\_\_ Zip \_\_\_\_\_

Please make checks payable to Catskill Craftsmen Inc. 15 West End Ave., Stamford, NY 12167-1296