

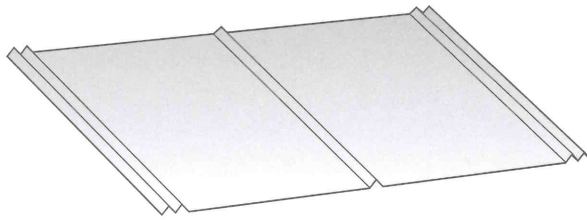

**SEMCO**<sup>TM</sup>  
SOUTHEASTERN METALS

**5-V CRIMP Panel  
Detail Manual**



Custom cut to the inch

Wide variety of colors  
for both panels and flashings

Complete line of accessories

Technical support

**Service**

**800.874.0335**



## Table of Contents

Important Information .....	2
Installation Information .....	4
Technical Information .....	5
Trims and Flashings Illustration .....	6
Roofing Installation Details .....	
Fascia Cover (FC-5/FC-7/FC-9) .....	8
Eave Drip (ED-1) .....	9
Eave Flashing (EF-3) .....	10
Preformed Valley (PV-1/PV-2) .....	11
End Wall Flashing (EW-1) .....	12
Side Wall Flashing (SW-1) .....	13
Transition Flashing (TF-1) .....	14
Gambrel Flashing (GF-1) .....	15
Gable Rake (GR-2) .....	16
Gable Rake (GR-4) .....	17
High Side Eave (HS-2) .....	18
Hip Cap (RC-2) .....	19
Ridge Cap (RC-3).....	20
Ridge Cap (RC-8) .....	21
Vented Ridge with Venturi Vent .....	22
Vented Ridge with Miami Dade Profile Vent .....	23
Pipe Boot .....	24
Fastener Guide .....	25
Sealants and Accessories .....	26
Helpful Formulas .....	27
Flashing Angle Specifier Chart .....	28

## Important Information

### Finishes

**40-year warranted SemCoat Plus** is a fluoroceram premium coating manufactured by BASF/Morton International Inc. It contains 70% Kynar 500 or Hylar 5000 PVDF resin over Galvalume ASTM-A792 structural steel grade 50.

**35-year warranted SemCoat SP** is a siliconized polyester premium coating applied to a galvanized steel substrate coated with zinc (G90). This finish consists of a primer coat top and bottom and the primary color applied to the top of the panel.

Panels are also available in **25-year warranted Acrylic coated Galvalume** ASTM-A792 structural steel grade 50 and non-warranted hot dipped G-90 **galvanized mill finish**. Please note, acrylic coated Galvalume panels may not weather uniformly after installation. This is not a defect in the product or a cause for rejection. If non-uniform weathering is a concern, Southeastern Metals recommends selection of a color-coated panel.

### Colors

For panel color selection, please refer to the Southeastern Metals Metal Roofing Color Chart.

### Job Estimating and Takeoffs

Southeastern Metals offers this valuable service at no charge. In order to complete estimation requests, it is absolutely necessary that Southeastern Metals be furnished with detailed, accurate information and drawings regarding the project prior to assistance.

Southeastern Metals can assist customers in determining the amount and length of material required for the project, but it is the customer's responsibility to review and field verify the material required to complete the project. Southeastern Metals will not be held accountable for incorrect lengths and quantities. Prior to ordering and installing materials, all dimensions should be verified by field measurements.

### Job Site Delivery Available

The job site delivery disclaimer must be completed to use this service.

### Miami-Dade County and Local Code Compliance

Southeastern Metals' 26 Gauge 5V-Crimp products are Miami-Dade County approved and comply with the most recent testing requirements. Contact our technical department for a copy of our current Miami-Dade County NOA compliance report if one is required for your purposes.

Building codes for metal roofing applications vary by county and project. For information regarding pertinent building code requirements and ordinances, contact your local building code organization.

Southeastern Metals acts only as the seller of roofing materials and has no control of the application of materials or the conditions under which they are applied. A registered engineer or architect of record for the project assumes the responsibility of detailing the applications.

### Warranties

**Acrylic coated Galvalume** panels are warranted not to perforate due to red rust for a period of 25 years provided the project installation meets the limitations detailed in Southeastern Metals' warranty document. For full warranty coverage, panels must be installed more than one mile from an aggressive environment such as, but not limited to, salt water. Those projects within a 1/2 mile to one mile proximity of an aggressive environment are covered by a five-year warranty. Due to the characteristics of the coating, cosmetics cannot be controlled and are not covered by the warranty.

**35-year SemCoat SP** panels are warranted against paint peel, check, chip, or crack resulting from a manufacturer's defect for a period of 35 years from the date of invoice provided the project installation meets the limitations detailed in Southeastern Metals' SemCoat SP warranty document. For full warranty coverage, panels must be installed more than one mile from an aggressive environment such as, but not limited to, salt water. Those projects located within a 1/2 mile to one mile proximity of an aggressive environment are covered by ten year warranty. Excessive, non-uniform chalk and fade are covered for the first 10 years.

**40-year SemCoat Plus** panels are warranted against paint peel, check, chip, or crack resulting from a manufacturer's defect for a period of 40 years from the date of invoice providing the project installation meets the limitations detailed in Southeastern Metals' SemCoat Plus warranty document.

### **Delivery, Handling and Storage**

Proper care in storing and handling metal panels is essential in providing you with years of service. Panels should be installed immediately to prevent storage oxidation or paint peel. Any panels not immediately installed must be kept dry and stored in an indoor area. Extreme caution should be taken in order to prevent moisture penetration of the stack(s) by rain, snowfall or condensation. Condensation is moisture that accumulates naturally from the change in temperature of the material nested in a stack where adequate ventilation has been restricted.

Store the panels off the ground, on wooden blocks with one end slightly elevated. Cut banding to allow the stack to expand and allow a small amount of ventilation. Cover the stack with loose canvas tarp or waterproof paper. Covering should be placed over the stack but never tightly secured to the ground to allow air flow. Do not cover metal with plastic as this can create condensation.

### **Safety Precautions**

It is the responsibility of the buyer to ensure the safe installation of these product systems. Metal panels have sharp edges, therefore protective clothing and gloves should be utilized. To prevent eye injury, safety glasses must be worn when drilling or cutting steel panels. Steel panels can become slippery when wet. Use extreme care when walking on any roofing panel. Proper underlayment is necessary to prevent fall-through. Plywood is recommended on all non-structural panel applications. Do not work on steel panels when wet or when weather conditions are not suitable for safe installation.

Southeastern Metals recommends all installers comply with the Florida Fall Protection Act, all OSHA (Occupational Safety & Health Administration) requirements (#3146, dated 1995), and any other applicable safety rules or laws.

### **Cancellations**

Southeastern Metals will honor cancellation prior to manufacturing. Any order which has already been manufactured is the property of the purchaser.

### **Claims**

All claims of shortage, damage, etc. must be made within 48 hours of the date of receipt. Claims must be accompanied by a copy of the bill of lading verified by the shipper which must indicate shortages or damages as received. Southeastern Metals can not honor shortage or damage claims on freight carriers unless the carrier's paperwork is duly noted.

### **Disclaimer**

The information contained in this product manual is subject to change without notice. Southeastern Metals reserves the right to discontinue or modify products and installation methods at any time without notice and incurring no obligation. Contact Southeastern Metals to obtain the latest information.

5V-Crimp metal roofing panels are prone to oil canning, a wavy distortion in the flat or nearly flat area of the panel. Oil canning will not be considered a reason for rejection or claim.

Throughout this product manual each panel series is specified per Southeastern Metals recommended use and application of these products. The use of these products should not vary from these recommendations or should not be applied using another manufacturer's specifications or guidelines. If you have any questions about any of the products and their appropriate applications, please call Southeastern Metals.

**NOTICE:** The application details are for illustration purposes only. These details may not be suitable for all building designs or conditions. Projects should be engineered to confirm to building codes, regulations, and industry practices which are applicable. Consult Southeastern Metals for any additional information not outlined in this manual.

## Installation Information

### Panel

There are three critical measurements involving roof panels: the length required at the eave, the peak end and the amount of panel lap (if required). In each case a certain measurement is required. Check each measurement to ensure panel placement gives you the distance required at the eave, peak and endlap condition (if required). In most cases any variance can be taken out at the eave and peak.

### Accessories

This publication details the standard line of trims and accessories for 5V-Crimp roofing applications. Additional trims, including custom accessories, are available upon request.

### Substrate

In residential applications, Southeastern Metals' recommends the use of minimum 15/32 plywood or 7/16 OSB decking. In addition, we specify a 30# felt be installed in accordance with local building code requirements to control condensation. **NOTE:** Southeastern Metals does not recommend the use of square headed cap nails. If tin tabs are used to secure the 30# felt to the decking material, Southeastern Metals' recommends a separation sheet of 15# felt or rosin paper be used over the 30# felt, applied in the same direction as the panels. If the building parameters differ from those stated in the manufacturer's recommended fastening schedule, specific fastening calculators must be computed by the engineer of record.

### Metal Re-Roofing Over Shingles

Southeastern Metals' metal roofing panels may be installed over existing asphalt shingles, provided the roof decking integrity has been confirmed to be free of any moisture decay that would prevent un-levelness or fastener pull out capacity. **NOTE:** Ordinances regarding roofing applications over existing shingles vary by county and state. Check your local building code organization for more information.

The panels may be applied directly over one layer of existing shingles, provided a separation sheet is installed on top to the shingles. We require a minimum 30# felt installed in the same direction as the panels.

Metal roofing can also be separated from the moisture barrier by optional 1" x 3" battens as furring, spaced a maximum of 16" on center and fastened according to our recommended application details. **CAUTION:** Direct contact between pressure treated lumber and metal roofing must be avoided to prevent corrosion.

### Metal Roofing Fire Resistance Ratings

Southeastern Metals' metal roofing panels have been analyzed for fire resistance ratings according to test criteria set forth by Underwriters Laboratories "Standard Fire Tests of Building Construction and Materials" (ANSI/UL 263), and ASTM E119 and NFPA 251.

The fire resistance rating is for the total assembly and not just the external metal roofing panels. In general, the test criteria is to evaluate the assemblies ability to continue to support the imposed loads and to resist the passage of flame, high temperature, or hot gasses which will ignite combustible sub-assembly, framing, or decking materials from an exterior source. For detail information on specific assembly ratings see the UL Fire Resistance Directory.

Attaining a class "A" or "B" fire rating requires the installation of one of the following - a minimum 1/4" thick Georgia Pacific "Dens Deck"; a minimum 4mm thick Partek Insulation's, Inc. "Roctex"; a minimum 52 1/2# Elks "Versa Shield"; a minimum 5/8" water resistant type X gypsum sheathing with treated core and facer; or any other product with a current product approval - over the combustible deck prior to installing the metal roofing panels.

### Trimming and Cutting Steel Panels

Whether cutting with the profile (length-wise) or across the panel (width wise), it is best to use an electric nibbler, shears or hand tin-snips. It is very important to cut panels one at a time with the finish side of the panel facing down on wood blocks. Care should be taken to ensure that the hot metal particles and filings from cutting and securing the panel do not become embedded in the panel.

**CAUTION:** Filings from screw and panel cuttings must be cleaned off the panel after screws have been applied through the panel to avoid rust marks or "bleeding" on the panels. Failure to comply with the above procedures relieves Southeastern Metals, and its parent company, Gibraltar Industries, of responsibility for any resulting damage to, or deterioration of the finish and voids any paint or finish warranty.

# Technical Information

## 5V-Crimp Panel

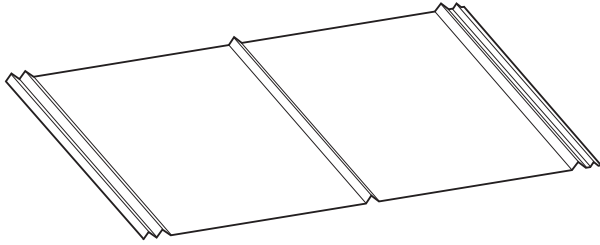

### Testing Data and Specifications

Accelerated Testing of coating 2000 hours per ASTM G23.  
 Salt Spray testing of coating 1000 hours per ASTM B117.  
 Fire Testing per ASTM E108 or UL790.  
 Wind Driven Rain Test per TAS 100.

### Code Approvals <sup>1</sup>

UL Fire Resistance Directory # R20735  
 UL Maximum Design Pressure Listing # R20735  
 Miami Dade Code Approval NOA # 07-0815.06  
 Florida Building Code Approval # FL-11931.1 (26 Gauge)  
 # FL-11937.1 (29 Gauge)

### Profile Detail

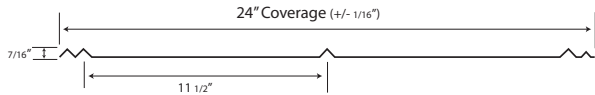

### Sidelap Detail

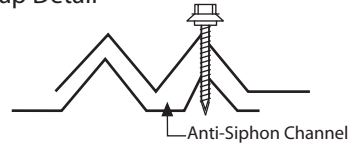

## Recommended Fastening Schedule

Maximum Tested Design Pressures <sup>1,2,3,4</sup>				
Plywood/ OSB Decking Min. 15/32" outside Miami-Dade Min. 19/32" in Miami-Dade	Field Zone 1	Perimeter and Corners Zone 2 and Zone 3		
		Maximum Design Pressure	-67.25 psf	-67.25 psf
Maximum Fastener Spacing	16" on center	16" on center	12" on center	8" on center

1. Extrapolation and rational analysis by a Florida Licensed Architect or Structural Engineer is allowed outside the Miami-Dade HVHZ compliance area. 2. Extrapolation and rational analysis shall not be allowed above the maximum tested design pressures within the Miami-Dade HVHZ compliance area. 3. Interpolation is allowed between Field and Perimeter & Corner test pressure values. 4. For corresponding wind speeds, refer to table 1609.6.2.1(2) of the Florida Building Code. 5. The stated design pressure can only be achieved by using 19/32" Plywood or OSB decking.

### Roof Zones

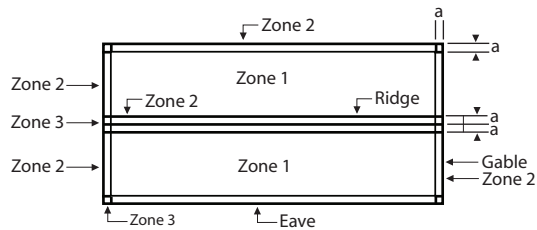

Note: Dimension (a) is defined as 10% of the minimum width of the building or 40% of the mean height of the roof, whichever is smaller, however, (a) cannot be less than either 4% of the minimum width of the building or 3 feet.

### O.C. Spacing and Fastening Detail

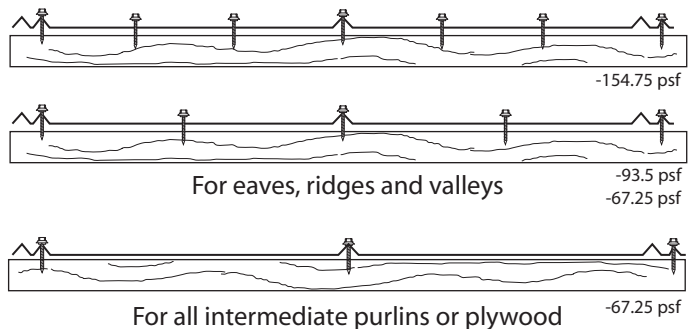

1. Code Approval numbers may have changed since publication. For the most recent code approval numbers, contact Southeastern Metals' Technical Department or refer to the appropriate code agency.

# Trims & Flashings

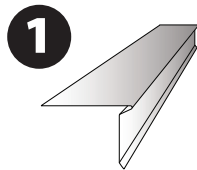

**1**  
Eave Drip/Eave Flashing  
ED-1/EF-3

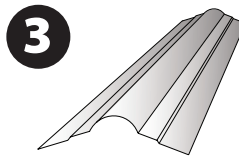

**3**  
Ridge Cap  
RC-3

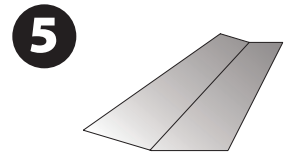

**5**  
Transition Flashing  
TF-1

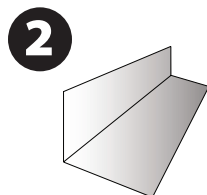

**2**  
End Wall Flashing  
ED-1/EF-3

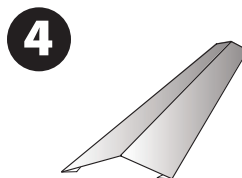

**4**  
Ridge/Hip Cap  
RC-2 or RC-8

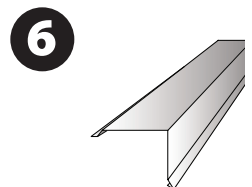

**6**  
Gable Rake  
GR-2/GR-4

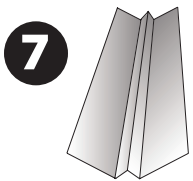

**7**  
**Preformed Valley**  
PV-1 or PV-2

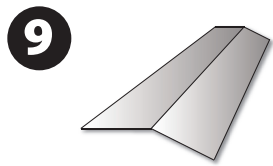

**9**  
**Gambrel Flashing**  
GF-1

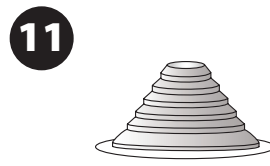

**11**  
**Pipe Boot**

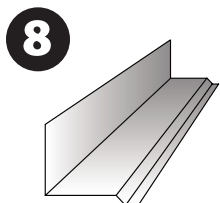

**8**  
**Side Wall Flashing**  
SW-1

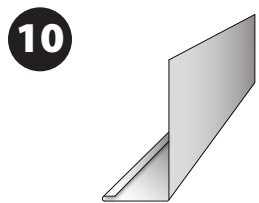

**10**  
**Fascia Cover**  
FC-5/FC-7/FC-9

*\*See Page 26 for accessories used when installing these trims and flashings.*

*\*Additional and custom trims are available. Please call Technical support for more information.*



## Fascia Cover FC-5/FC-7/FC-9 (10' Lengths)

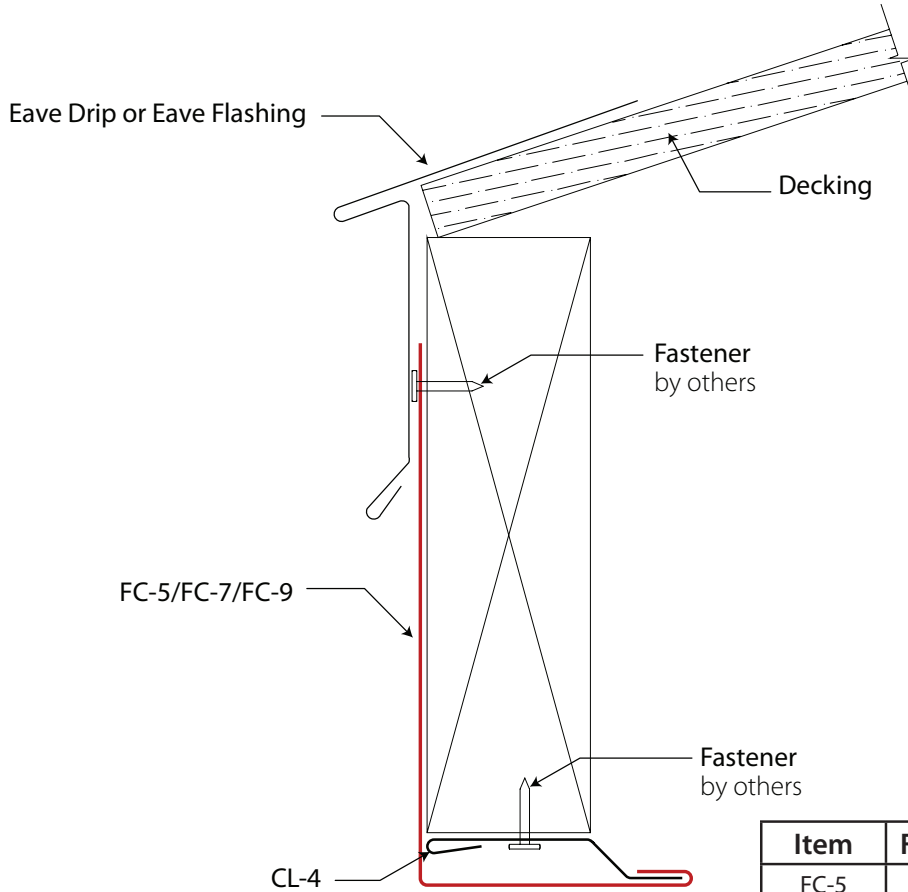

Item	Fascia Size	"A"
FC-5	2" x 6"	5"
FC-7	2" x 8"	7"
FC-9	2" x 10"	9"

## Component Details

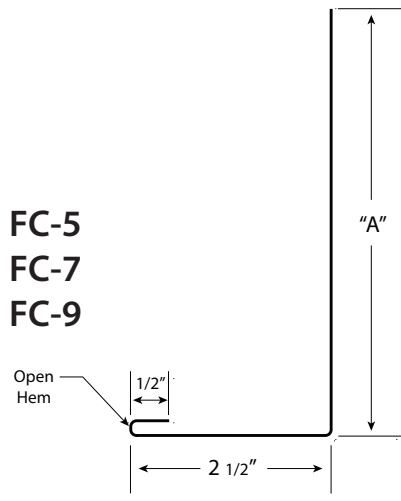

### Cleat CL-4

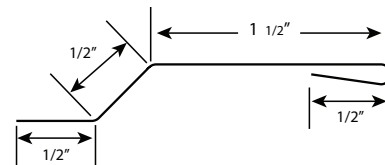

## Eave Drip ED-1 (10' Lengths)

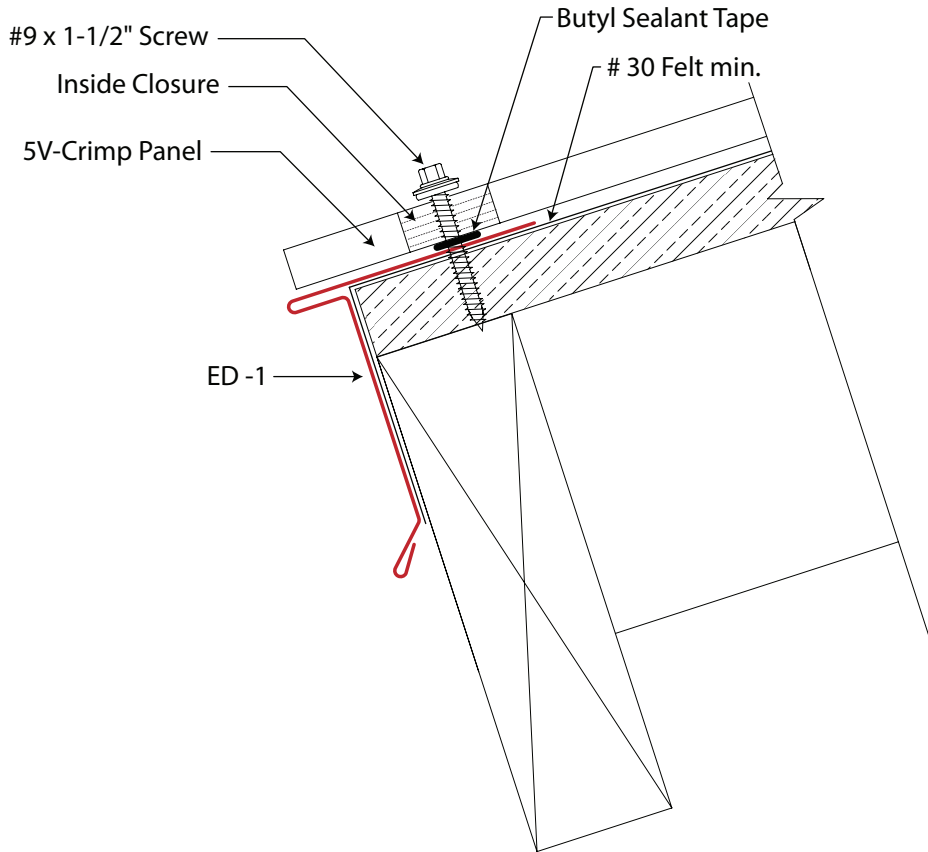

## Component Details

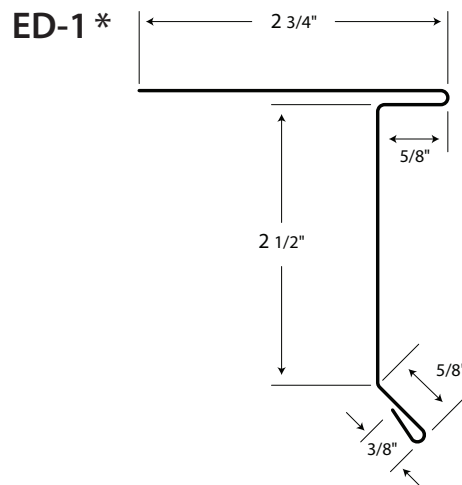

\* See page 28 for angle specification

**5V-Crimp**

## Eave Flashing EF-3 (10' Lengths)

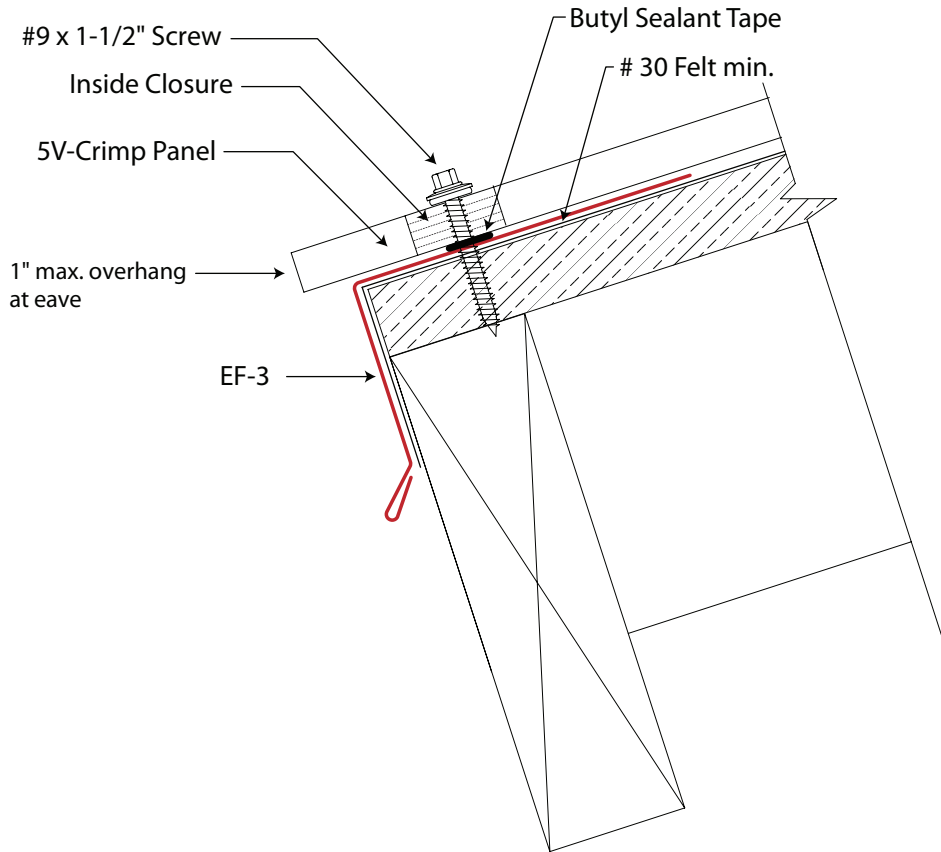

## Component Details

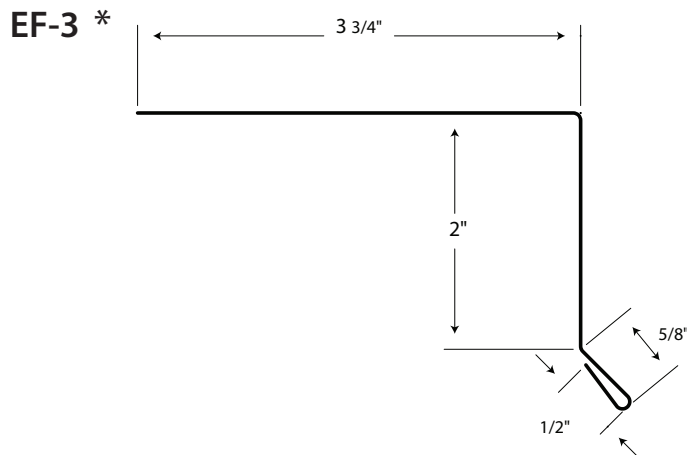

\* See page 28 for angle specification

## Preformed Valley PV-1/PV-2 (10' Lengths)

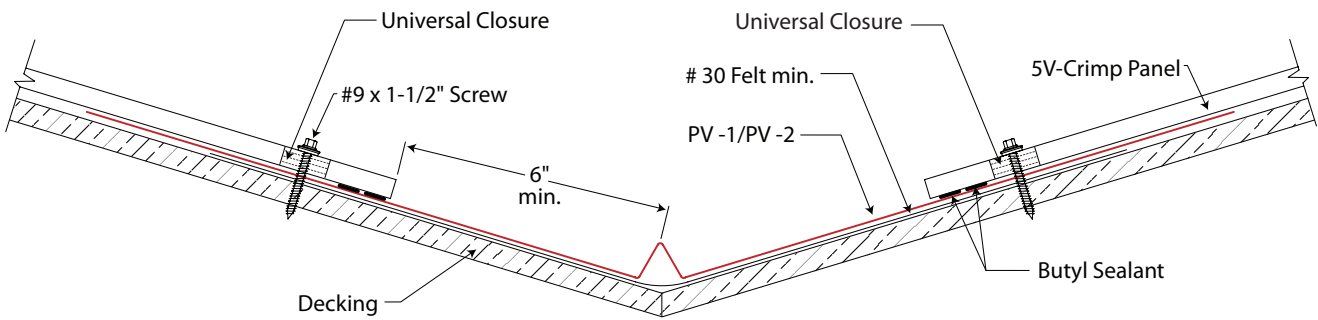

## Component Details

**PV-1 - Unhemmed \***

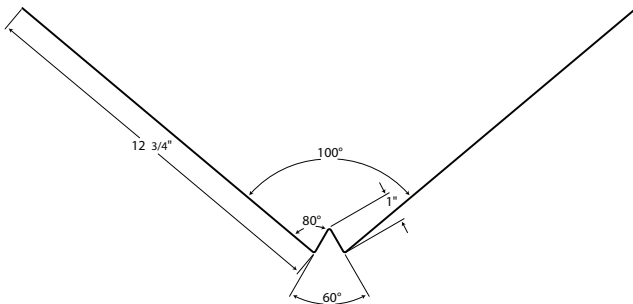

**PV-2 - Hemmed \***

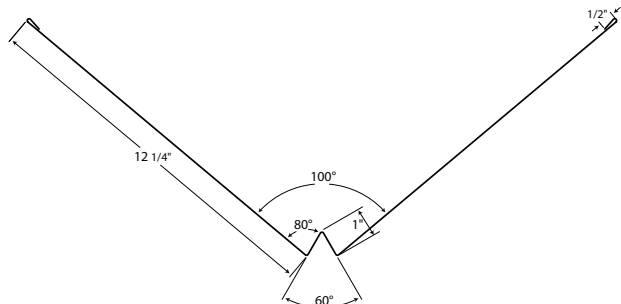

\* See page 28 for angle specification

## End Wall Flashing EW-1 (10' Lengths)

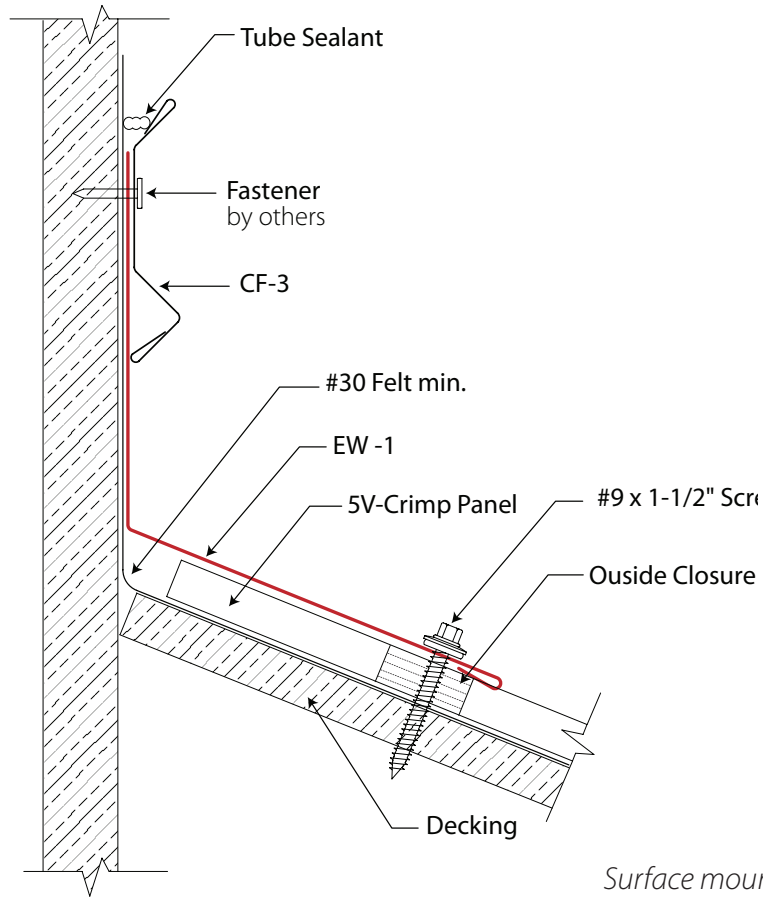

Surface mounting requires use of Counter Flashing (CF-3)

## Component Details

EW-1

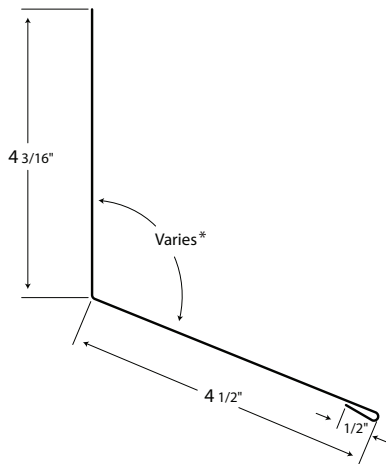

CF-3

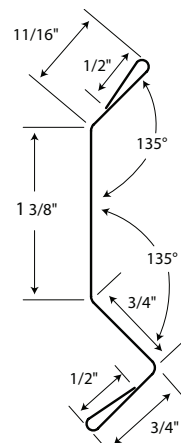

\* See page 28 for angle specification

## Side Wall Flashing SW-1 (10' Lengths)

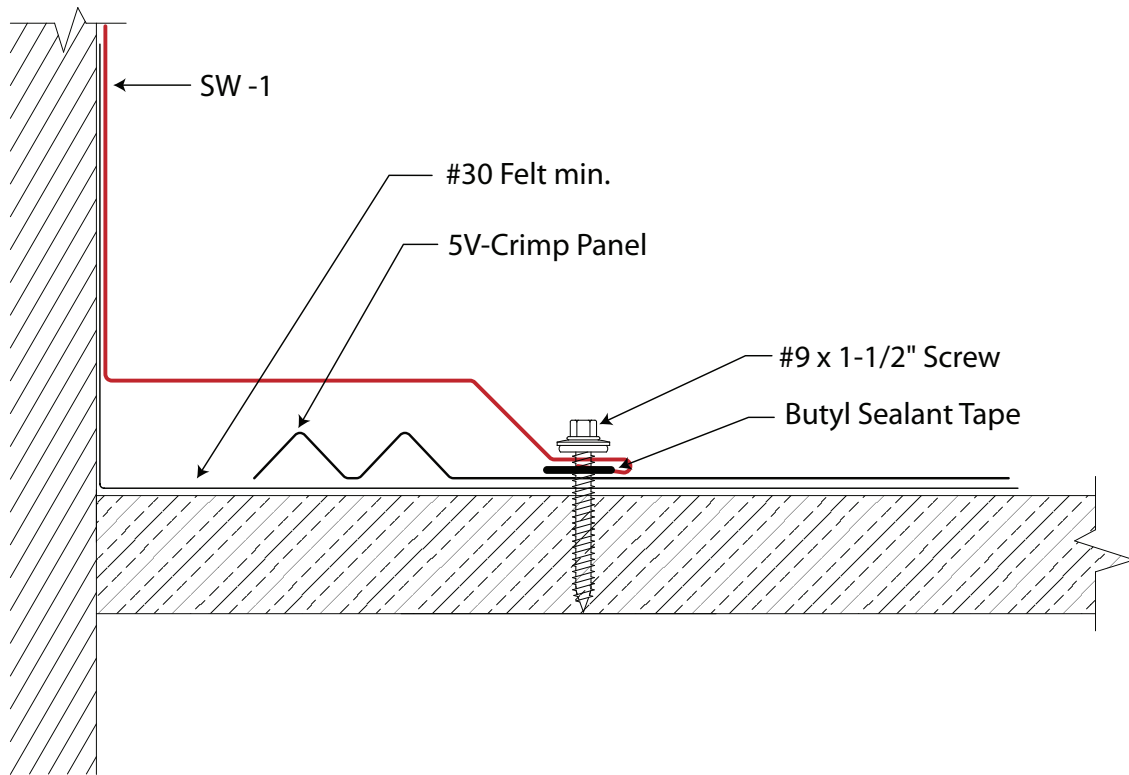

*Surface mounting requires use of Counter Flashing (CF-3)*

## Component Details

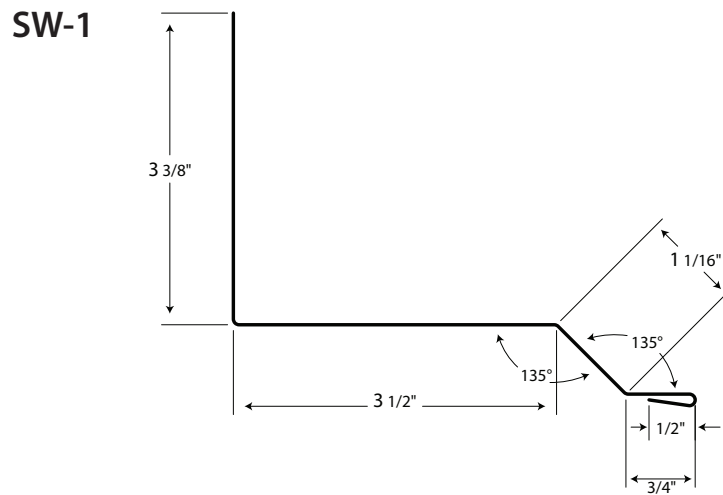

**5V-Crimp**

## Transition Flashing TF-1 (10' Lengths)

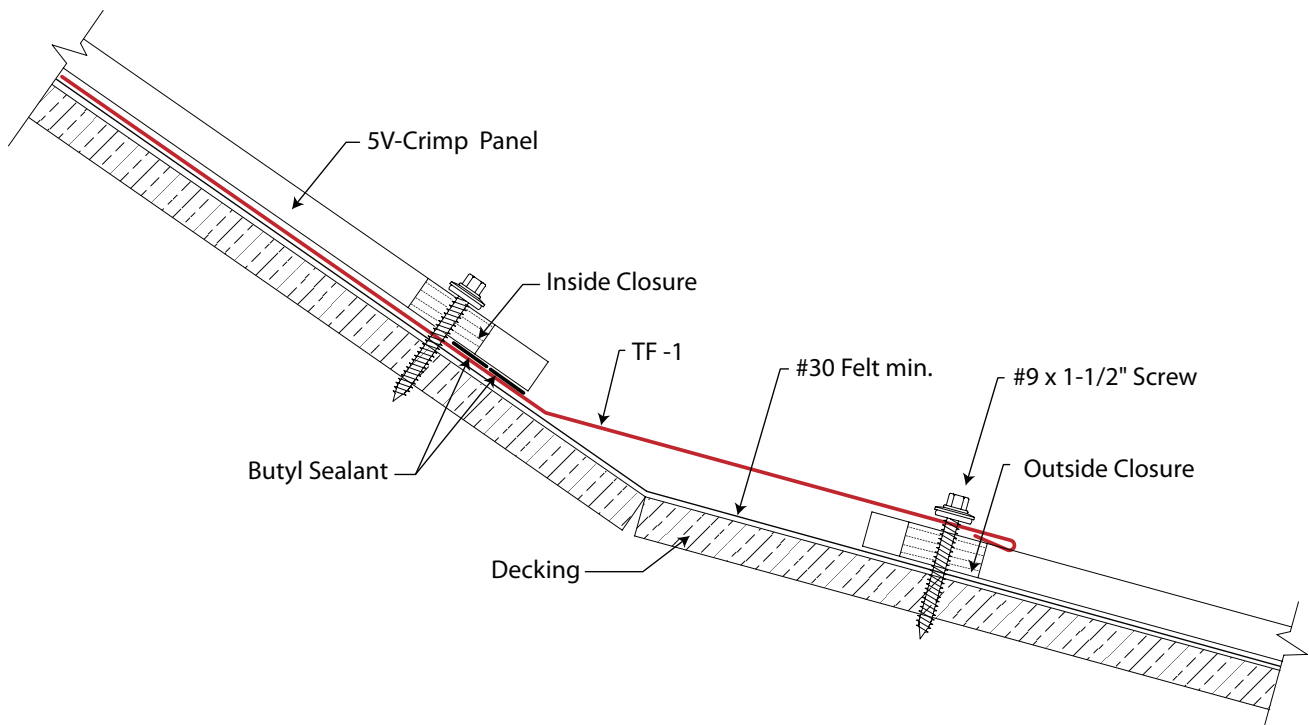

## Component Details

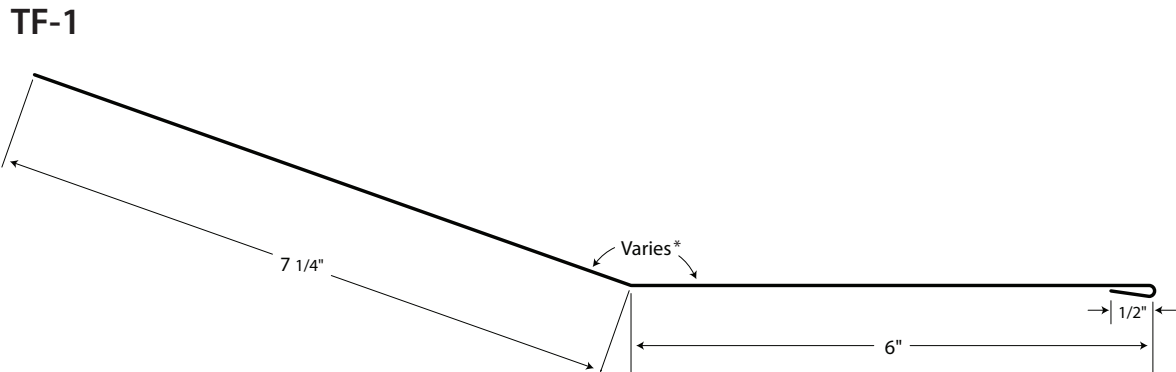

\* See page 28 for angle specification

## Gambrel Flashing GF-1 (10' Lengths)

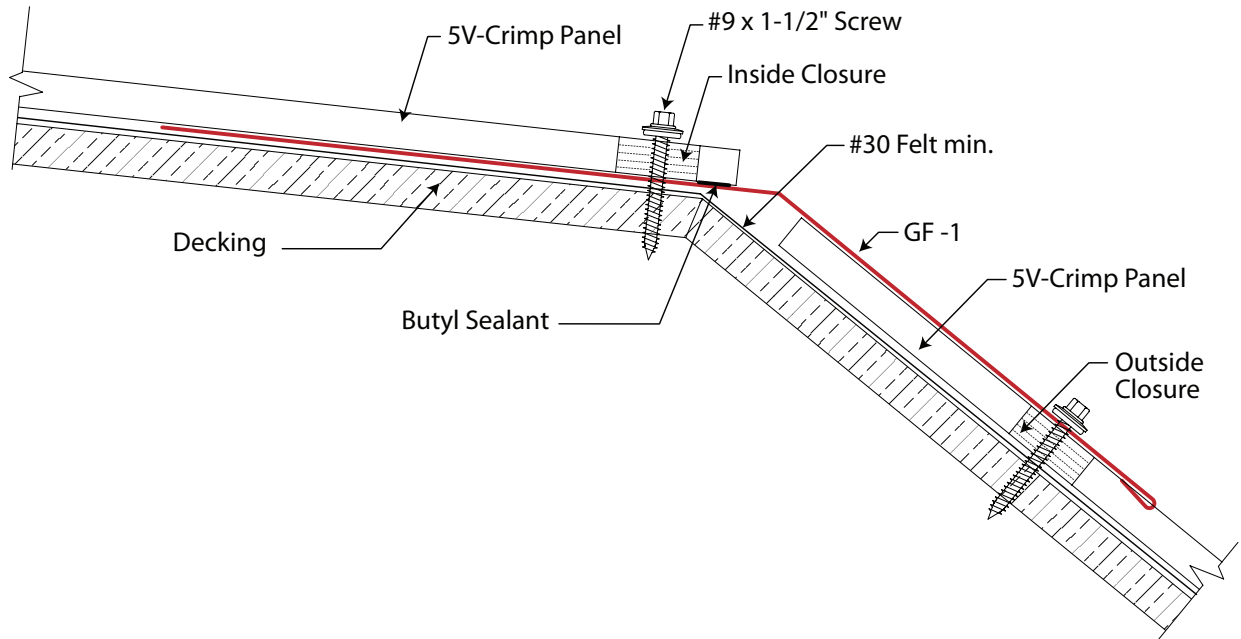

### Component Details

GF-1

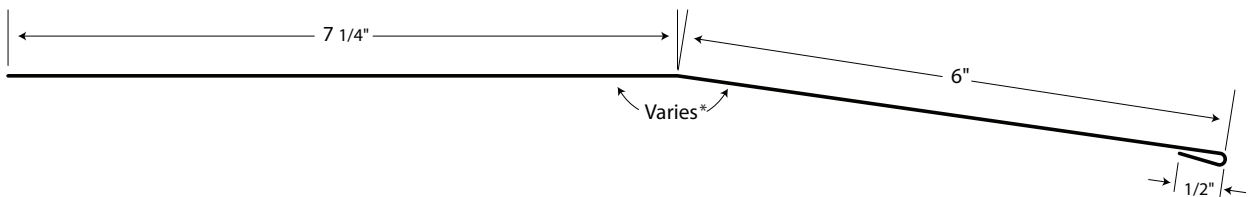

\* See page 28 for angle specification

**5V-Crimp**



### Gable Rake GR-2 (10' Lengths)

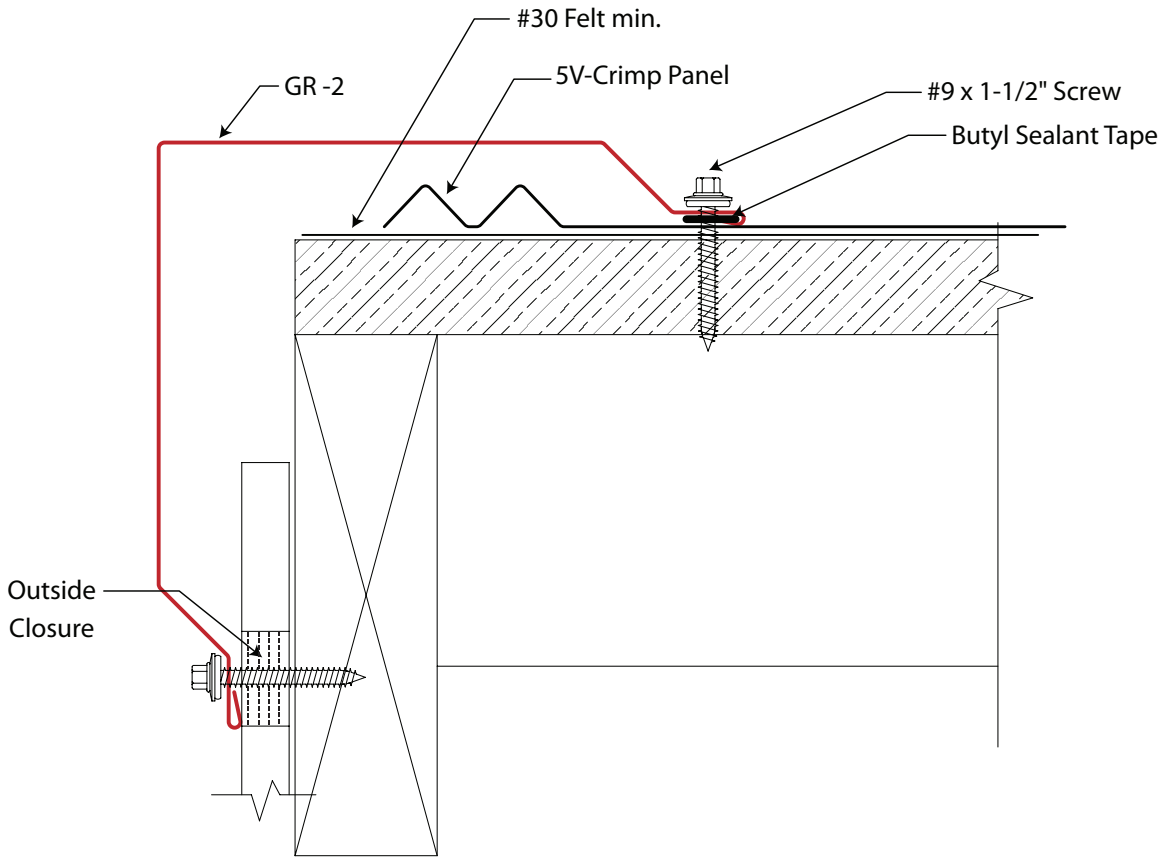

### Component Details

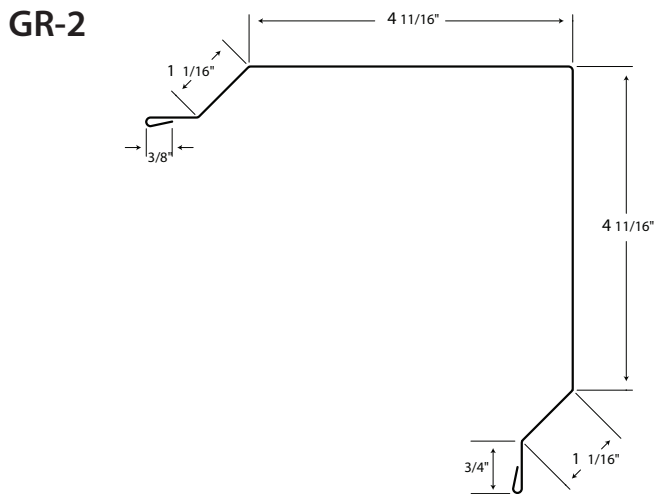

## Gable Rake GR-4 (10' Lengths)

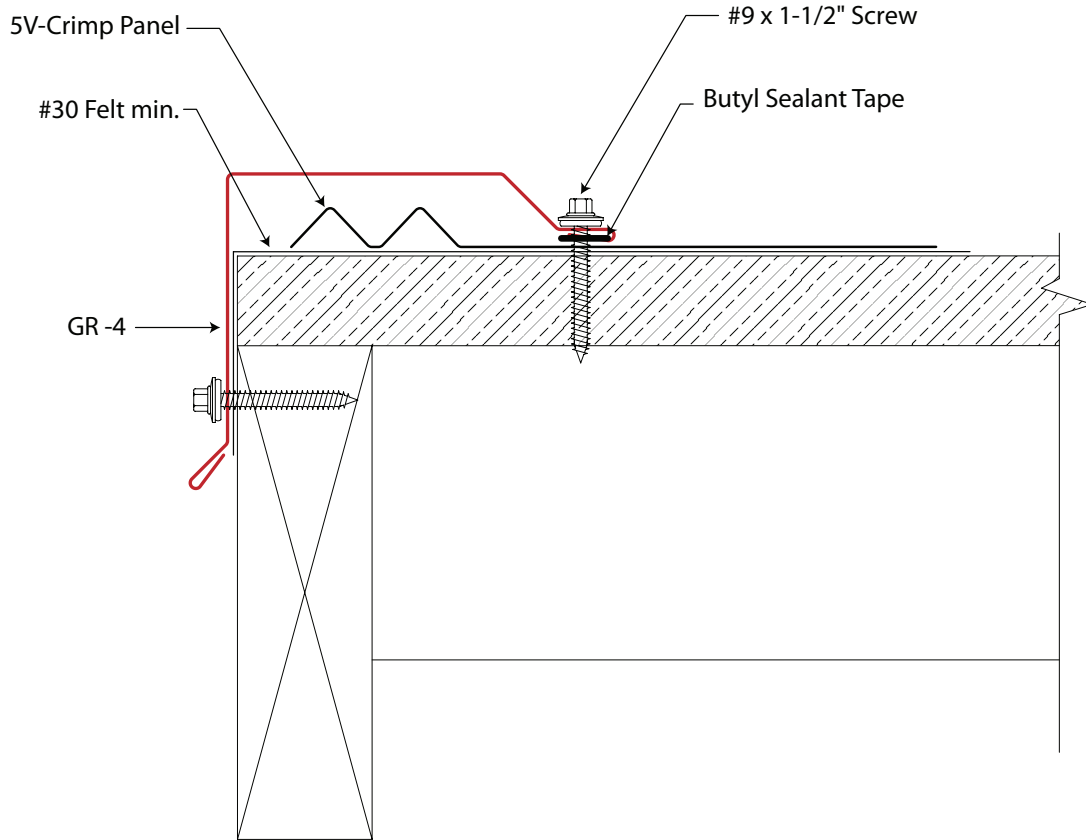

## Component Details

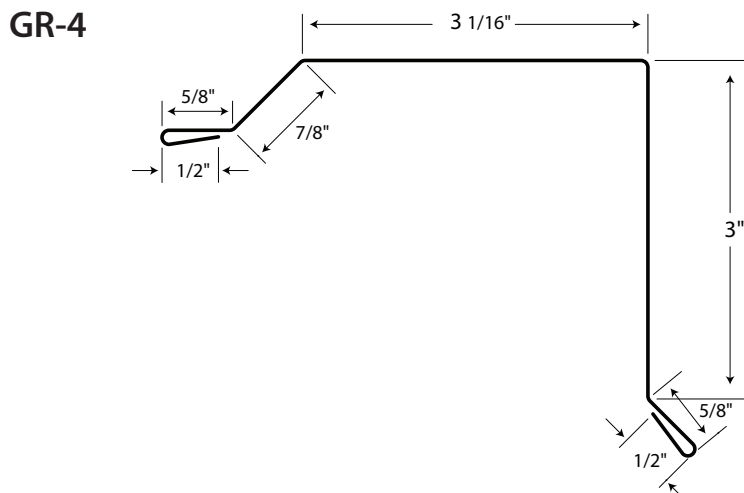

**5V-Crimp**

## High Side Eave HS-2 (10' Lengths)

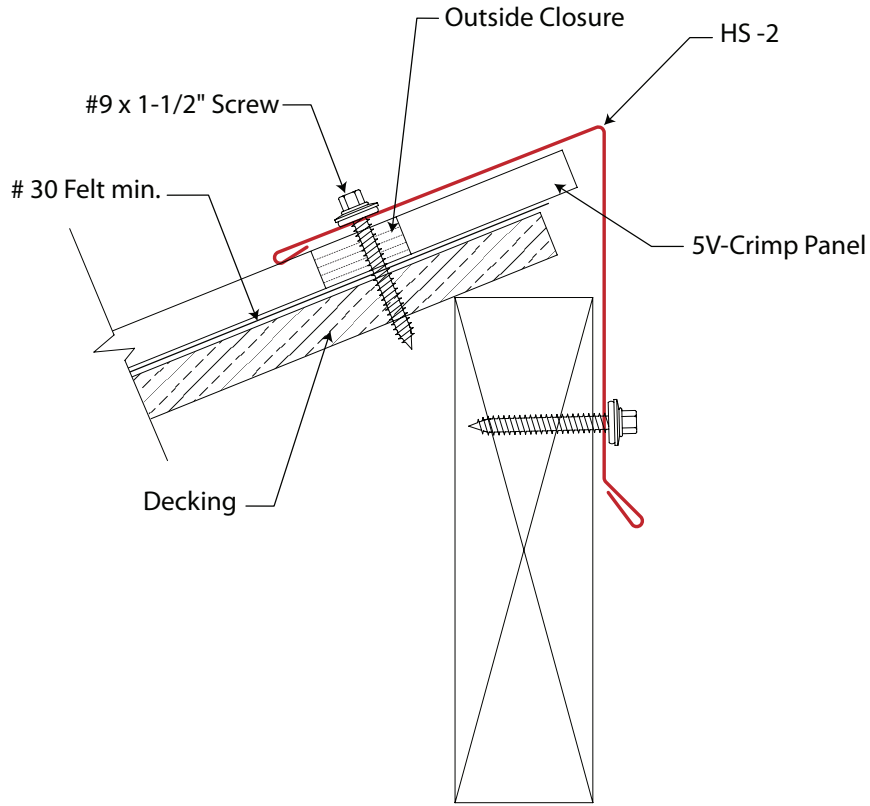

## Component Details

HS-2\*

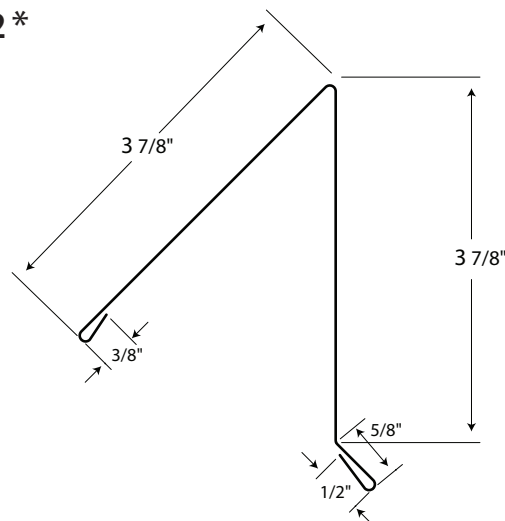

\* See page 28 for angle specification

## Hip Cap RC-2 (10' Lengths)

### Option 1

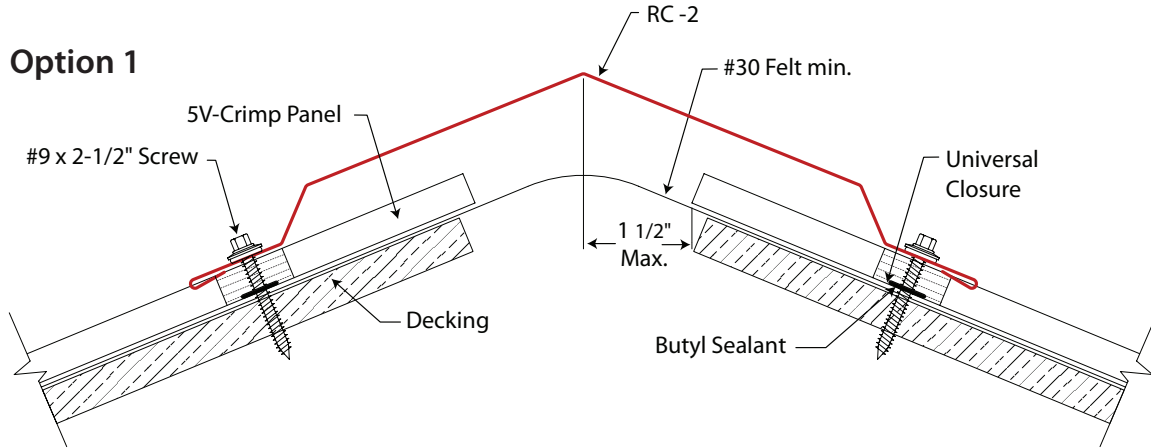

### Option 2

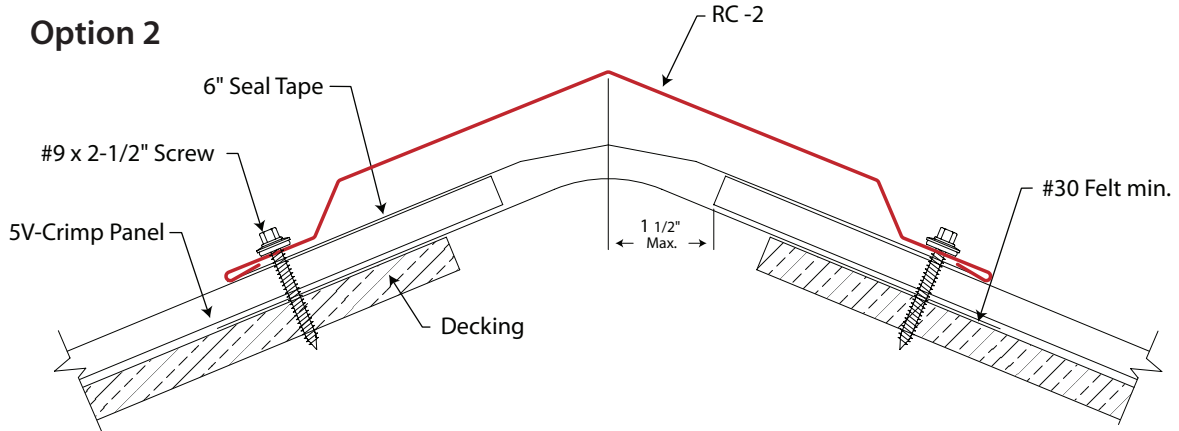

## Component Details

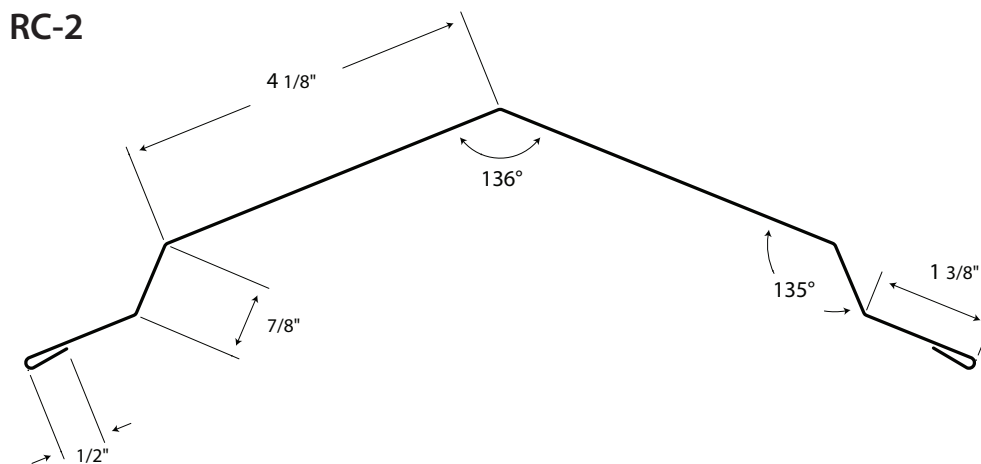

## Ridge Cap RC-3 (10' Lengths)

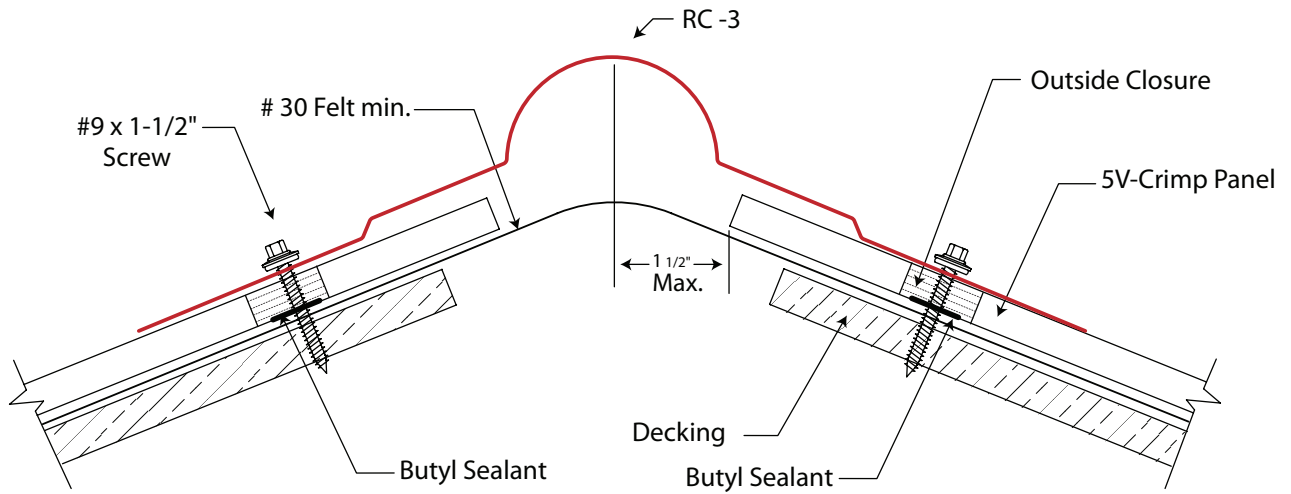

## Component Details

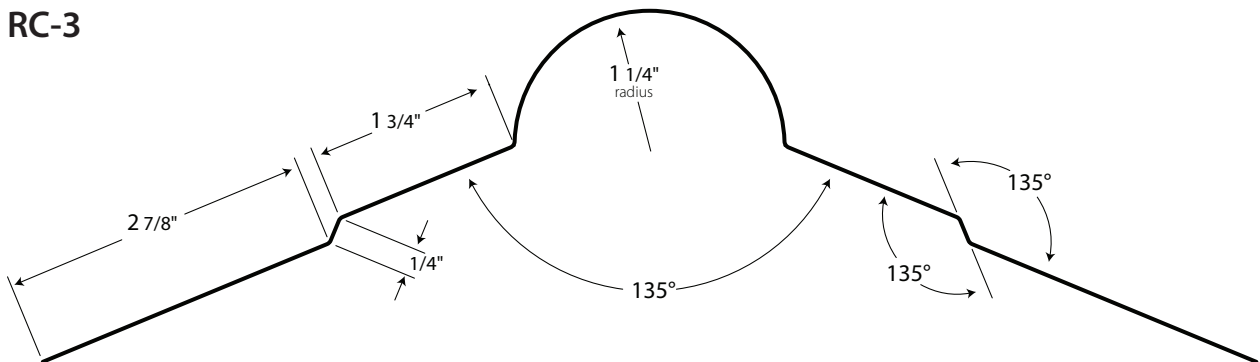

**Ridge Cap RC-8 (10' Lengths)**

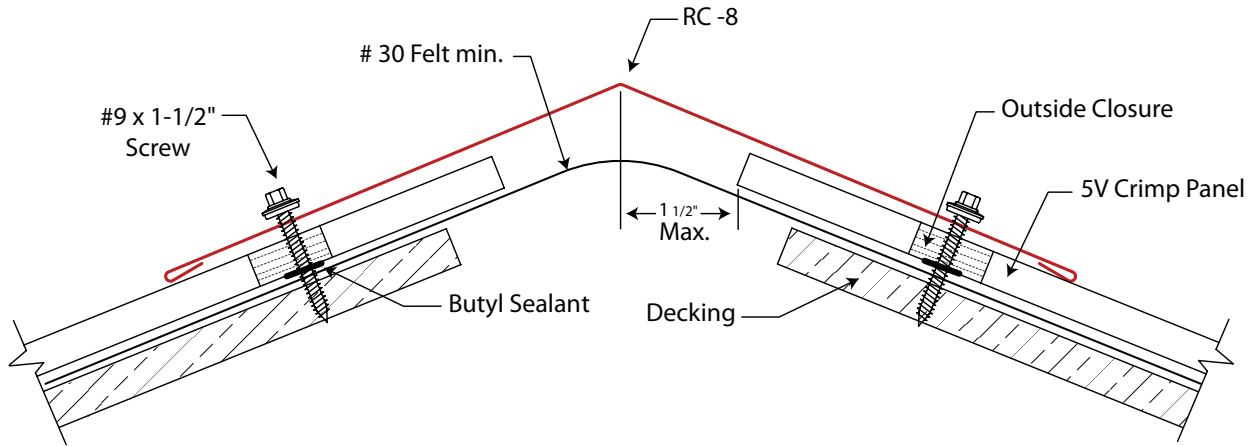

**Component Details**

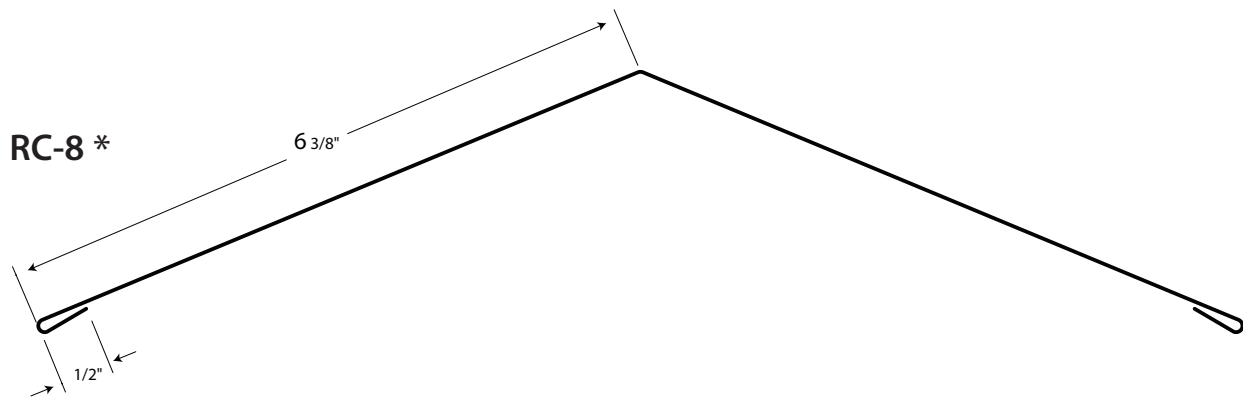

\* See page 28 for angle specification

**5V-Crimp**

## Vented Ridge with Venturi Vent

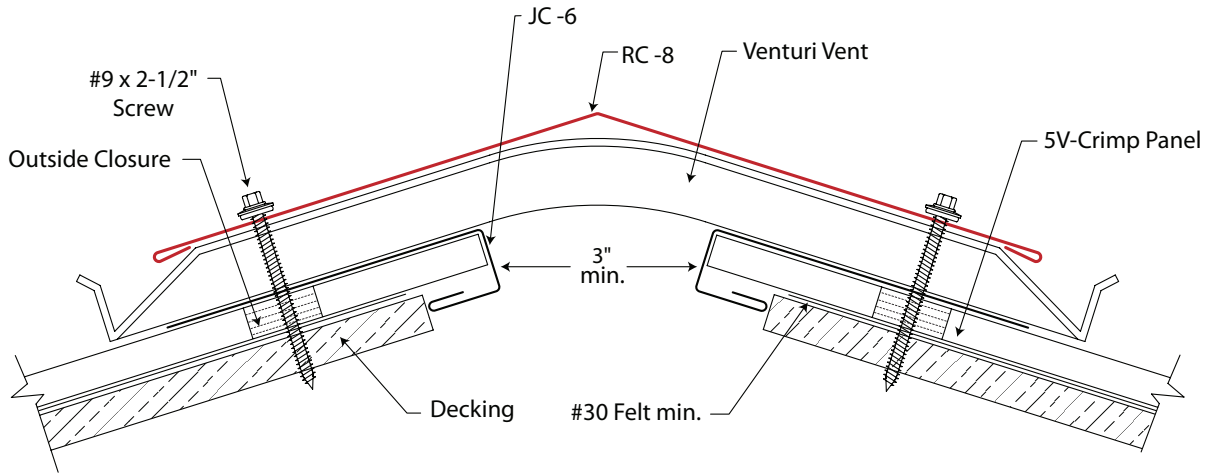

## Component Details

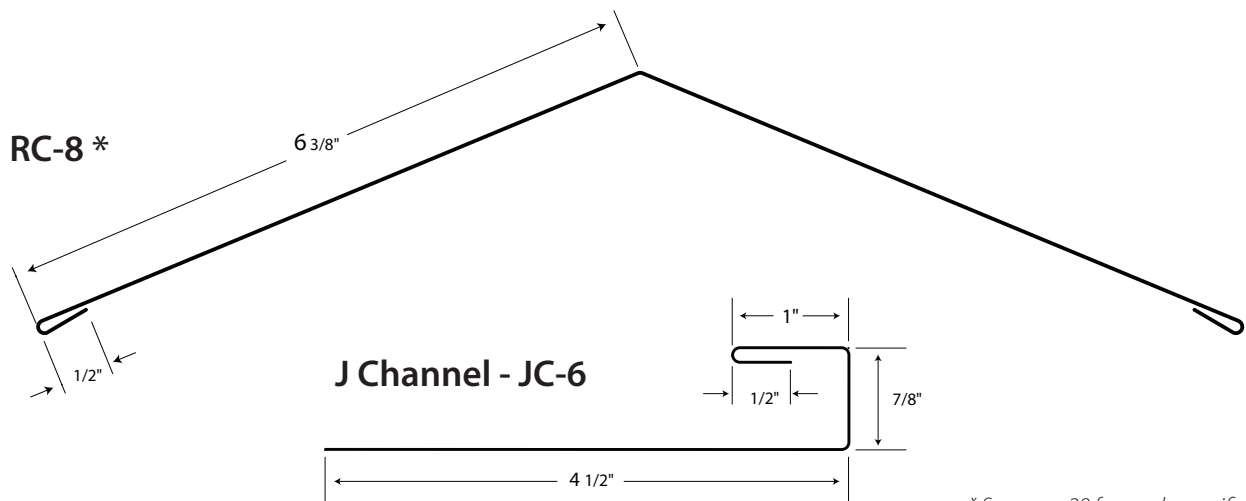

## Vented Ridge with Miami Dade Profile Vent

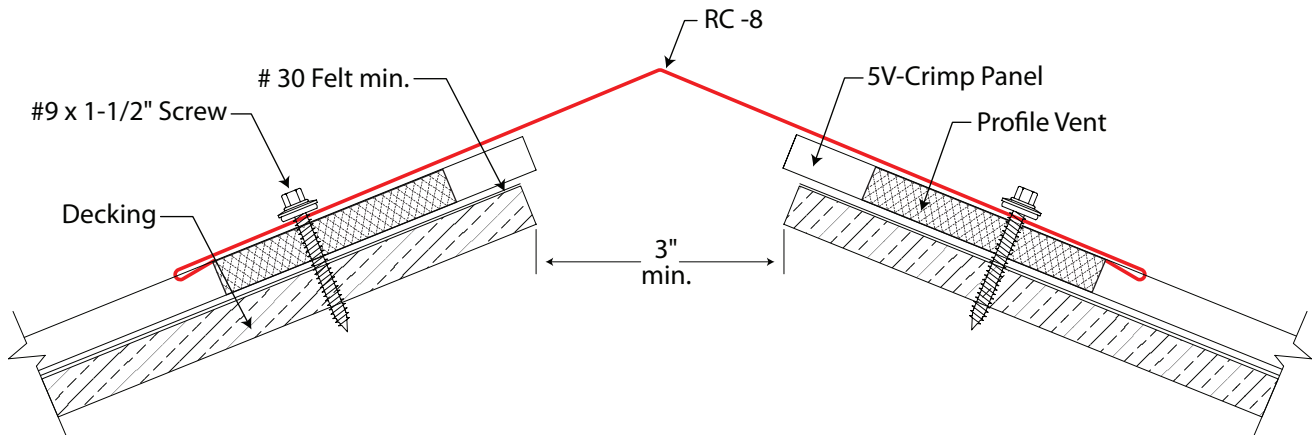

## Component Details

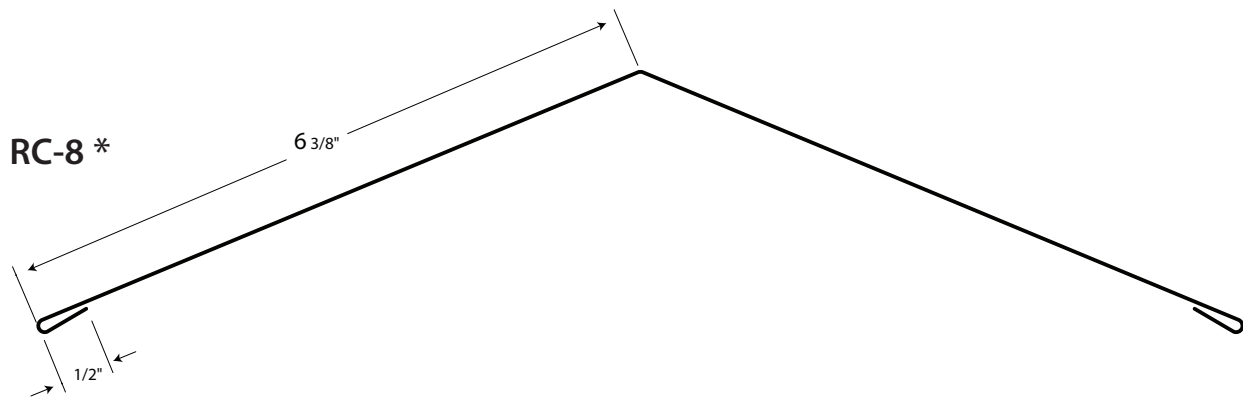

\* See page 28 for angle specification

**5V-Crimp**



# Pipe Boot

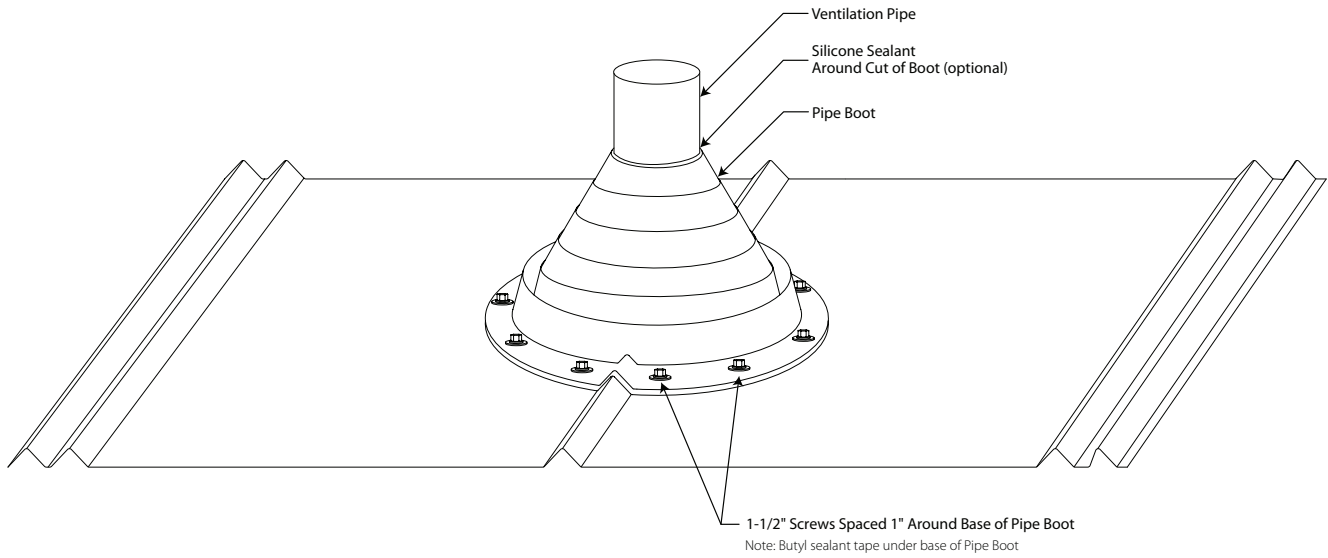

## Component Details

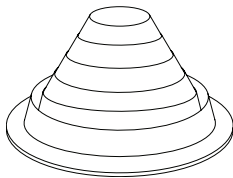

**Standard  
Pipe Boot**

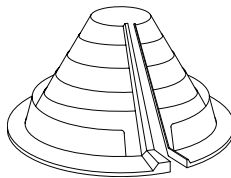

**Zipper  
Pipe Boot**

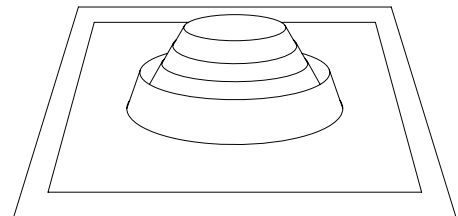

**Flashing  
Pipe Boot**

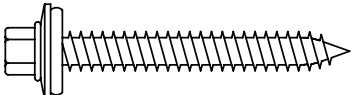
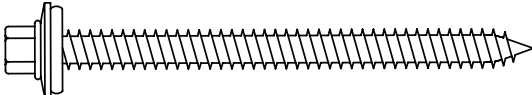
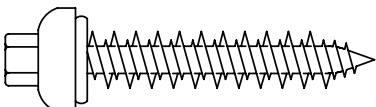
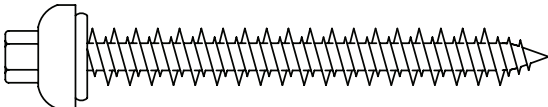
<b>Fastener Guide</b>			
<b>Fastener</b>	<b>Size</b>	<b>Finish</b>	<b>Application</b>
<b>Woodscrew</b> 	#9 - 1 1/2" #9 - 1 1/2"	Painted Mill Finish	Fastening galvanized based panels or trims to a wood substrate
<b>Woodscrew</b> 	#9 - 2 1/2" #9 - 2 1/2"	Painted Mill Finish	Fastening galvanized based panels or trims to a wood substrate
<b>Woodscrew</b> 	#9 - 1 1/2" #9 - 1 1/2"	Painted Mill Finish	Fastening galvalume or galvanized based panels or trims to a wood substrate
<b>Woodscrew</b> 	#9 - 2 1/2" #9 - 2 1/2"	Painted Mill Finish	Fastening galvalume or galvanized based panels or trims to a wood substrate

## Sealants and Accessories

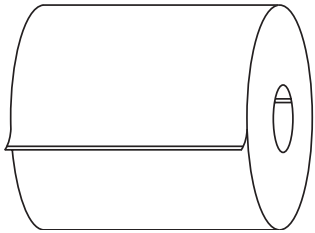

Hip Sealant Tape



Butyl Sealant Tape



Tube Sealant

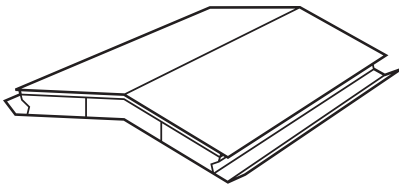

Venturi Vent

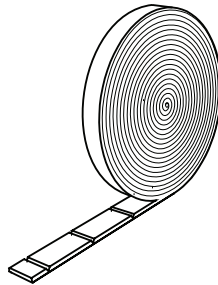

Profile Vent



Touch Up Paint

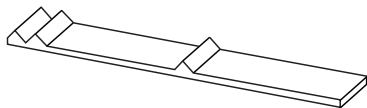

Inside  
Closure Strip

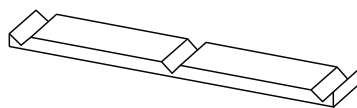

Outside  
Closure Strip

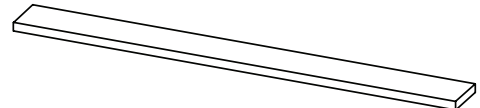

Universal  
Closure Strip

## Helpful Formulas

Rise and Run	Multiply Flat Area by	LF of Hips or Valleys per LF of Common Run	Decimal Fraction of a Foot	
			Inch	Fraction
2 in 12	1.041	1.424	1"	.083
3 in 12	1.031	1.436	2"	.167
4 in 12	1.054	1.453	3"	.250
5 in 12	1.083	1.474	4"	.333
6 in 12	1.118	1.500	5"	.417
7 in 12	1.158	1.530	6"	.500
8 in 12	1.202	1.564	7"	.583
9 in 12	1.250	1.600	8"	.667
10 in 12	1.302	1.641	9"	.750
11 in 12	1.357	1.685	10"	.833
12 in 12	1.413	1.732	11"	.917
			12"	1.00

## Roof Calculator

Height = 1/2 Span x Rise/Run (common run)

Height = Span x Pitch

Slope = Common Run x Factor

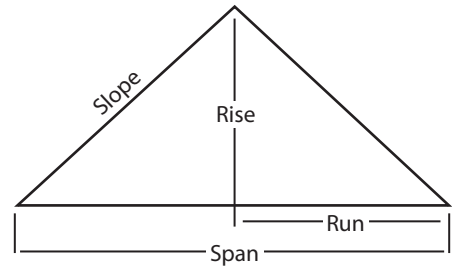

## Triangle

Area = 1/2 x B x H

$A = C^2 - B^2 = H$

$B = C^2 - A^2 = \text{Run}$

$C = A^2 + B^2 = \text{Slope}$

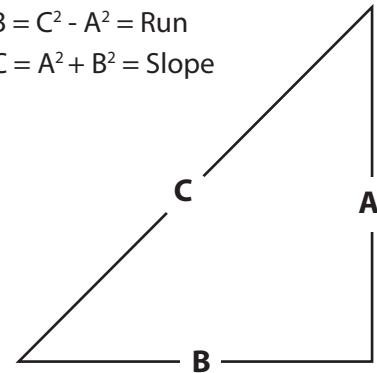

## Roof Slope Conversion Table with Roof Pitch Multiplier

Angle	Rise Run
45 Degrees	12/12
42.50 Degrees	11/12
39.75 Degrees	10/12
36.75 Degrees	9/12
33.75 Degrees	8/12
30.25 Degrees	7/12
26.50 Degrees	6/12
22.75 Degrees	5/12
18.50 Degrees	4/12
14.90 Degrees	3/12
9.50 Degrees	2/12
4.75 Degrees	1/12
0.0 Degrees	Flat

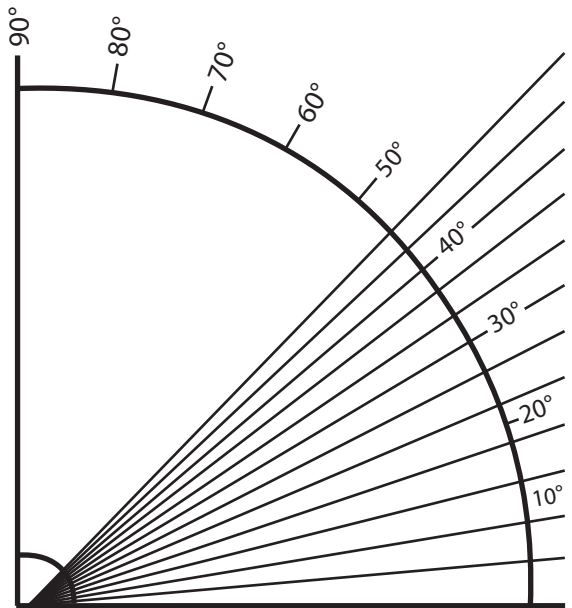

## Flashing Angle Specifier Chart

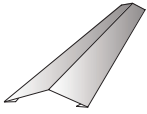
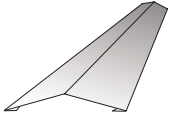
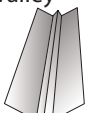
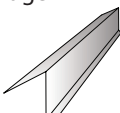
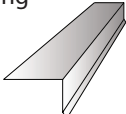
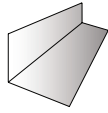
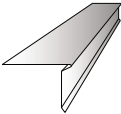
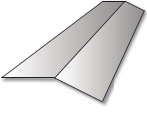
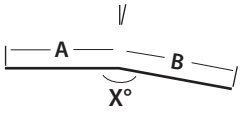
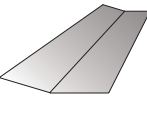
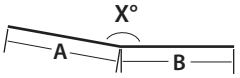
Profile/Flashing	*	1:12	2:12	3:12	4:12	5:12	6:12	7:12	8:12	9:12	10:12	11:12	12:12
Ridge Cap 	135°	170°	161°	152°	143°	135°	127°	120°	113°	106°	100°	95°	90°
Hip Cap 	148°	173°	166°	160°	154°	148°	143°	138°	133°	130°	126°	123°	120°
Pre-formed Valley 	136°	172°	162°	152°	144°	136°	128°	120°	114°	108°	104°	98°	90°
High Side Ridge 	67°	87°	81°	76°	71°	67°	63°	60°	56°	53°	50°	47°	45°
Eave Flashing 	90°	94°	99°	104°	108°	112°	116°	120°	123°	126°	128°	132°	135°
End Wall Flashing 	112°	94°	99°	104°	108°	112°	116°	120°	123°	126°	128°	132°	135°
Eave Drip 	90°	94°	99°	104°									
Gambrel Flashing 	 <p>To calculate the required pitch (X°), use the following equation:  <math>180^\circ - (A^\circ - B^\circ) = \text{Gambrel Flashing pitch } (X^\circ)</math></p>												
Transition Flashing 	 <p>To calculate the required pitch (X°), use the following equation:  <math>180^\circ - (A^\circ - B^\circ) = \text{Transition Flashing pitch } (X^\circ)</math></p>												

\* Default Pitch unless otherwise specified