



Best Barns USA Assembly Book

Revised September 19, 2016



the Meadowbrook-R

16' x 10'

Manufactured by Reynolds Building Systems, Inc.

205 Arlington Drive

Greenville, PA 16125

724-646-3775

This manual is copyrighted. Under the copyright laws, this manual may not be copied, in whole or in part, without consent from Reynolds Building Systems, Inc. © Copyright 2010

IMPORTANT INFORMATION ABOUT YOUR SHED KIT

This manual will show the assembly for the 16' x 10' Meadowbrook building kit. **If you received duplicate books, use the one with the latest revision date.**

The foundation size should measure 10'-0" deep by 15'-9" long. **Do Not** make the foundation larger than the building size. The siding should project beyond the foundation for water to expel properly from the sidewalls.

Read the instructions before starting the assembly of the building. If you have any questions about assembling the kit, call 800-245-1577. Business hours (8:00-5:00 ET) Monday thru Friday. After business hours call 724-866-HELP (4357) or email to help@barnkits.com.

The material that is included in our kit is listed on the back page. The optional floor package, if purchased, will be supplied by a local lumber supplier.

Our kit does not include the shingles, the quantity needed is listed under **Step 18**. The siding is primed. You will need to apply a finish coat using latex acrylic paint.

Some of the framing lumber was used in the shipping pallet. Unpack the material from the pallets, then unscrew the OSB sheathing, it will be used for the loft flooring. Unscrew the 2x4s from the shipping pallet. This material will be used for wall bracing and wall plates. The bit for the screws is packed in the hardware bag.

Stacking the boards, according to size, will make them easier to find when needed. Some boards have colored ends. All the 72" long 2x4s have black ends, stack these boards together.

Before you begin construction, be sure to study this assembly manual. Also, obtain a building permit and check all pertinent building code regulations.

Thank you for your purchase.

Bill & Linda Rinella, owners

The siding is made in 4x8 sheets with grooves cut into the face, the long edge is beveled so that the siding overlays where they butt.

To identify which edge we want you to use, we will refer to the edge as either the 'LAP' Edge or the Tongue Edge. Nail siding with 8d galv. nails, spaced 12" apart.

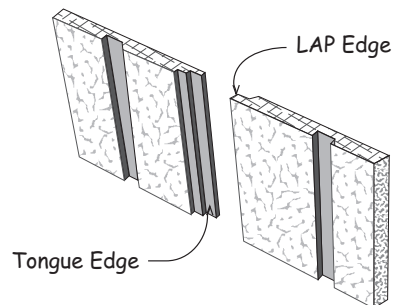

Tool List

- | | |
|--|---|
| <input type="checkbox"/> Hammer & Phillips Screwdriver | <input type="checkbox"/> Power Drill/Screwdriver |
| <input type="checkbox"/> Framing Square & Level | <input type="checkbox"/> Measuring Tape |
| <input type="checkbox"/> Hand or Circular Saw | <input type="checkbox"/> 2 - 8' Step Ladders |

Always wear safety glasses when cutting or nailing!

Constructing Details for Deluxe Floor System

Deluxe floors include 4x4 runners, standard floors do not

Foundation size is 10'-0" x 15'-9". Check local building codes in your area, the construction may have to change. For a concrete slab, install sill sealer as a moisture barrier between the concrete and the wall plates. Foam sill sealer can be purchased at home centers in rolls 3-1/2" or wider.

1. Cut joist headers to floor length. See Below.

Layout for 16" on center joist spacing. 'X' marks where floor joist will be placed.

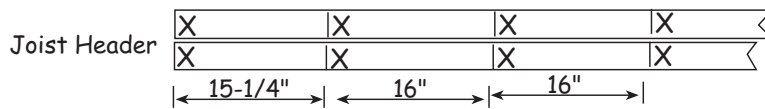

2. Cut 2x4-10' floor joist to 9' - 9". *Treated lumber may be thicker than 1-1/2". Take this into account when cutting the length of floor joists. Shorten joist measurements if necessary to obtain 10'-0" building width.*

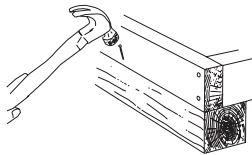
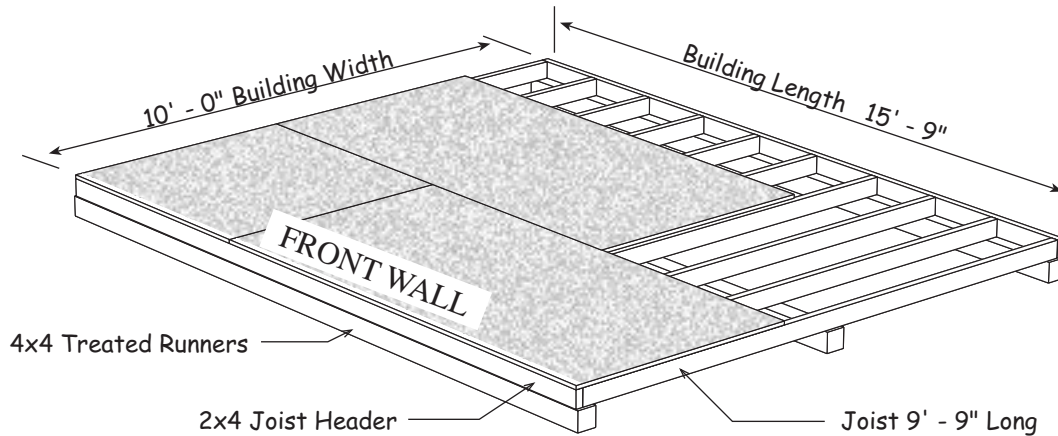

Nail the 2x4s to the 4x4 runners to keep the 2x4 frame from moving.

It is important that the floor be level and square. Before nailing the flooring, measure the floor diagonally (corner to corner). Then measure the opposite corners. These measurements will be the same if the floor is square.

Material Description	10' x 16' shed
2x4 Joist Headers	2 pcs. 16'
2x4 Floor Joist	13 pcs. 10'
4x4 Treated Runners	6 pcs. 8'
Flooring 5/8" or 3/4"	5 pcs. 4x8
Screw Floor Nails	2 lb. 8d
Galv. Box Nails	1 lb. 16d

Step 1 Assemble Trusses

1. Position (2) two truss halves together so that a 116-1/4" long 2x4 bottom cord may be placed between them.
2. Hold truss parts in place by temporarily screwing 2x4 blocks to the floor. There are short 2x4 blocks supplied in the kit for this purpose. Use 2-1/2" wood screws.
3. Secure the tops together with a 22-3/4" long ridge block and wood gusset. Nail the gusset with (16) sixteen 6d common nails. Space nails evenly.
4. Secure the truss bottom legs to the bottom cord with wood gussets. **Note:** You may have to spread the truss bottom to fit the bottom 2x4. Use 12 nails per gusset. Space nails evenly.
5. Assemble (5) five more trusses.
6. Turn trusses over and apply wood gussets to the opposite side.

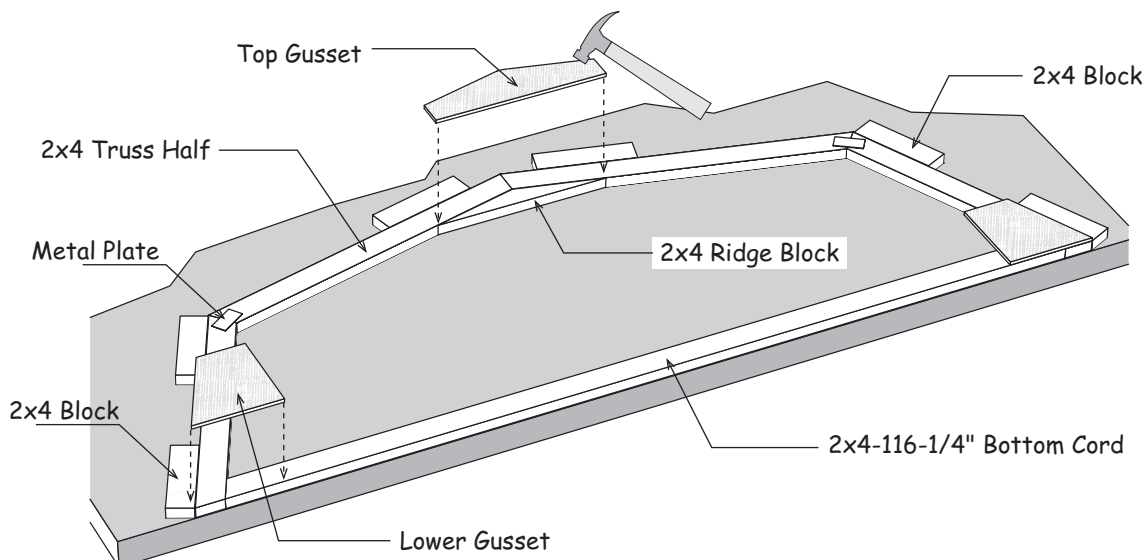

7. Assemble another truss without a bottom cord. Locate wood gussets with a 2x4 block attached to one side.
8. Attach this block/gusset to the bottom of each truss leg. Secure to leg with 6d common nails.
9. Turn truss over and apply gussets.

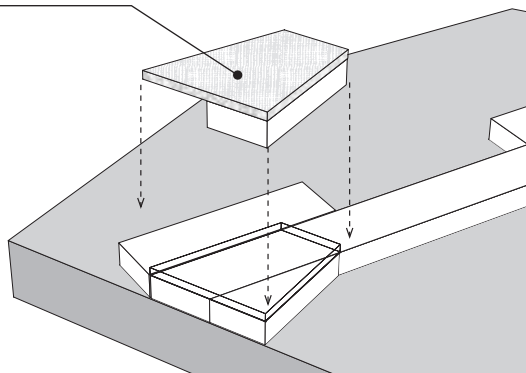

Do Not remove blocks from floor until **Step 2** is completed.

Step 2 Assemble Roof Gable Without Loft Doors

1. Place (2) two 47" long and (2) two 38" long 2x4 gable rafters in the truss jig. Secure at knee with 1"x4" drive-on plates. Position ridge block at peak. Locate (1) one 35-3/4" 2x4 center stud and secure to ridge block with 1"x4" metal plate. Nail gusset to ridge block and truss.
2. Install 116-1/4" bottom cord and nail gussets to bottom of truss.
3. Install (2) two 21-1/2" and (2) two 34-1/4" with angle cut on one end. Secure 2x4 gable studs to the truss with (9) nine 1"x4" metal plates at top and bottom.

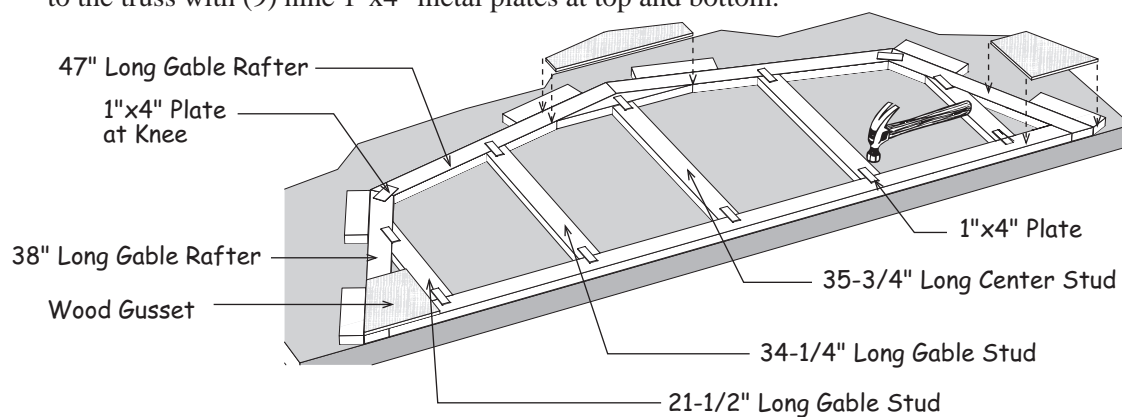

4. Screw (3) three 16" long 2x4 blocks flush with bottom of the 2x4 bottom cord. One on each end and one in the center. Use (2) two 2-1/2" screws.

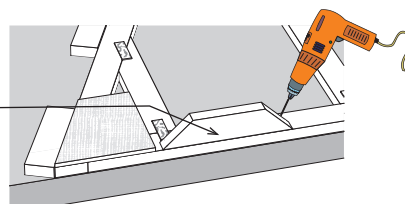

5. Turn the gable over. Locate pre-cut gable siding. Starting from left install the siding extending 3/4" below the bottom 2x4. Insure the siding does not extend above the top frame. Use 6d galv. nails spaced 12" apart.

 *Tip: To prevent gable studs from being knocked loose when nailing siding, lay 2x4 OSB sheathing, supplied in kit, under the studs.*

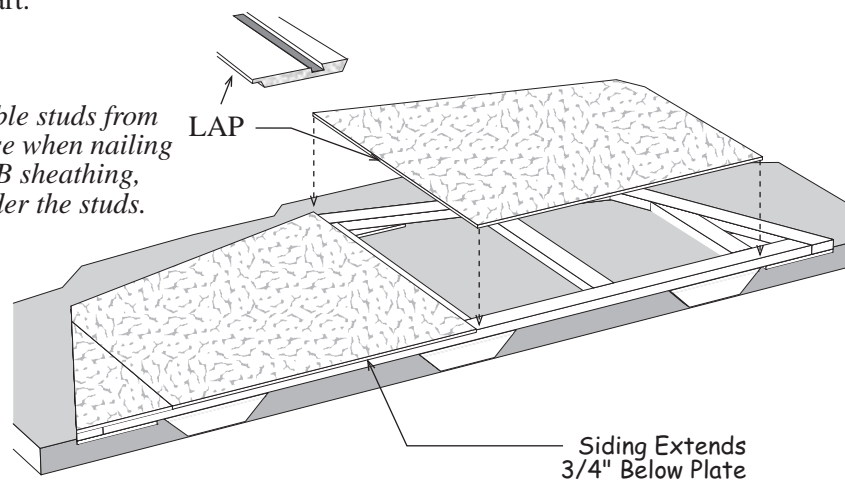

Step 3 Install Rear Gable Overhang & Trim

1. Apply 47" long 2x3 boards to the gable. These boards have a blue marking on one end. Install this end at the peak. Install boards flush with the top of the gable frame. Use 10d sinkers.
2. Install a 42-1/4" long 2x3 at the sides of the gable, flush with the frame. Board will extend below siding.

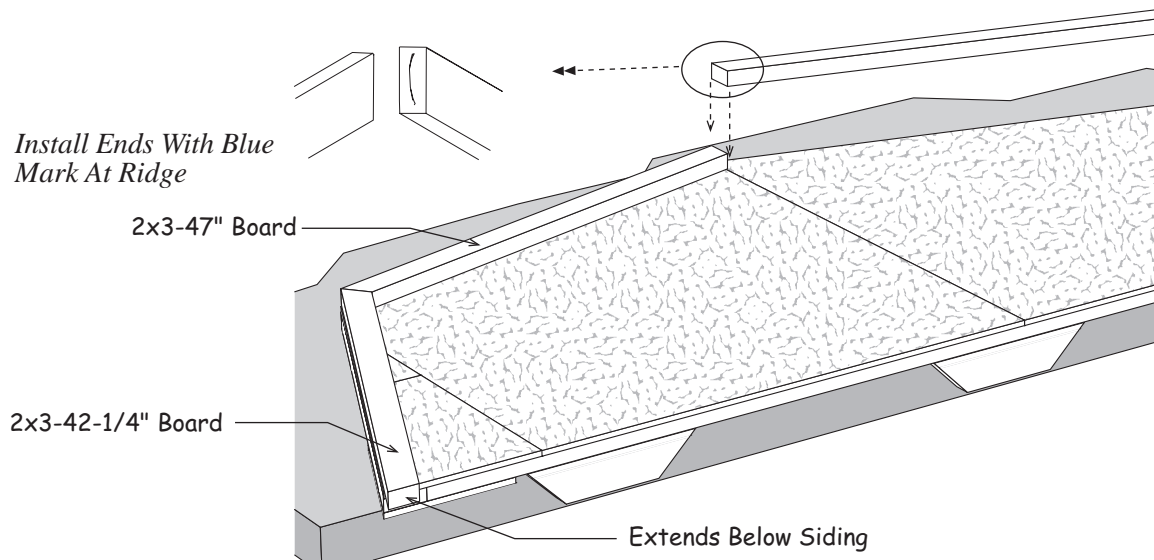

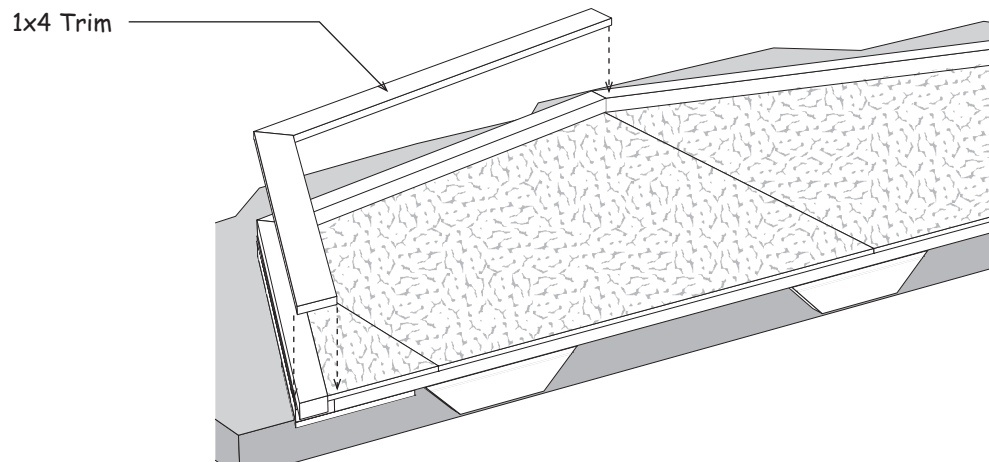

3. Apply 1x4 white pine trim to gable. Install a 47" long 1x4 at the top of the gable. These boards have a blue marking on one end. Install this end at the peak. Install the 1x4 gable trim extending 1/2" above the siding on the gable. When installed later, the roof sheathing will be flush with the top of the trim.
4. Install a 42-1/4" long 1x4 at the sides of the gable.

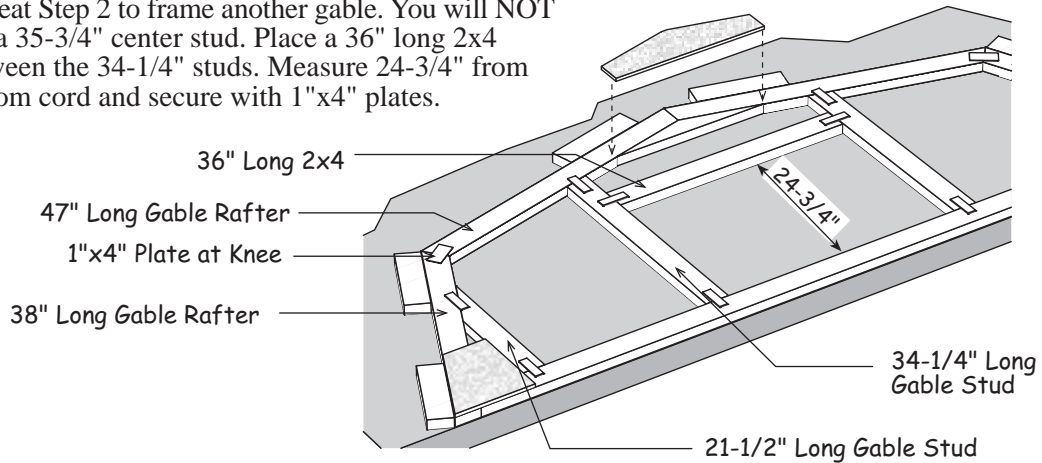

Step 4 Assemble Roof Gable With Loft Doors

1. Repeat Step 2 to frame another gable. You will NOT use a 35-3/4" center stud. Place a 36" long 2x4 between the 34-1/4" studs. Measure 24-3/4" from bottom cord and secure with 1"x4" plates.



 If you don't need loft access from the outside, attach loft door frames to the gable to create a decorative look and weather tight storage area.

2. Turn the gable over. Lay out the first (2) two pieces of siding on frame. **Important: Do not nail to frame.** Mark and cut so siding is flush with top and left side of opening. Cut to bottom of siding below gable plate. Nail first two pieces of siding to frame. Lay out next siding panel, do not nail, and repeat cut for right side door opening. Nail last two pieces of siding to frame.

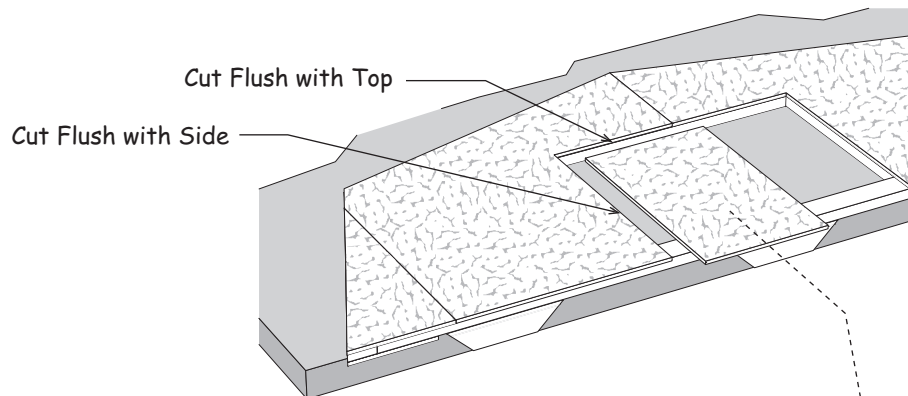

3. Assemble the loft doors. The loft door frames are temporarily held together with corrugated fasteners, this is the back side of the door frame. Place the doors on level surface, face side down. Cut the siding from above step to the size of the door frame. Secure the siding panel to the frame with 1" screws provided.

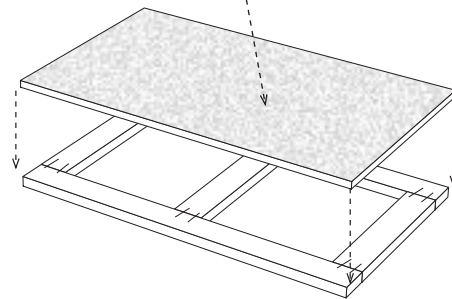

Step 5 Install Gable Trim & Loft Doors

1. Apply 47" long 2x3 boards to the gable. These boards have a blue marking on one end. Install this end at the peak. Install boards flush with the top of the gable frame.
2. Install a 42-1/4" long 2x3 at the sides of the gable, flush with the frame.
3. Install 29-1/4" long 1x3 trim boards on each side of the loft door opening. Install a 43" long trim board across the top.
4. Install loft doors using 4" hinges and 1-1/4" long hinge screws. The screws have a square head. The bit is packed with the screws. Install barrel bolts to the inside top of the doors to secure doors when closed. When door is closed mark where bolt will hit 2x4 gable frame. You will need to drill a 1/4" hole into the underside of the 2x4.

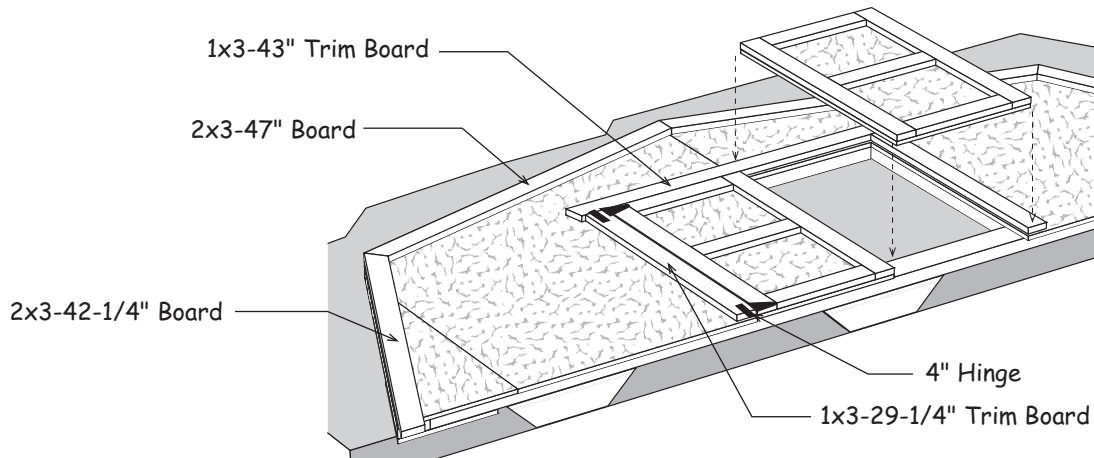

5. Apply 1x4 white pine trim to gable. Install a 47-1/2" long 1x4 at the top of the gable. These boards have a blue marking on one end. Install this end at the top. Install trim flush with the top of the gable frame. Use 8d galv. nails.
6. Install a 43" long 1x4 at the sides of the gable, flush with the frame.

Step 6 Cut 2x4 Wall Plates for Front Wall Assembly



Disassemble the shipping pallets. Save the OSB sheathing for the loft floor. Cut one of the 2x4 into (2) two 37-1/2" long 2x4s.

Position (2) two 80" long 2x4 boards, and the one cut above, together as shown below. Mark line and Indicate with 'X' marks, where the wall studs will be located.

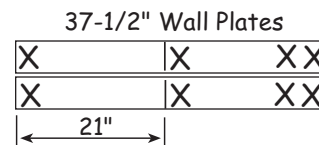
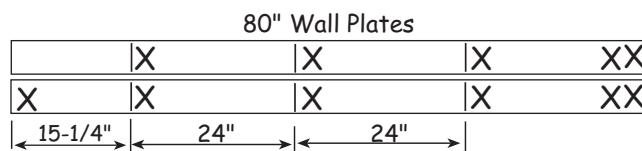

Step 7 Assemble Front Wall Panels

1. Cut (2) two 2x4-6' to a length of 69-1/2".
2. Assemble a door header jack by nailing a 69-1/2" long 2x4 to a 72" long 2x4. Use 10d sinkers.
3. Assemble another door jack.
4. Install 72" long wall studs between the wall plates cut in **Step 6**. Install 2x4 studs over the 'X' marks. Use (2) two 10d sinkers at the each end of stud.

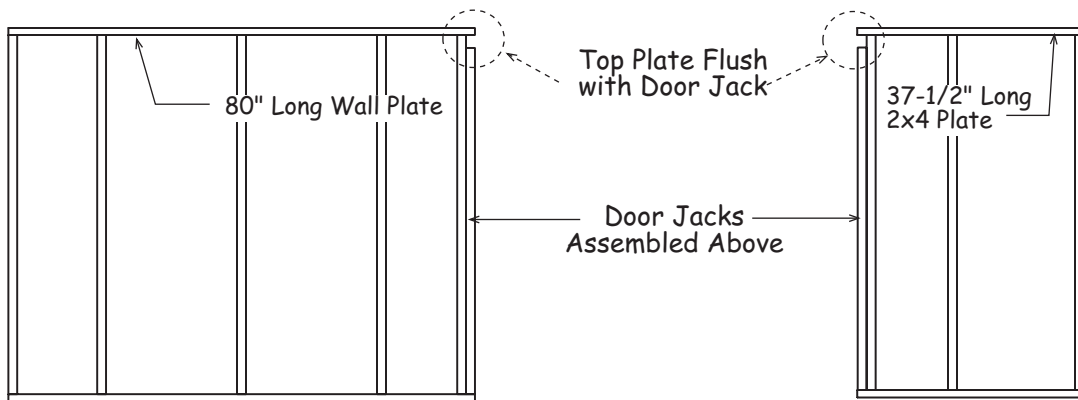
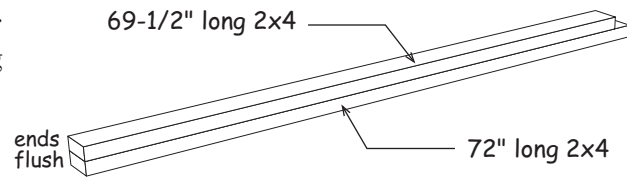

 To offset the doors to the left end of the wall, turn walls over before applying the siding.

5. Locate (2) two 16" wide x 77-1/4" long siding panels. Cut these panels to a length of 75-3/4".
6. Measuring from the 'tongue' edge, cut a full width x 75-3/4" panel to a width of 19-1/2". Save cut off to be used later. Install panel so the cut edge extends 3-1/2" beyond the end of the wall frame. Siding will be flush with the top of the 2x4 plate and extend 3/4" below the bottom plate. Use 8d galv. nails, 12" on center.
7. Install a full width x 75-3/4" siding panel.
8. Install the 16" panel, with the LAP edge, last.
9. Install a 70-1/2" long 2x6 as a tie plate across the top of the wall. Install the 2x6 flush with the siding

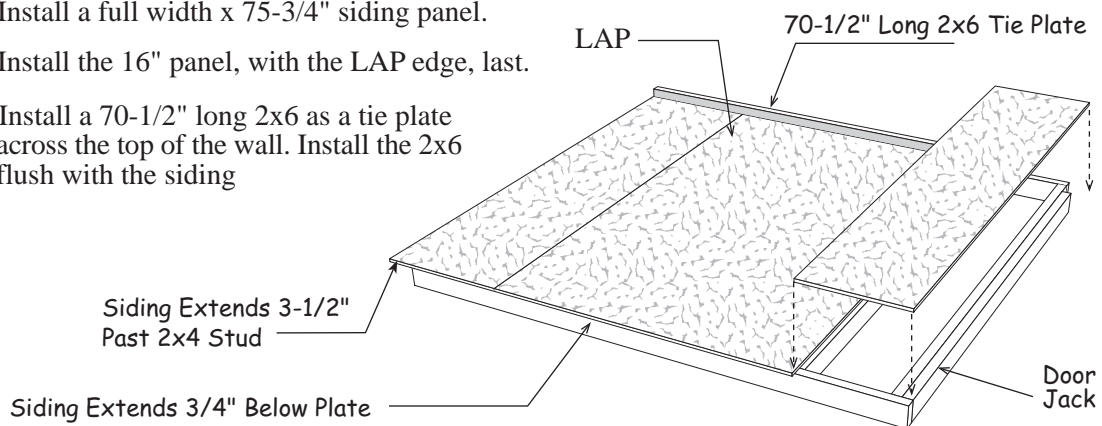

Step 7 Assemble Front Wall Panels Continued

10. Locate the 16" panel, with the tongue edge and install this panel with the cut edge flush with the 2x4 door jack. Install siding flush with the top of the 2x4 top plate.
11. Cut the leftover siding to a width of 25" and install as the last panel. The siding will extend 3-1/2" beyond the end of the wall frame.

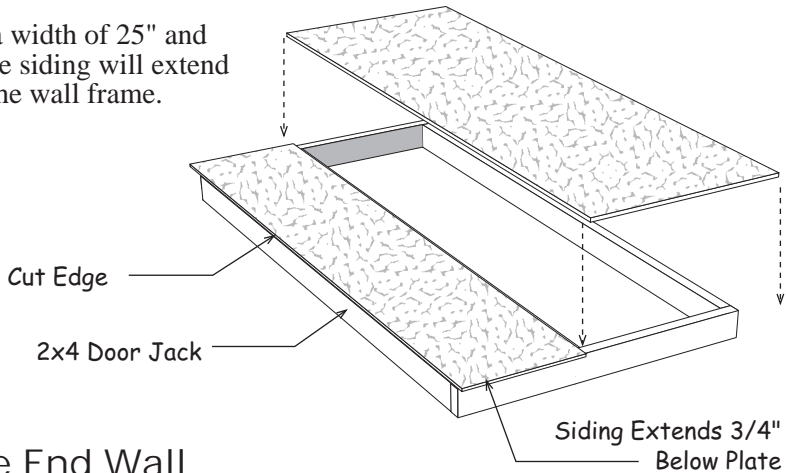

Step 8 Assemble End Wall

1. Position (2) two 2x4-10' boards together and indicate with 'X' marks, where the wall studs will be located.
2. Install 72" wall studs between the top and bottom plates.
3. Install (2) two 56-1/2" long 2x4 as tie plates over the top plate. The 2x4s will be 3-1/2" short of the end of the wall frame.

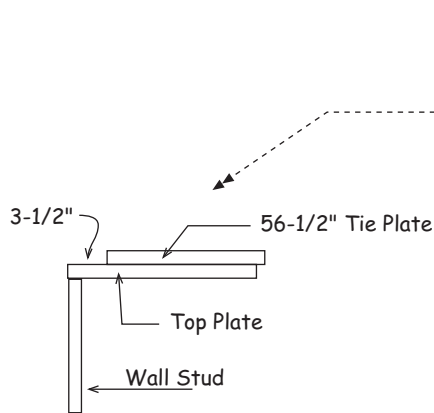
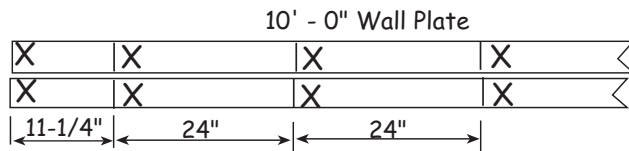

4. Square wall frame. Measure diagonally (corner to corner).

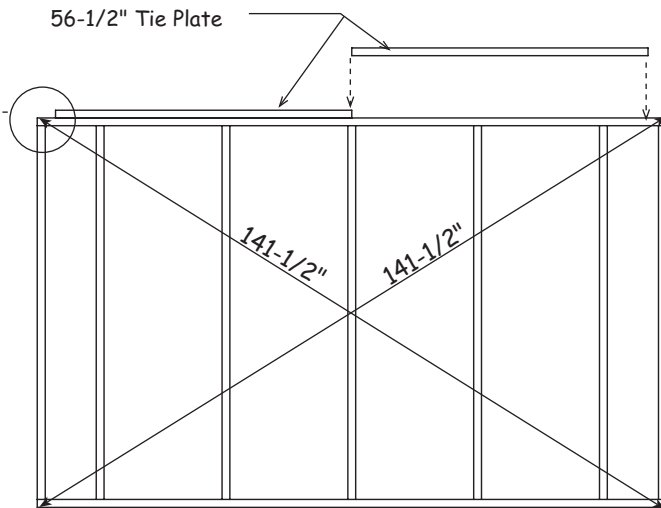

Step 9 Apply Siding to End Wall

1. Locate a 36-3/4" x 77-1/4" siding panel with the 'Tongue' edge. Install the siding panel on the left corner, with the 'cut edge' flush with the end of the wall and flush with the top of the 2x4 tie plate. The siding should extend below the bottom plate.
2. Install a 48-3/4" x 77-1/4" siding panel in the center of the wall frame.
3. Install a 36" x 77-1-4" panel with the 'LAP' edge last.

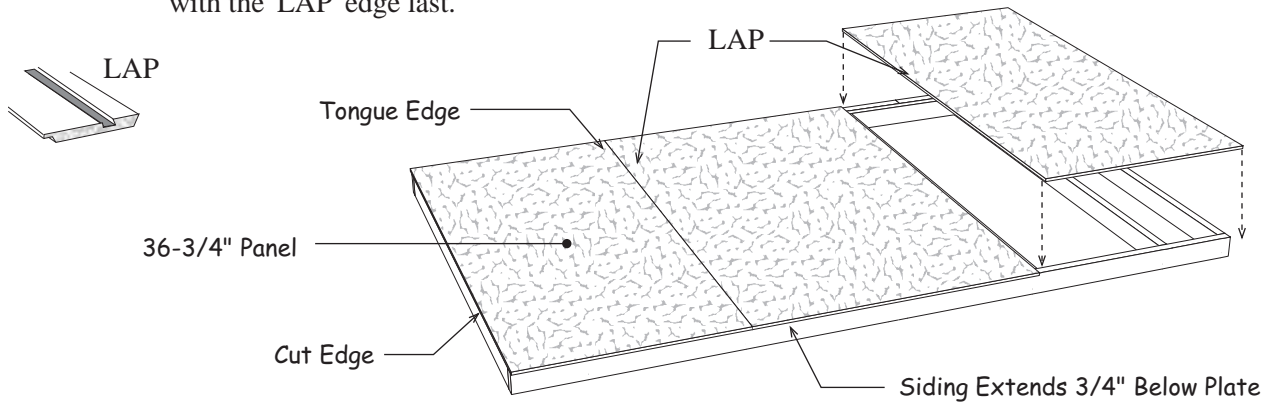

Step 10 Assemble Another End Wall

1. Repeat **Step 8** to assemble another end wall frame
2. Locate the 12-3/4" panel, with the 'tongue' edge. Install this siding panel with the cut edge flush with the end of the wall frame. Install siding flush with the top of the 2x4 wall plate.
3. Install (2) two full width siding panels in the center of the wall frame.
4. Install the 12" siding panel flush with the end of the wall frame.

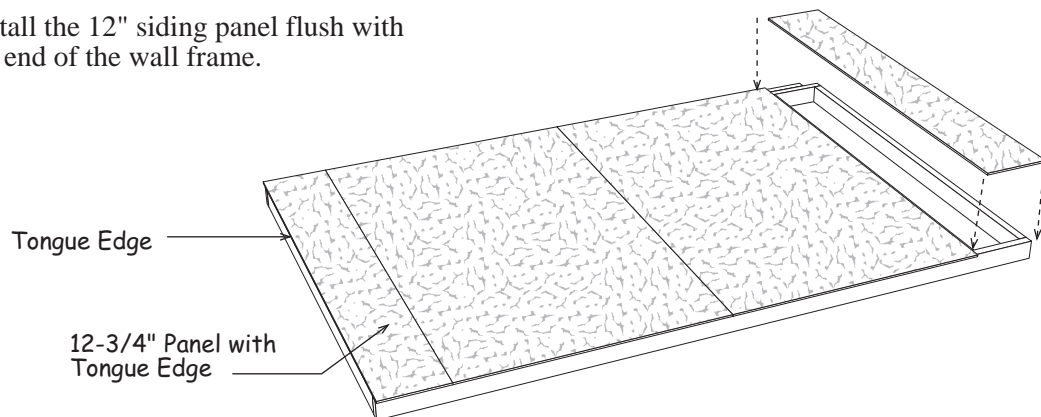

Step 11 Assemble Back Wall

1. Cut (2) two 68-1/2" long 2x4s to a length of 48". Position 68-1/2", 48", and 65-1/2" long 2x4 boards together and mark where the wall studs will be located. Mark the ends that will butt together with the letters 'A', 'B' and 'C'.

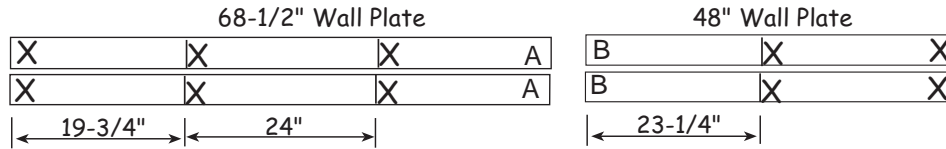

2. Install 72" wall studs between the top and bottom plates. Assemble frames and nail together with 10d sinkers.
3. Install a 48" and (2) two 70-1/2" long 2x6 boards as tie plates over the top plate. The 2x6s will extend 3-1/2" beyond the end of the wall frame.

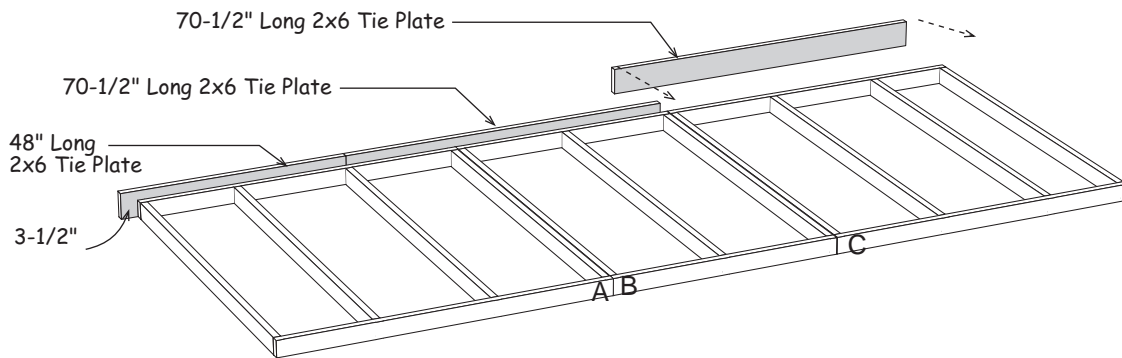
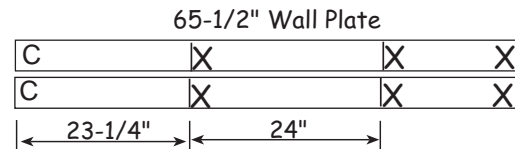

4. Square wall frame. Locate (4) four 75-3/4" long siding panels. Install the first siding panel with the 'LAP' edge extending 3-1/2" beyond the wall frame.
5. Install (2) two full width siding panels in the center.
6. Cut the last siding panel to extend 3-1/2" beyond the last wall stud. *Tip; it will be easier to handle this wall if you install the last siding panel after the walls are set.*

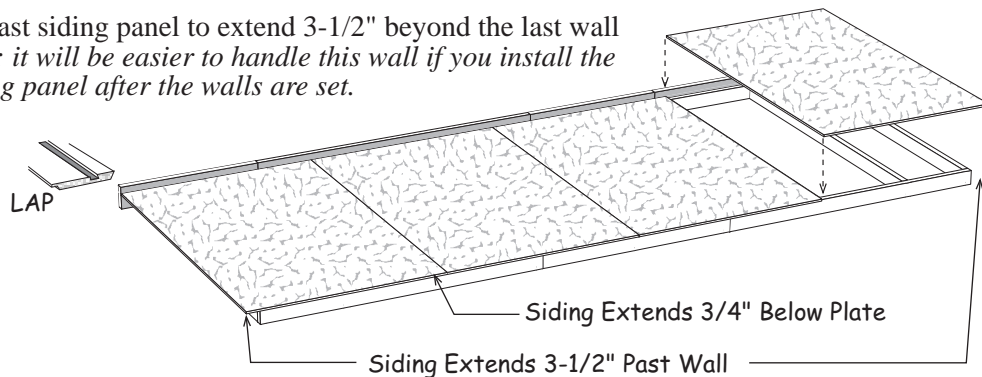

Step 12 Set Lower Walls

1. Secure wall panels together at the corners. Use (4) four 10d coated nails per corner. Nail wall panels to the floor. Nail through the bottom plate. Space 10d sinkers 24" apart.

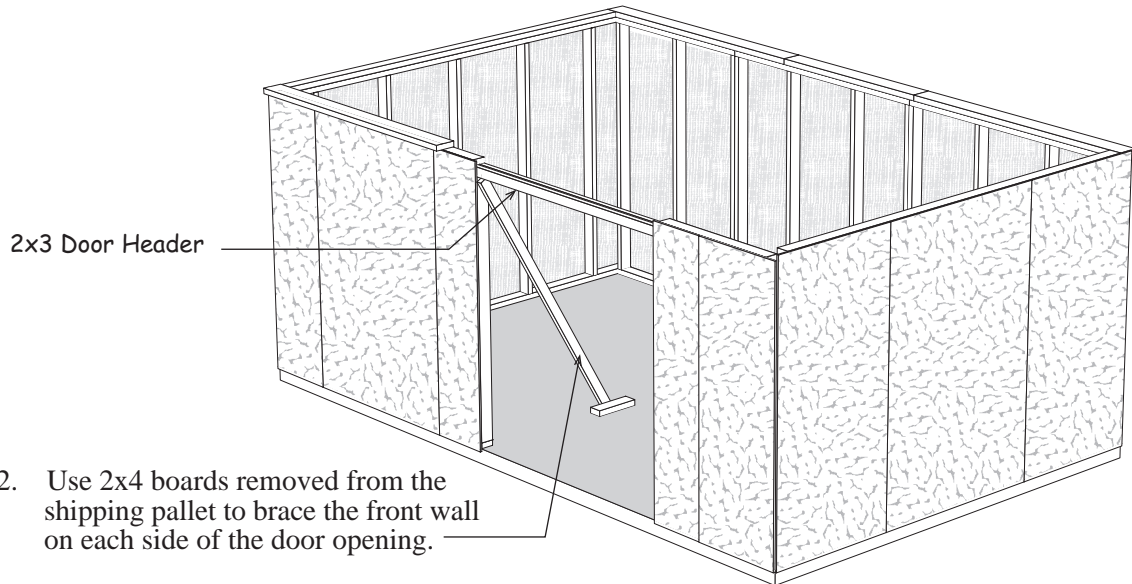

2. Use 2x4 boards removed from the shipping pallet to brace the front wall on each side of the door opening.
3. Install a 67-1/2" long 2x3 door header between the front wall panels. Secure header with 10d sinkers.
4. Cut a 65-1/2" long 2x4 to fit over the door header, between the front wall plates. Secure with 10d sinkers.
5. Install 70-1/2" and 48" long 2x6 over the 2x4 wall plates. Secure with 10d sinkers.

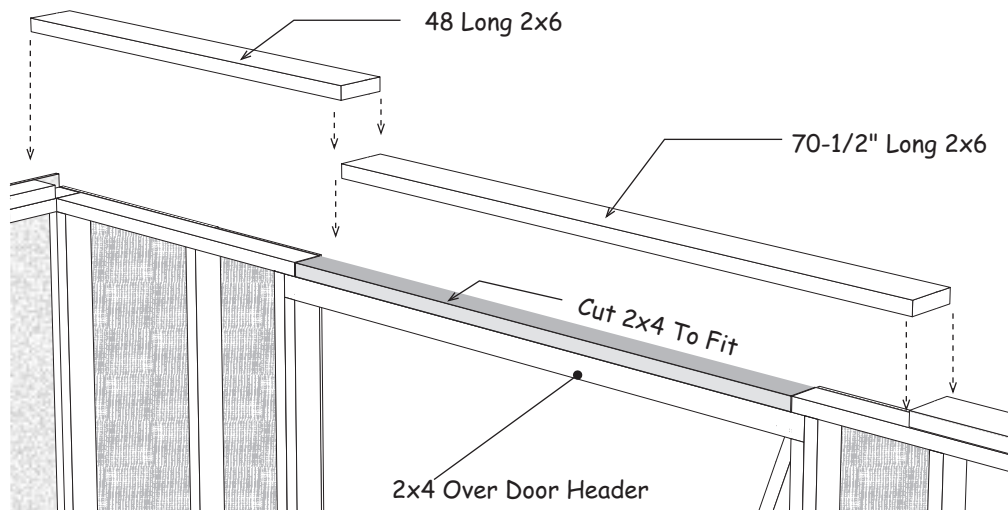

Step 13 Install Trim

1. Locate (2) two siding panels that are 32" wide x 6" in height. Cut these panels to a height of 4-1/2". Install these siding panels over the door header.
2. Install (2) two 1x4-72" boards along each side of the door opening, flush with the bottom edge of the siding. Tack these boards with a couple nails; you may want to move the trim later when you install the doors. Use 8d galv. nails.
3. Install a 1x3-72" board across the top of the side trim.

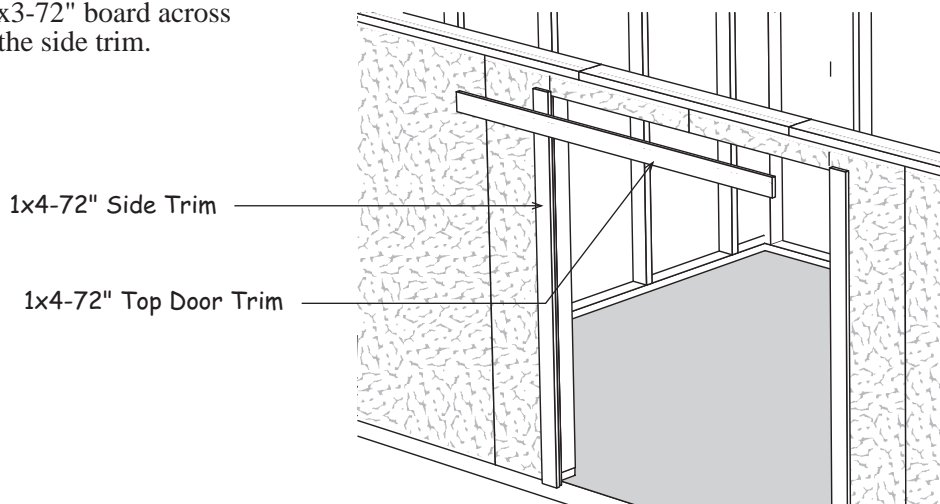

4. Install (2) two 1x3-62" long trim boards flush with the top of the front wall. Use 8d galv. nails.
5. Install 1x4-75 3/4" trim boards at the corners of the front and back. Install the trim flush with siding on the end wall.
6. Install 1x4x74-3/4" trim boards at the corners of the front wall.

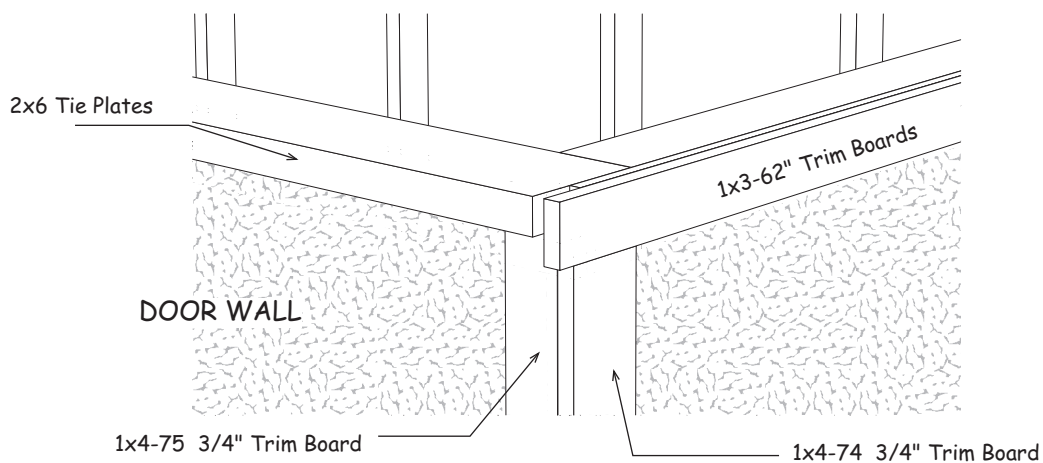

Step 14 Set Left Gable

Install the gable on the left end wall. The gable siding will extend over the 1x3 trim on the lower wall. **NOT behind the trim!** Secure gable to wall by nailing through the gable blocks with 10d sinkers. Nail siding along the 1x3 trim board with 6d galv. nails.

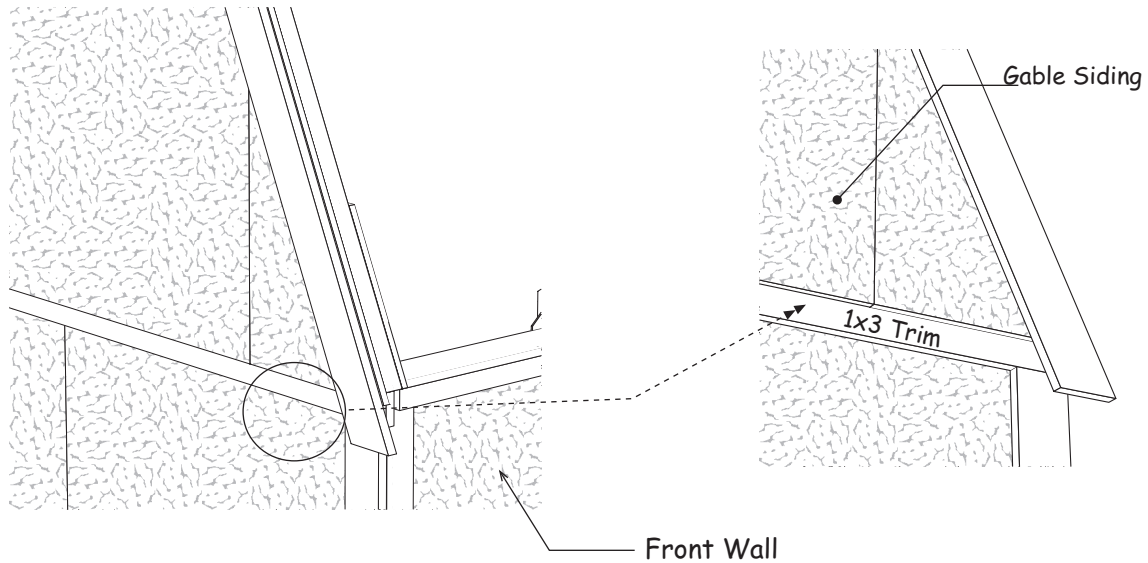

Step 15 Set Trusses

1. Layout the truss spacing on the front wall. Start at the left corner of the building. Measure from the inside face of the wood gusset when marking the location of the first truss. **See next page.**
2. Locate the truss hangers, there are left and right hangers. Select the right hangers.
3. Using 1-1/2" hanger nails, install the right hangers to the 2x6 tie plate. The top hanger flange should line up with the 'X' mark.

Important: When marking the back wall, use the left hangers and place the 'X' mark on the same side of the line so your trusses are parallel when they are installed.

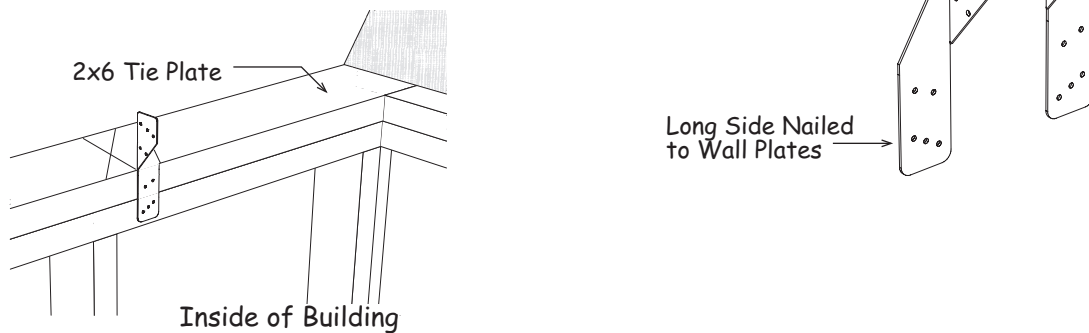

Step 16 Set Trusses Continued

4. Install the trusses over the 'X' marks. Install hanger to the opposite side of the trusses. Secure truss to metal hangers using 1-1/2" hanger nails.

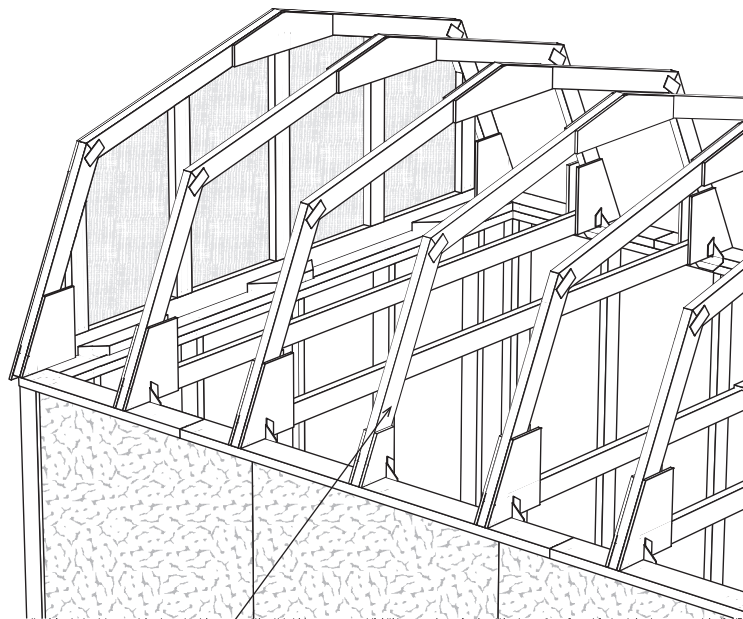
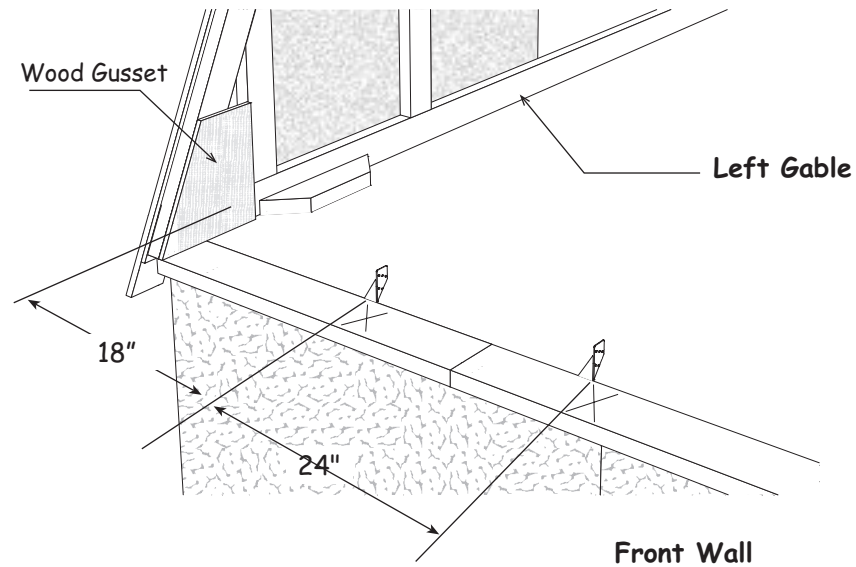

 Note: The center truss will not have a bottom cord.

Step 17 Install Loft Floor

1. Install a 4' x 4' OSB flooring panel between the siding on the rear gable and the center of the 2nd truss. Notch the panel around the studs on the gable and cut the width to fit on the center of the 2x4 truss bottom. Note: Some OSB panels may be attached to the shipping pallet. Secure floor with 7d sinkers.
2. Cut and install 2' x 4' OSB panels on each side of the center panel.

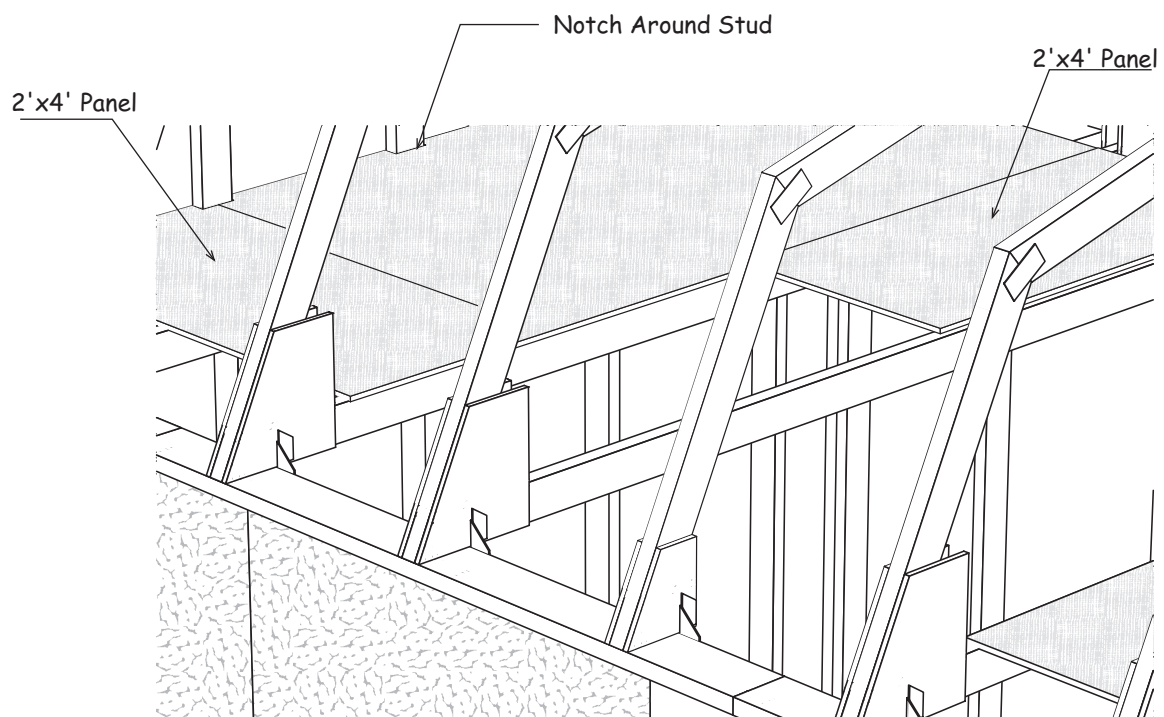

3. Install (2) two 2'x4' pieces as the 2nd row of flooring.
4. Install OSB flooring at the front of the building.

Step 18 Install Roof Sheathing

Install roof sheathing on the steep side of the roof. Use a straight edge to align the top of the sheathing with the top of the truss. See Detail 'B'. Make sure the trusses are plumb and the roof sheathing meets the center of the truss. Use 7d sinkers spaced 12" apart.

Install first sheet flush with back gable trim. Work back to front. The top roof sheathing will not extend to the ridge. This will allow an opening for air ventilation when you install a ridge vent.

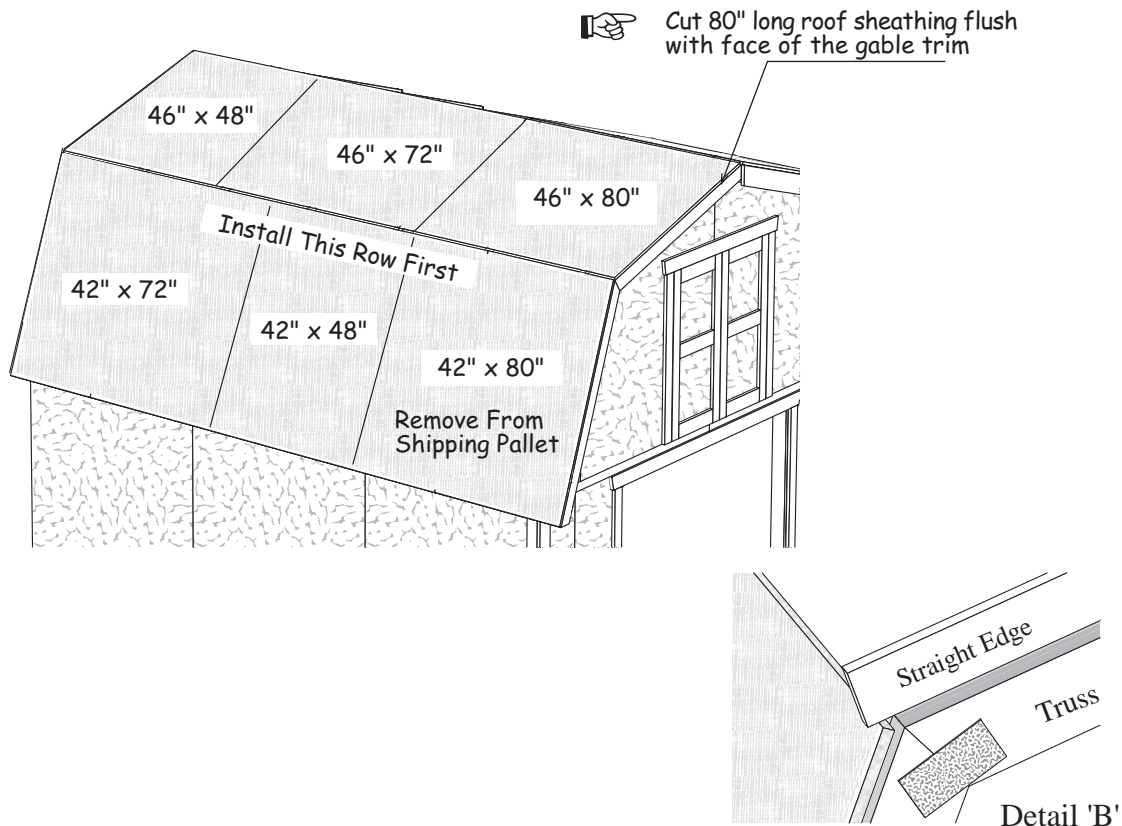

Install Shingles - not included in kit

1. Install felt paper and metal roof edge the perimeter of the building.
2. Install shingles according to the instructions on the wrapper. If you need more detailed instructions on installing shingles, there are good publications at book stores or newsstands.

Roof Shingles	10 bdl.
Roof 'drip' Edge	7 pcs.

Building Tip: Install ridge vent in lieu of shingles caps. Ridge vent provides ideal ventilation, preventing heat or moisture from damaging your building or its contents.

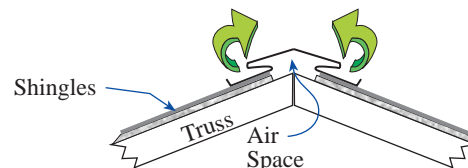

Step 19 Install Doors & Hardware

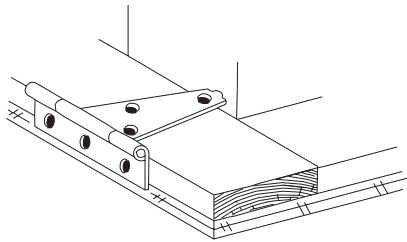

1. Lay the left door with the trim facing up. The siding on the left door extends past the door trim. See detail below.
2. Install 5" hinges to the left side of the door frame. To position the hinge properly, hold the rectangular plate against the frame. Use 1-3/4" black screws.
3. Install hinges to the right side of the other door.

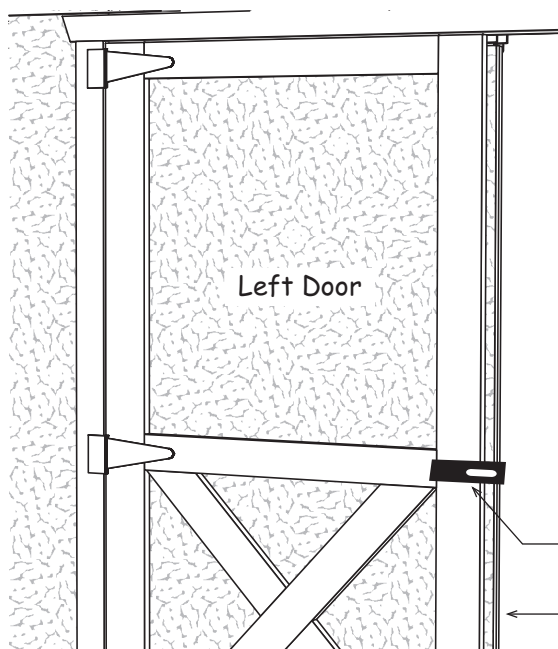

4. Before you fasten the hinges to the door trim, temporarily prop the doors in the opening. Leave a space at the top of the doors and between the doors and the side trim to allow room for the doors to expand when they absorb moisture.

If your door opening is out of square, the space around the doors will not be even. You can remove and reposition the side trim to make allowances for this. The side trim does not have to be flush with the frame of the door opening. You can move the trim in or out to make the door spacing equal.

5. Install hinges to trim with 2" screws.

Barrel Bolt on the back of left door

6. Install a barrel bolt on the lower back of the door to secure this door in place when closed. You will need to drill a hole for the round shaft to drop into.
7. Install another barrel bolt at the top of the door.

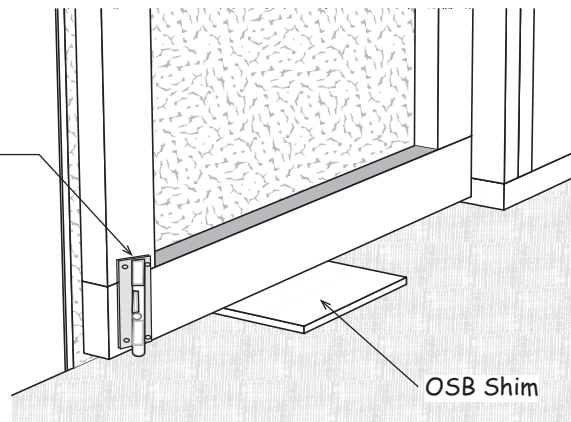

Meadowbrook and Woodville 10'x 16' Barn kit

Qty.	<i>2x4 & 2x6 Framing</i>		Size	Qty.	<i>White Pine Trim</i>		Size
4	Wall Plates		120 "	4	1x4 Gable Trim		47 1/2"
8	Truss - Bottom Cords		116 1/4"	4	1x4 Gable Trim		43 "
8	2x4 Boards Attached to Pallet		80 "	4	1x4 Corner Trim		75 3/4"
37	Wall Studs black ends		72 "	4	1x4 Corner Trim		74 3/4"
4	Wall Plates		68 1/2"	2	1x4 Door Trim		72 "
4	Wall Plates		65 1/2"	1	1x3 Top Door Trim		72 "
4	Wall Plates		56 1/2"	4	1x3 Lower Wall Trim		62 "
4	Gable Framing		47 "	2	1x3 Loft Door Trim		29 "
4	Gable Framing		38 "	1	1x3 Loft Door Trim		42 3/4"
1	Gable Studs & Framing		36 "	Exterior Siding & Soffit			
1	Gable Studs & Framing		35 3/4"	3	48" x 77-1/4"	2	12" x 77-1/4"
4	Gable Studs & Framing		34 1/4"	2	36" x 77-1/4"	6	48" x 75-3/4"
4	Gable Studs & Framing		21 1/2"	2	16" x 77-1/4"	2	6" x 32-1/4"
9	Truss Ridge Blocks		22 3/4"	4	Siding for Roof Gables		48" x 48"
6	Gable Nailing Blocks		15 3/4"	4	Siding for Roof Gables		16" x 30"
2	2x6 Tie Plates for Sidewalls		48 "	2	Siding For Door Header		6" x 32-3/4"
4	2x6 Tie Plates for Sidewalls		70 1/2"	4	8" x 48" Front Soffit Panels (Woodville model)		
2x3 Framing				Hardware			
4	Gable Overhangs		47 "	3	lb. 10d Sinkers		
4	Gable Overhangs		42 1/4"	3	lb. 8d Galv.		28 Truss Hangers
2	Gable Blocks		6 1/4"	2	lb. 7d Sinkers		75 Hinge Screws
Pre-built Components				4	lb. 6d Common		1 Door Hasp
14	Pre-built Truss Halves			1	lb. 6d Galv.		2 4" Barrel Bolts
2	32" x 72" Pre-built Barn Doors			4	lb. Hanger Nails		2 6" Barrel Bolts
2	18" x 29" Loft Door Frames			4	4" Door Hinges		12 2-1/2" Screws
1	2x3 Door Header		67-1/2"	6	5" Door Hinges		36 1-1/4" Screws
Loft Floor & Roof Sheathing				26	1x4 Drive-on Plate		24 1-5/8" Screws
2	42" x 80"	2	42" x 72"	Miscellaneous Lumber			
2	46" x 80"	2	46" x 72"	16	Wood Truss Ridge Gussets		8" x 24"
2	48" x 48"	8	24" x 48"	28	Wood Bottom Truss Gussets		12" x 12"
2	42" x 48"	2	46" x 48"	2	Center Truss Blocks w/gusset		3-1/2"x7-1/2"