



OWNER'S MANUAL

INSTALLATION AND OPERATION

INSTRUCTIONS FOR:

PORTABLE SPRINKLER/BOOSTER PUMP

MODEL: 96110

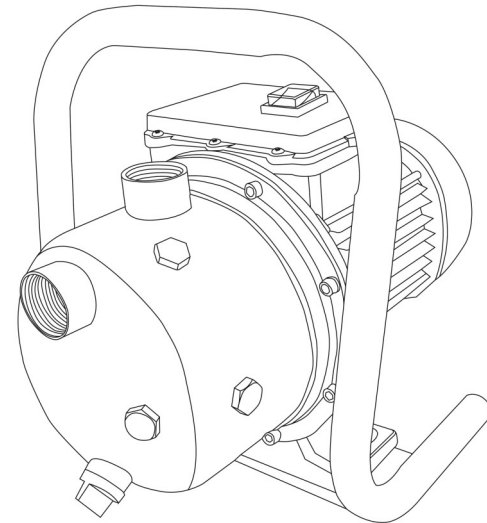

Safety Guidelines

Carefully read, understand and follow all safety instructions in this manual.

 This is the safety alert symbol. When you see this symbol, look for one of the following signal words.

⚠ DANGER Indicates a hazardous situation which, if not avoided, will result in death or serious injury.

⚠ CAUTION Indicates a hazardous situation which, if not avoided, could result in death or serious injury.

⚠ WARNING Indicates a hazardous situation which, if not avoided, could result in minor or moderate injury.

NOTICE Indicates important information, that if not followed, may cause damage to the equipment.

Safety Information

Read these warnings carefully. Know the application and limitations of this pump. Failure to follow these warnings could result in serious bodily injury and/or property damage.

⚠ DANGER This pump is not submersible. Do not submerge the motor in water or expose to water. Personal injury and/or death could result from electric shock.

⚠ DANGER Do not allow any part of the cord, or plug to sit in water or in damp locations. If using an extension cord, use only a UL listed, 3-wire, grounding type cord.

⚠ DANGER Do not use to pump flammable or explosive liquids such as gasoline, kerosene, fuel oil, etc. Personal injury and / or death could result. Do not use this pump in a flammable or explosive environment. This pump is intended to pump clear water only.

⚠ DANGER Do not touch this pump while standing in or walking on wet surfaces until all power is turned off. Do not touch an operating motor. Allow motor to cool before performing service. Failure to follow this warning could result in electric shock.

⚠ WARNING Do not run the pump dry. Running the pump dry can damage the internal parts of the pump or cause the pump to overheat which could result in personal injury. Running the pump dry will void the warranty.

⚠ WARNING This pump is equipped with a 3-wire, grounded cord and grounding type plug. Connect only to a properly grounded GFCI outlet. Never remove the grounding pin on the plug as this will make the pump unsafe to use and will also void the warranty.

NOTICE This pump is not designed to handle salt water, brine, laundry discharge or any other application which may contain caustic chemicals and/or foreign materials. Pump damage could occur if used in these applications and will void warranty.

LIMITED WARRANTY - SPRINKLER/BOOSTER PUMP:

Superior Pump warrants this product, to the original purchaser, for the initial residence in which it is installed (upon verification that it is installed correctly) to be free from defects in materials and or workmanship for a period of 1 YEAR from the date of purchase. During the time period and subject to the terms and conditions, Superior Pump will repair or replace to the original user or consumer any portion of this product which proves to be defective due to materials or workmanship. At all times Superior Pump shall have and possess the sole right and option to determine whether to repair or replace defective equipment, parts, or components. Superior Pump has the option to inspect any product returned under warranty to confirm that the warranty applies before repair or replacement under warranty is approved. This warranty sets forth Superior Pump sole obligation and purchaser's exclusive remedy for defective product. Return defective product to the place of purchase or postpaid to Superior Pump, Attn: Warranty Dept., 2301 Traffic Street N.E., Minneapolis, MN 55413 for warranty consideration.

WARRANTY PERIOD - PRODUCTS:

If, within the duration of product use by the original user, this product proves to be defective due to materials or workmanship, the product shall be repaired or replaced at Superior Pump option, subject to the terms and conditions set forth in this warranty statement. Proof of purchase is required for warranty consideration. In the absence of suitable proof of the purchase date, the effective period of this warranty is 12 months from the product's date of manufacture.

LABOR, ETC. COSTS:

Superior Pump shall IN NO EVENT be responsible or liable for the cost of field labor or other charges incurred by any customer in removing and/or affixing any product, part, or component thereof.

PRODUCT IMPROVEMENTS:

Superior Pump reserves the right to change or improve its products or any portions thereof without being obligated to provide such a change or improvement for units sold and/or shipped prior to such change or improvement.

GENERAL TERMS AND CONDITIONS:

This warranty shall not apply to damage due to acts of God, normal wear and tear, normal maintenance services and the parts used in connection with such service, lightning or conditions beyond the control of Superior Pump, nor shall it apply to products which, in the sole judgment of Superior Pump, have been subject to negligence, abuse, accident, misapplication, tampering, alteration; nor due to improper installation, operation, maintenance or storage; nor to excess of recommended maximums as set forth in the instructions. Warranty will be VOID if any of the following conditions are found:

1. Product is used for purposes other than those for which it was designed and manufactured
2. Product not installed in accordance with applicable codes, ordinances, and good trade practices
3. Product connected to voltage other than indicated on nameplate
4. Pump exposed to but not limited to the following: sand, gravel, cement, grease, plaster, mud, tar, oil, gasoline, solvents or other abrasive or corrosive substances
5. Pump has been used for pumping liquids above 120°F
6. Pump allowed to operate dry (liquid supply cut off)

DISCLAIMER:

Any oral statements about the product made by the seller, Superior Pump, the representatives, or any other parties do not constitute warranties, shall not be relied upon by the user, and are not part of the contract for sale. Seller's and Superior Pump only obligation, and buyer's only remedy, shall be the replacement and/or repair by Superior Pump of the product as described above. NEITHER SELLER NOR SUPERIOR PUMP SHALL BE LIABLE FOR ANY INJURY, LOSS OR DAMAGE, DIRECT, INCIDENTAL OR CONSEQUENTIAL (INCLUDING, BUT NOT LIMITED TO, INCIDENTAL OR CONSEQUENTIAL DAMAGES FOR LOST PROFITS, LOST SALES, INJURY TO PERSON OR PROPERTY, OR ANY OTHER INCIDENTAL OR CONSEQUENTIAL LOSS), ARISING OUT OF THE USE OR THE INABILITY TO USE THE PRODUCT, AND THE USER AGREES THAT NO OTHER REMEDY SHALL BE AVAILABLE TO IT. Before using, the user shall determine the suitability of the product for his/her intended use, and user assumes all risk and liability whatsoever in connection therewith.

THE WARRANTY AND REMEDY DESCRIBED IN THIS LIMITED WARRANTY IS AN EXCLUSIVE WARRANTY AND REMEDY AND IS IN LIEU OF ANY OTHER WARRANTY OR REMEDY, EXPRESSED OR IMPLIED, WHICH OTHER WARRANTIES AND REMEDIES ARE HEREBY EXPRESSLY EXCLUDED, INCLUDING BUT NOT LIMITED TO ANY IMPLIED WARRANTY OF MERCHANTABILITY OR FITNESS FOR A PARTICULAR PURPOSE, TO THE EXTENT EITHER APPLIES TO A PRODUCT SHALL BE LIMITED IN DURATION TO THE PERIODS OF THE EXPRESSED WARRANTIES GIVEN ABOVE.

Some states and countries do not allow the exclusion or limitations on how long an implied warranty lasts or the exclusion or limitation of incidental or consequential damages, so the above exclusion or limitations may not apply to you. This warranty gives you specific legal rights, and you may also have other rights which vary from state to state.

Replacement Parts

Bolts M6-1.0 x 14mm

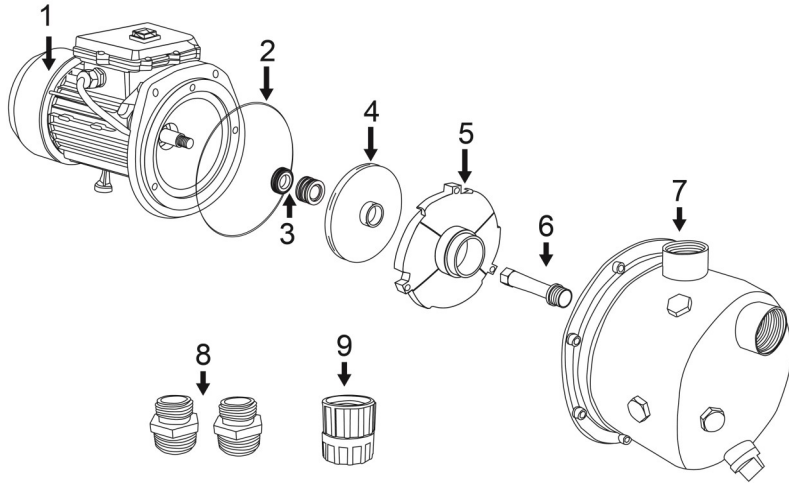

Ref#	Description	Part #
1	Motor	*
2	O-ring	99611
3	Shaft Seal	99604
4	Impeller	99609
5	Diffuser	99606
6	Venturi/Nozzle	99603
7	Pump Housing	99607
8	Male Garden hose adapters (qty 2)	99063
9	Female garden hose coupling	99248

*If motor fails, replace entire pump.

For parts assistance call 1-800-495-9278

Specifications

Circuit Requirements.....15 Amp

Motor Bearings.....Permanently Lubricated Ball Bearings

Models	HP	Volts	Amps	Hz	Suction/Discharge	Construction	Max. Liquid Temp.
96110	1	120	5.2	60	1"	Stainless Steel	120°F

Installation

⚠ DANGER Always disconnect the power source before attempting to install, service or perform maintenance. If the power source is out of sight, lock and tag in the off position to prevent unintended power application. Failure to do so could result in fatal electric shock. All wiring should be performed by a qualified electrician.

General Safety Information

1. Connect this pump to a grounded circuit equipped with a ground fault circuit interrupter (GFCI) device.
2. Before installing this product, have the electrical circuit checked by an electrician to ensure proper grounding.
3. Ensure the water source and piping are clear of sand, dirt, mud, scale & weeds. Debris will clog pump and void warranty.
4. Failure to protect pump and piping from freezing could cause severe damage and will void the warranty.
5. Do not run pump dry.

PUMPING FROM LAKES, STREAMS OR PONDS.

1. Locate pump as close as possible to the water source. Place pump on a solid and level foundation. Protect the pump from the elements, flooding and excessive moisture.
2. Long lengths of pipe or hose and use of many fittings will reduce pump flow. Use the smallest number of fittings and shortest possible length of pipe or hose as possible.
3. Be sure water is clear of debris such as sand, mud, rocks & weeds.
4. Connect inlet pipe or hose to pump. The inlet connection is designed for 1" NPT thread. Rigid pipe such as PVC or steel will work fine for inlet and outlet pipe. If using hose it must be the reinforced type as regular garden hose could collapse and result in pump failure.
5. A foot valve with strainer should be used to maintain prime during operation.
6. Seal all connections in the inlet hose. An air leak in the fittings, hose, pipe or connections will draw air even though no water leaks out. These inlet leaks will reduce pump performance and lead to pump failure.
7. Connect outlet pipe or hose to pump. The outlet connection is designed for 1" NPT thread. Rigid pipe such as PVC or garden hose may be used. An adapter to garden hose thread is included (Figure 1).

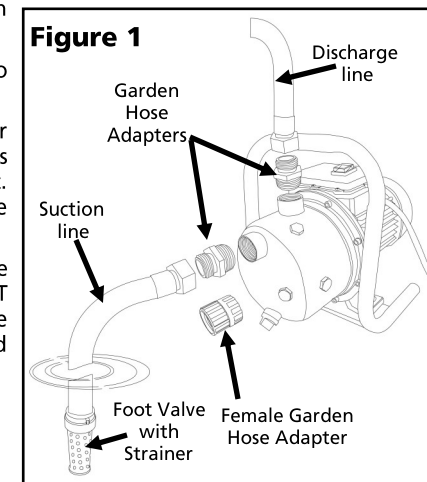

Installation - continued

⚠ CAUTION Do not run pump with outlet pipe or nozzle closed. The hose may burst from excessive pressure. Use only reinforced high-pressure hose or pipe for outlet pipe.

Boosting Water Pressure

1. Connect inlet pipe or hose to pump. A garden hose adapter is included.
2. Connect the other end of inlet line to water supply.
3. Connect outlet pipe or hose to pump.

Operation

⚠ CAUTION Never run the pump dry. Running pump without water will cause seal failure. Fill pump with water before starting.

1. Remove priming port on pump and fill with water. Reinstall priming port on pump. For boosting water pressure: Do not remove priming port. Turn on water supply.
2. Turn pump switch to the 'On' position. If the pump does not pump water within 30-60 seconds, turn off pump and refill with clean water. If the pump does not operate after repeated attempts, check the following:
 - Vertical distance of pump to water level must not be over 25 feet.
 - Suction line must be airtight.

Maintenance

1. Maintain adequate ventilation for the pump motor.
2. The motor bearings are permanently lubricated at the factory. Additional lubrication is not required.
3. Always protect pump and piping against freezing temperatures. If there is any danger of freezing, drain the system.
 - a. Disconnect suction and discharge lines from pump.
 - b. Remove plug from lower front face of pump.
 - c. Drain all piping below the frost line, or store piping indoors.
 - d. Store pump indoors.

Troubleshooting

PROBLEM	POSSIBLE CAUSES	HOW TO CORRECT
If the pump does not start or run	Pump is not plugged in, switch/breaker is off	Plug pump in or turn on switch/breaker
	Check for blown fuses or tripped circuit breakers or tripped GFCI outlets	Replace fuse, reset breaker, reset GFCI
	Wire connections are loose or wired incorrectly	Tighten connections or re-wire following wiring diagram on page 10
Motor runs hot and thermal overload protector turns pump off	Motor is not properly vented	Make sure there is adequate room for air to circulate around the pump
If the pump runs but moves little or no water	Loss of prime	Re-prime if necessary.
	Air lock in suction line	Make sure horizontal piping between the pump and the well pitches upward towards the pump. Otherwise an airlock may form
	Leak in suction line	Check all connections for leaks. Make sure all connections are air tight.
	Discharge or suction pipes may be clogged or corroded	Remove clog or replace pipes if necessary
	Vertical distance from the pump to the water is greater than 25 feet	Move pump closer to water source or shorten length of hose
	Intake screen/foot valve is obstructed	Clean or replace if necessary
	Foot valve or check valve is stuck in the closed position	Inspect, repair or replace if necessary
	Foot valve or check valve is installed backwards	Make sure valve is installed in the correct direction of flow
	Worn, damaged or clogged pump parts (Injector, impeller, diffuser, seal, etc.)	Inspect for wear, damage or clog and clean or replace if necessary
	Foot valve is buried in sand or mud	Raise above surface bottom
Water level source is too low	Move suction hose	
Pipes are frozen	Thaw pipes, heat pump house or bury pipes below frost line	