

# ***Shark***<sup>®</sup>

## **Navigator™ Lift-Away® DLX Upright Vacuum**

UV440

### **OWNER'S GUIDE**

---



# IMPORTANT SAFETY INSTRUCTIONS

## HOUSEHOLD USE ONLY

**To reduce the risk of electric shock, this vacuum cleaner has a polarized plug (one blade is wider than the other). As a safety feature, this plug will fit into a polarized outlet only one way. If the plug does not fit fully into the outlet, reverse the plug. If it still does not fit, contact a qualified electrician. DO NOT force into outlet or try to modify to fit.**

## **⚠ WARNING**

### **TO REDUCE THE RISK OF FIRE, ELECTRIC SHOCK OR INJURY:**

#### **GENERAL WARNINGS**

- Your vacuum cleaner may consist of a motorized nozzle, wand, hose, and/or vacuum pod. This device contains electrical connections, electrical wiring, and moving parts that potentially present risk to the user.
- Use only identical replacement parts.
- Carefully observe and follow the instructions provided below to avoid improper use of the appliance. **DO NOT** use the vacuum for any purpose other than those described in this manual.
- Before use, carefully inspect all parts for any damage. **DO NOT** use if any parts are damaged.
- The use of an extension cord is **NOT** recommended.
- This vacuum cleaner contains no serviceable parts.

#### **USE WARNINGS**

- **DO NOT** allow the appliance to be used by children. Close supervision is necessary when used near children. This is not a toy.
- Always turn off the vacuum cleaner before connecting or disconnecting any motorized nozzles or other accessories.
- **DO NOT** handle plug or vacuum cleaner with wet hands.
- **DO NOT** use without filters in place.

- Only use Shark® branded filters and accessories. Failure to do so will also void the warranty.
- **DO NOT** damage the power cord:
  - a) **DO NOT** pull or carry vacuum cleaner by the cord or use the cord as a handle.
  - b) **DO NOT** unplug by pulling on cord. Grasp the plug, not the cord.
  - c) **DO NOT** run the vacuum cleaner over the power cord, close a door on the cord, pull the cord around sharp corners, or leave the cord near heated surfaces.
- **DO NOT** put any objects into nozzle or accessory openings. **DO NOT** use with any opening blocked; keep free of dust, lint, hair, and anything that may reduce airflow.
- **DO NOT** use if nozzle or accessory airflow is restricted. If the air paths or the motorized floor nozzle become blocked, turn the vacuum cleaner off and unplug from electrical outlet. Remove all obstructions before you plug in and turn on the unit again.
- Keep nozzle and all vacuum openings away from hair, face, fingers, uncovered feet, or loose clothing.
- **DO NOT** use if vacuum cleaner is not working as it should, or has been dropped, damaged, left outdoors, or dropped into water.
- Use extra care when cleaning on stairs.

# SAVE THESE INSTRUCTIONS

## READ ALL INSTRUCTIONS BEFORE USE

- **DO NOT** leave the vacuum cleaner unattended while plugged in.
- When powered on, keep the vacuum cleaner moving over the carpet surface at all times to avoid damaging the carpet fibers.
- **DO NOT** place vacuum cleaner on unstable surfaces such as chairs or tables.
- Your Shark® vacuum may not be designed to stand up on its own. When taking a break from cleaning, you may need to lean it against furniture or a wall, or lay it flat on the floor. Using the vacuum for an application where the unit lacks stability may result in personal injury.
- **DO NOT** use to pick up:
  - a) Liquids
  - b) Large objects
  - c) Hard or sharp objects (glass, nails, screws, or coins)
  - d) Large quantities of dust (drywall dust, fireplace ash, or embers). **DO NOT** use as an attachment to power tools for dust collection.
  - e) Smoking or burning objects (hot coals, cigarette butts, or matches)
  - f) Flammable or combustible materials (lighter fluid, gasoline, or kerosene)
  - g) Toxic materials (chlorine bleach, ammonia, or drain cleaner)
- **DO NOT** use in the following areas:
  - a) Poorly lit areas
  - b) Wet or damp surfaces
  - c) Outdoor areas
  - d) Spaces that are enclosed and may contain explosive or toxic fumes or vapors (lighter fluid, gasoline, kerosene, paint, paint thinners, mothproofing substances, or flammable dust)
- Turn off all controls before plugging in or unplugging the vacuum.
- Unplug from electrical outlet when not in use and before any maintenance or cleaning.
- Hand wash with water only. Washing with cleaning chemicals could damage the unit.
- During cleaning or routine maintenance, **DO NOT** cut anything other than hair, fibers, or string wrapped around the brushroll.
- Allow all filters to air-dry completely before replacing in the vacuum to prevent liquid from being drawn into electric parts.
- Make sure the dust cup and all filters are in place after routine maintenance.
- If provided, secure the power cord around the two cord hooks during storage.

## ASSEMBLY

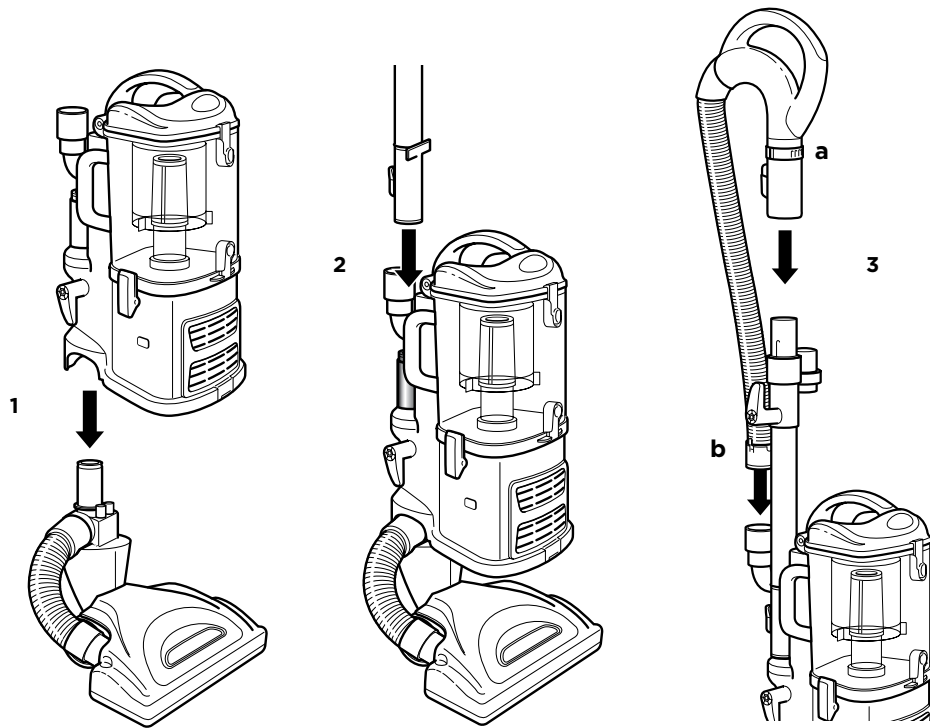

1. Place the **Floor Nozzle** on a level surface. Align the tube of the floor nozzle with the tube on the Lift-Away® Pod and slide the pod down until it clicks into place.
  2. Insert the end of the **Extension Wand** into the tube on the back of the Lift-Away® pod until it clicks into place.
  3. **a)** Insert the **Handle** into the top of the extension wand until it clicks into place.  
**b)** Insert the end of the **Stretch Hose** into the connector on the back of the Lift-Away® pod.
- For proper operation, ensure all parts are firmly clicked into place.

**NOTE:** There are a variety of accessories that are compatible with this vacuum series. The top flap of your box shows the select accessories that are included with your model. For additional accessories, visit [sharkaccessories.com](http://sharkaccessories.com)

## USING YOUR VACUUM

### SETTINGS

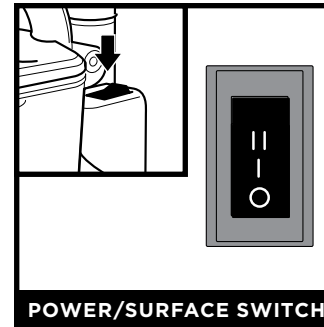

Press the **Power/Surface Switch** at the top of the pod.

Select surface setting:

**O Power Off**

**I Bare Floor**

For bare floors and small area rugs.

**II Carpet**

For carpets.

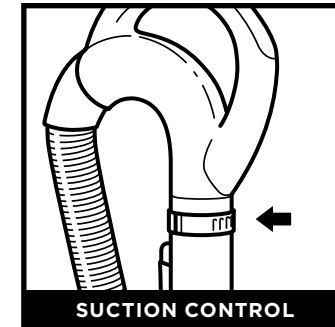

**Suction Control** offers variable suction based on your needs. Rotate counter-clockwise to reduce suction and increase maneuverability on carpets. Rotate clockwise to increase suction on bare floors.

### BRUSHROLL INDICATOR LIGHT

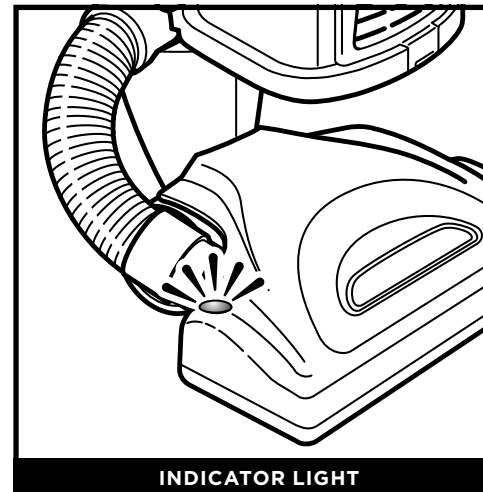

#### WHAT DOES THE BRUSHROLL INDICATOR LIGHT MEAN?

**Solid Green:** The brushroll is on and working as it should.

**Solid Red:** There is a jam in the brushroll area. Turn your vacuum off and remove the blockage.

**Flashing Red:** The vacuum is overheated. Turn the vacuum off and wait for it to cool down. See Troubleshooting section for more information.

**No Light:** The vacuum is off.

**NOTE:** For deep carpet cleaning per ASTM F608 (embedded dirt in carpets), use setting **II, Carpet**.

## WHOLE-HOME CLEANING

### CLEANING MODES

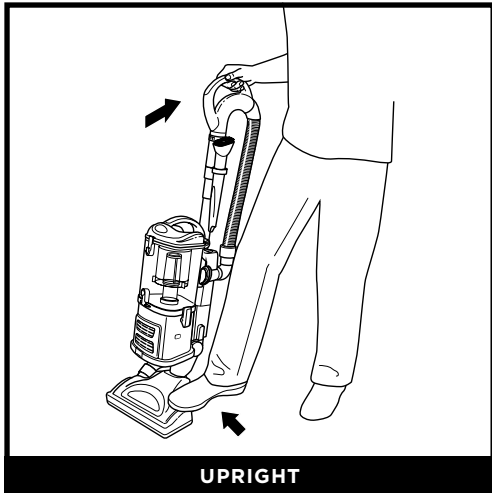

UPRIGHT

To engage brushroll, turn power on, then step on floor nozzle and tilt handle back.

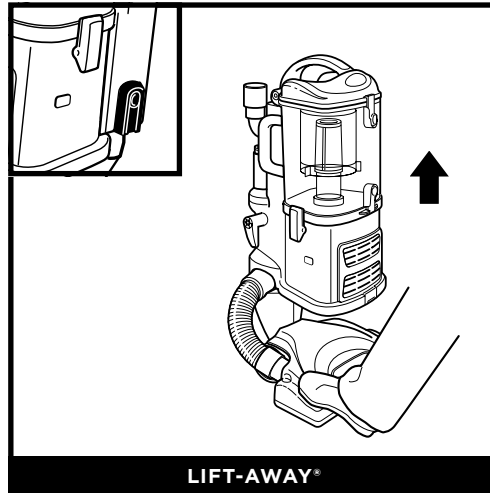

LIFT-AWAY®

Press the red **Release Button** on the side of the pod. Gently step on the nozzle and pull the pod up to detach it.

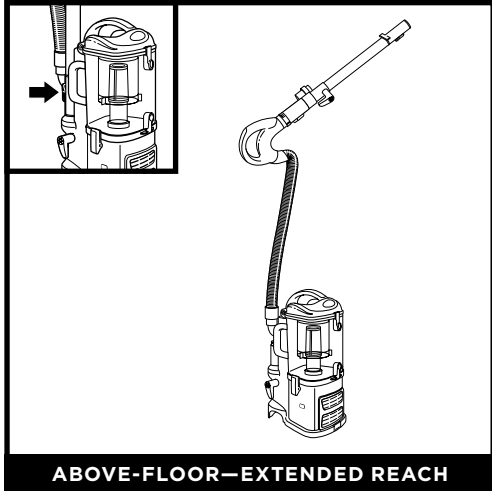

ABOVE-FLOOR—EXTENDED REACH

Follow instructions for detaching the pod above. Press the **Wand Release** button to remove the wand from the pod. Attach an accessory to the end of the wand.

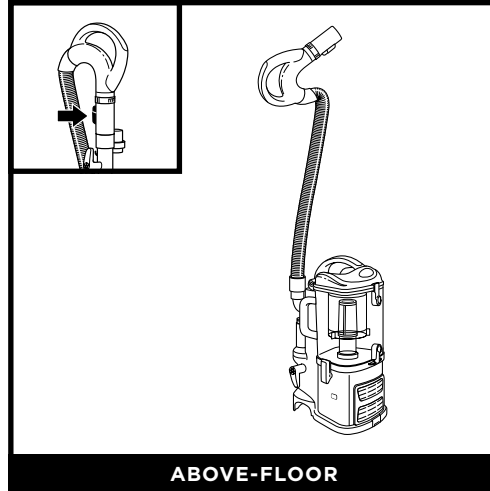

ABOVE-FLOOR

Follow instructions for detaching the pod and wand. Press the **Handle Release** button to detach the handle from the wand. Attach an accessory to the end of the handle.

**NOTE:** All accessories are compatible with both the wand and the handle.

## EMPTYING THE DUST CUP

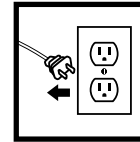

**IMPORTANT:** Unplug the power cord before performing any maintenance.

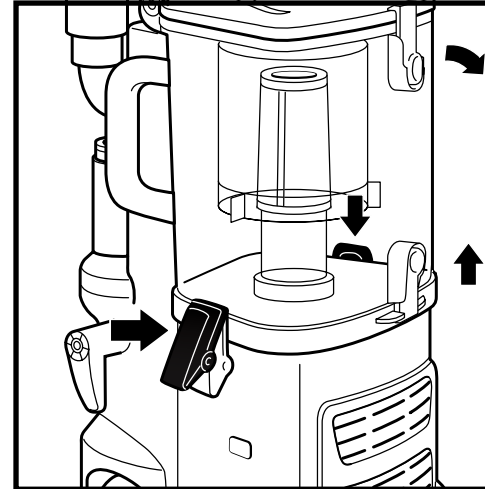

Undo the **Latches** on the sides of the dust cup by lifting them up and out. Tilt the dust cup and lift it off the vacuum pod.

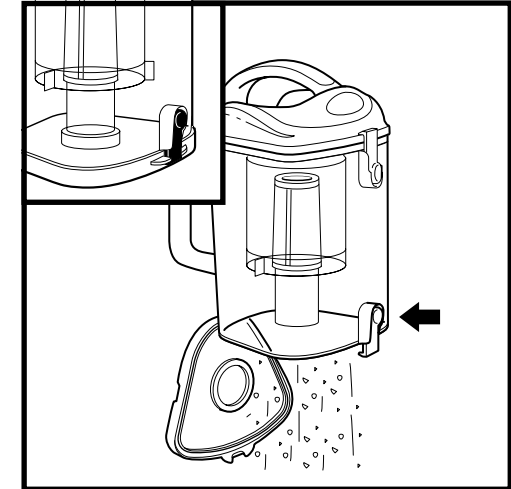

To empty debris into trash, press lower release button and bottom of dust cup will drop open.

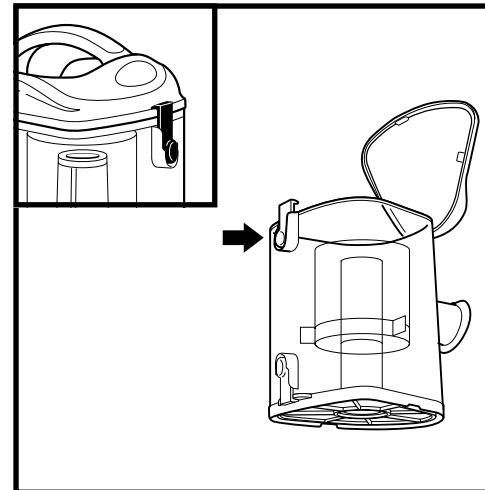

To remove collected debris from **Lint Screen**, press top release button and lift handle to open. Gently brush lint screen to clean.

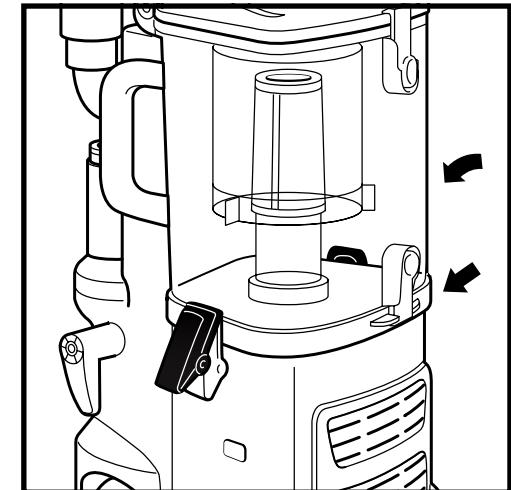

To reinstall, set bottom of dust cup on pod and tilt until dust cup clicks into place.

## CLEANING AND REPLACING THE FILTERS

### CLEANING FILTERS

**Regularly clean and replace the filters to keep your vacuum's suction power optimal.**

To clean filters, rinse with cold water **ONLY** to prevent damage from cleaning chemicals. Allow all filters to air-dry for at least 24 hours before reinstalling them to prevent liquid from being drawn into electric parts.

**IMPORTANT: DO NOT** use soap when cleaning the filters.

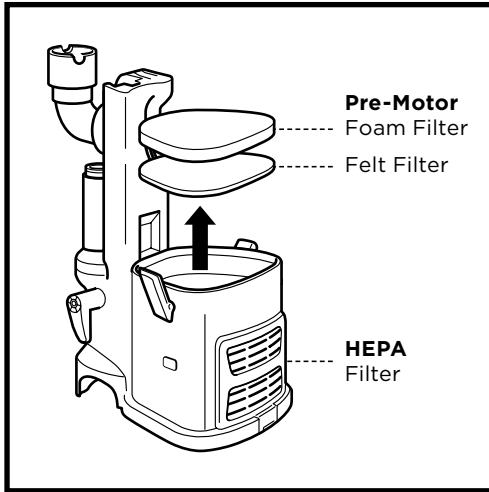

**Pre-Motor (foam and felt):**  
With the dust cup removed, remove the **Foam and Felt Filters**.  
**CLEAN PRE-MOTOR FILTERS EVERY 3 MONTHS.**

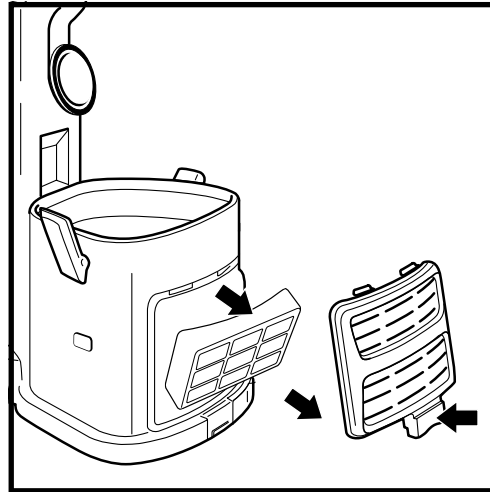

### REPLACING FILTERS

Follow the previous instructions for removing filters. The pre-motor filter should be replaced every 2.5 years. The HEPA filter should be replaced every 3 years.

**Replacement  
Pre-Motor Foam &  
Felt Filter Kit**  
XFF80

**Replacement  
HEPA Filter**  
XHF80

**NOTE:** To order replacement parts and filters, visit [sharkaccessories.com](http://sharkaccessories.com).

## CLEANING THE BRUSHROLL

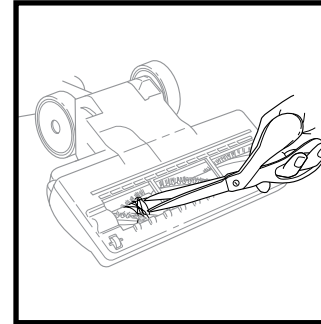

1. Detach the pod from the floor nozzle.
2. Remove any blockages or buildup from the airways in the nozzle. With scissors, carefully cut away any fibers, hair, or string wrapped around the brushroll. Avoid damaging or cutting the bristles.

## CLEANING THE PET POWER BRUSH

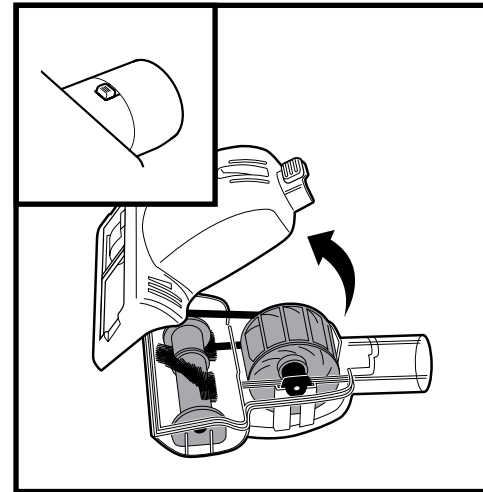

Slide the locking latch forward and gently lift off the cover. Carefully remove any blockage or debris. With scissors, cut away any hair or string wrapped around the rotating bristle brush.

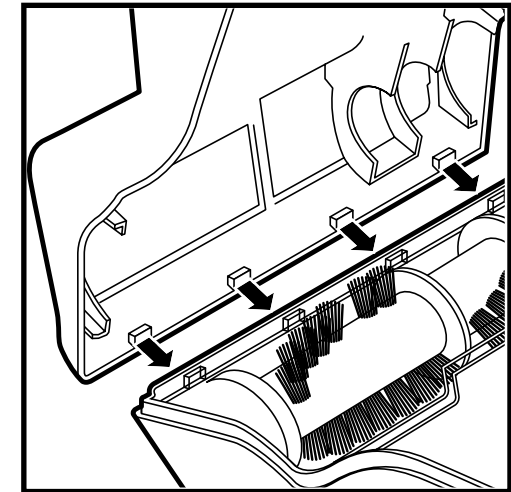

To reassemble, insert the tabs on the front edge of the bottom cover into the matching holes in the top half. Lower the cover and press it down until it clicks into place.

## CHECKING FOR BLOCKAGES

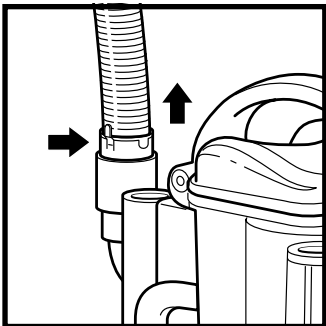

Detach the handle from the wand by pressing the handle release button. Remove the flexible hose from the vacuum pod by pressing the tabs on the hose collar. Inspect the hose for clogs.

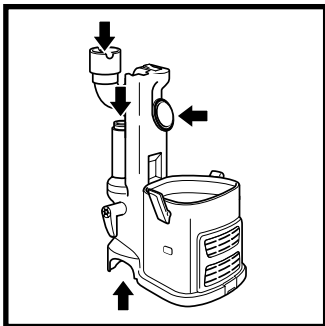

Detach the extension wand, handle, flexible hose, and dust cup. Check all openings and remove blockages.

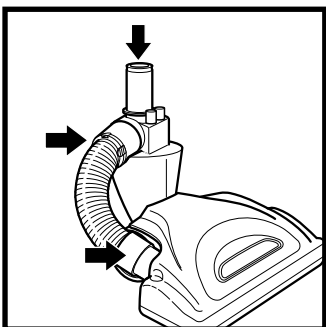

With the pod detached, remove the lower nozzle hose and check for clogs.

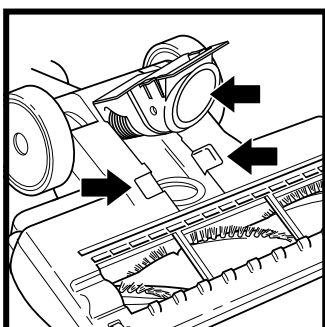

Open the airway on the bottom of the floor nozzle by squeezing the tabs on the sides and lifting up. Check for clogs and clear away any obstructions.

## TROUBLESHOOTING

### Vacuum is not picking up dirt. No suction or light suction.

- Check filters to see if they need cleaning. Follow instructions for rinsing and drying the filters before reinstalling. See *Cleaning and Replacing the Filters* for more information.
- Dust cup may be full; empty dust cup.
- Check hose, hose connections, nozzle, and accessories for blockages; clear blockages if required.
- Close the suction release on the hose to increase suction power.
- If dust cup is empty, and attachment inlets are clear, check for other blockages. See *Checking for Blockages* for more information.

### Vacuum lifts area rugs.

- Suction is powerful. Take care when vacuuming area rugs or rugs with delicately sewn edges. Rotate suction control collar counterclockwise to decrease suction power.

### Brushroll is jammed or has shut off.

- Immediately turn off and unplug vacuum, disconnect the nozzle, and remove blockage before reconnecting and turning vacuum back on. See *Checking for Blockages* for more information.

### Vacuum turns off on its own or indicator light flashes red.

This vacuum is equipped with a motor-protective thermostat. If your vacuum overheats, the thermostat will automatically turn the suction motor off. Perform the following steps to restart the thermostat:

1. Turn vacuum off and unplug it.
2. Empty dust cup and clean filters.
3. Check for blockages in hose, accessories, and inlet openings.
4. Allow unit to cool for a minimum of 45 minutes.
5. Plug in vacuum and turn it on.

Note: If vacuum still does not start, contact Customer Service at: 1-800-798-7398.

## FIVE (5) YEAR LIMITED WARRANTY

The Five (5) Year Limited Warranty applies to purchases made from authorized retailers of **SharkNinja Operating LLC**. Warranty coverage applies to the original owner and to the original product only and is not transferable.

SharkNinja warrants that the unit shall be free from defects in material and workmanship for a period of five (5) years from the date of purchase when it is used under normal household conditions and maintained according to the requirements outlined in the Owner's Guide, subject to the following conditions and exclusions:

### What is covered by this warranty?

1. The original unit and/or non-wearable components deemed defective, in SharkNinja's sole discretion, will be repaired or replaced up to five (5) years from the original purchase date.
2. In the event a replacement unit is issued, the warranty coverage ends six (6) months following the receipt date of the replacement unit or the remainder of the existing warranty, whichever is later. SharkNinja reserves the right to replace the unit with one of equal or greater value.

### What is not covered by this warranty?

1. Normal wear and tear of wearable parts (such as foam filters, HEPA filters, pads, etc.), which require regular maintenance and/or replacement to ensure the proper functioning of your unit, are not covered by this warranty. Replacement parts are available for purchase at [sharkaccessories.com](http://sharkaccessories.com).
2. Any unit that has been tampered with or used for commercial purposes.
3. Damage caused by misuse (e.g., vacuuming up water or other liquids), abuse, negligent handling, failure to perform required maintenance (e.g., not cleaning the filters), or damage due to mishandling in transit.
4. Consequential and incidental damages.
5. Defects caused by repair persons not authorized by SharkNinja. These defects include damages caused in the process of shipping, altering, or repairing the SharkNinja product (or any of its parts) when the repair is performed by a repair person not authorized by SharkNinja.
6. Products purchased, used, or operated outside North America.

### How to get service

If your appliance fails to operate properly while in use under normal household conditions within the warranty period, visit [sharkclean.com/support](http://sharkclean.com/support) for product care and maintenance self-help. Our Customer Service Specialists are also available at **1-800-798-7398** to assist with product support and warranty service options, including the possibility of upgrading to our VIP warranty service options for select product categories.

SharkNinja will cover the cost for the customer to send in the unit to us for repair or replacement. A fee of \$24.95 (subject to change) will be charged when SharkNinja ships the repaired or replacement unit.

### How to initiate a warranty claim

You must call **1-800-798-7398** to initiate a warranty claim. You will need the receipt as proof of purchase. A Customer Service Specialist will provide you with return and packing instruction information.

### How state law applies

This warranty gives you specific legal rights, and you also may have other rights that vary from state to state. Some states do not permit the exclusion or limitation of incidental or consequential damages, so the above may not apply to you.

**REGISTER YOUR PURCHASE**

 registeryourshark.com

 Scan QR code using mobile device



Benefits of registering your product and creating an account:

- Get easier, faster product support and access to warranty information
- Access troubleshooting and product care instructions
- Be among the first to know about exclusive product promotions

**RECORD THIS INFORMATION**

Model Number: \_\_\_\_\_

Serial Number: \_\_\_\_\_

Date of Purchase: \_\_\_\_\_  
(Keep receipt)

Store of Purchase: \_\_\_\_\_

**TIP:** You can find the model and serial numbers on the QR code label on the bottom of the back of the vacuum pod.

**TECHNICAL SPECIFICATIONS**

Voltage: 120V, 60Hz

Watts: 1200W

Amps: 10A



**PLEASE READ CAREFULLY AND KEEP FOR FUTURE REFERENCE.**

This Owner's Guide is designed to help you get a complete understanding of your new Shark® Navigator™ Lift-Away® DLX Upright Vacuum.

SharkNinja Operating LLC  
US: Needham, MA 02494  
CAN: Ville St-Laurent, QC H4S 1A7

1-800-798-7398  
sharkclean.com

Illustrations may differ from actual product. We are constantly striving to improve our products; therefore the specifications contained herein are subject to change without notice.

For SharkNinja U.S. Patent information, visit [sharkninja.com/uspatents](http://sharkninja.com/uspatents)

---

© 2019 SharkNinja Operating LLC. SHARK, LIFT-AWAY, and SHARK NAVIGATOR are registered trademarks of SharkNinja Operating LLC. NAVIGATOR is a trademark of SharkNinja Operating LLC.

UV440\_IB\_REV\_Mv3  
PRINTED IN CHINA



@sharkcleaning