

INLINE CENTRIFUGAL FANS VENTS VK PS SERIES

EN

User's
manual

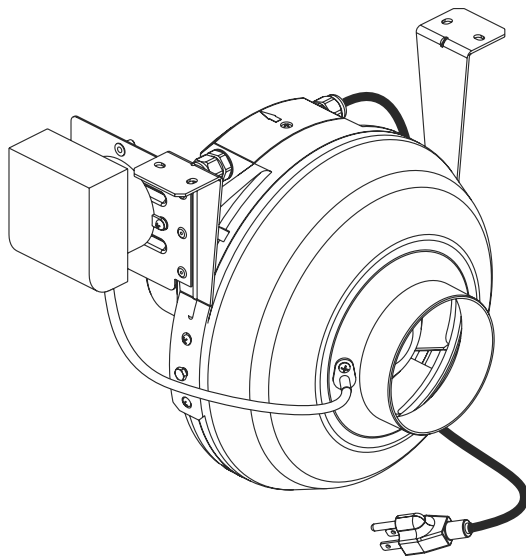



WARNING!

TO REDUCE THE RISK OF FIRE, ELECTRIC SHOCK AND PERSONAL INJURY, READ AND UNDERSTAND THE INSTRUCTIONS CAREFULLY

1. Use the product only in the manner intended by the manufacturer. If you have questions, contact the manufacturer.
2. Before servicing or cleaning the unit, switch off the power at the main service panel and lock it to prevent the power from being accidentally turned on. If the panel cannot be locked securely, mark it with a warning sign. If the unit is not hard-wired but rather plugged into a 120 volt outlet, simply unplug the cord from the receptacle.
3. Installation work and electrical wiring must be done by qualified person(s) in accordance with all applicable codes and standards, include fire-rated construction codes and standards.
4. When cutting or drilling into wall or ceiling, do not damage electrical wiring and other hidden utilities.
5. The fans must always be vented to the outdoors.
6. This fan must be grounded.

CAUTION!

1. For interior use only
2. Do not use the fan to exhaust hazardous or flammable materials and vapors.
3. Install the VK booster fan at least 15 feet from the dryer as close as possible where the duct terminates.
4. To avoid motor damage and noisy and/or unbalanced impeller, keep construction dust off the unit
5. The VK booster fan can be ceiling or wall mounted but vertical mounting is recommended to reduce condensation buildup in the fan
6. For electric dryers only, not suitable for gas dryer
7. Connect the fan through the breaker box.
8. When storing the fan keep it in a dry, weather-protected environment in the original packaging. If the fan has been stored or set in a cold environment, wait 2 hours before connecting it to the power source.
9. Please read specification label on product for further information and requirements.

VK PS fan is designed for installation into a ductwork of a clothes dryer and pressure boosting in the exhaust air duct to increase the clothes dryer operating efficiency. The integrated differential pressure switch controls the turning on/off operations. VK PS turning on/off cycles are synchronized with the turning on/off cycles of the fan in the clothes dryer.

Box includes:

1. Fan - 1
2. Screws and countersinks - 4
3. User's manual - 1

The fans are compatible with 4" (100 mm), 5" (125 mm), 6" (150 mm) diameter ducts.

Understanding the Model Numbers:

The three digit number in all model names indicates the following:

100 (100 mm) means it is used with 4" duct

125 (125 mm) means it is used with 5" duct

150 (150 mm) means it is used with 6" duct

Equipped with a power cord and a plug for connection to a standard wall power socket or with a terminal box for direct connection to power.

The outlet end should always be connected to a duct. Mounting is shown in Fig. 2.

The direction of the air must match the direction of the arrow on the housing.

Input: 120 V AC 60 Hz. Connection to the power source is shown in Fig. 10.

The fan is designed for continuous operation.

Protection rating from access of dangerous parts and water penetration is IPX4.

The fan can be operated at ambient temperatures between +32 °F and +149 °F.

The fans are suitable for vertical or horizontal mounting.

To ensure correct operation of the automation install the differential pressure switch vertically, see Fig. 3.

Remove dust and dirt from the unit surface every 6 months (Fig. 11-18). Disconnect the unit from power mains prior to any maintenance operations. Clean the fan with a soft cloth and a brush using a water-diluted neutral detergent. Protect the electric parts of the fan against ingress of water. After cleaning wipe the product's surface dry.

WARRANTY

Production meets standard operating requirements in the USA and Canada.

VENTS US warrants to the original purchaser of the VK PS series fan that it will be free from defects in materials or workmanship for a period of 60 months from the date of original purchase.

THERE ARE NO OTHER WARRANTIES, EXPRESS OR IMPLIED, INCLUDING, BUT NOT LIMITED TO, IMPLIED WARRANTIES OF MERCHANTABILITY OR FITNESS FOR A PARTICULAR PURPOSE.

During the stated warranty period, VENTS US will, at its option, repair or replace, without charge, any product or part which is found to be defective under normal use and service.

This warranty does not cover (a) normal maintenance and normal service or (b) any products or parts which have been subject to misuse, negligence, accident, improper maintenance or repair (other than by VENTS US), faulty installation or installation contrary to recommended installation instructions. Labor to remove and replace products is not covered. The duration of any implied warranty is limited to the time period specified for the express warranty. Some states do not allow limitations on how long an implied warranty lasts, so the above limitation may not apply to you.

VENTS US OBLIGATION TO REPAIR OR REPLACE, AT VENTS US OPTION, SHALL BE THE PURCHASER'S SOLE AND EXCLUSIVE REMEDY UNDER THIS WARRANTY. VENTS US SHALL NOT BE LIABLE FOR INCIDENTAL, CONSEQUENTIAL OR SPECIAL DAMAGES ARISING OUT OF OR IN CONNECTION WITH PRODUCT USE OR PERFORMANCE.

Some states do not allow the exclusion or limitations of incidental or consequential damages, so the above limitation or exclusion may not apply to you. This warranty gives you specific legal rights, and you may also have other rights which vary from state to state. This warranty supersedes all prior warranties.

If proof of sales date is absent, warranty period is calculated from the production date.

The unit can be exchanged at the following address:
Bodor Vents, LLC
11013 Kenwood Road Cincinnati, Ohio 45242
Phone: (513)348-3853
e-mail: sales@ventsus.com

Please follow guidelines in this manual for product problem-free operation.
Fan construction is constantly being improved, that is why some models can differ slightly from those described in this manual models.

VK PS

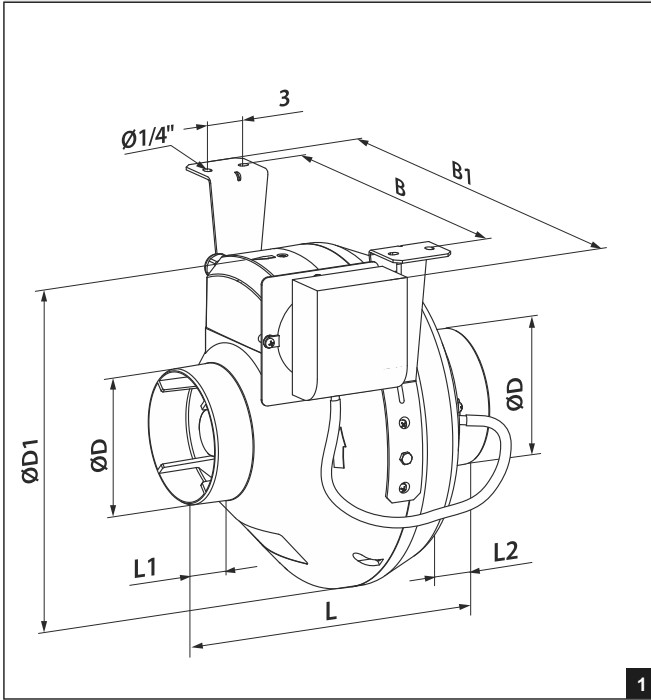

1

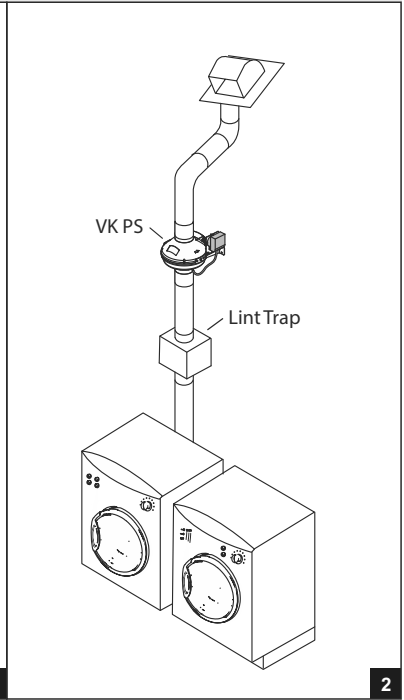

2

Size ranges

Model	Dimensions [in]								Weight [lbs]
	ØD	ØD1	B	B1	L	L1	L2	L3	
VK 100 PS	3 ¹⁵ / ₁₆	9 ¹³ / ₁₆	10 ⁵ / ₈	13 ³ / ₈	9 ¹ / ₁₆	1 ³ / ₁₆	1 ¹ / ₁₆	1 ³ / ₁₆	4.7
VK 125 PS	4 ¹⁵ / ₁₆	9 ¹³ / ₁₆	10 ⁵ / ₈	13 ³ / ₈	8 ¹¹ / ₁₆	1 ³ / ₁₆	1 ¹ / ₁₆	1 ³ / ₁₆	4.9
VK 150 PS	5 ⁷ / ₈	11 ¹³ / ₁₆	12 ⁹ / ₁₆	15 ³ / ₈	11 ¹ / ₄	1 ³ / ₈	1 ³ / ₈	1 ³ / ₈	5.7

Install a lint trap between the clothes dryer and the fan to increase the service life and maintenance periodicity of VK PS. Clean the lint trap as required.

TYPICAL INSTALLATION

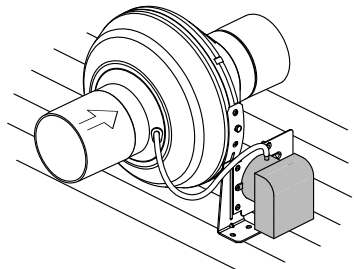
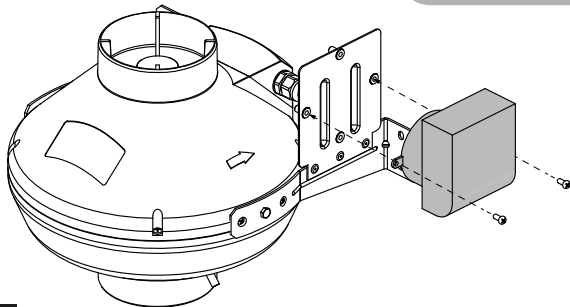
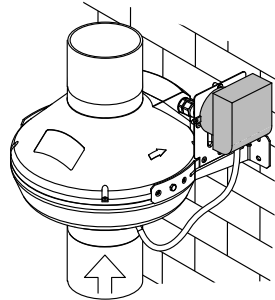
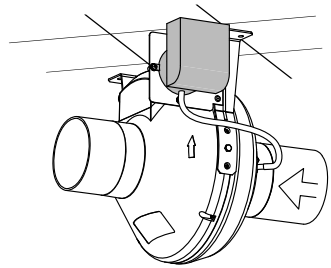
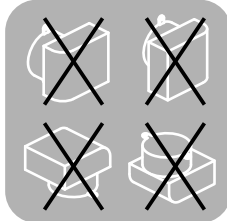
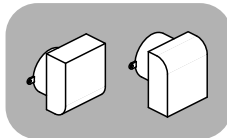
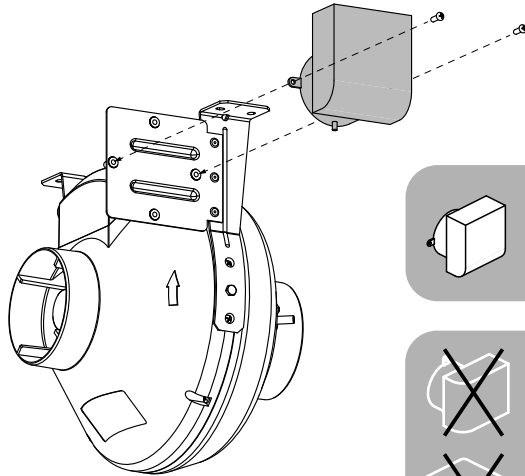

INSTALLATION OF THE FAN

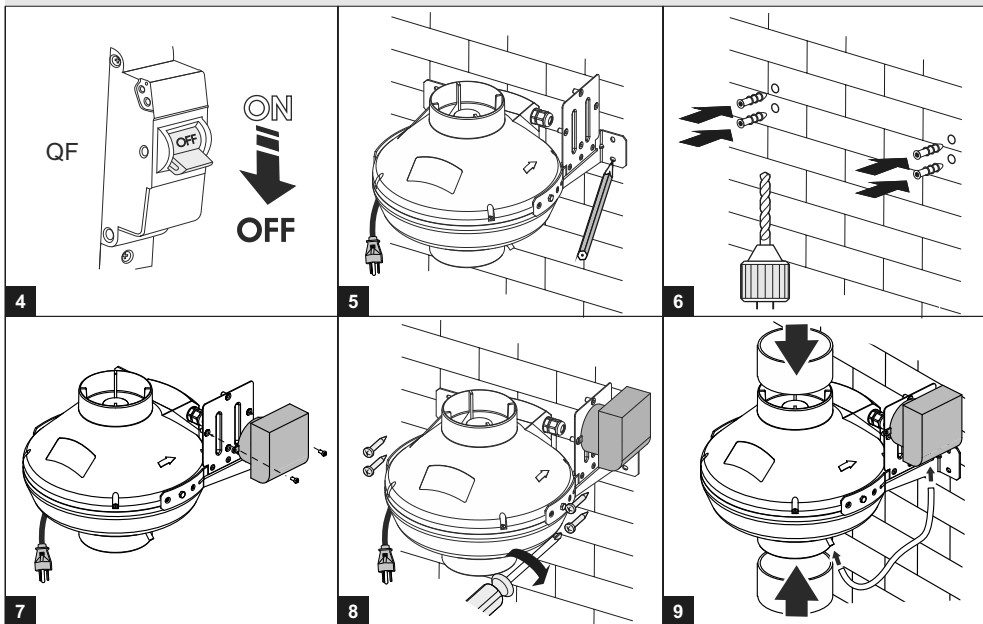

CONNECTION OF THE FAN

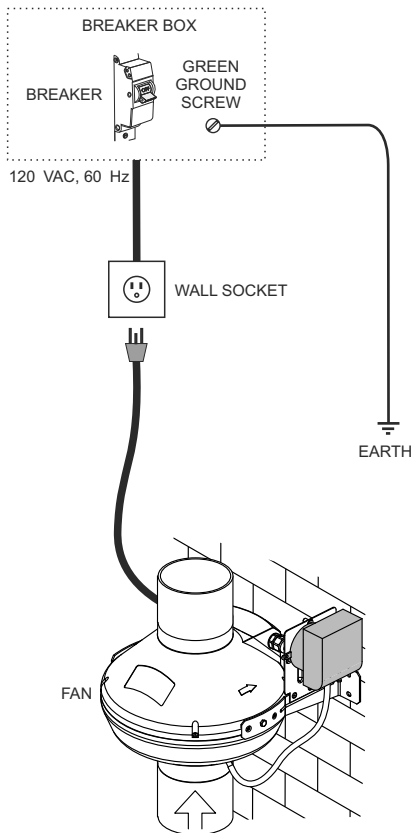

Fan cleaning

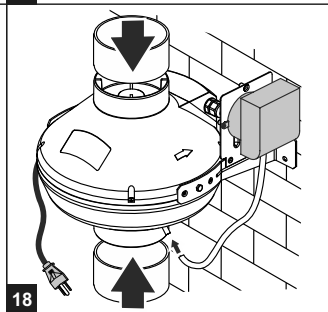
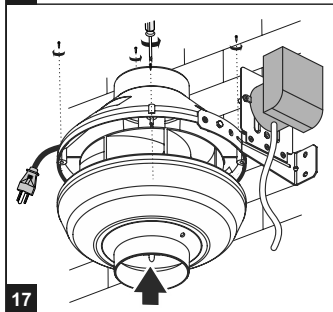
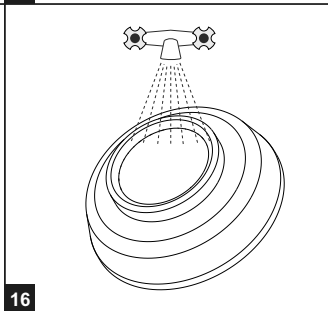
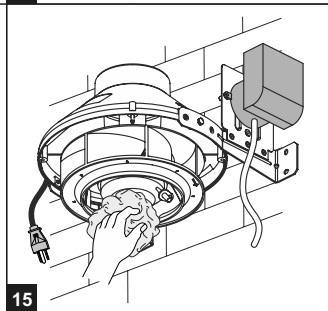
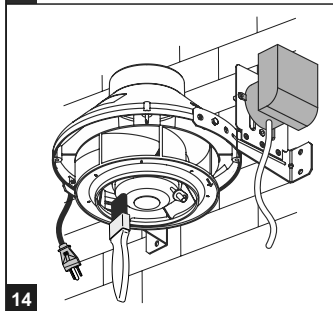
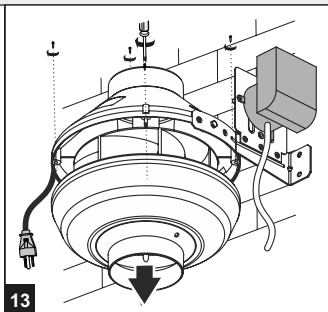
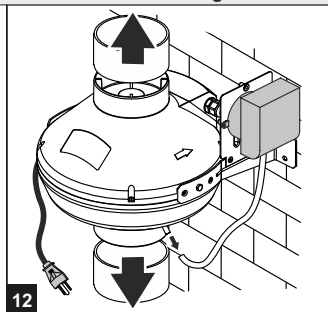
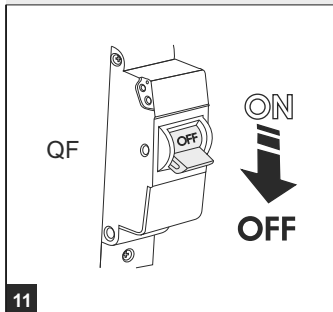

ACCEPTANCE CERTIFICATE

VK PS 100
 125
150

The fan has been duly certified as serviceable.

Approval mark

Manufactured on (date):

Sold by
(name of trading enterprise, stamp of store)

Date of sale

V121EN-01(USA_120)

