

Assembly Instructions

Caution : You must read this before you proceed

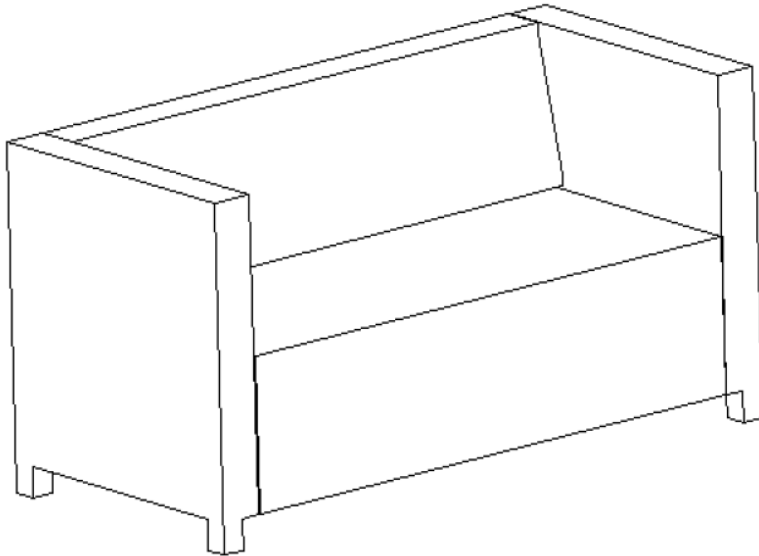





Loveseat



Parts List

Label	Picture	Description	QTY
A		Loveseat - Backrest	1
B		Left Armrest	1
C		Right Armrest	1
D		Seat	1

Hardware

Label	Picture	Description	QTY
F		Plastic Cap(to cover bolt heads)	13
G		Bolt M6*40mm	5
H		Bolt M6*45mm	9
I		Bolt M6*50mm	2
J		Washer Ring	14
K		Spring Washer Ø16*2mm(TH)	14
L		Allen Wrench	1

Assembly Preparation

Before Beginning Assembly:

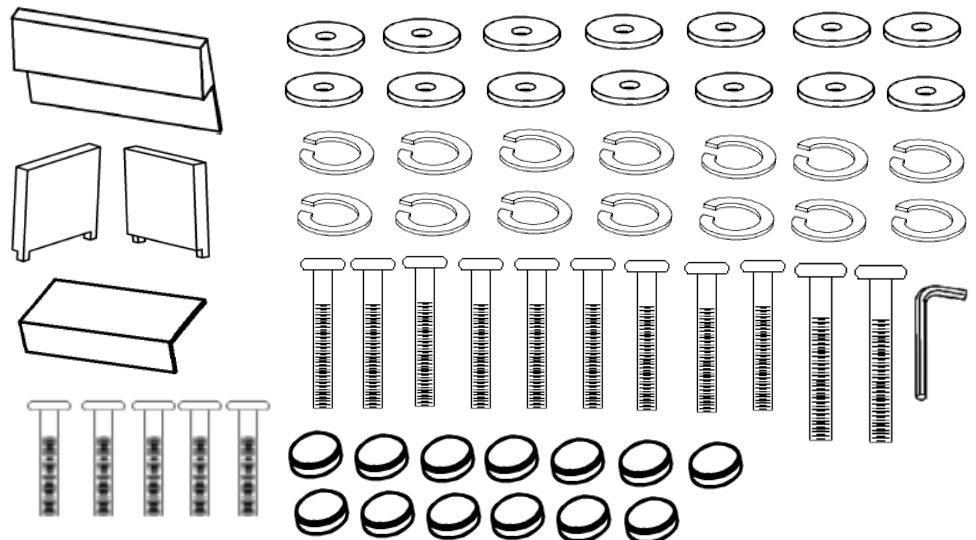

- Read instructions, cover to cover-



- Have 2 adults on hand for assembly-



- Do not assemble on flooring or carpet-



- Assemble on a clean non-marring surface (packing foam)-



- Save all packaging until finished-

Assembly Steps

Overview

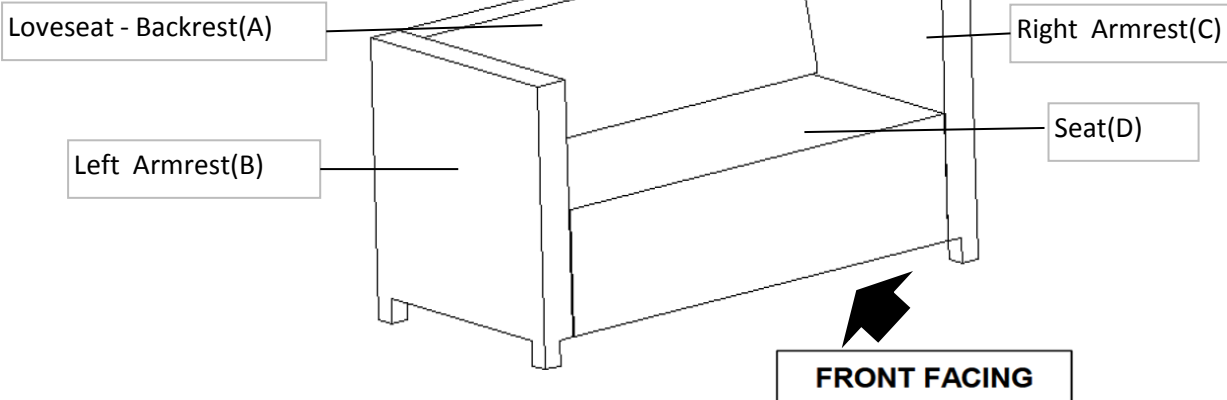

This Loveseat has multiple parts and may require up to some 30 minutes to assemble. To give you an overview of the Loveseat parts, the above picture is to help you put the various parts into perspective. Please read through the instructions here below to familiarise yourself with the parts and steps before assembly.

Step 1

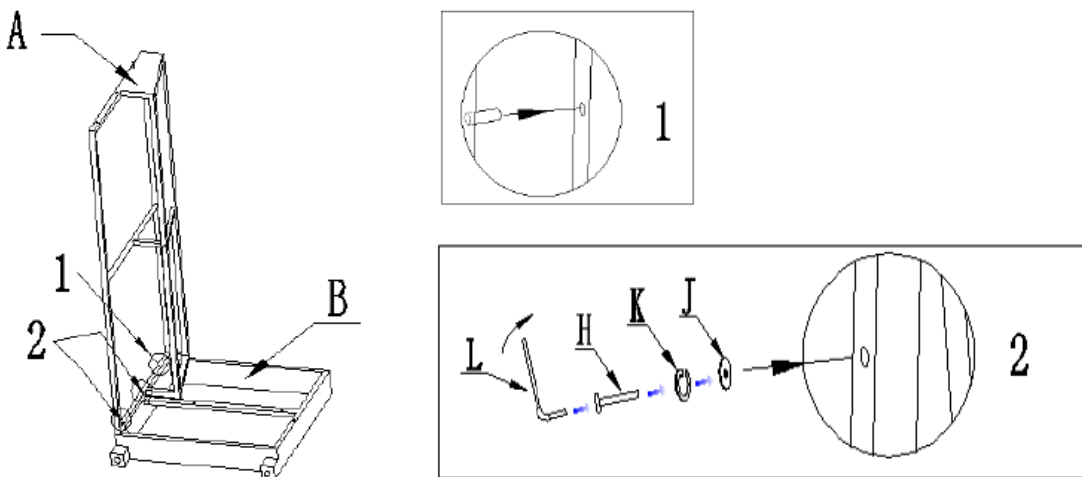

Open the carton and place all the parts onto a clean and soft surface.

Unpack all packages of hardware.

Place the Left Armrest(B) with its inner side, facing skywards .

Put the Backrest(A) against the Left Armrest(B),make the metal rod on the Backrest(A) insert into the MOUNTING POSITIONS of Left Armrest(B) as picture 1 shows.

Attach Backrest(A) and Left Armrest(B) together with hardware as picture 2 shows.

Use an Allen Key(L) to partially tighten these.

Only Loosely Tighten at this stage.

There may be some PE wicker that may have covered the bolt points. To ease assembly, guide and slide the PE wicker away from the mounting positions. DO NOT CUT AWAY any PE WICKER as this would cause the wicker to unravel !

Assembly Steps

Step 2

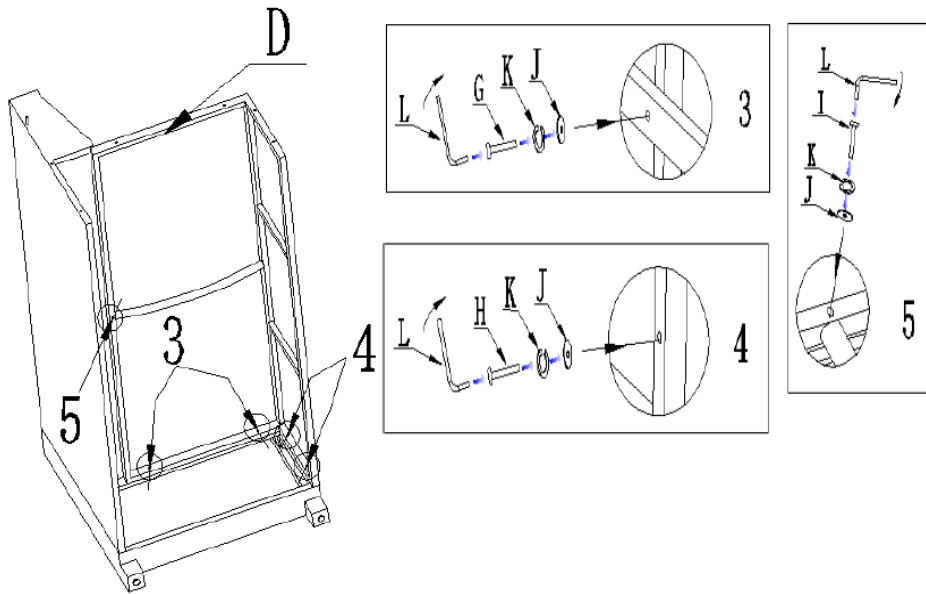

Place the Seat (D) between the Left Armrest(B) and Backrest(A).
Attach the Seat(D) to the Left Armrest(B) with hardware as picture 3 and 4 shows.
Attach Seat(D) to the Backrest(A) with hardware as picture 5 shows.
Use an Allen Key(L) to partially tighten these.
Only Loosely Tighten at this stage.

Step 3

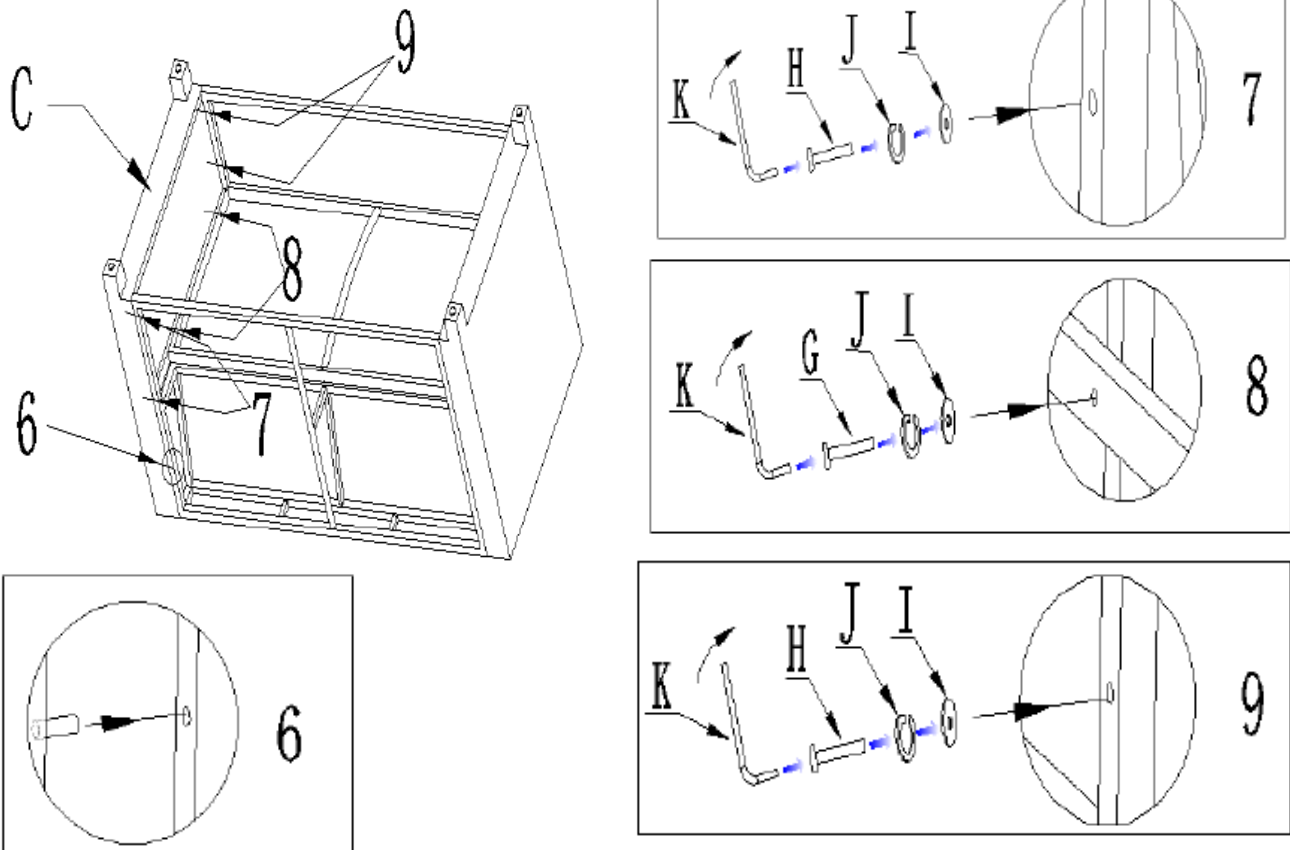

Place the Right Armrest (C) against the Backrest(A) and the Seat(D).
Make the metal rod on Backrest(A) insert into the MOUNTING POSITIONS of Right Armrest(C) as picture 6 shows.
Attach the Backrest (A) to the Right Armrest(C) with hardware as picture 7 shows.
Attach the Seat(D) to the Right Armrest(C) with hardware as picture 8 and 9 shows.
Use an Allen Key(L) to partially tighten these.
Only Loosely Tighten at this stage.

Step 4

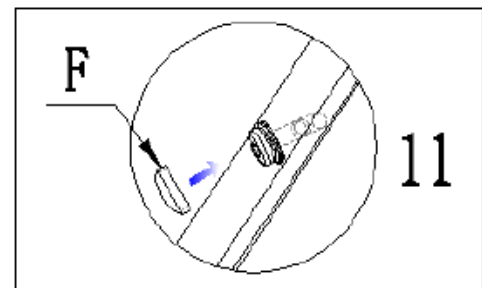
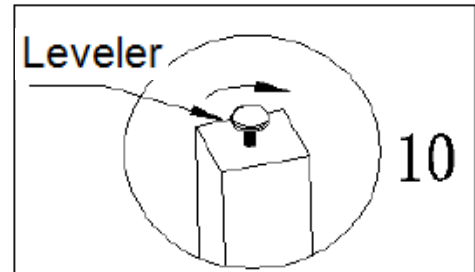
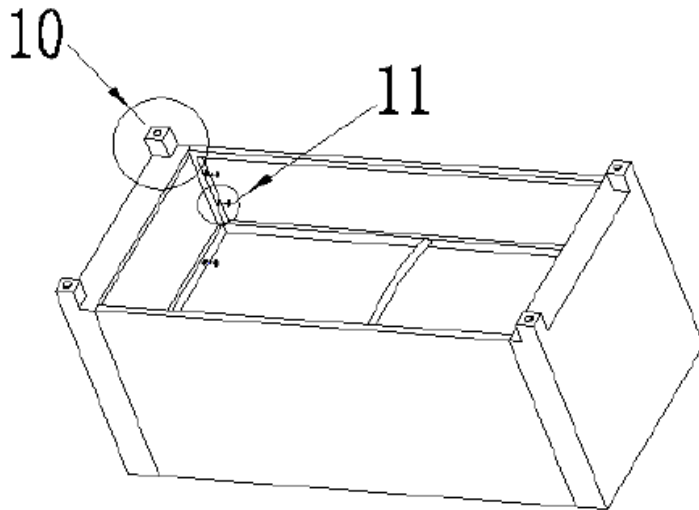

Tighten all Bolts completely, put the Plastic Cap(F)to cover the Bolt heads.
Adjust the Leveler to ensure good stability.

Step 5

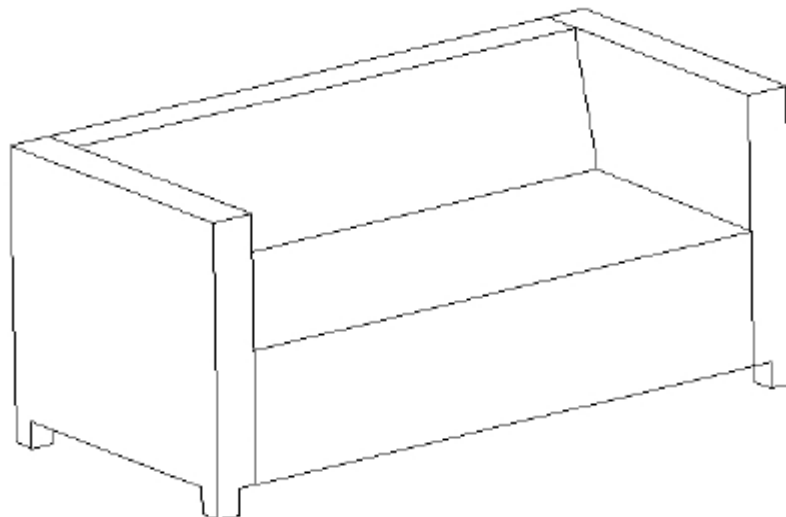

It is ready for use.

Care & Maintenance



- Do not put hot items directly on furniture surface.



- Do not clean furniture with harsh cleansers or polish.



- To obtain the longest lifespan of your outdoor products, minimizing exposure to direct sunlight is recommended.



- Children should not climb or jump on the furniture.



- Do not write on furniture without a padded barrier to protect the surface.



- To obtain the longest lifespan of your outdoor products, avoid extended and lengthy exposure to rain, snow, and direct sunshine. Whenever possible cover the product and /or place under patio or awnings.



- Not for commercial use. For residential use only .



- Stains may be removed with mild soap solution and damp cloth.



- Keep away from sources of ignition.



- Dust and pick-up spills using a clean, non-colored, lint-free cloth .

Assembly Instructions

Caution : You must read this before you proceed



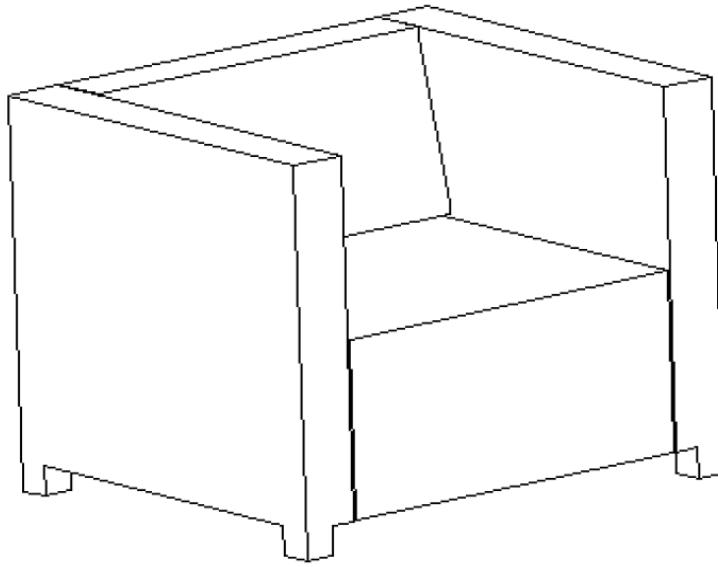

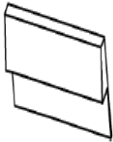
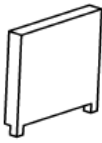
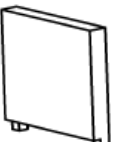
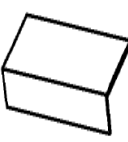

Single Sofa



Parts List

Label	Picture	Description	QTY
A		Sofa - Backrest	1
B		Left Armrest	1
C		Right Armrest	1
D		Sofa Seat	1

Hardware

Label	Picture	Description	QTY
F		Plastic Cap(to cover bolt heads)	13
G		Bolt M6*40mm	5
H		Bolt M6*45mm	9
I		Washer Ring	13
J		Spring Washer Ø16*2mm(TH)	13
K		Allen Wrench	1

Assembly Preparation

Before Beginning Assembly:

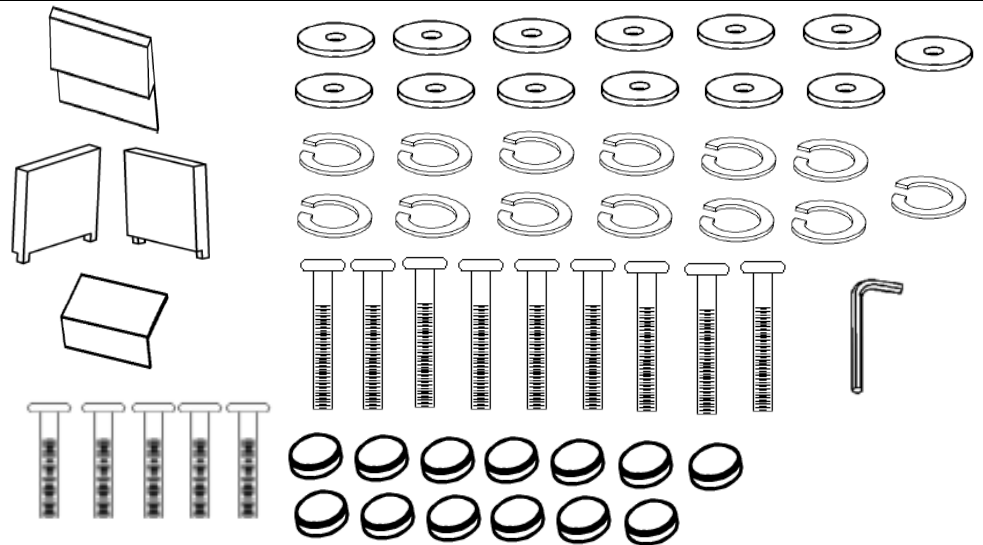

- Read instructions, cover to cover-



- Have 2 adults on hand for assembly-



- Do not assemble on flooring or carpet-



- Assemble on a clean non-marring surface (packing foam)-



- Save all packaging until finished-

Assembly Steps

Overview

Sofa - Backrest(A)

Left Armrest(B)

Right Armrest(C)

Sofa Seat(D)

FRONT FACING

This Single Sofa has multiple parts and may require up to some 30 minutes to assemble. To give you an overview of the Single Sofa parts, the above picture is to help you put the various parts into perspective. Please read through the instructions herebelow to familiarise yourself with the parts and steps before assembly.

Step 1

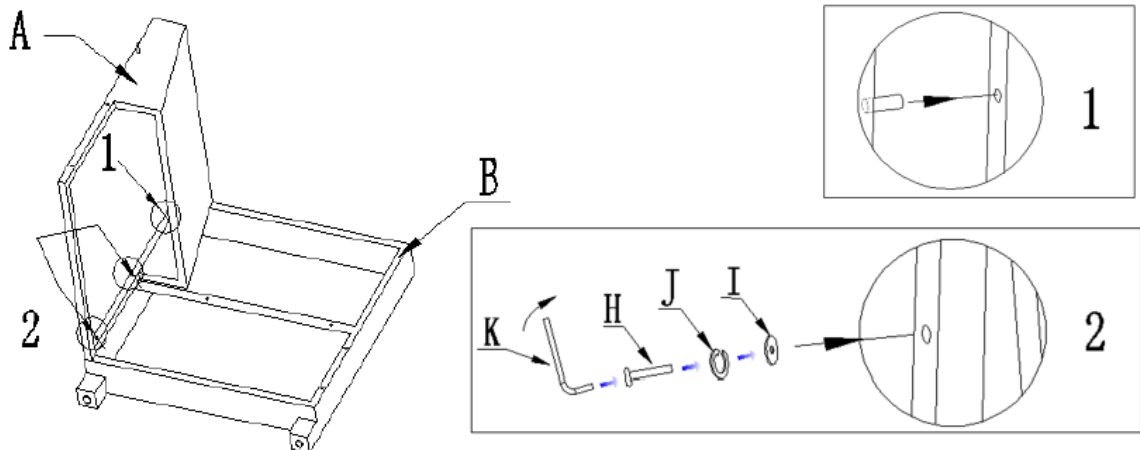

Open the carton and place all the parts onto a clean and soft surface.

Unpack all packages of hardware.

Place the Left Armrest (B) with its inside facing skywards.

Put the Backrest(A) against the Left Armrest(B), make the metal rod on the Backrest(A) insert into the MOUNTING POSITIONS of the Left Armrest(B) as picture 1 shows.

Then attach Backrest(A) and Left Armrest(B) together with hardware as picture 2 shows.

Use an Allen Key(K) to partially tighten these.

Only Loosely Tighten at this stage.

It can happen that some of the PE wicker covers the bolt points, preventing easy assembly the PE wicker should not be cut but only moved away from the mounting positions.

Assembly Steps

Step 2

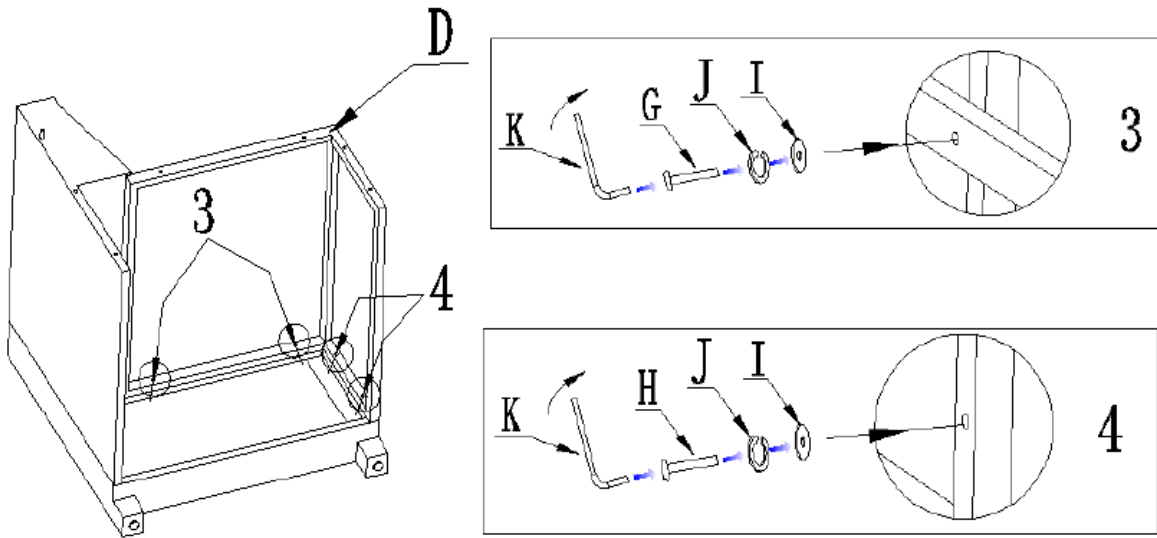

Place the Seat (D) between the Left Armrest(B) and Backrest(A).
Attach the Seat(D) to the Left Armrest(B) with hardware as picture 3 and 4 shows.
Use an Allen Key(L) to partially tighten these.
Only Loosely Tighten at this stage.

Step 3

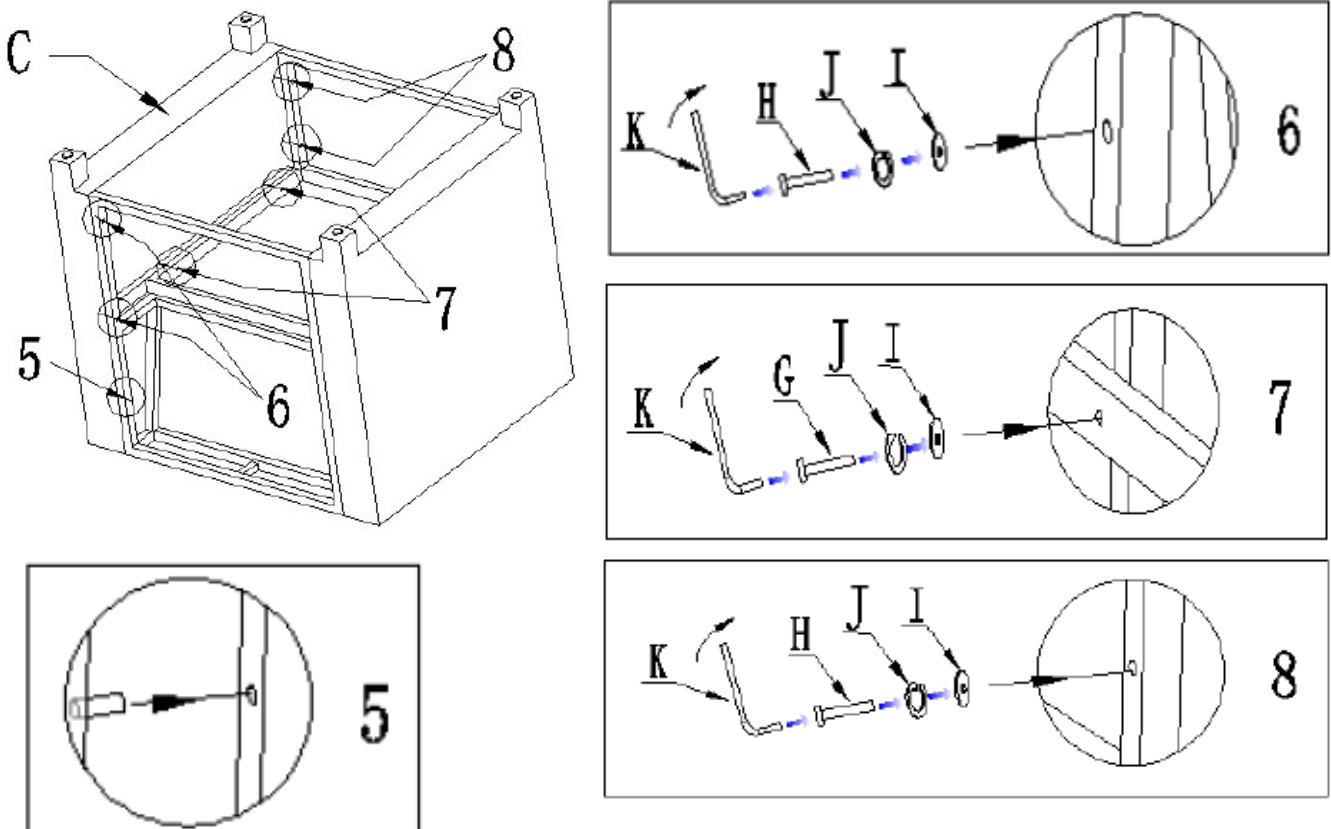

Place the Right Armrest (C) against the Backrest(A) and Seat(D).
Make the metal rod on the Backrest(A) insert into the MOUNTING POSITIONS of the Right Armrest(C) as picture 5 shows.
Attach the Right Armrest(C) to Backrest(A) with hardware as picture 6 shows.
Attach the Right Armrest(C) to Seat(D) with hardware as picture 7 and 8 shows.
Use an Allen Key(K) to partially tighten these.
Only Loosely Tighten at this stage.

Step 4

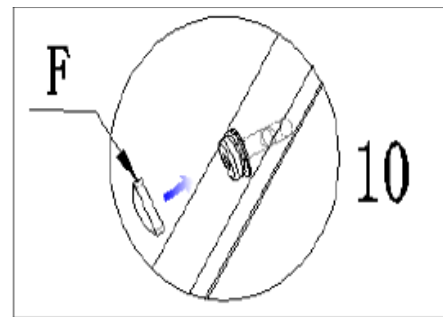
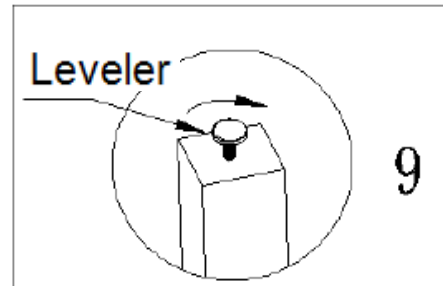
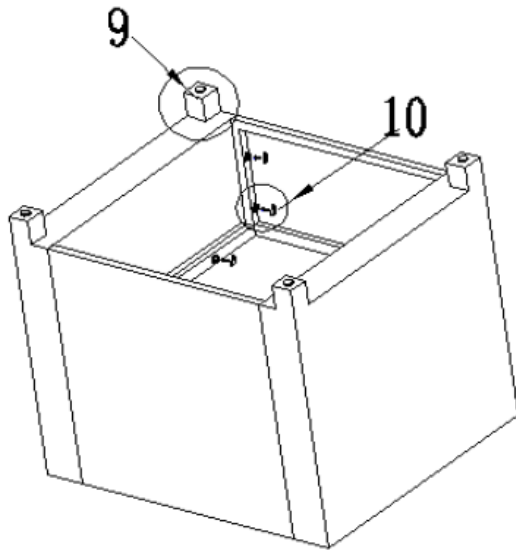

Tighten all bolts completely.
Put the Plastic Cap(F) to cover the bolt heads, adjust the Leveler to ensure good stability.

Step 5

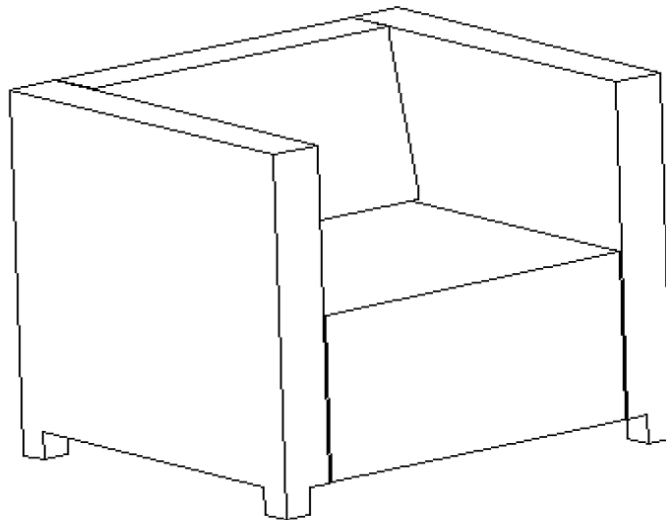

It is ready for use.

Care & Maintenance



- Do not put hot items directly on furniture surface.



- Do not clean furniture with harsh cleansers or polish.



- To obtain the longest lifespan of your outdoor products, minimizing exposure to direct sunlight is recommended.



- Children should not climb or jump on the furniture.



- Do not write on furniture without a padded barrier to protect the surface.



- To obtain the longest lifespan of your outdoor products, avoid extended and lengthy exposure to rain, snow, and direct sunshine. Whenever possible cover the product and /or place under patio or awnings.



- Not for commercial use. For residential use only .



- Stains may be removed with mild soap solution and damp cloth.



- Keep away from sources of ignition.



- Dust and pick-up spills using a clean, non-colored, lint-free cloth .



Assembly Instructions

Caution : You must read this before you proceed

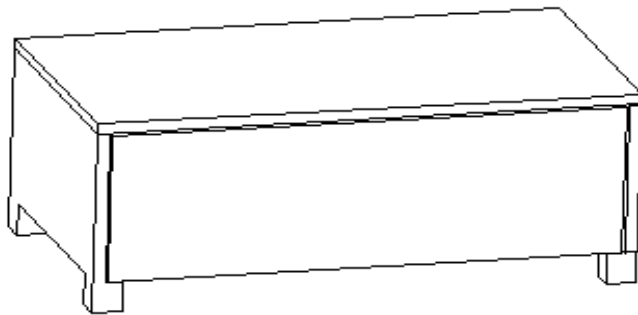

Coffee Table

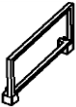

Parts List

Label	Picture	Description	QTY
A		Top Panel	1
B		Front & Back Panel	2
C		Side Panel	2

Hardware

Label	Picture	Description	QTY
E		Plastic Cap(to cover bolt heads)	12
F		Bolt M6*40mm	12

J		Washer Ring	12
K		Spring Washer Ø16*2mm(TH)	12
L		Allen Wrench	1

Assembly Preparation

Before Beginning Assembly:

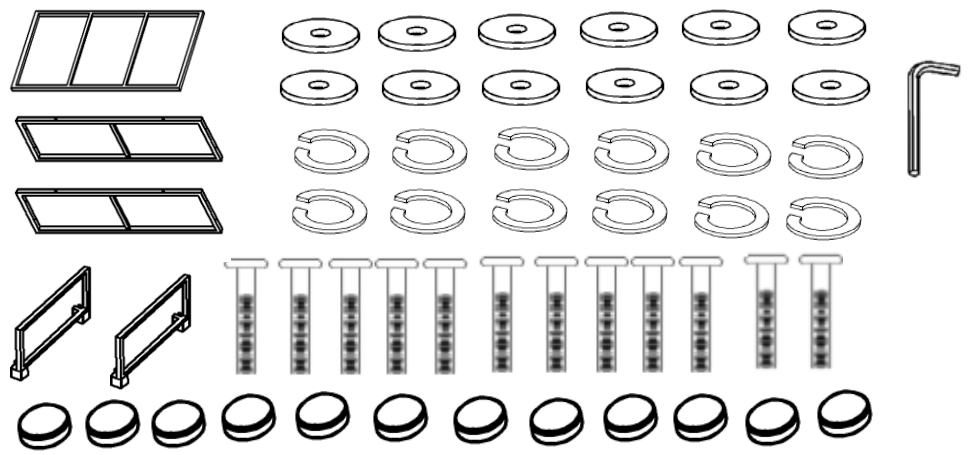

- Read instructions, cover to cover-



- Have 2 adults on hand for assembly-



- Do not assemble on flooring or carpet-



- Assemble on a clean non-marring surface (packing foam)-



- Save all packaging until finished-

Assembly Steps

Overview

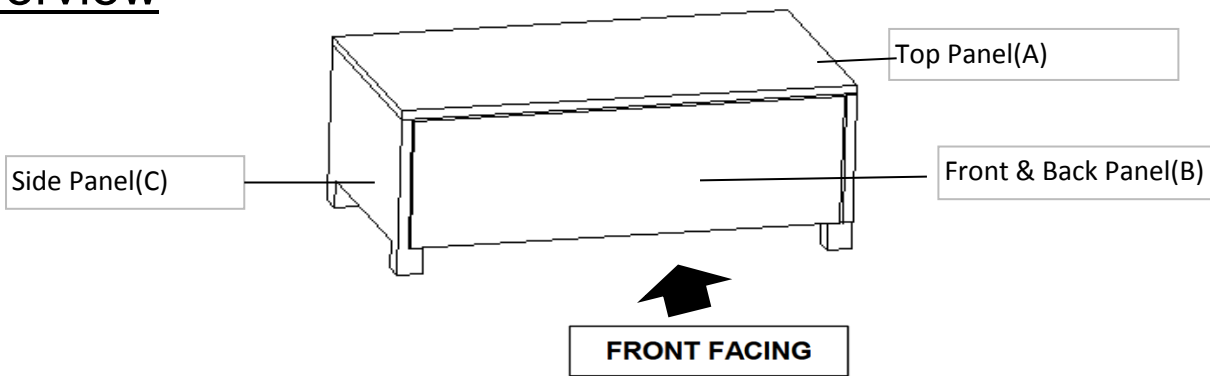

This Coffee Table has multiple parts and may require up to some 30 minutes to assemble. To give you an overview of Coffee Table parts, the above picture is to help you put the various parts into perspective. Please read through the instructions here below to familiarise yourself with the parts and steps before assembly.

Assembly Steps

Step 1

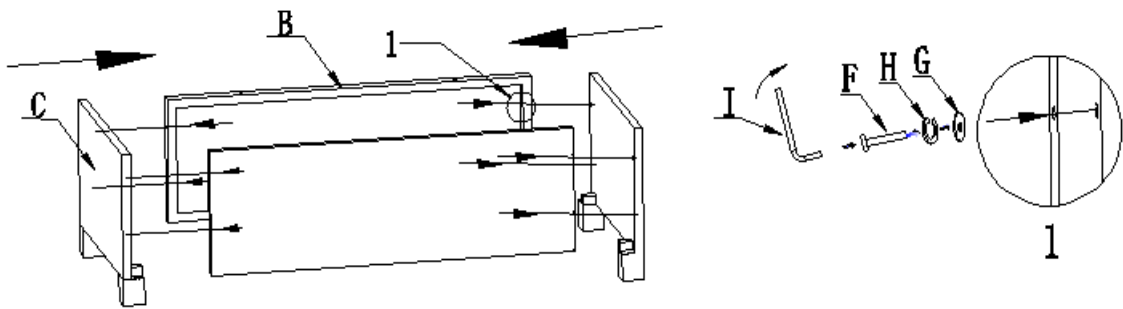

Open the carton and place all the parts onto a clean and soft surface, compare the real parts with the list above to make sure every parts is available.

Get total 4 panels in their upright positions, attach each Side Panel(C) to Front & Back Panle(B) with Washer Ring(G), Spring Washer(H) and Bolt(F) to form a body base,

Install the two pieces of side plate(B) to the two feet(C),use allen key(I) to tighten them.

Only Loosly Tighten at this stage.

Step 2

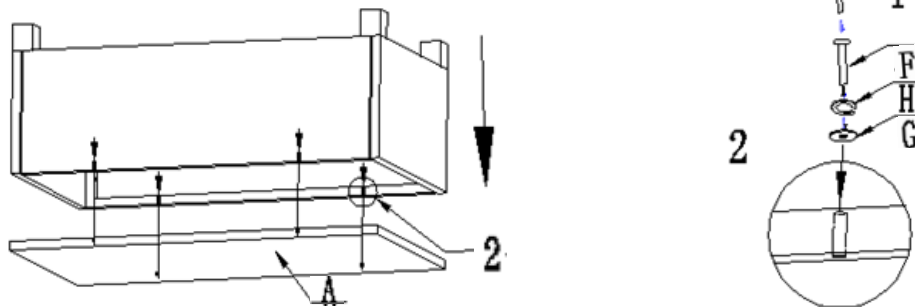

Put the Top Panel(A) with its face down onto a safe surface, turn the body base upside down and place it onto the Top Panel(A).

Attach the Top Panel(A) with Washer Ring(G), Spring Washer(H) and Bolt(F) to make a whole body, and use allen key (I) to tighten them.

Only Loosely Tighten at this stage.

Step 3

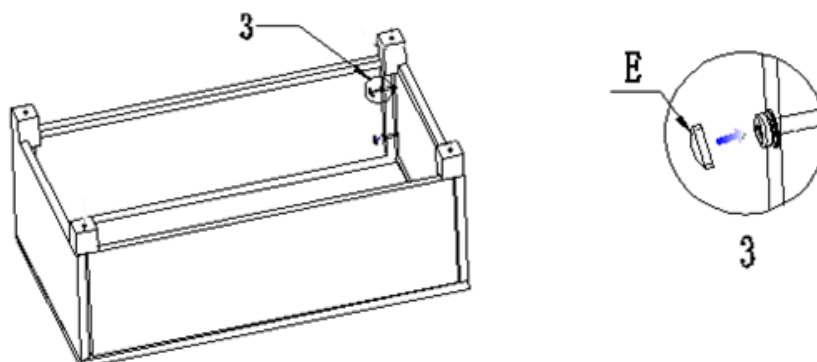

Tighten all Bolts completely, put the Plastic Cap(E)to cover the Bolt heads.





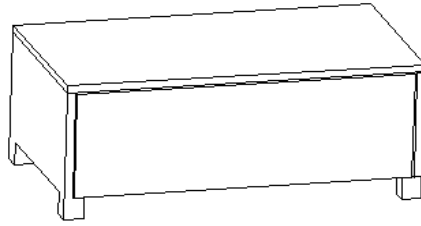















Adjust the Leveler to ensure good stability.

Step 4



It is ready for use.

Care & Maintenance

-   • Do not put hot items directly on furniture surface.
 -   • Do not clean furniture with harsh cleansers or polish.
 -   • To obtain the longest lifespan of your outdoor products, minimizing exposure to direct sunlight is recommended.
 -   • Children should not climb or jump on the furniture.
 -   • Do not write on furniture without a padded barrier to protect the surface.
 -   • To obtain the longest lifespan of your outdoor products, avoid extended and lengthy exposure to rain, snow, and direct sunshine. Whenever possible cover the product and /or place under patio or awnings.
 -   • Not for commercial use. For residential use only .
 -   • Stains may be removed with mild soap solution and damp cloth.
 -   • Keep away from sources of ignition.
-
-   • Dust and pick-up spills using a clean, non-colored, lint-free cloth .