

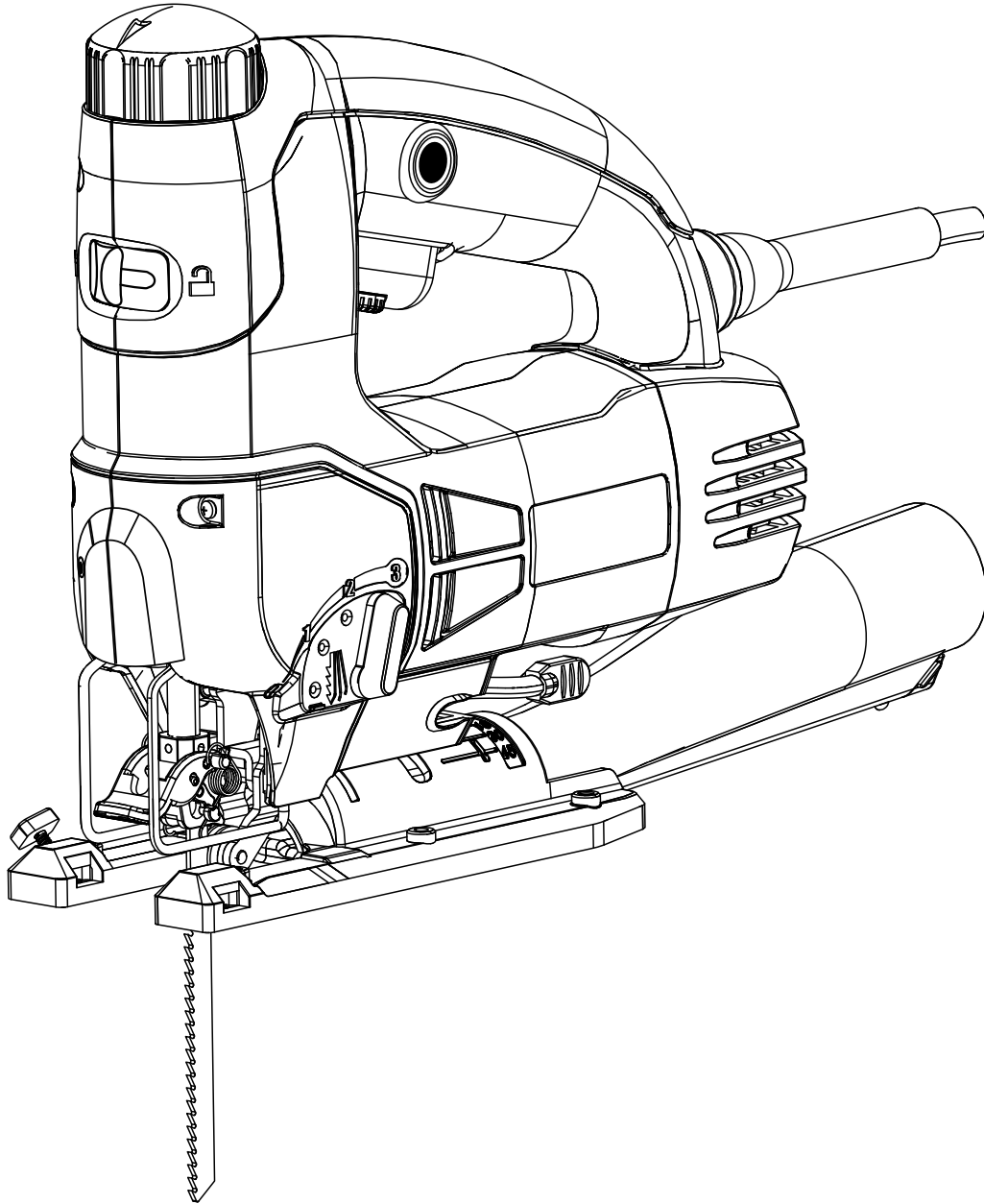

OPERATOR'S MANUAL

Orbital Scrolling Jig Saw with Laser JS550L



Your new jig saw has been engineered and manufactured to our high standard for dependability, ease of operation, and operator safety. When properly cared for, it will give you years of rugged, trouble-free performance.

⚠ WARNING: To reduce the risk of injury, the user must read and understand the operator's manual before using this product.

Thank you for your purchase.

SAVE THIS MANUAL FOR FUTURE REFERENCE

TABLE OF CONTENTS

■ Introduction	2
■ Warranty	2
■ General Safety Rules.....	3-4
■ Specific Safety Rules	4
■ Symbols	5-6
■ Electrical.....	7
■ Features.....	8-9
■ Unpacking	10
■ Assembly.....	10
■ Operation.....	11-16
■ Adjustments	17-18
■ Maintenance.....	19
■ Parts Ordering / Service.....	20

INTRODUCTION

This tool has many features for making its use more pleasant and enjoyable. Safety, performance, and dependability have been given top priority in the design of this product making it easy to maintain and operate.

WARRANTY

RYOBI® POWER TOOL - LIMITED TWO YEAR WARRANTY AND 30 DAY EXCHANGE POLICY

One World Technologies, Inc., warrants its RYOBI® power tools with the following conditions:

30-DAY EXCHANGE POLICY: During the first 30 days after date of purchase, you may either request service under this warranty or you may exchange any RYOBI® power tool which does not work properly due to defective workmanship or materials by returning the power tool to the dealer from which it was purchased. To receive a replacement power tool or requested warranty service, you must present proof of purchase and return all original equipment packaged with the original product. The replacement power tool will be covered by the limited warranty for the balance of the two year period from the date of the original purchase.

WHAT THIS WARRANTY COVERS: This warranty covers all defects in workmanship or materials in your RYOBI® power tool for a period of two years from the date of purchase. With the exception of batteries, power tool accessories are warranted for ninety (90) days. Batteries are warranted for two years.

HOW TO GET SERVICE: Just return the power tool, properly packaged and postage prepaid, to an Authorized Service Center. You can obtain the location of the Service Center nearest you by contacting a service representative at One World Technologies, Inc., P.O. Box 1207, Anderson, SC 29622-1207, by calling 1-800-525-2579 or by logging on to www.ryobitools.com. When you request warranty service, you must also present proof of purchase documentation, which includes the date of purchase (for example, a bill of sale). We will repair any faulty workmanship, and either repair or replace any defective part, at our option. We will do so without any charge to you. We will complete the work in a reasonable time, but, in any case, within ninety (90) days or less.

WHAT'S NOT COVERED: This warranty applies only to the original purchaser at retail and may not be transferred. This warranty only covers defects arising under normal usage and does not cover any malfunction, failure or defects resulting from misuse, abuse, neglect, alteration, modification or repairs by other than Authorized Service Centers. One World Technologies, Inc. makes no warranties, representations or promises as to the quality or performance of its power tools other than those specifically stated in this warranty.

ADDITIONAL LIMITATIONS: Any implied warranties granted under state law, including warranties of merchantability or fitness for a particular purpose, are limited to two years from the date of purchase. One World Technologies, Inc. is not responsible for direct, indirect, or incidental damages, so the above limitations and exclusions may not apply to you. This warranty gives you specific legal rights, and you may also have other rights which vary from state to state.

GENERAL SAFETY RULES



WARNING:

Read and understand all instructions. Failure to follow all instructions listed below, may result in electric shock, fire and/or serious personal injury.

SAVE THESE INSTRUCTIONS

WORK AREA

- **Keep your work area clean and well lit.** Cluttered benches and dark areas invite accidents.
- **Do not operate power tools in explosive atmospheres, such as in the presence of flammable liquids, gases, or dust.** Power tools create sparks which may ignite the dust or fumes.
- **Keep bystanders, children, and visitors away while operating a power tool.** Distractions can cause you to lose control.

ELECTRICAL SAFETY

- **Double insulated tools are equipped with a polarized plug (one blade is wider than the other). This plug will fit in a polarized outlet only one way. If the plug does not fit fully in the outlet, reverse the plug. If it still does not fit, contact a qualified electrician to install a polarized outlet. Do not change the plug in any way.** Double insulation  eliminates the need for the three-wire grounded power cord and grounded power supply system.
- **Avoid body contact with grounded surfaces such as pipes, radiators, ranges, and refrigerators.** There is an increased risk of electric shock if your body is grounded.
- **Don't expose power tools to rain or wet conditions.** Water entering a power tool will increase the risk of electric shock.
- **Do not abuse the cord. Never use the cord to carry the tools or pull the plug from an outlet. Keep cord away from heat, oil, sharp edges, or moving parts. Replace damaged cords immediately.** Damaged cords increase the risk of electric shock.
- **When operating a power tool outside, use an outdoor extension cord marked "W-A" or "W".** These cords are rated for outdoor use and reduce the risk of electric shock.

PERSONAL SAFETY

- **Stay alert, watch what you are doing and use common sense when operating a power tool. Do not use tool while tired or under the influence of drugs, alcohol, or medication.** A moment of inattention while operating power tools may result in serious personal injury.
- **Dress properly. Do not wear loose clothing or jewelry. Contain long hair. Keep your hair, clothing, and gloves away from moving parts.** Loose clothes, jewelry, or long hair can be caught in moving parts.

- **Avoid accidental starting. Be sure switch is off before plugging in.** Carrying tools with your finger on the switch or plugging in tools that have the switch on invites accidents.
- **Remove adjusting keys or wrenches before turning the tool on.** A wrench or a key that is left attached to a rotating part of the tool may result in personal injury.
- **Do not overreach. Keep proper footing and balance at all times.** Proper footing and balance enables better control of the tool in unexpected situations.
- **Use safety equipment. Always wear eye protection.** Dust mask, nonskid safety shoes, hard hat, or hearing protection must be used for appropriate conditions.
- **Do not wear loose clothing or jewelry. Contain long hair.** Loose clothes, jewelry, or long hair can be drawn into air vents.
- **Do not use on a ladder or unstable support.** Stable footing on a solid surface enables better control of the tool in unexpected situations.

TOOL USE AND CARE

- **Use clamps or other practical way to secure and support the workpiece to a stable platform.** Holding the work by hand or against your body is unstable and may lead to loss of control.
- **Do not force tool. Use the correct tool for your application.** The correct tool will do the job better and safer at the rate for which it is designed.
- **Do not use tool if switch does not turn it on or off.** Any tool that cannot be controlled with the switch is dangerous and must be repaired.
- **Disconnect the plug from power source before making any adjustments, changing accessories, or storing the tool.** Such preventive safety measures reduce the risk of starting the tool accidentally.
- **Store idle tools out of the reach of children and other untrained persons.** Tools are dangerous in the hands of untrained users.
- **Maintain tools with care. Keep cutting tools sharp and clean.** Properly maintained tools with sharp cutting edges are less likely to bind and are easier to control.
- **Check for misalignment or binding of moving parts, breakage of parts, and any other condition that may affect the tool's operation. If damaged, have the tool serviced before using.** Many accidents are caused by poorly maintained tools.
- **Use only accessories that are recommended by the manufacturer for your model.** Accessories that may be suitable for one tool, may become hazardous when used on another tool.
- **Keep the tool and its handle dry, clean and free from oil and grease.** Always use a clean cloth when cleaning. Never use brake fluids, gasoline, petroleum-based products, or any strong solvents to clean your tool. Following this rule will reduce the risk of loss of control and deterioration of the enclosure plastic.

GENERAL SAFETY RULES

SERVICE

- **Tool service must be performed only by qualified repair personnel.** Service or maintenance performed by unqualified personnel may result in a risk of injury.

- **When servicing a tool, use only identical replacement parts. Follow instructions in the Maintenance section of this manual.** Use of unauthorized parts or failure to follow Maintenance Instructions may create a risk of shock or injury.

SPECIFIC SAFETY RULES

- **Hold tool by insulated gripping surfaces when performing an operation where the cutting tool may contact hidden wiring or its own cord.** Contact with a “live” wire will make exposed metal parts of the cutting tool “live” and shock the operator.

ADDITIONAL SAFETY RULES

- **Know your power tool. Read operator’s manual carefully. Learn its applications and limitations, as well as the specific potential hazards related to this tool.** Following this rule will reduce the risk of electric shock, fire, or serious injury.
- **Always wear safety glasses. Everyday eyeglasses have only impact-resistant lenses; they are NOT safety glasses.** Following this rule will reduce the risk of serious personal injury.
- **Protect your lungs. Wear a face or dust mask if the operation is dusty.** Following this rule will reduce the risk of serious personal injury.
- **Protect your hearing. Wear hearing protection during extended periods of operation.** Following this rule will reduce the risk of serious personal injury.
- **Inspect tool cords periodically and, if damaged, have repaired at your nearest Authorized Service Center. Constantly stay aware of cord location.** Following this rule will reduce the risk of electric shock or fire.
- **Check damaged parts. Before further use of the tool, a guard or other part that is damaged should be carefully checked to determine that it will operate properly and perform its intended function. Check for alignment of moving parts, binding of moving parts, breakage of parts, mounting, and any other conditions that may affect its operation. A guard or other part that is damaged should be properly repaired or replaced by an authorized service center.** Following this rule will reduce the risk of shock, fire, or serious injury.
- **Do not abuse cord. Never carry the tool by the cord or yank it to disconnect it from the receptacle. Keep cord away from heat, oil, and sharp edges.** Following this rule will reduce the risk of electric shock or fire.
- **Make sure your extension cord is in good condition. When using an extension cord, be sure to use one**

heavy enough to carry the current your product will draw. A wire gage size (A.W.G.) of at least 14 is recommended for an extension cord 50 feet or less in length. A cord exceeding 100 feet is not recommended. If in doubt, use the next heavier gage. The smaller the gage number, the heavier the cord. An undersized cord will cause a drop in line voltage resulting in loss of power and overheating.

- **Inspect for and remove all nails from lumber before using this tool.** Following this rule will reduce the risk of serious personal injury.
- **Drugs, alcohol, medication. Do not operate tool while under the influence of drugs, alcohol, or any medication.** Following this rule will reduce the risk of electric shock, fire, or serious personal injury.











LASER GUIDE WARNINGS:

The laser guide radiation used in the Ryobi jig saw is Class IIIa with maximum <5mW and 650nm wavelengths. These lasers do not normally present an optical hazard although staring at the beam may cause flash blindness.

- **Caution:** Use of controls or adjustments or performances of procedures other than those specified herein may result in hazardous radiation exposure.
- **Avoid** direct eye exposure when using the laser guide.
- The laser shall be used and maintained in accordance with the manufacturer’s instructions.
- Never aim the beam at a person or object other than the workpiece.
- Always ensure the laser beam is aimed at a sturdy workpiece without reflective surfaces. Shiny reflective sheet metal or similar shiny materials are not suitable for laser use.
- All repairs should be made by an authorized service representative or the laser manufacturer.
- **If the power supply cord is damaged,** it must be replaced only by the manufacturer or by an authorized service center to avoid risk.
- **Save these instructions.** Refer to them frequently and use them to instruct others who may use this tool. If you loan someone this tool, loan them these instructions also.



SYMBOLS

Some of the following symbols may be used on this tool. Please study them and learn their meaning. Proper interpretation of these symbols will allow you to operate the tool better and safer.

SYMBOL	NAME	DESIGNATION/EXPLANATION
V	Volts	Voltage
A	Amperes	Current
Hz	Hertz	Frequency (cycles per second)
W	Watt	Power
min	Minutes	Time
~	Alternating Current	Type of current
==	Direct Current	Type or a characteristic of current
n_0	No Load Speed	Rotational speed, at no load
	Class II Construction	Double-insulated construction
.../min	Per Minute	Revolutions, strokes, surface speed, orbits etc., per minute
	Wet Conditions Alert	Do not expose to rain or use in damp locations.
	Read The Operator's Manual	To reduce the risk of injury, user must read and understand operator's manual before using this product.
	Eye Protection	Always wear safety goggles or safety glasses with side shields and a full face shield when operating this product.
	Safety Alert	Precautions that involve your safety.
	No Hands Symbol	Failure to keep your hands away from the blade will result in serious personal injury.
	No Hands Symbol	Failure to keep your hands away from the blade will result in serious personal injury.
	No Hands Symbol	Failure to keep your hands away from the blade will result in serious personal injury.
	No Hands Symbol	Failure to keep your hands away from the blade will result in serious personal injury.
	Hot Surface	To reduce the risk of injury or damage, avoid contact with any hot surface.

SYMBOLS

The following signal words and meanings are intended to explain the levels of risk associated with this product.

SYMBOL	SIGNAL	MEANING
	DANGER:	Indicates an imminently hazardous situation, which, if not avoided, will result in death or serious injury.
	WARNING:	Indicates a potentially hazardous situation, which, if not avoided, could result in death or serious injury.
	CAUTION:	Indicates a potentially hazardous situation, which, if not avoided, may result in minor or moderate injury.
	CAUTION:	(Without Safety Alert Symbol) Indicates a situation that may result in property damage.

SERVICE

Servicing requires extreme care and knowledge and should be performed only by a qualified service technician. For service we suggest you return the product to your nearest **AUTHORIZED SERVICE CENTER** for repair. When servicing, use only identical replacement parts.

WARNING:

To avoid serious personal injury, do not attempt to use this product until you read thoroughly and understand completely the operator's manual. Save this operator's manual and review frequently for continuing safe operation and instructing others who may use this product.

WARNING:



The operation of any power tool can result in foreign objects being thrown into your eyes, which can result in severe eye damage. Before beginning power tool operation, always wear safety goggles or safety glasses with side shields and a full face shield when needed. We recommend Wide Vision Safety Mask for use over eyeglasses or standard safety glasses with side shields. Always use eye protection which is marked to comply with ANSI Z87.1.

WARNING:

Some dust created by power sanding, sawing, grinding, drilling, and other construction activities contains chemicals known to cause cancer, birth defects or other reproductive harm. Some examples of these chemicals are:

- lead from lead-based paints,
- crystalline silica from bricks and cement and other masonry products, and
- arsenic and chromium from chemically-treated lumber.

Your risk from these exposures varies, depending on how often you do this type of work. To reduce your exposure to these chemicals: work in a well ventilated area, and work with approved safety equipment, such as those dust masks that are specially designed to filter out microscopic particles.

SAVE THESE INSTRUCTIONS

ELECTRICAL

DOUBLE INSULATION

Double insulation is a concept in safety in electric power tools, which eliminates the need for the usual three-wire grounded power cord. All exposed metal parts are isolated from the internal metal motor components with protecting insulation. Double insulated tools do not need to be grounded.

WARNING:

The double insulated system is intended to protect the user from shock resulting from a break in the tool's internal insulation. Observe all normal safety precautions to avoid electrical shock.

NOTE: Servicing of a tool with double insulation requires extreme care and knowledge of the system and should be performed only by a qualified service technician. For service, we suggest you return the tool to your nearest authorized service center for repair. Always use original factory replacement parts when servicing.

ELECTRICAL CONNECTION

This tool has a precision-built electric motor. It should be connected to a **power supply that is 120 volts, 60 Hz, AC only (normal household current)**. Do not operate this tool on direct current (DC). A substantial voltage drop will cause a loss of power and the motor will overheat. If your tool does not operate when plugged into an outlet, double-check the power supply.

EXTENSION CORDS

When using a power tool at a considerable distance from a power source, be sure to use an extension cord that has the capacity to handle the current the tool will draw. An undersized cord will cause a drop in line voltage, resulting in overheating and loss of power. Use the chart to determine the minimum wire size required in an extension cord. Only round jacketed cords listed by Underwriter's Laboratories (UL) should be used.

When working outdoors with a tool, use an extension cord that is designed for outside use. This type of cord is designated with "WA" on the cord's jacket.

Before using any extension cord, inspect it for loose or exposed wires and cut or worn insulation.

**Ampere rating
(on tool faceplate) 0-2.0 2.1-3.4 3.5-5.0 5.1-7.0 7.1-12.0 12.1-16.0

Cord Length	Wire Size (A.W.G.)					
25'	16	16	16	16	14	14
50'	16	16	16	14	14	12
100'	16	16	14	12	10	—

****Used on 12 gage - 20 amp circuit.**

WARNING:

Keep the extension cord clear of the working area. Position the cord so that it will not become caught on lumber, tools or other obstructions while you are working with a power tool. Failure to do so can result in serious personal injury.

WARNING:

Check extension cords before each use. If damaged replace immediately. Never use tool with a damaged cord since touching the damaged area could cause electrical shock resulting in serious injury.

FEATURES

PRODUCT SPECIFICATIONS

Input	120 V, 60 Hz, AC Only, 5.5 A
No Load Speed	0-3,200 r/min. (RPM)
Stroke Length.....	1 in.
Maximum Cutting Depth in Wood.....	3 in.
Orbital Settings	4
Laser Guide	Class IIIa, <5mW max, 650 nm
Net Weight.....	6 lbs.

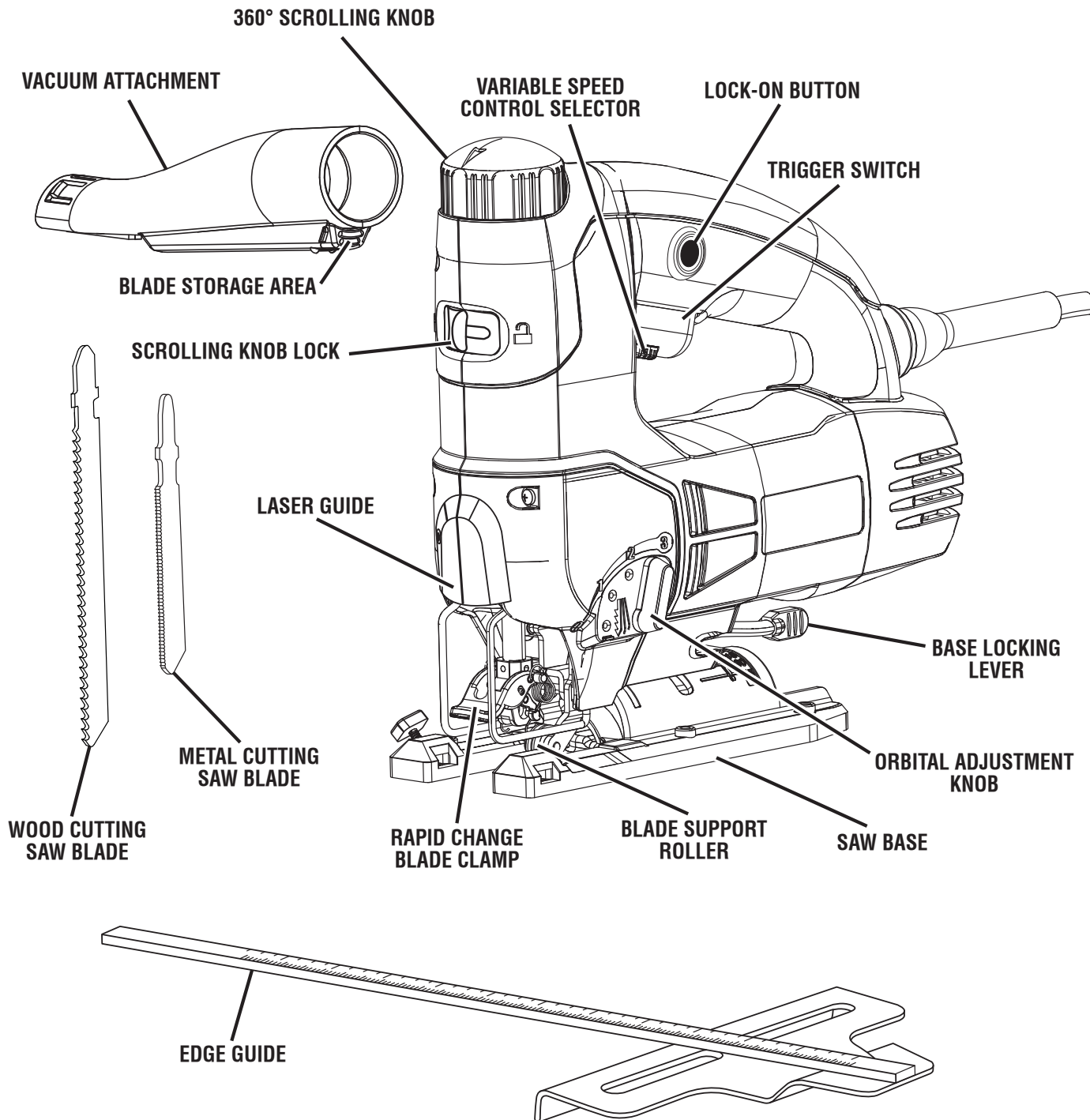

Fig. 1

FEATURES

KNOW YOUR JIG SAW

See Figure 1.

Before attempting to use this product, familiarize yourself with all operating Features and Safety Rules.

SWITCH

The jig saw has a conveniently located trigger switch.

VARIABLE SPEED CONTROL SELECTOR

The trigger switch has a variable speed control selector to adjust the speed of the jig saw.

LOCK-ON BUTTON

The lock-on button allows continuous operation.

LASER GUIDE

The laser guide projects a red line on your workpiece to give you a straight line to follow.

BASE LOCKING LEVER

Toolless saw base adjustment makes bevel adjustment for adjusting the cut angle quick and easy.

BLADE SUPPORT ROLLER

The blade support roller reduces blade flexing to ensure accurate cutting.

ORBITAL ADJUSTMENT KNOB

Four position orbital adjustment for fine to aggressive cutting.

VACUUM ATTACHMENT / BLADE STORAGE

A vacuum attachment is packed with your saw. Used in conjunction with a vacuum cleaner, it will yield the highest dust removal efficiency. It features a built-in blade storage area.

SCROLLING KNOB

360° scrolling blade action for precision cutting in tight areas.

RAPID CHANGE BLADE CLAMP

Allows you to change saw blades without the need for separate tools.

EDGE GUIDE

Allows you to make straight cuts using the edge of the workpiece as a guide.

UNPACKING

This tool has been shipped completely assembled except for the blade.

- Carefully remove the tool and accessories from the box.
- Make sure that all items listed in the packing list are included.
- Inspect the tool carefully to make sure no breakage or damage occurred during shipping.
- Do not discard the packing material until you have carefully inspected and satisfactorily operated the tool.
- If any parts are damaged or missing, please call 1-800-525-2579 for assistance.

PACKING LIST

Variable Speed Orbital Jig Saw
Blades (2)
Vacuum Attachment
Edge Guide
Case
Operator's Manual

WARNING:

If any parts are missing do not operate your tool until the missing parts are replaced. Failure to do so could result in possible serious personal injury.

ASSEMBLY

WARNING:

Do not connect to power supply until assembly is complete. Failure to comply could result in accidental starting and possible serious personal injury.

TO INSTALL JIG SAW BLADES

See Figure 2.

- Unplug your saw.
- Lift the clamping lever on the rapid-change blade clamp until it stops.
- Holding the clamping lever up, insert the saw blade as far as possible into the slot in the saw bar.
- Check to make sure the back of the saw blade is centered in the groove of the roller guide.
- Release the clamping lever. Make sure the blade is securely in place.

DUST PICK-UP FEATURE

See Figure 3.

For dust pick-up operation, a vacuum attachment has been provided with the saw. It attaches to the saw base.

To Install:

- Unplug the saw.
- Slide the vacuum attachment into the curved area at the rear of the saw base until it snaps into place.
- Attach vacuum attachment to a 1-1/4 in. vacuum hose.
- Connect vacuum hose to cleaner.

To Remove:

- Unplug the saw.
- Remove the vacuum attachment by pulling attachment from base.

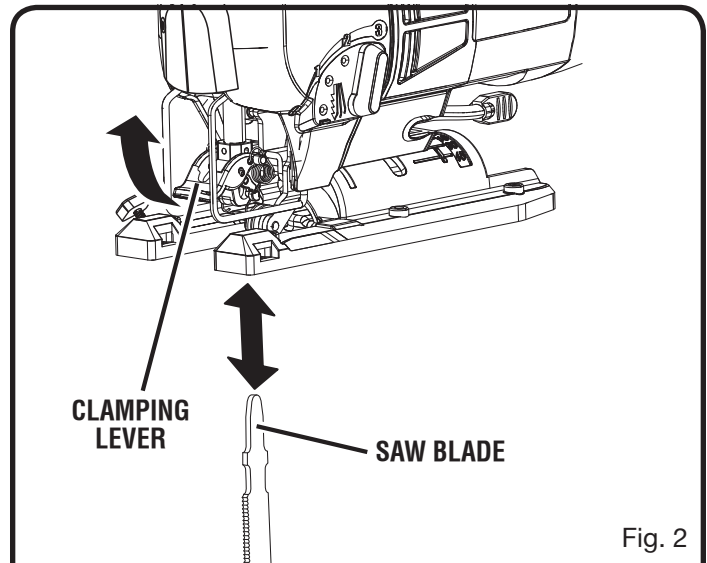

Fig. 2

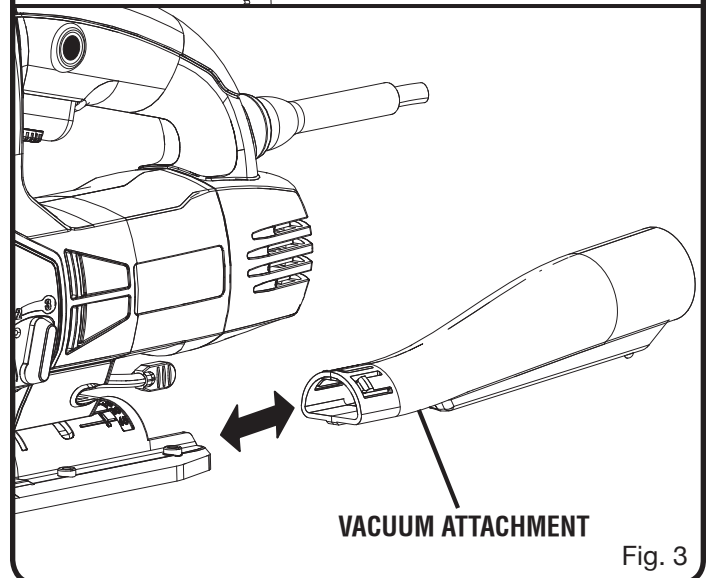

Fig. 3

OPERATION

⚠ WARNING:

Do not allow familiarity with your tool to make you careless. Remember that a careless fraction of a second is sufficient to inflict severe injury.

⚠ WARNING:

Always wear safety goggles or safety glasses with side shields when operating this tool. Failure to do so could result in objects being thrown into your eyes, resulting in possible serious injury.

APPLICATIONS

You may use the jig saw for the purposes listed below:

- Sawing non-ferrous metal, sheet steel, wood, plastic, and similar materials.

SWITCH

See Figure 4.

To turn the saw ON, depress the trigger switch. Release trigger switch to turn the saw OFF.

LOCK-ON BUTTON

See Figure 4.

The saw is equipped with a lock-on feature, which is convenient when continuous cutting for extended periods of time is required. To lock-on, depress the trigger switch, push in and hold the lock-on button located on the side of the handle, then release trigger switch. Release lock-on button and your saw will continue running.

To release the lock, depress the trigger switch and release.

If you have the lock-on feature engaged during use and your saw becomes disconnected from power supply, disengage the lock-on feature immediately.

⚠ WARNING:

Before connecting the saw to power supply, always check to be sure it is not in lock-on position (depress and release trigger switch). Failure to comply could result in accidental starting and possible serious injury. Also, do not lock the trigger on jobs where the saw may need to be stopped suddenly.

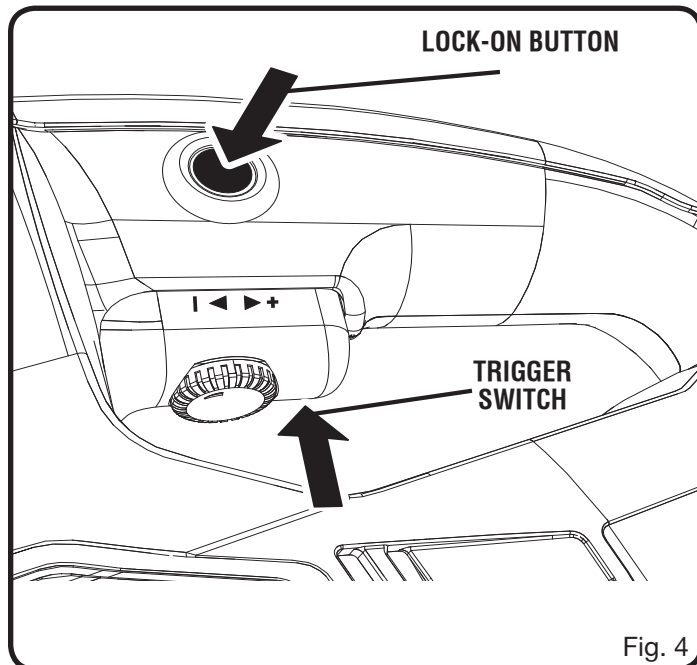

Fig. 4

OPERATION

VARIABLE SPEED

See Figure 5.

The saw has a variable speed control selector designed to allow operator control and adjustment of speed and power limits. The speed and power of your saw can be increased or decreased by rotating the variable speed control selector in the direction of the arrows shown in figure 5.

NOTE: Hold the saw in normal operating position and turn the variable speed control selector to the positive symbol to increase speed and power. Turn to the negative symbol to decrease speed and power.

If you desire to lock the switch on at a given speed, depress the trigger switch, push in and hold the lock-on button, and release the trigger switch. Next, adjust the variable speed control selector until the desired speed is reached.

Avoid running your saw at low speeds for extended periods of time. Running at low speeds under constant usage may cause your saw to become overheated. If this occurs, cool your saw by running it without a load and at full speed.

The following guidelines may be used in determining correct speed for various applications:

LOW speed is ideal when minimum speed and power is required, for example, starting cuts.

MEDIUM speed is suitable for cutting hard metals, plastics, and laminates.

HIGH speed produces best results when maximum power is required, for example, cutting wood. Soft metals such as aluminum, brass, and copper may also require high speeds.

WARNING:

Do not insert saw blade into air vents. They could come in contact with electrically live internal parts, and cause electrical shock resulting in serious injury.

GENERAL CUTTING

Rest the front of the saw base on the workpiece and align cutting edge of the blade with the line on your workpiece. Make sure the power cord is out of your way and not in the line of cut. Start your saw and move it forward on the work surface. Apply downward pressure to keep the saw steady and only enough forward pressure to keep the blade cutting.

DO NOT FORCE THE SAW

Applying too much forward pressure your saw may overheat the motor and break saw blades.

ORBITAL MOTION

See Figure 6.

The blade of the saw cuts in an orbital motion. This feature is adjustable and provides faster, more efficient cutting. With orbital motion the blade cuts through your work in the upstroke but does not drag across your work in the downstroke. The higher settings should be used when fast

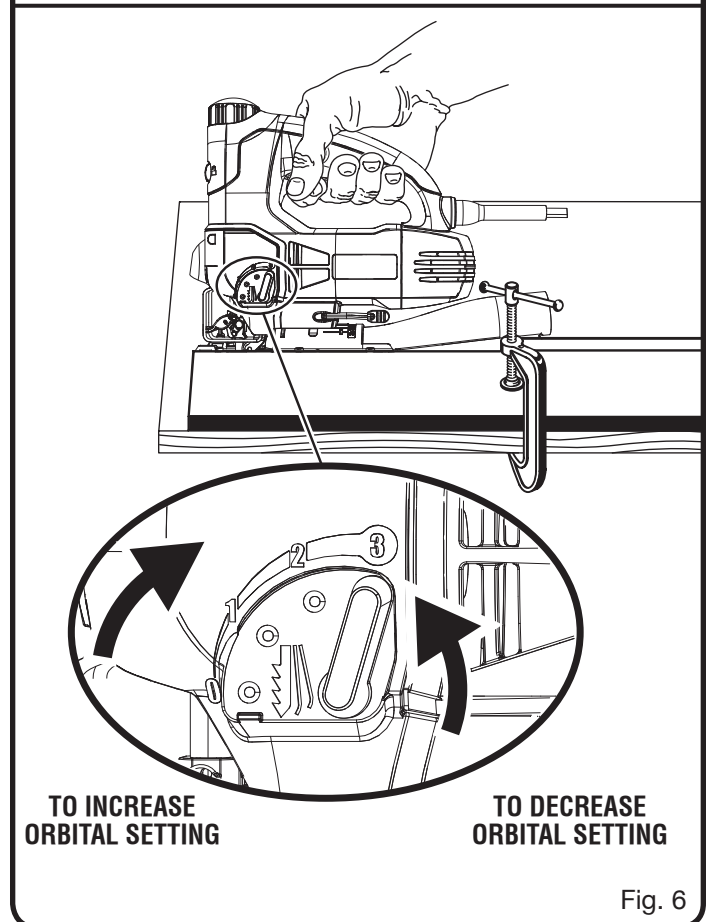
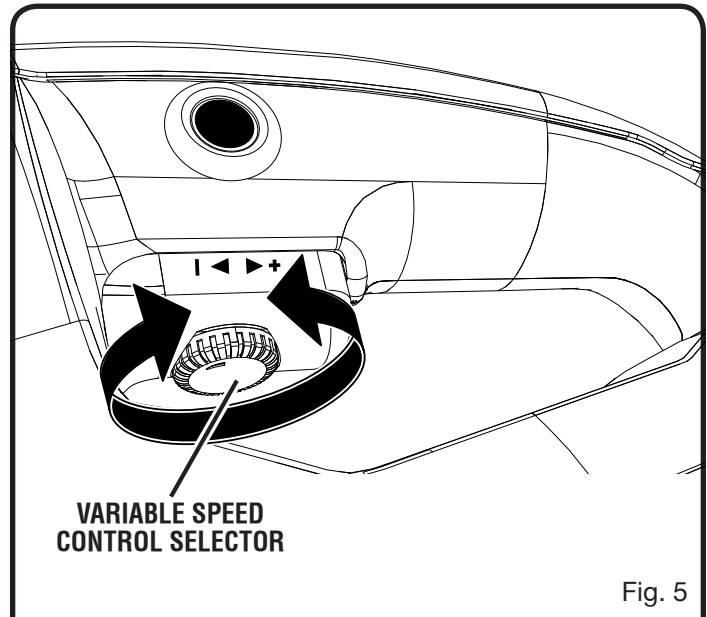

cutting in soft material is desired. The lower settings should be used when cutting materials with more resistance. The "0" setting shuts off the orbital motion. Setting "3" offers the maximum orbital motion.

OPERATION

STRAIGHT CUT

See Figures 7 - 9.

Your saw is equipped with a lock for locking the scrolling knob in the forward facing position. This should be locked for all straight cuts as shown in figure 8. A straight cut can be made by clamping a piece of wood or straightedge to the workpiece and guiding the edge of the saw against it. Make the cut from one direction only. Don't cut halfway and complete the cut from the opposite end. You can also use the supplied edge guide as shown in figure 8. Loosen the thumb screw and insert the end of the edge guide through the two slots in the base. Measure the distance to cut and tighten the thumb screw. Place the edge guide on the outside edge of the workpiece and cut in a straight path.

⚠ WARNING:

To avoid possible serious injury, keep hands and fingers from between the gear housing and saw blade clamp, and keep the guard in place.

⚠ WARNING:

Excessive side pressure to the blade could result in broken blades or damage to the material being cut.

USING THE LASER GUIDE

See Figure 9.

⚠ WARNING:

Do not stare into the laser beam or turn the laser on when the tool is not in use. Failure to do so could result in possible serious personal injury. The laser unit comes from the factory already installed and aligned. If the laser becomes misaligned after time refer to the "Adjustments" section.

The jig saw is equipped with a laser guide to project a red line to show the cut path.

- Pull the switch trigger slightly to engage the laser guide.
- The laser guide will turn on before the jig saw and continue to stay on for the cutting operation.
- The laser guide will turn off when the switch trigger is released.

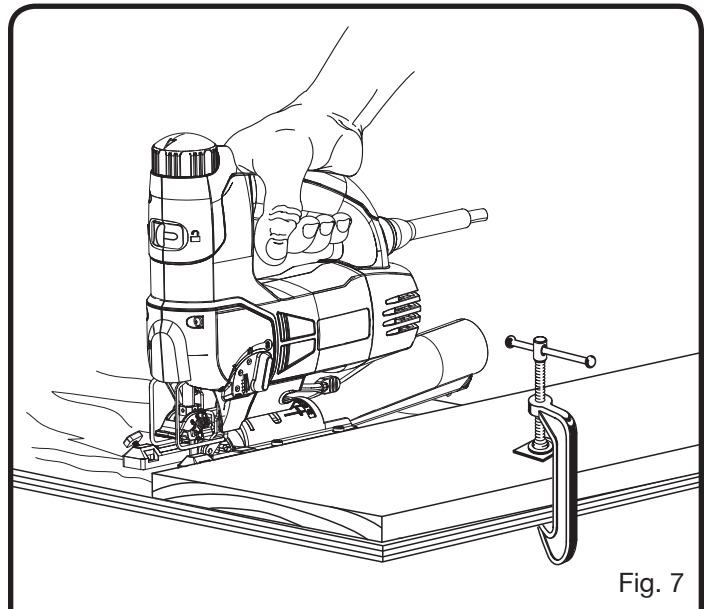

Fig. 7

SCROLLING
KNOB LOCK

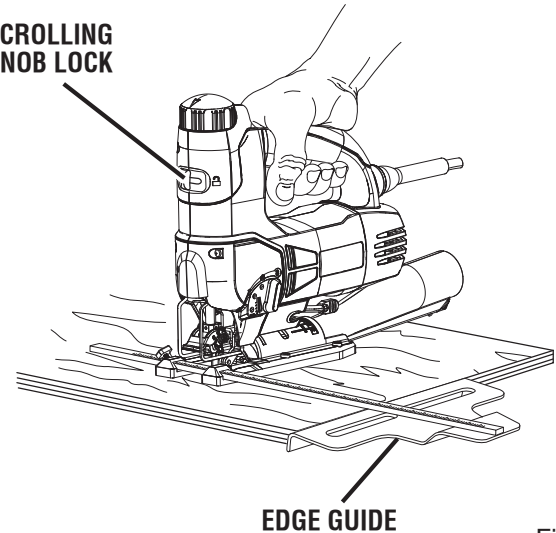

Fig. 8

LASER GUIDE

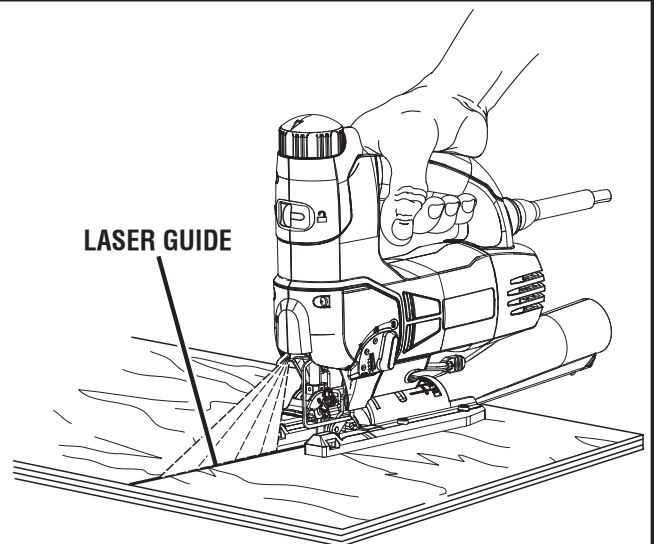

Fig. 9

OPERATION

SCROLL CUTTING

See Figures 10, 11, and 12.

The scroll cutting feature is designed to permit 360° rotation of the saw blade so that intricate designs may be cut with minimum effort.

- Set the orbit adjustment to “0”.
- Loosen the base locking lever as shown in figure 10.
- Slide the base back to move the blade-support roller out of the way of the saw blade as shown in figure 11.
- Retighten the base locking lever.
- Unlock the scrolling mechanism of your saw by sliding the scrolling knob lock, located on the front of the jig saw, to the right.
- Rotate the scrolling mechanism with your free hand as you apply pressure in the direction of the cut with your other hand as shown in figure 12.

NOTE: The laser guide will not rotate with the scrolling mechanism.

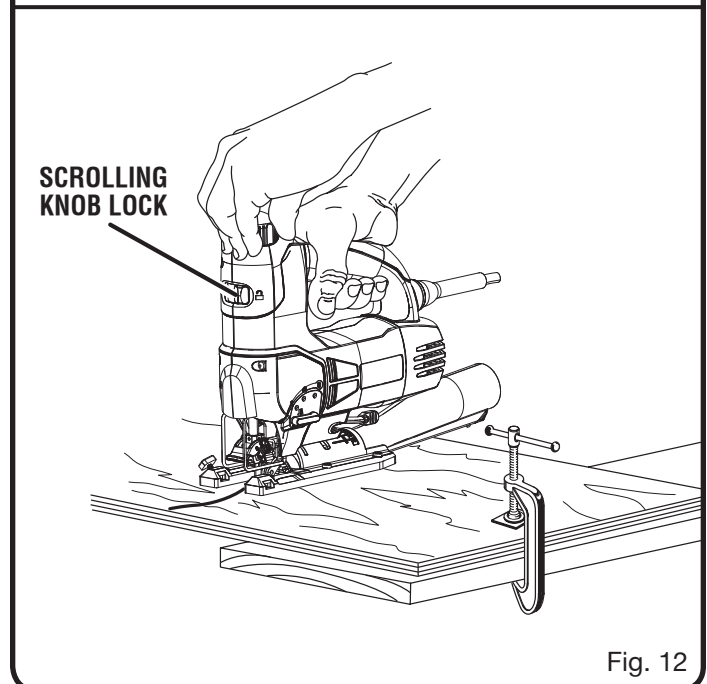
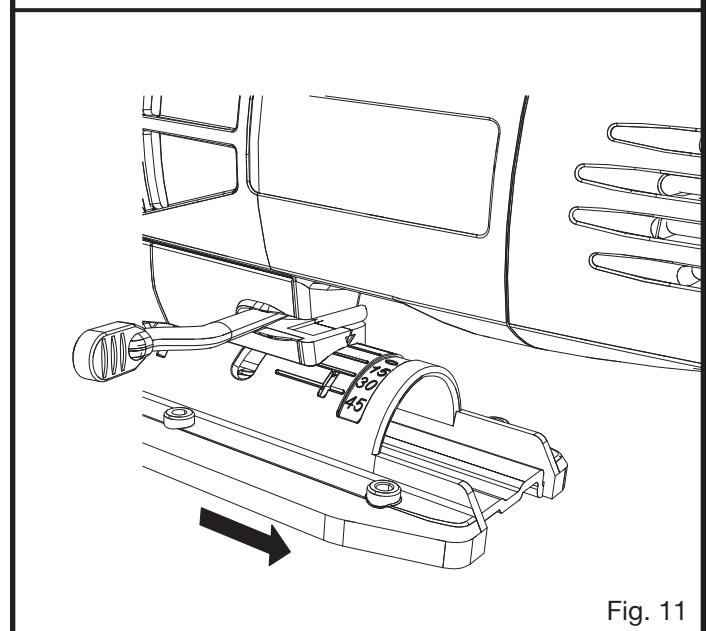
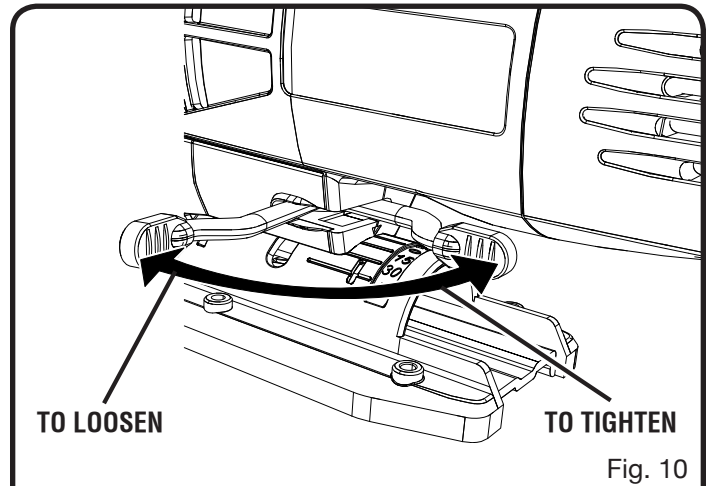

OPERATION

ANGLE CUTTING (BEVEL CUTTING)

See Figures 13 and 14.

Bevel cutting angles may be adjusted from 0° to 45° right or left. Angles for cuts from 0° to 45° in 15° increments are marked on a scale on both the left and right side of the base. An arrow under the motor assembly provides an indicator at each of the above mentioned 15° increments. A protractor is recommended when accurate cuts are required.

- Unlock the base by moving the base locking lever forward.
- Align the mark, on the base, of the desired angle with the indication arrow located on the housing.
- Once the desired angle is reached, tighten the base locking lever by moving the base locking lever under the motor assembly.

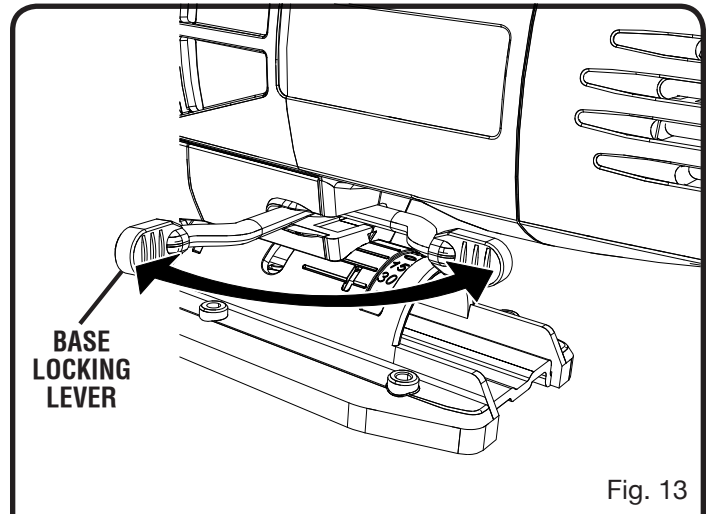

Fig. 13

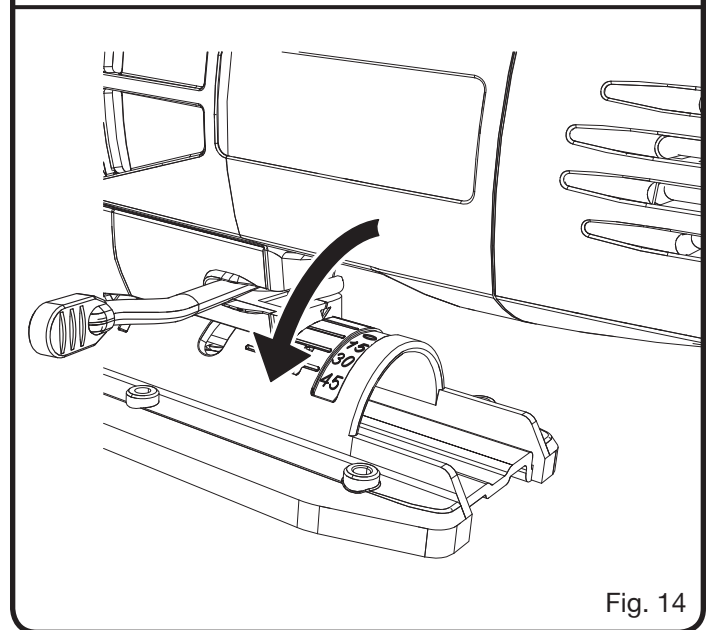

Fig. 14

OPERATION

PLUNGE CUTTING

See Figures 15, 16, and 17.

⚠ WARNING:

To avoid loss of control, broken blades, or damage to the material being cut, always use extreme caution when making plunge cuts. We do not recommend plunge cutting on materials other than wood.

TO MAKE A PLUNGE CUT

- Mark the line of cut clearly on the workpiece.
- Set the orbit adjustment to "0".
- Tilt the saw forward so that it rests on the front edge of the base and blade will not come in contact with the workpiece when the saw is turned on.
- Make sure the blade is inside the area to be cut.
- Using high speed, start the saw and slowly lower the blade into the workpiece until the blade cuts through the wood.
- Continue lowering the blade into the workpiece until the base rests flat on the work surface, then move the saw forward to complete the opening.
- Use only the 7 teeth per inch blade for this type of cut.

METAL CUTTING

NOTE: The jig saw has to be in the no-orbit mode to cut metals and conduit. Set the orbital adjustment knob to "0".

Many kinds of metals can be cut with the saw. Be careful not to twist or bend the blades. Do not force. If the blade chatters or vibrates excessively, use a finer-tooth metal-cutting blade. If blade heats excessively, use lower speed. If blade teeth become filled or clogged when cutting soft metals, such as aluminum, use a coarser-tooth blade or lower speed. We recommend use of oil when cutting metals to keep blades cool, increase cutting action, and prolong blade life. Clamp the work firmly and saw close to the clamping point to eliminate any vibration of the work being cut.

When cutting conduit, pipe or angle iron, clamp work in a vise if possible and saw close to the vise. To cut thin sheet materials, "sandwich" the material between hardboard or plywood and clamp the layers to eliminate vibration and material tearing. By doing this, the material will be cut smoothly. Lay out your pattern or line of cut on top of the "sandwich."

NOTE: When cutting metal, keep exposed portion of saw bar clean and free of metal chips by wiping frequently with an oily cloth. Use extreme caution in disposing of oily cloth after completion of job to prevent potential fire hazard.

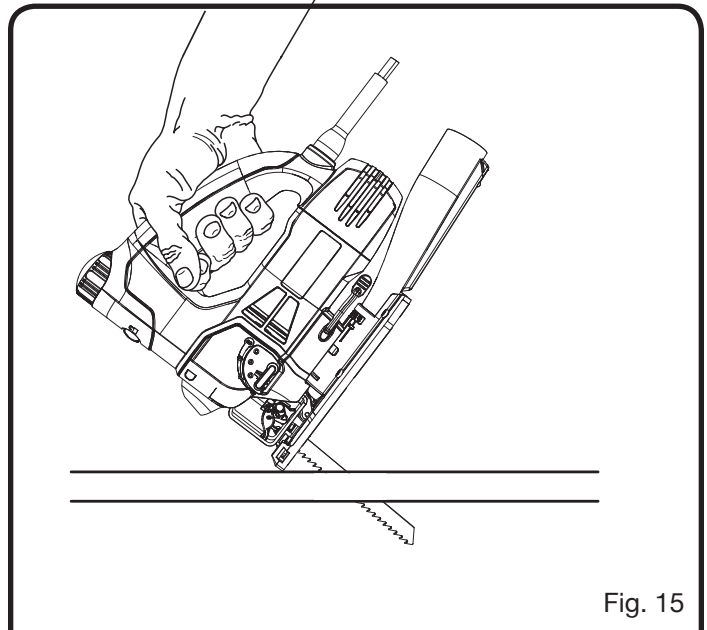

Fig. 15

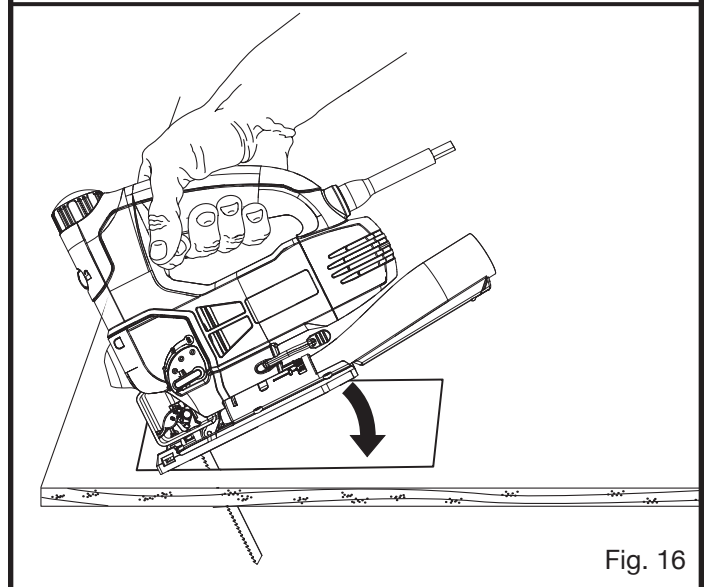

Fig. 16

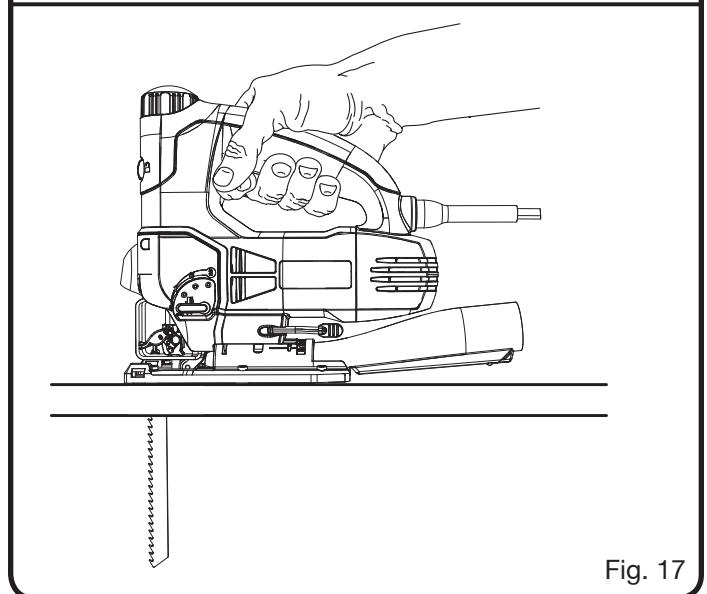

Fig. 17

ADJUSTMENTS

⚠ WARNING:

Before performing any adjustment, make sure the tool is unplugged from the power supply and the switch is in the OFF position. Failure to heed this warning could result in serious personal injury.

BASE LOCKING LEVER ADJUSTMENT

See Figures 18 and 19.

The base locking lever may need occasional adjustment. It may be necessary to tighten the lever.

- Unplug the saw.
- If attached, remove the vacuum attachment.
- Remove the base plate screws and base plate by removing the six base screws to expose the adjusting nut.
- Loosen the locking screw. It is not necessary to remove the screw from the base.
- Release the base locking lever by pulling it forward.
- Tighten the adjusting nut 1/4 of a turn in the clockwise direction.
- Engage the lock lever by pushing it back under the motor assembly and check the base for any movement.
- If the base is still loose, release the lock lever and tighten the adjusting nut another 1/4 of a turn. Repeat until the base is secure after engaging the lock lever.
- Securely tighten the locking screw. This will keep the adjusting nut from coming loose.
- Install the base plate and all base plate screws.

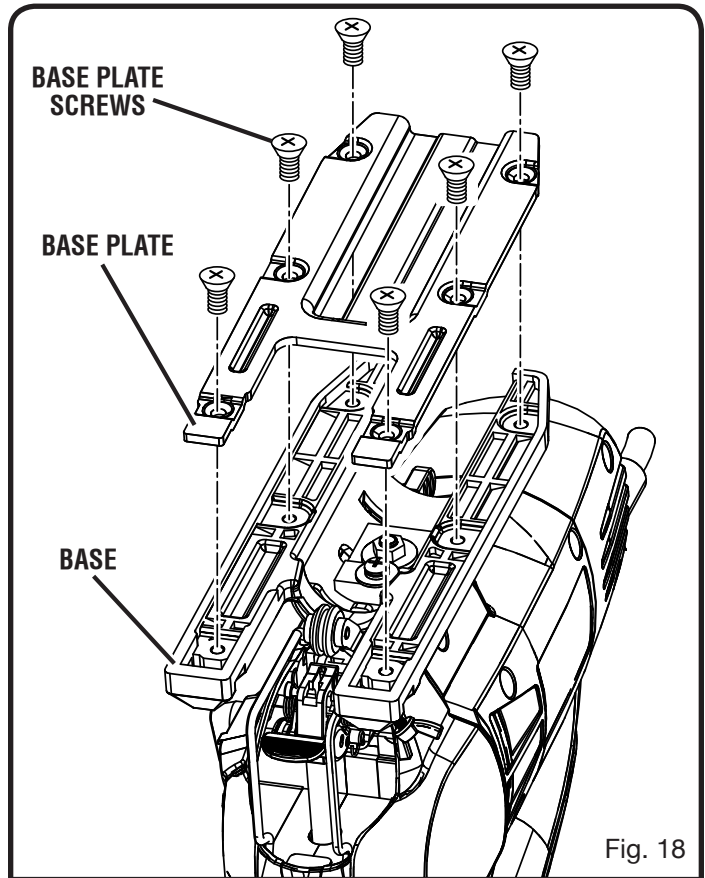

Fig. 18

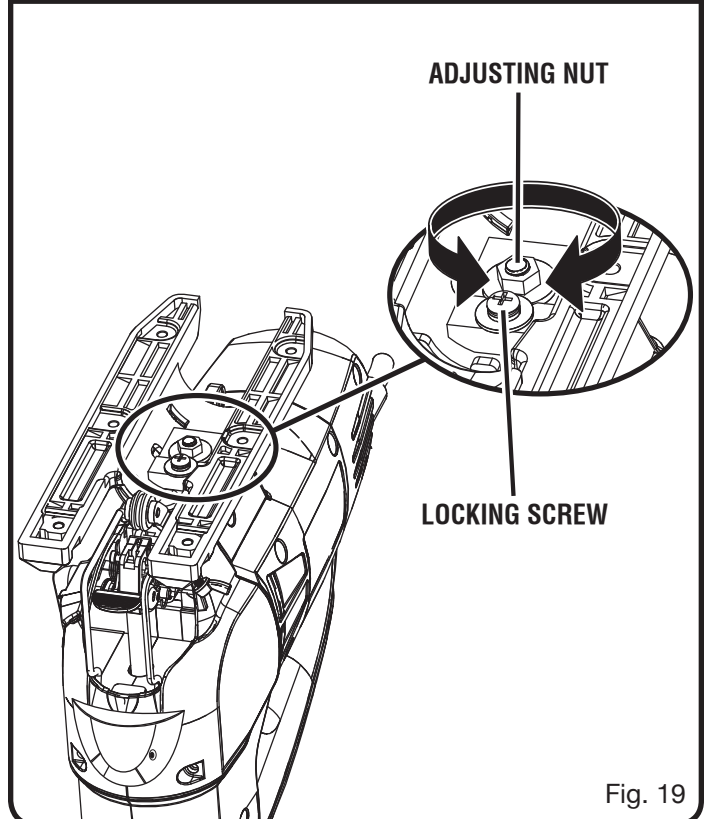

Fig. 19

ADJUSTMENTS

LASER GUIDE ADJUSTMENT

See Figure 20.

NOTE: Draw a pencil line on a scrap workpiece parallel to the long edge of the base as a straight line guide to aid in the adjusting process.

- Unplug the jig saw.



WARNING:

Failure to unplug your saw could result in accidental starting causing possible serious personal injury.

- If the laser guide is on the right side of the line, turn the laser adjustment screw counter clockwise one half of a turn.
- If the laser guide is on the left side of the line, turn the laser adjustment screw clockwise one half of a turn.
- Plug saw into power supply.
- Pull the switch trigger just enough to light the laser guide to check for position.
- Repeat above steps if necessary.

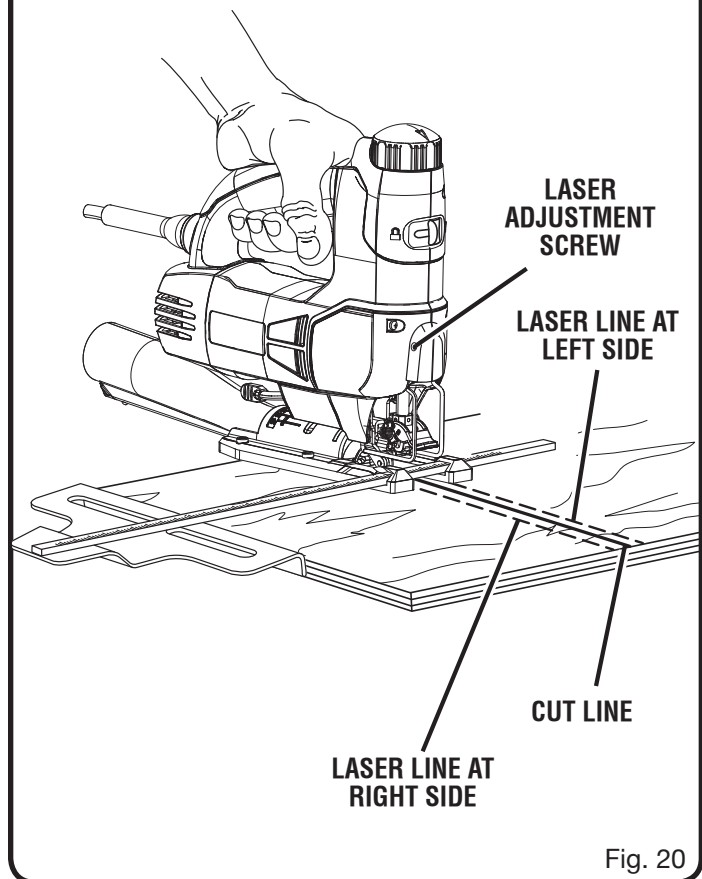

Fig. 20

MAINTENANCE

 **WARNING:**

When servicing use only identical Ryobi replacement parts. Use of any other parts may create a hazard or cause product damage.

 **WARNING:**

Always wear safety goggles or safety glasses with side shields during power tool operation or when blowing dust. If operation is dusty, also wear a dust mask.

 **WARNING:**

Do not at any time let brake fluids, gasoline, petroleum-based products, penetrating oils, etc. come in contact with plastic parts. Chemicals can damage, weaken, or destroy plastic, which may result in serious personal injury.

GENERAL MAINTENANCE

Avoid using solvents when cleaning plastic parts. Most plastics are susceptible to damage from various types of commercial solvents and may be damaged by their use. Use clean cloths to remove dirt, carbon dust, etc.

Electric tools used on fiberglass material, wallboard, spackling compounds, or plaster are subject to accelerated wear and possible premature failure because the fiberglass chips and grindings are highly abrasive to bearings, brushes, commutators, etc. Consequently, we do not recommend using this tool for extended work on these types of materials. However, if you do work with any of these materials, it is extremely important to clean the tool using compressed air.

LUBRICATION

All of the bearings in this tool are lubricated with a sufficient amount of high grade lubricant for the life of the tool under normal operating conditions. Therefore, no further lubrication is required.



OPERATOR'S MANUAL

Orbital Scrolling Jig Saw with Laser JS550L

- **SERVICE**

Now that you have purchased your tool, should a need ever exist for repair parts or service, simply contact your nearest Authorized Service Center. Be sure to provide all pertinent facts when you call or visit. Please call 1-800-525-2579 for your nearest Authorized Service Center. You can also check our web site at www.ryobitools.com for a complete list of Authorized Service Centers.

- **MODEL NO. AND SERIAL NO.**

The model number of this tool will be found on a plate attached to the motor housing. Please record the model number and serial number in the space provided below.

- **HOW TO ORDER REPAIR PARTS**

When ordering repair parts, always give the following information:

- MODEL NUMBER _____ JS550L _____
- SERIAL NUMBER _____ _____

Ryobi® is a registered trademark of Ryobi Limited used under license.

ONE WORLD TECHNOLOGIES, INC.

1428 Pearman Dairy Road, Anderson, SC 29625

Phone 1-800-525-2579

www.ryobitools.com