

# Home Decorators

—Collection—











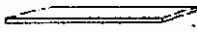





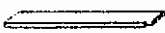
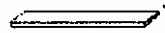



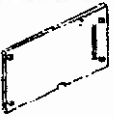
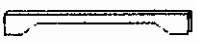
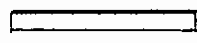

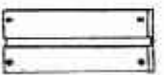

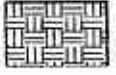
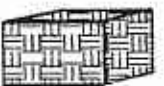

BF-21081 Oxford Bench Wicker Storage 20"Hx60"W

## ASSEMBLY INSTRUCTIONS

Made In China-1A

Thank you for purchasing this quality product. Be sure to check all packing material carefully for small parts, which may have come loose inside the carton during shipment. Count all parts and material hardware. Compare with parts list to be sure all parts are present. If any parts are missing or damaged, phone, fax, or mail to our Customer Service Department. For efficient and speedy service please indicate the model number and code letter of part (s) need.

**IMPORTANT NOTE:** Follow instructions listed below in proper sequence as numbered to assure fast, easy and correct assembly.

PARTS LIST					
A  TOP PANEL-1PC	B  BOTTOM PANEL-1PC	C  LEFT SIDE PANEL-1PC	D  RIGHT SIDE PANEL-1PC	E  LEFT ACROSS PANEL-1PC	E1  MIDDLE ACROSS PANEL-1PC
F  MIDDLE ACROSS PANEL 1PC	G  RIGHT ACROSS PANEL 1PC	H  BACK PANEL-2PCS	I  ADORN PANEL-1PC	J  LEFT STAND PANEL-1PC	J1  MIDDLE STAND PANEL-1PC
K  RIGHT STAND PANEL-1PC	N  FRONT LOW PANEL-2PCS	M  BACK LOW PANEL-1PC	L  FRONT DRAWER PANEL-4PCS	O  SIDE DRAWER PANEL-8PCS	
P  BACK DRAWER PANEL-4PCS	Q  BASE DRAWER PANEL-4PCS	R  BASE WICKER BASKET-4PCS	S  SIDE FRAME WICKER BASKET-4PCS	T  HANDLE KNOB-4PCS	
U  SCREW-26PCS	V  CAM-LOCKS-30PCS	W  CAM-BOLTS-30PCS	X  SCREWS-4PCS	Y  DOWELS-22PCS	
Z  SCREWS-16PCS	A1  SCREWS-37PCS	B1  SCREWS-4PCS	C1  CAM-TOOL-1PC	D1  SEAT-1PC	

**NOTE:** Upon opening thoroughly clean all woods surfaces with furniture polish to remove dust and dirt that may have settled onto finish during shipment in order to protecting the product. Please assemble the product with at least two people.

### 1.) Assemble the drawer

Rotate the screws (A1) through the holes of side drawer panel (O) into the front drawer panel (L). Insert the base drawer panel (Q) through the slot of side panel (O) into the front drawer panel (L), and then rotate the screws (A1) through the holes of side drawer panel (O) into the back drawer panel (P). Rotate the screws (B1) through the middle holes of front panel (L) into the knob (T). (See the right picture)

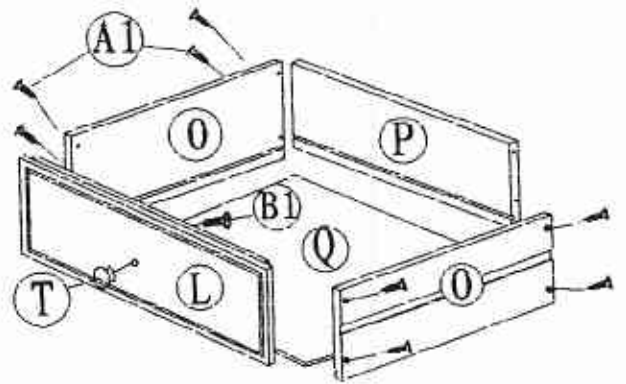

### 2.) Assemble stand panel (J/J1/K) and left/right/middle across panel (E/G/E1/F).

Insert the dowel (Y) into the holes of across panel (E/E1/F/G). Use the cam-tool (C1) rotate the cam-bolts (W) into the holes of stand panel (J/J1/K) and attach across panel (E/E1/F/G). Then use the cam-tool (C1) tightens the cam-locks (V) clockwise into across panel (E/E1/F/G). (See the right picture).

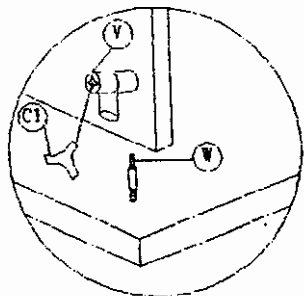
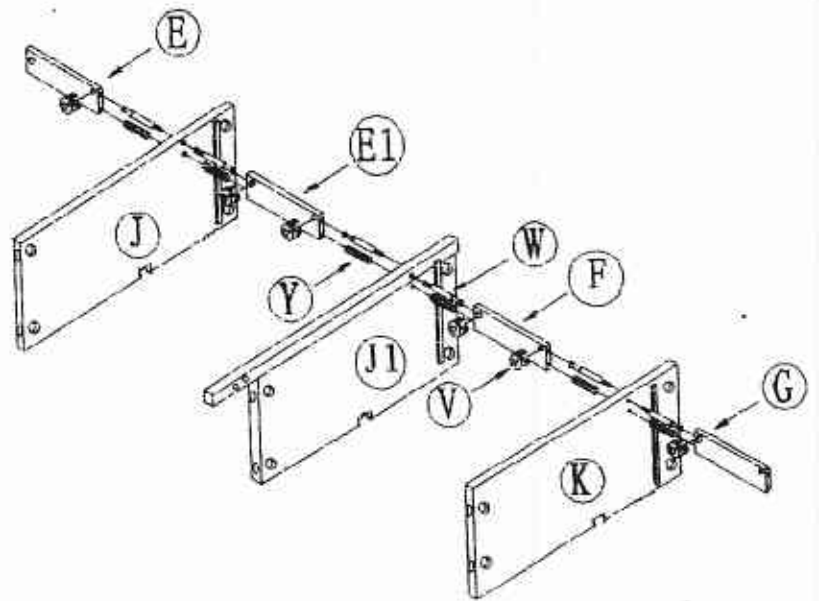

How to use CAM-TOOT

### 3.) Assemble the bottom panel (B).

Use the cam-tool (C1) rotate the cam-bolts (W) into the bottom panel (B) and attach stand panel (J/J1/K), then use the cam-tool (C1) tighten the cam-locks (V) clockwise into the holes of stand panel (J/J1/K). (See the right picture).

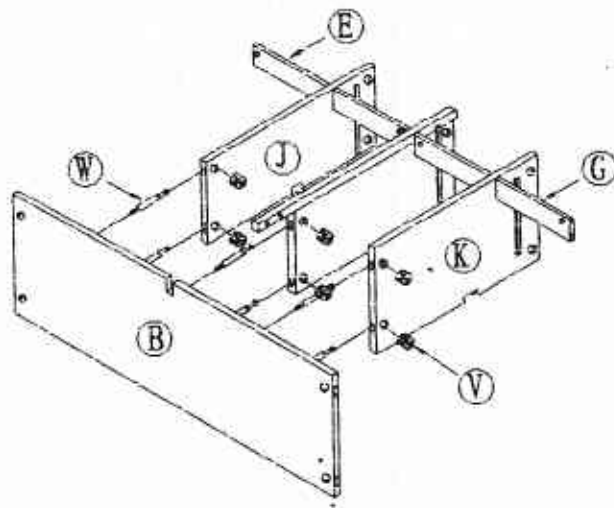

### 4.) Assemble the side panel (C/D) and front/back low panel (N/M).

Insert the dowel (Y) into the front/back low panel (N/M) and across panel (E/G). Use the cam-tool (C1) rotate the cam-bolts (W) into the side panel (C/D) and attach the front/back low panel (N/M) and across panel (E/G). Then use the cam-tool (C1) tightens the cam-locks (V) clockwise into the bottom panel (B) and back low panel (M) and across panel (E/G). Finally, rotate the screws (X) through the holes of front/back low panel (N/M) into the bottom panel (B). (see the left picture).

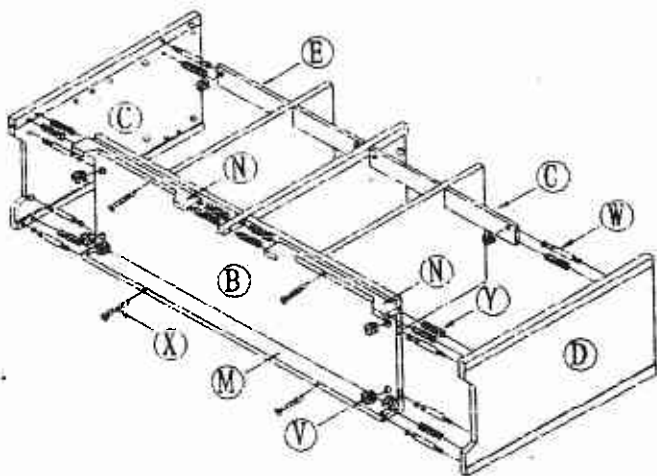

### 5) Assemble the top panel (A).

Use the cam-tool (C1) rotates the cam-bolts (W) into the top panel (A) and attaches the side panel (C/D) and stand panel (J/J1/K). Then use the cam-tool (C1) tightens the cam-lock (V) clockwise into the side panel (C/D) and stand panel (J/J1/K). (See the right picture).

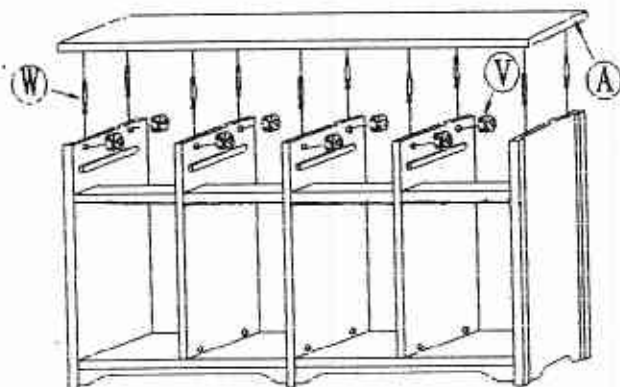

### 6.) Assemble the back panel (H) and the wicker basket

Rotate the screws (A1) through the holes of adorn panel (I) into the side panel(C/D). Then insert two pieces of back panel (H) into the slot of adorn panel (I) and with screws (U) to tighten them; rotate the screws (Z) through the holes of side frame wicker basket (S) into the base the wicker basket(R) and put the wicker basket between in the side/stand panel. Finally, push the drawer into the wood glide and insert the dowel (Y) into the holes of top panel (A).(See the right picture).

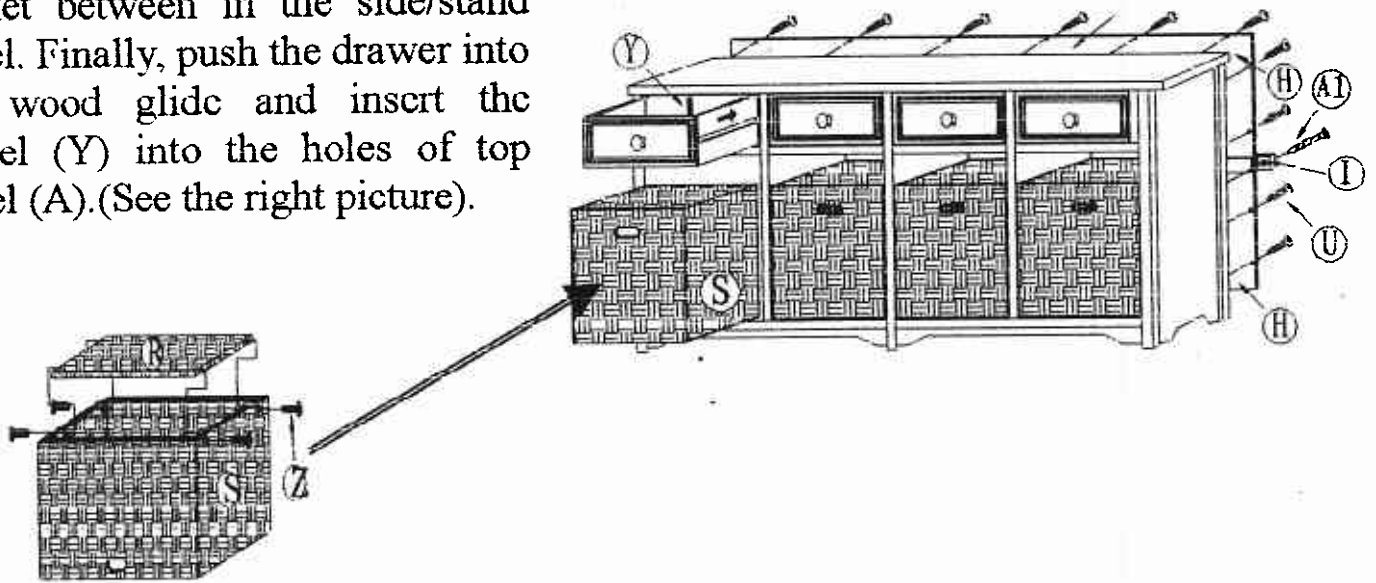

### 7). Put the seat (D1) onto the top panel .Ok! (See the below picture)

