

Masonry Anchor

Model # - MA250US

Installation Instructions

Step 1

Place post in the desired position.

Step 2

Using the holes in the flange as a guide, start drilling four 3/8" diameter holes using a 3/8" masonry drill bit. Drill the holes approximately 1/2" deep. Remove the post and complete drilling the four holes in the concrete to a depth of 2" - 2-1/4".

Step 3

Remove the nuts from the four masonry anchors, insert the anchors through the holes in the flange from the bottom and replace the nuts. Screw the nuts on so that they sit slightly above the top of the threaded masonry anchors.

Step 4

Reposition the post and use a hammer to tap the masonry anchors into the holes in the concrete. Tap on the nuts until the anchors are completely seated in the holes with the flange flat on the concrete.

Step 5

Use an adjustable wrench to tighten the nuts.

Tools Required

- Drill
- 3/8" masonry drill bit
- Hammer
- Adjustable wrench

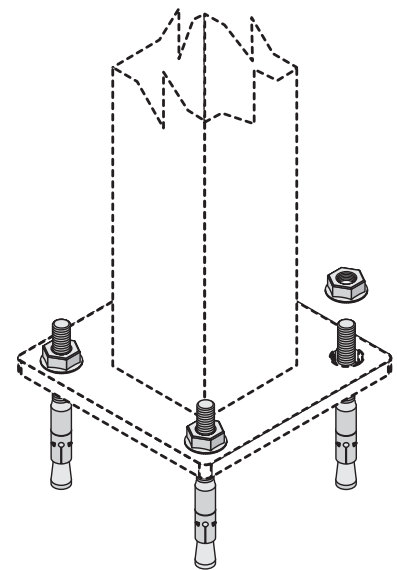
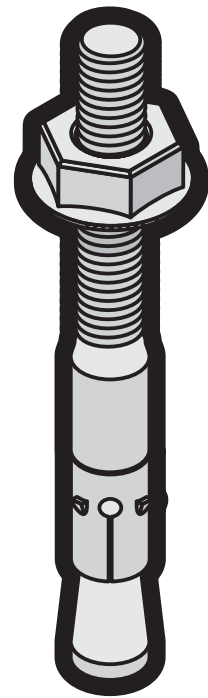

fig. 1



U.S. Door and Fence, LLC., 3880 Garner Road, Riverside CA 92501-1066

For questions, please contact by phone(951)300-0010 or fax (951)300-0016

For warranty information, please contact warranty@usdoorfence.com