

GoWISEUSA®

Instruction Manual

ELECTRIC AIR FRYER
GW22731/GW22735/GW22743/GW22746



WWW.GOWISEUSA.COM

Table of Contents

Product Introduction	3
Important Safeguards.....	4
Electromagnetic Fields	6
Product Structure and Features.....	7
Before First Use	9
How to Use Your Air Fryer	10
Cooking Guide.....	15
Cleaning Your Air Fryer.....	17
Troubleshooting	18
Warranty.....	19

Product Introduction

GoWISE USA would like to introduce the GW22731 (Black), GW22735 (White), GW22745 (Red), and GW22746 (Plum) Air Fryers with Rapid Air Technology. Rapid Air Technology is a new technique for preparing food that traditionally needs to be dunked in oil and fried. Rapid Air Technology works by quickly circulating hot air around the Air Fryer pan. The best part—it heats food in all directions and most dishes cook with little to no oil.

This is a 5.8-quart air fryer with 8 built-in smart programs including Fries, Pork, Shrimp, Cake, Chicken, Steak, Fish, and Pizza. It offers a wide temperature range from 180F-400F and a cooking timer for up to 30 minutes. Plus an alarm that can be set to 5, 10 or 15 minutes, to remind you to check what's cooking. Air frying offers a healthier and easier way to cook, and in 30 minutes or less.

Important Safeguards

1. READ THE ENTIRE MANUAL BEFORE ATTEMPTING TO OPERATE.
2. Keep the box and packing material for storage.
3. Do not immerse the cord, plug, or any part of the appliance in water or any other liquids to avoid electric shock.
4. Keep all the ingredients in the basket to prevent any contact from heating elements.
5. Do not cover the air inlet and air outlet when the appliance is on.
6. Do not fill the pan with oil. Filling the pan with oil may cause a fire hazard.
7. Do not touch the inside of the appliance while it is operating.
8. Do not use the appliance if there is any damage to the plug, main cord, or other parts.
9. Do not go to any unauthorized person to replace or fix the appliance.
10. keep the main cord away from hot surface.
11. Do not plug the appliance or use the appliance with wet hands.
12. Make sure that the appliance is plugged into the wall socket properly.
13. Make sure that the appliance is out of reach of children, especially when the fryer is operating.
14. Do not connect the appliance to an external timer switch.
15. Do not place the appliance on or near combustible materials, such as a tablecloth or curtain.

Important Safeguards - Continued

16. Do not place the appliance against a wall or any other appliances. Leave at least 5 inches of free space on the back, sides, and above the appliance.
17. Do not place anything on top of the appliance.
18. Do not use the appliance for any other purposes other than described in this manual.
19. Do not leave the appliance unattended while it is operating.
20. During hot air frying, hot steam is released through the air outlet openings. Keep your hands and face at a safe distance from the steam and from the air outlet opening. Be careful of hot steam and air when you remove the pan from the appliance. Any accessible surface may become hot during use.
21. Immediately unplug the appliance if you see dark smoke coming out from the appliance. Wait for the smoke emission to stop before you remove the pan from the appliance.
22. Ensure that the appliance is placed on a horizontal, even, and stable surface.
23. This appliance is designed for household use only. It is not safe to use in environments, such as staff kitchens, farms, motels, and other non-residential environments.
24. The warranty is void if the appliance is used for professional or semiprofessional purposes, or it is not used according to instructions.
25. Always wait 30 minutes for the appliance to cool down before handling or cleaning it.

Electromagnetic Fields (EMF)

This GoWISE USA Air Fryer complies with all standards regarding Electro-magnetic fields(EMF). Under proper handling, there is no harm done to the human body based on available scientific evidence.

If you have any questions regarding your Air Fryer, please contact Customer Service at

855-233-9199.

Product Structure & Features

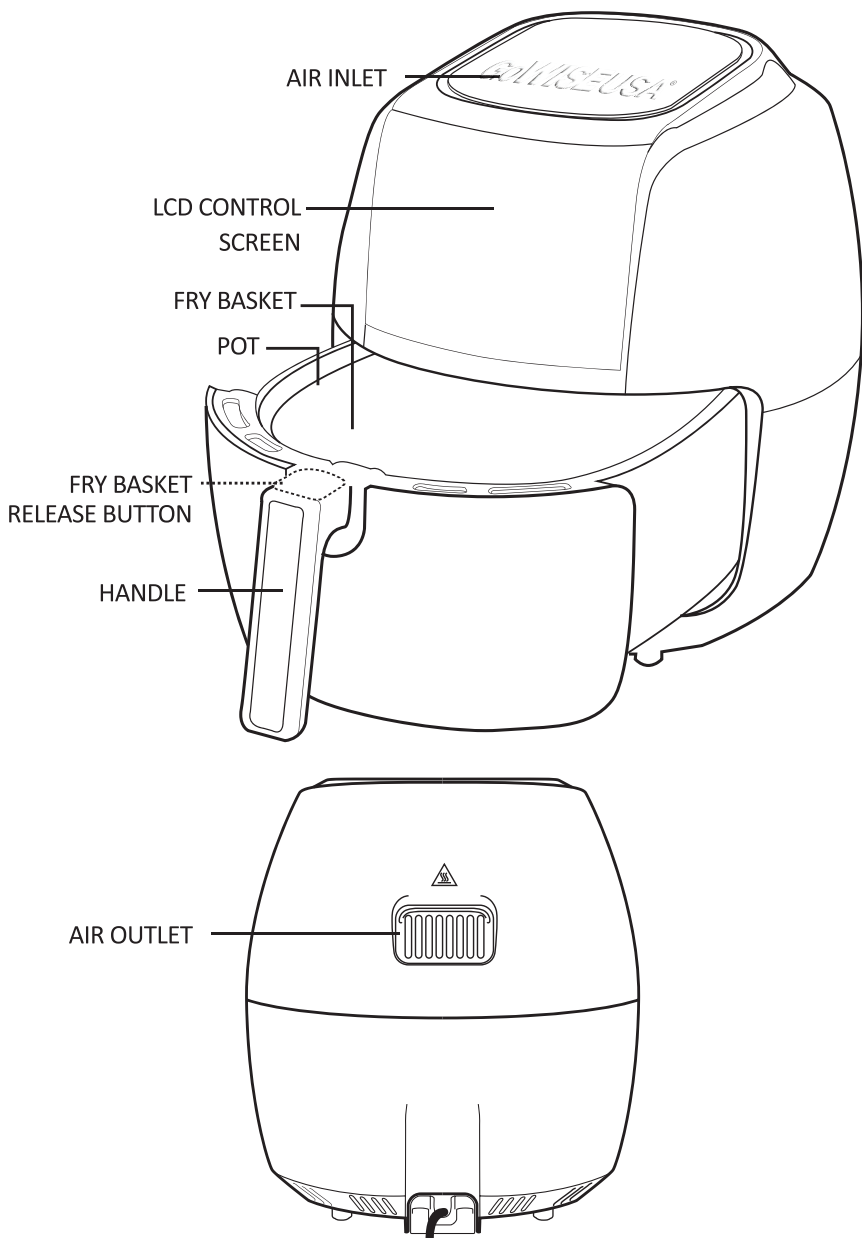

Product Structure & Features - continued

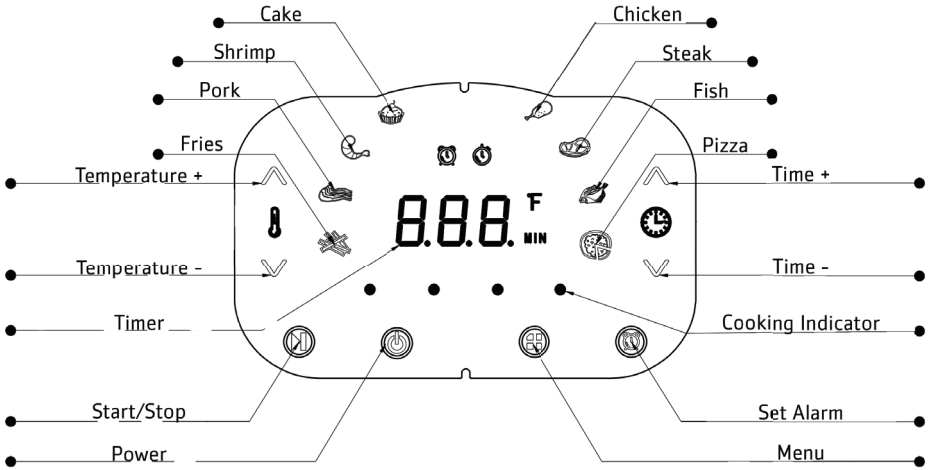





To cycle through the pre-set cooking programs, press the Power icon, then press the Menu icon. You can adjust time or temperature by pressing the “^” or “v” icons.

Before First Use

1. Remove all packaging materials, stickers, and labels.
2. Clean the basket and pan with hot water, soap, and a non-abrasive sponge.
3. Wipe the inside and outside of the appliance with a clean cloth.

NOTE: DO NOT fill pan with oil and frying fat because the appliance works on hot air.

How to Use Your Air Fryer

1. Place the air fryer on a flat and even surface. DO NOT PLACE THE AIR FRYER ON A SURFACE THAT IS NOT HEAT RESISTANT.
2. Place the basket in the pan. DO NOT FILL THE PAN WITH OIL OR ANY OTHER LIQUID.
3. Place the ingredients in the basket and then slide the basket and pan back into the appliance. The LCD should light up.
NOTE: The basket is equipped with a button guard that ensures safe detachment. Simply slide the button back to detach the basket from the pan.
4. Press the Power icon and set cooking time and temperature by either choosing one of the 8 preset cooking programs using the Menu icon or manually set time and temperature with " " or " " icons.
NOTE: To set up a different program after the fryer has started, press the "Start/Stop" button. Set a different program, then press the "Start/Stop" button again.
5. Press the Power icon once and set up the program by either choosing one of the pre-set cooking options using the Program button or manually setting a time and temperature using the " " and " " icons. Press the Power button again to start the fryer.

How to Use Your Air Fryer - continued

If you would like to make changes, such as adding more time or increasing the temperature, press the "START/STOP" icon to pause the cooking cycle and make your changes using the appropriate icons. Once you have made the adjustments, press the "START/STOP" icon to start the fryer again.

6. Once you have set the cooking time and temperature, press the "Start/Stop" button again. Four dots at the bottom of the display will blink repeatedly. If the four dots are solid, the cooker will go into standby mode.
7. There are some foods that you may need to shake midway through the cooking cycle to ensure even cooking. To do this, slide the pan out of the air fryer by the handle (the air fryer will automatically power down), then carefully shake the ingredients.
8. Slide the pan and basket back into the air fryer by carefully aligning the track inside the air fryer with the rim of the pan. If you are unable to insert the basket into the air fryer, try lifting the handle as you are sliding the basket into the fryer.

How to Use Your Air Fryer - continued

9. After sliding the pan back into the air fryer, it will automatically power back up. However, the timer will be reset to the original cook time. Please keep the time in mind before sliding back into fryer.

CAUTION: DO NOT SLIDE BACK THE BUTTON ON THE HANDLE DURING SHAKING, THIS WILL DETACH THE BASKET FROM THE PAN. If shaking the ingredients in the pan is difficult, first place pan on a pot holder, then release the basket, then shake the basket.

10. When the cooking time has been reached, the timer will beep five times. After the timer beeps, The air blower will stop shortly after (approx. 20 seconds).
11. Slide the pan out of the fryer and place it on a pot holder.
NOTE: Oil from the ingredients will gather in the bottom of the pan, be careful when sliding pan out of fryer.
12. To remove the ingredients, slide the button guard up and press the release button on the handle to free the basket from the pan. Carefully pour ingredients out of basket onto plate.

How to Use Your Air Fryer - continued

13. If you are using tongs, make sure to use non-abrasive, non-metal tongs to avoid scratching the non-stick coating on the basket.
14. Press the Power icon and the fan will run for at approx. 20 seconds, then will go into standby mode. NOTE: You must unplug the fryer to turn it off completely.

A Slide back handle cap to reveal the fryer basket release button

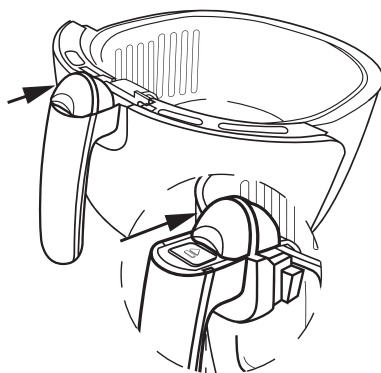

B Press fryer basket release button while pulling up handle to free the basket from the pot

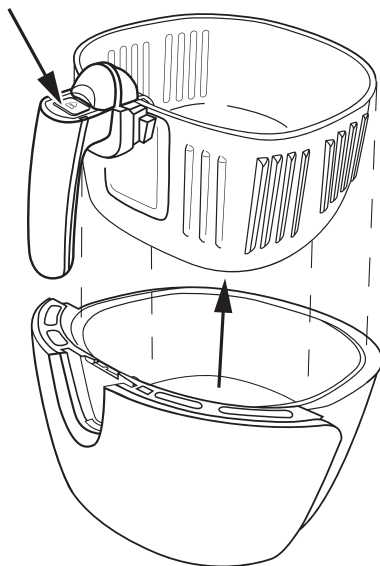

CAUTION: AFTER COOKING, NEVER PRESS THE RELEASE BUTTON DURING SHAKING; THIS WILL DETACH THE BASKET FROM THE PAN.

To order replacement parts please contact GoWISE USA® customer service at 855-233-9199.

How to Use Your Air Fryer - continued

Setting the Alarm Function

The alarm function alerts the user to check food in 5, 10, or 15 minutes into the set cooking time.

1. Press the "Start/Stop" button and choose either one of the cooking presets or manually set a time.
2. Press the "Alarm" button displayed with the alarm clock icon. This function will give you an option to set up in 5, 10, or 15 minutes.

3. Once you have chosen an alarm time, press the "Start/Stop" button to start the fryer. Both the cooking preset and alarm icons should be blinking during the cooking cycle.

NOTE: The alarm function will alert the user in the chosen interval depending on the set cooking time. For example, if the fryer is set to 30 minutes with an alarm function set up for 10 minutes, the fryer will beep every 10 minutes within the 30-minute cook cycle.

4. To turn off the alarm function, press the "Start/Stop" icon then press the "Alarm" button repeatedly until you see the set temperature.

Cooking Guide

The table below is a guide that will help you with setting the time and temperature for certain ingredients.

NOTE: Please keep in mind that because ingredients differ in size, shape, brand, and origin, we cannot guarantee that this is the best setting for the ingredients you have. However, Rapid Air Technology reheats the food inside the fryer instantly, therefore removing the pan of the air fryer for a brief period of time will not interrupt the cooking process.

TIPS:

- Small ingredients usually require shorter cooking time compared to larger ingredients.
- Shaking smaller ingredients midway through the cooking process will ensure the ingredients cook more evenly and give a better end result. Adding a very little amount of oil to fresh potatoes will give it a crispier result.
- Do not cook extremely oily ingredients, such as sausages in the air fryer.
- Snacks that can be prepared in a traditional oven can also be prepared in the air fryer.
- The recommended amount of fries to allow for a crispy result is 17.5 oz.
- Pre-made dough requires shorter cooking time than homemade dough. When making cake, quiche or ingredients with filling, use a baking tine or oven dish in the fryer basket.
- You can also use the air fryer to heat ingredients, set the temperature to 150° F for up to 10 minutes.

Cooking Guide - continued

Food	Time (minutes)	Temperature (°F)	Shake/Flip	Tips
Potatoes & Fries				
Thin Frozen Fries	9-16	400°F	Shake	Add 1/2 Tbsp of Oil
Thick Frozen Fries	11-20	400°F	Shake	
Homemade Fries	16-20	400°F	Shake	
Homemade Potato Wedges	18-22	360°F	Shake	
Homemade Potato Cubes	12-18	360°F	Shake	
Falafel	15	360°F	Shake	
Potato Gratin	15-18	400°F	Shake	
Meat & Poultry				
Steak	8-12	360°F	Flip	Line with tin foil
Pork Chops	10-14	360°F	Flip	
Hamburger	7-14	360°F	Flip	
Sausage Roll	13-15	400°F	Flip	
Drumsticks	18-22	360°F	Flip	
Chicken Breast	10-15	360°F	Flip	
Snacks				
Spring Rolls	8-10	400°F	Shake	
Frozen Chicken Nuggets	6-10	400°F	Shake	
Frozen Fish Sticks	6-10	400°F	Shake	
Frozen Mozzarella Sticks	8-10	360°F	Shake	
Stuffed Vegetables	10	320°F		
Baking				
Cake	20-25	320°F		Use baking tin
Quiche	20-22	360°F		
Muffins	15-18	400°F		
Sweet Snacks	20	320°F		

If you have any questions regarding your air fryer, please contact Customer Service at 855-233-9199.

Cleaning Your Air Fryer

1. Clean the fryer after every use. Unplug the fryer. ALWAYS WAIT UNTIL THE FRYER HAS COOLED TO A SAFE TEMPERATURE BEFORE HANDLING.
2. Wipe the outside of the fryer with a damp cloth.
3. Clean the pan and basket with hot water, soap and non-abrasive sponge. You can remove any stuck-on food by using a degreasing liquid soap. For any hard-to-remove food, soak the pan in hot water.
4. Clean the inside of the appliance with a lightly dampened non-abrasive sponge or cloth. Be careful not to get the inside of the appliance too wet and never submerge in water.
5. Clean the heating element with a cleaning brush to remove any food debris.

Troubleshooting

Problem	Possible Cause	Solution
The Fryer is not turning on	The appliance is not plugged in	Plug the appliance into a grounded wall socket
	You have not set the timer	Set the timer using the knob for the correct time on the appliance
Ingredients for the fryer are not done	The basket has been over filled with ingredients	Place smaller batches of ingredients in the basket. Smaller batches are fried more evenly
	The set temperature is too low	Increase the temp. control knob to the required temperature setting (see temperature presets in this manual).
The ingredients are fried unevenly in the fryer	Ingredient positioning or overflow	Ingredients that lay on top or across from each other(e.g. fries) need to be shaken midway through cooking
Fried snacks are not crispy after frying	Some snacks are crispier when traditionally fried	Use oven snacks or lightly brush some oil onto the snacks for a crispier result
Pan does not slide into fryer properly	Over filled basket	Do not fill the basket beyond the MAX fill indicator line
White smoke comes out from the fryer	It's normal for white smoke to appear when prepping greasy ingredients	When frying greasy ingredients a large amount of oil will leak into the pan. The oil produces white smoke and the pan may heat up more than usual. This does not affect the appliance or end food result
	The pan is still greasy	Clean pan properly after each use
Fresh fries are fried unevenly in the fryer	Potatoes are not fresh	Use fresh potatoes and make sure that they stay firm during frying
	Potato sticks have not been rinsed properly prior to frying	Make sure to rinse the potato sticks properly to remove the starch prior to frying
Fries are not crispy	Oil and water in fries	Potato sticks should be dry prior to adding oil
		Add more oil for a crispier result

Warranty

General Warranty excludes refurbished / auction items.

GoWISE USA has a 1-year limited warranty for all products. Products are warrantied against defects in materials and workmanship for 1 year from the date of purchase, when used in accordance with the instructions provided. This warranty does not cover damages or wear resulting from accident, misuse, abuse, commercial use, or unauthorized adjustment and/or repair.

For all GoWISE USA Air Fryers, the removable basket, tray and all components are warrantied for 30 days from the date of purchase and DO NOT fall under the 1-year limited warranty of the unit.

GoWISE USA shall not be liable for loss of use or any other incidental, consequential or indirect costs, expenses or damages. There are no express warranties except as listed above. This warranty gives you specific legal rights and you may have other rights which vary from state to state.

CALL 855-233-9199 for RETURN INSTRUCTIONS

WE DO NOT SERVICE PRODUCT OUTSIDE THE 48 CONTINENTAL UNITED STATES. WE WILL SHIP TO A FREIGHT FORWARDER FOR CUSTOMERS.

NOTE: Customers are responsible for all return shipping costs. When item(s) are returned under warranty as being defective, they are thoroughly tested to verify manufacturer defect. If any item(s) are determined to be in proper working order after testing, all shipping cost to have the product returned to the customer will be the responsibility of the customer.

Return Period: 30 Days

All return requests must be made within 30 days from the date our customers purchase their product(s). Refunds are only applicable during the 30-day return period and may be subject to restocking fees up to 15% of the original purchase amount. If the product

Warranty - continued

is defective within 30 days, GoWISE USA will cover the cost of return shipping. However, a photo and/or video from the customer is required to receive a pre-paid shipping label. If the product is missing any accessories that were included in the original packaging/shipment, or the product is damaged, altered or used, the item may no longer be eligible for a refund or replacement. Any decision of refund and/or replacement will be decided at the discretion of GoWISE USA.

NOTE: Customer are responsible for all return shipping costs after 30 days.

Defective/Freight Damaged:

Products that are within the 30-day return period and have been determined by customer service to be defective are qualified for a return label for the product to be returned to GoWISE USA for inspection and testing. GoWISE USA will provide a return shipping label for defective product(s) only. Customers must contact the carrier (shipping company) for products that have arrived damaged after initial transit. Clear photographic and video proof of damage and/or defective product(s) is REQUIRED prior to GoWISE USA authorizing the return of any product.

Purchase from 3rd Parties:

In order for the GoWISE USA customer service team to lookup the warranty information regarding the product(s), the original order information and/or proof of purchase is required. Without this information, GoWISE USA will be unable to move forward with providing a replacement under warranty, as we do not know the date or origin of the purchase. GoWISE USA does not have a working business relationship with 3rd party selling sites or services or individuals which are not listed below as one of our authorized retailers. GoWISE USA is not responsible for making inquiries to such 3rd parties for the purpose of obtaining documentation. It is the responsibility of the person(s) making the warranty claim to provide original documentation such as

Warranty - continued

order information and/or a receipt so that customer service can process the request. Any claim made under GoWISE USA warranty guidelines must be made by original purchaser of the product(s). Any defective product(s) will be replaced as long as the issues with the device fall within warranty guidelines.

Authorized Retailers:

GoWISE USA (Amazon and Sears Marketplace)

Wayfair

Houzz

Home Depot

MorningSave.com

Bed Bath Beyond

Notes

GoWISE USA®

www.gowiseusa.com
support@gowiseusa.com
1-855-233-9199

- To ensure correct use of this appliance, read these instructions carefully and thoroughly.
- Please keep this manual for future reference.
- Thank you for purchasing this GoWISE USA electric air fryer.

USE PROMO CODE: **LIVewisERAF**

10% OFF

YOUR NEXT **GoWISE USA®** PURCHASE

