

Package Contents

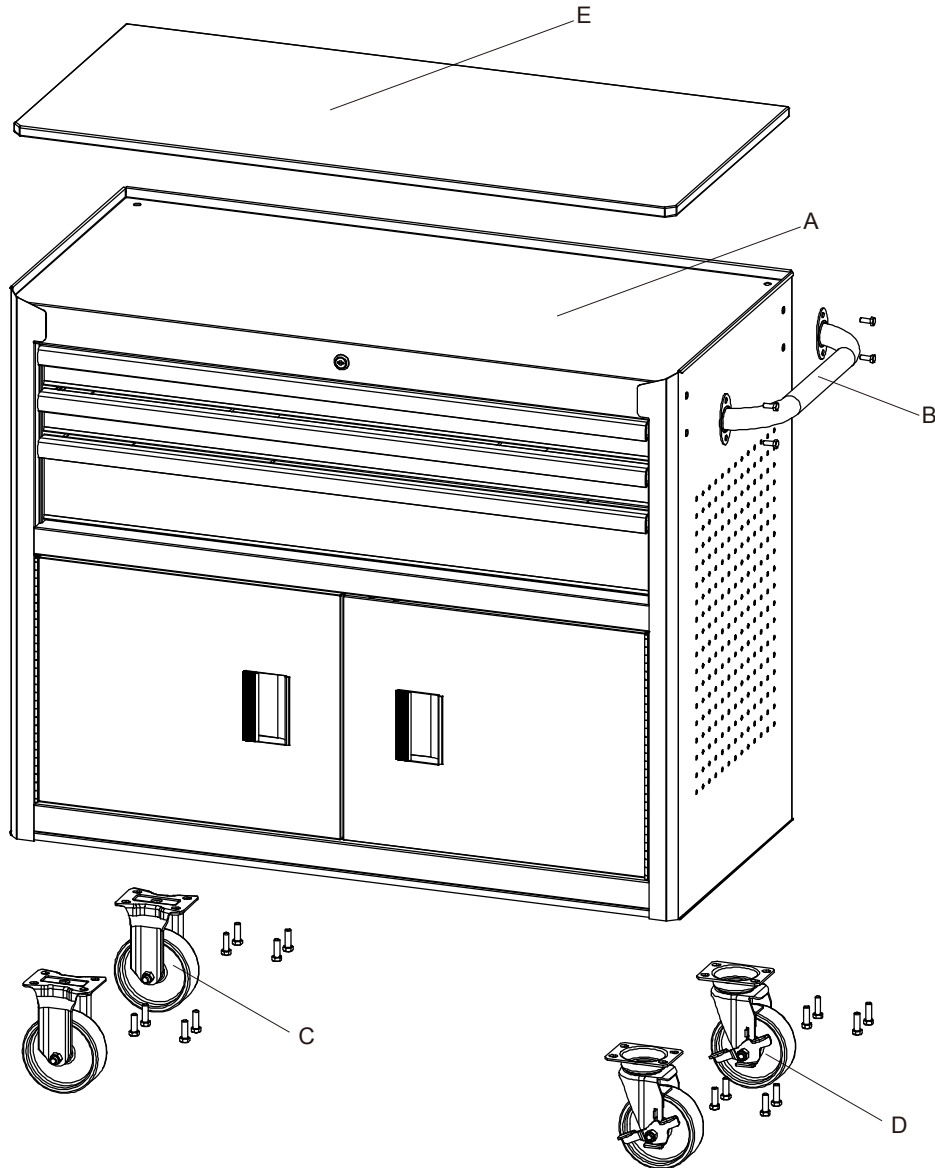

NOTE: The keys are taped to the top of the unit.



Part	Description	Quantity
A	Cabinet	1
B	Cabinet handle	1
C	Fixed caster	2
D	Swivel caster	2
E	Wood top	1

Package Contents

HARDWARE INCLUDED



NOTE: Hardware not shown to actual size.



Part	Description	Quantity
AA	M8 x 25 bolt	16
BB	M6 x 16 bolt	4
CC	Wrench	1

ALTERNATIVE TOOLS FOR ASSEMBLY (Not Included)



*10 mm wrench or socket

*12 mm wrench or socket

Assembly

1 Attaching the cabinet handle

- Position the cabinet handle (B) over the holes on the cabinet (A).
- Attach with the bolts (BB) and tighten with supplied wrench (CC) or 10mm wrench/socket.



NOTE: The holes in the cabinet are tapped and do not require nuts.

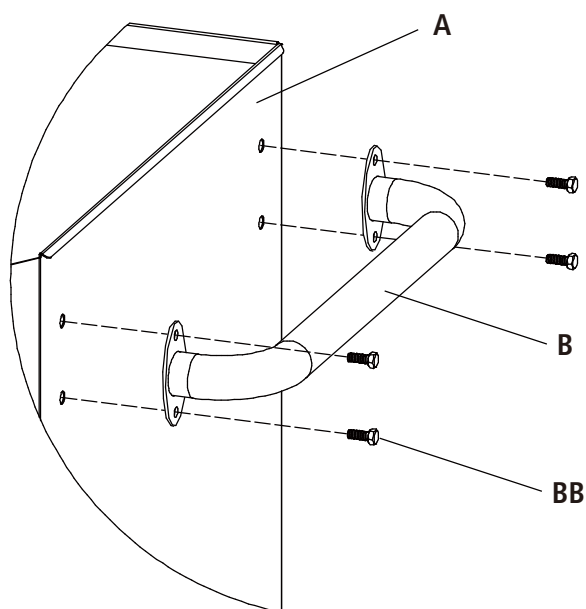

2 Attaching the casters

- Remove wood top (E) and set aside.
- Be sure the drawers are locked and lay the cabinet (A) on its top. Use packaging material to protect the finish.
- Attach the swivel casters (D) to the unit, on the same side as the handle, inserting bolts (AA) through the swivel casters (D) and into the cabinet (A).
- Tighten with supplied wrench (CC) or 12 mm wrench/socket.
- Repeat this process for the fixed casters (C) on the opposite side of the cabinet (A).
- Return the cabinet (A) to its upright position.
- Replace wood top (E).



CAUTION: Do not over tighten the bolts.

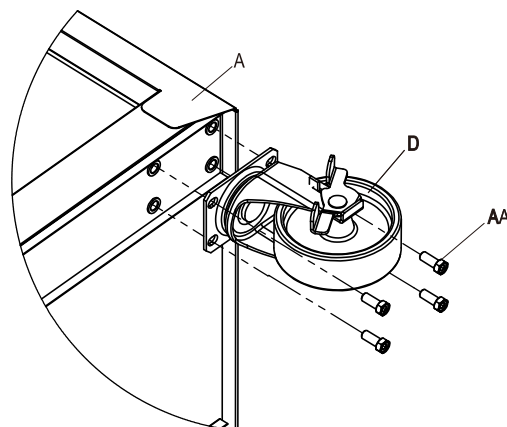

Operation

1 Removing the drawers

- Fully extend the empty drawer.
- Push up the one release lever while pulling down on the other release lever.
- Pull the drawer outward until it is released from the drawer slide.

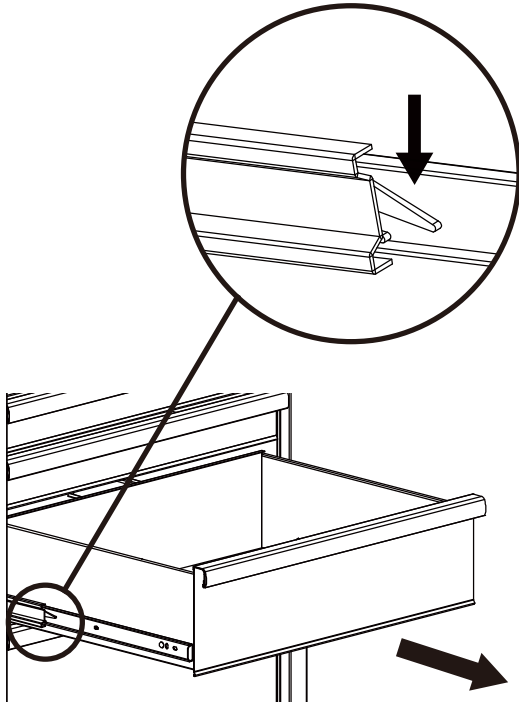

2 Re-inserting the drawers

- Extend the drawer slides.
- Insert the brackets on each side of the drawer into the slots in the slides, being careful that they are properly positioned.
- Once properly inserted, completely close the drawer to set the slides in their proper positions.

