



**READ AND UNDERSTAND ALL INSTRUCTION, WARNING, AND DANGER LABELS.
PARA INSTRUCCIONES EN ESPAÑOL, REFIÉRASE AL MANUAL DEL OPERADOR.**



1

A. Loosen the top two lock nuts securing the upper and lower handle and remove the two carriage screws from the lower handle and set aside.

B. Place shift lever into F6 position.

C. Pivot upper handle into operating position.

D. Attach the two carriage screws and lock nuts removed in Step 1. Finish securing the handle by tightening the top two lock nuts loosened in Step 1.

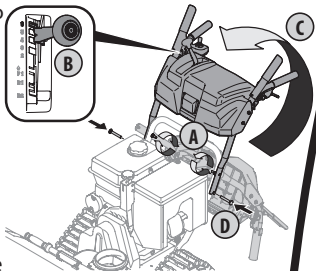

FAST START GUIDE

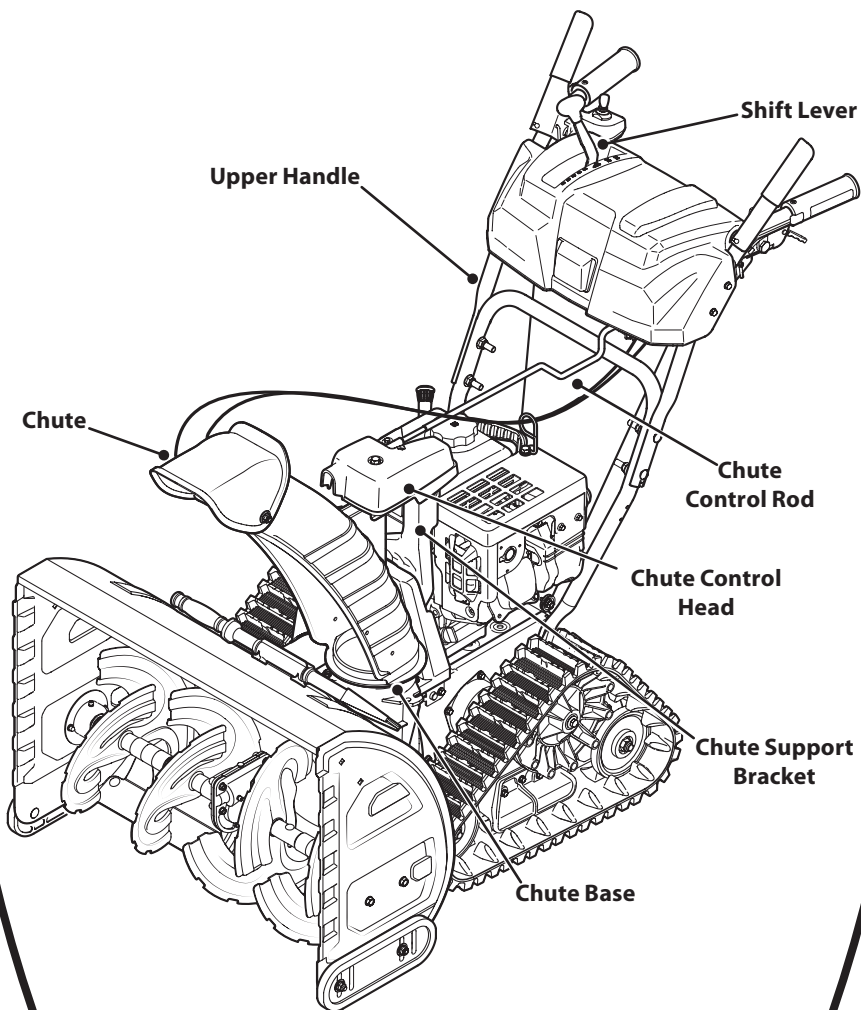

2

A. Remove cotter pin, wing nut and hex screw from chute control head.

B. Remove clevis pin and bow-tie pin from chute support bracket.

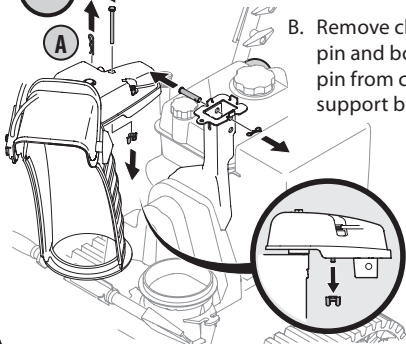

3

Insert the round end of the chute control rod (hole pointing upward) as far as possible into the chute control head.

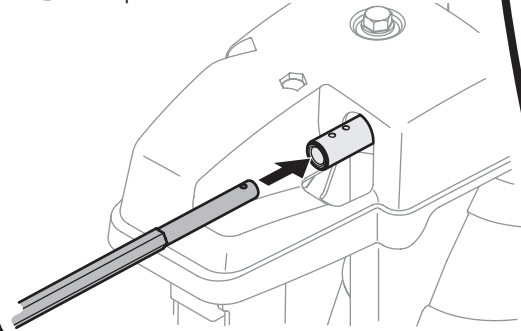

4

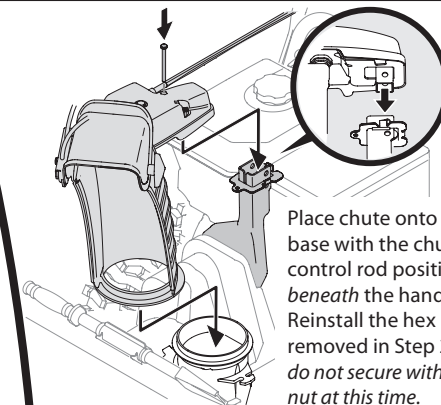

Place chute onto chute base with the chute control rod positioned *beneath* the handle panel. Reinstall the hex bolt removed in Step 2 but *do not secure with wing nut at this time.*

5

Insert the opposite end of the chute control rod into the coupler below the handle panel.

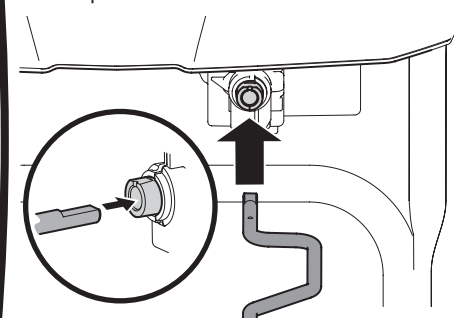

6

Insert the cotter pin removed in Step 2 into the center hole to secure the round end of the rod to the chute control head.

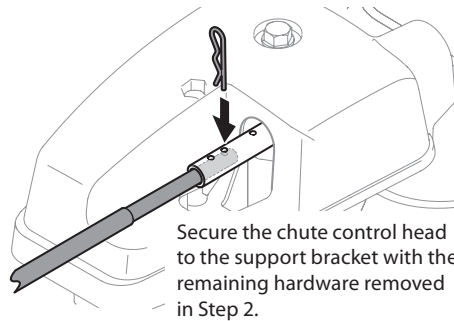

Secure the chute control head to the support bracket with the remaining hardware removed in Step 2.



IMPORTANT: READ OPERATOR'S MANUAL AND ENGINE MANUAL THOROUGHLY AND FOLLOW THE IMPORTANT SAFE OPERATION PRACTICES BEFORE OPERATING.



Need Help? Call 1-888-TO-HELP-U



READ AND UNDERSTAND ALL INSTRUCTION, WARNING, AND DANGER LABELS.
 PARA INSTRUCCIONES EN ESPAÑOL, REFIÉRASE AL MANUAL DEL OPERADOR.



7



Check the oil level using the dipstick. Add oil if necessary. (Refer to the Operator's Manual)



Fill fuel tank with clean, fresh gasoline. Do not fill above the base of fuel tank neck.

8

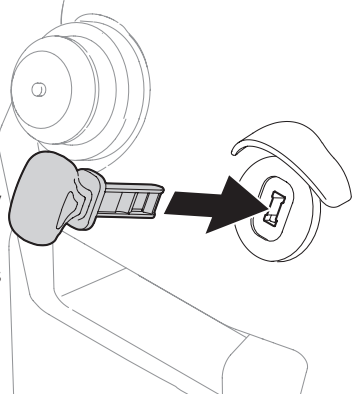

Insert the key into the key switch until the key snaps into place. Do *not* turn the key!

9

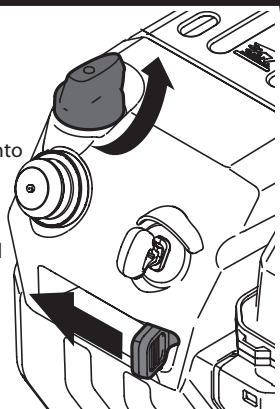

Move throttle control into the Fast position.

Move the choke control into the Choke position.

FAST START GUIDE

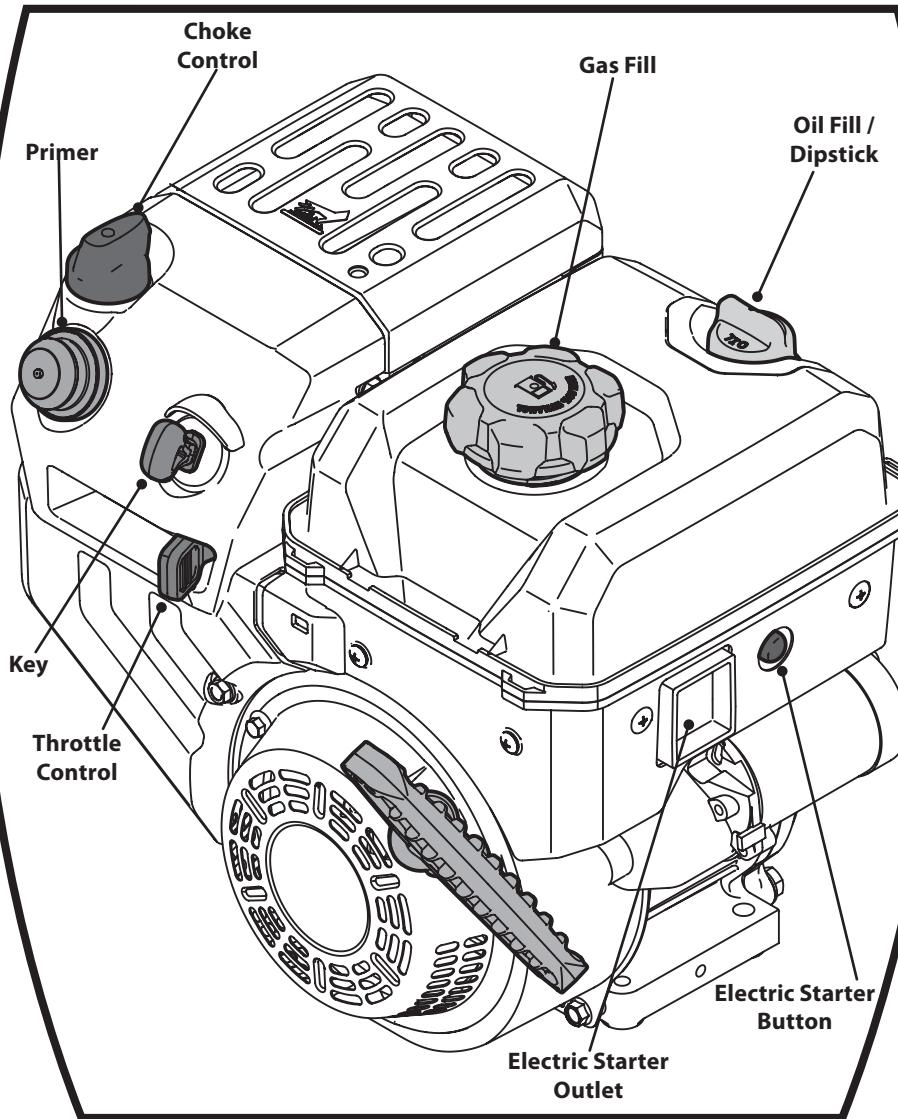

- Connect an extension cord to the electric starter outlet.
- Plug the other end of the cord into a three-prong 120-volt, grounded, AC receptacle.

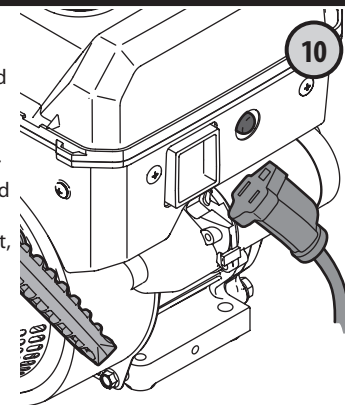

Push primer three times.

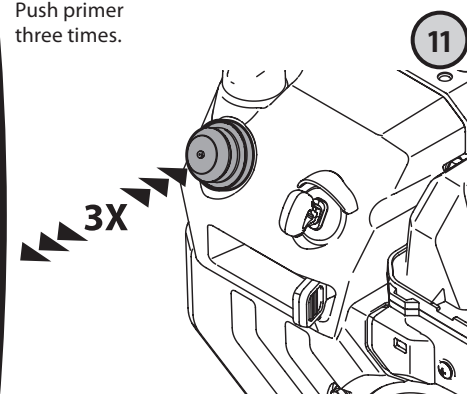

- To start engine, push the starter button.
- When engine starts, slowly move choke control into the Run position.
- Disconnect cord from power receptacle *first* and then from snow thrower's outlet.

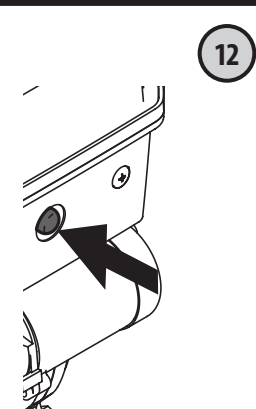

IMPORTANT: READ OPERATOR'S MANUAL AND ENGINE MANUAL THOROUGHLY AND FOLLOW THE IMPORTANT SAFE OPERATION PRACTICES BEFORE OPERATING.



Need Help? Call 1-888-TO-HELP-U