

210\*290mm



SKU# 305 543 508  
SKU# 1003 382 575  
Model #PN324A50A1-40

## USE AND CARE GUIDE

### LED FLAT PANEL FIXTURE



Questions, problems, missing parts? Before returning to the store, call Commercial Electric Customer Service  
8 a.m. - 7 p.m., EST, Monday - Friday, 9 a.m. - 6 p.m., EST, Saturday

1-877-527-0313

HOMEDEPOT.COM

#### THANK YOU

We appreciate the trust and confidence you have placed in Commercial Electric through the purchase of this LED Flat Panel Fixture. We strive to continually create quality products designed to enhance your home. Visit us online to see our full line of products available for your home improvement needs. Thank you for choosing Commercial Electric!

## Table of Contents

Table of Contents	2
Safety Information	2
Warranty	2
Pre-Installation	3
Tools Required	3
Hardware Included	3
Specification	3
Installation	4

## Safety Information

### For your safety, always remember to:

- Turn off the power supply at the fuse or circuit breaker box before you install the fixture.
- Ground the fixture to avoid potential electric shocks and to ensure reliable starting.
- Double-check all connections to be sure they are tight and correct.
- Wear rubber soled shoes and work on a sturdy wooden ladder.
- Account for small parts and destroy packing material, as these may be hazardous to children.

This fixture is designed for use in a circuit protected by a fuse or circuit breaker. It is also designed to be installed in accordance with local electrical codes. If you are unsure about your wiring, consult a qualified electrician or local electrical inspector, and check your local electrical code.

**WARNING: RISK OF SHOCK.** House electric current can cause painful shock or serious injury unless handled properly.

**CAUTION:** Turn off the main power at the circuit breaker before installing the fixture, in order to prevent possible shock.

**NOTICE:** All electrical connections must be in accordance with local and National Electrical Code (N.E.C.) standards. If you are unfamiliar with proper electrical wiring connections obtain the services of a qualified electrician.

Remove the fixture and the mounting package from the box and make sure that no parts are missing by referencing the illustrations on the installation instructions.

## FCC STATEMENT

-This device complies with part 15 of the FCC Rules. Operation is subject to the following two conditions:  
(1) This device may not cause harmful interference, and (2) this device must accept any interference received, including interference that may cause undesired operation.  
Note: This equipment has been tested and found to comply with the limits for a Class B digital device, pursuant to part 15 of the FCC Rules. These limits are designed to provide reasonable protection against harmful interference in a residential installation. This equipment generates, uses and can radiate radio frequency energy and, if not installed and used in accordance with the instructions, may cause harmful interference to radio communications. However, there is no guarantee that interference will not occur in a particular installation. If this equipment does cause harmful interference to radio or television reception, which can be determined by turning the equipment off and on, the user is encouraged to try to correct the interference by one or more of the following measures: Reorient or relocate the receiving antenna. Increase the separation between the equipment and receiver. Connect the equipment into an outlet on a circuit different from that to which the receiver is connected. Consult the dealer or an experienced radio/TV technician for help. Any changes or modifications not expressly approved by the manufacturer could void the user's authority to operate the equipment.

## Warranty

### LIMITED WARRANTY

This product is warranted to be free from defects in workmanship and materials for up to 5 years from date of purchase. If it fails to do so, please contact the Customer Service Team at 1-877-527-0313 or visit [www.HomeDepot.com](http://www.HomeDepot.com).

2

## Pre-Installation

### TOOLS REQUIRED



### HARDWARE INCLUDED

NOTE: Hardware not shown to actual size.

Part	Description	Quantity
EE	Wire Nuts	3

## Specification

Model No.	Volts (V)	Frequency (HZ)	Watts (W)	Current (mA)
PN324A50A1-40	120V-277V	50/60	50	420

## Recessed Installation

- 1** Remove the LED flat panel fixture from the package. Ensure that the power is turned off before installing the fixture.
- 2** Fold the 4 pieces of T-Gird clips as picture shows.

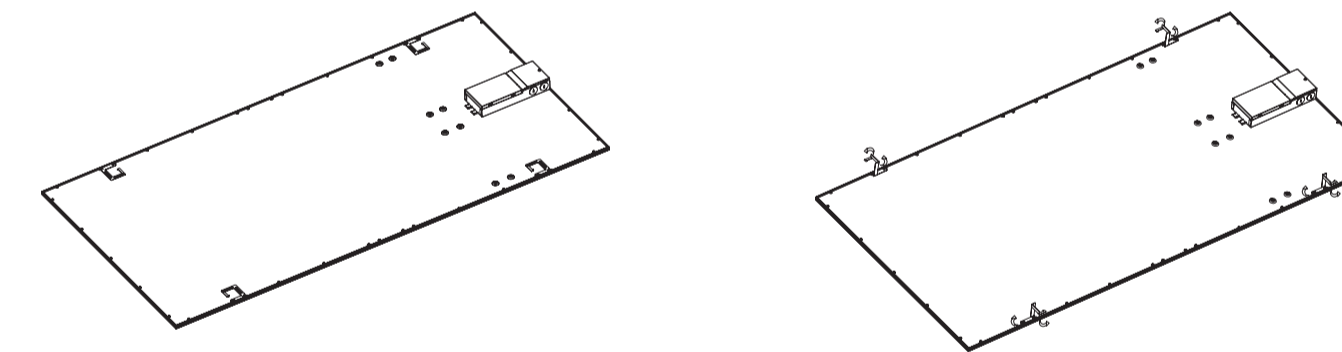

3

HOMEDEPOT.COM

Please contact 1-877-527-0313 for further assistance.

## Recessed Installation

- 3** Place the LED flat panel fixture into ceiling and ensure the power supply is off.
- 6** Connect the electrical wires from the power supply to the LED Flat panel fixture power supply, and 0-10V dimmer.

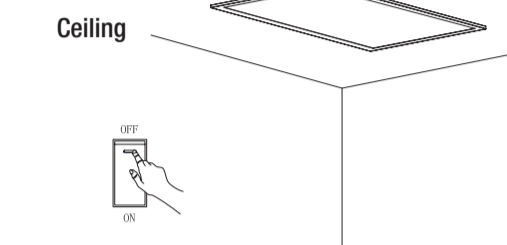

- 4** Fix the flat panel fixture on the T bar grid in the ceiling by twisting 4 pcs of T bar grid clips onto the bar.

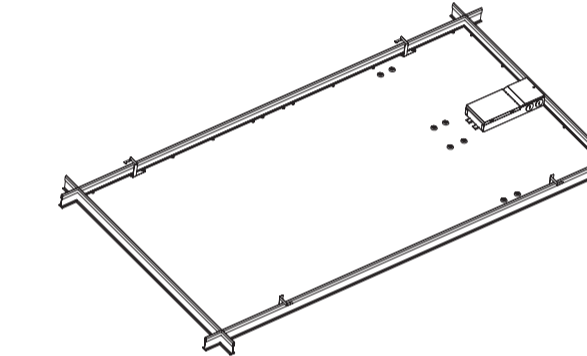

- 5** Remove the cover of junction box on the back of the fixture with a screwdriver. Remove the knockouts on the A and B side with a screwdriver.

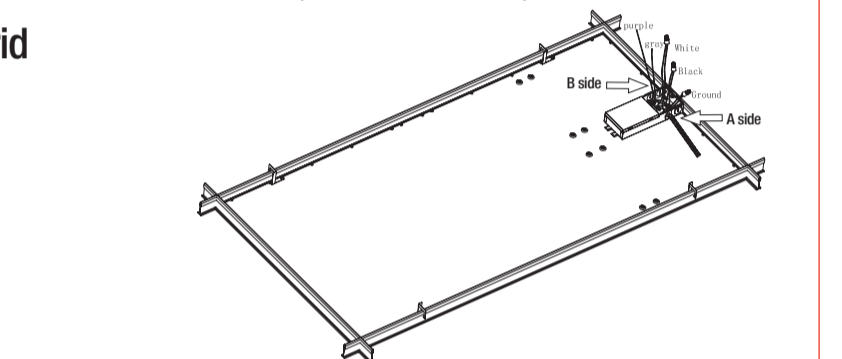
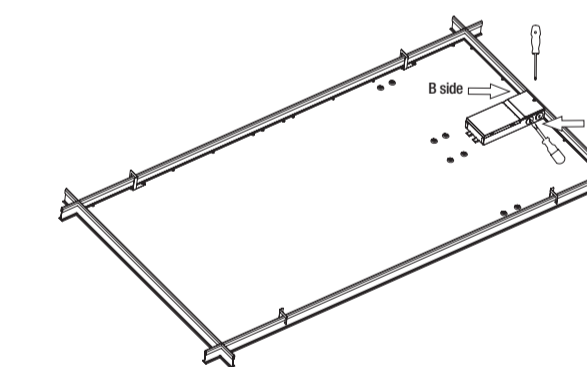

- 7** Attach the junction box cover plate on the LED Flat Panel fixture with the screw using a screw driver. Turn on the power supply.

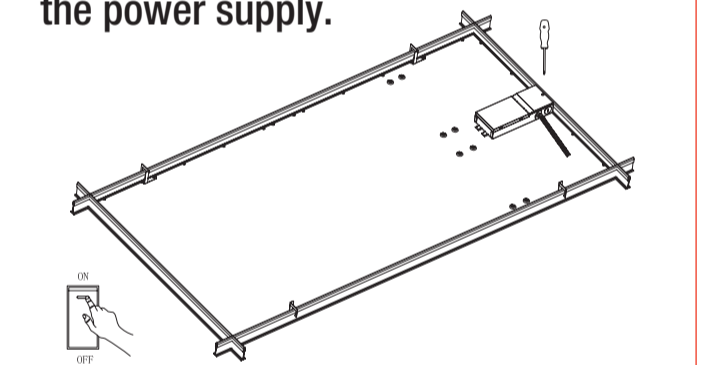

Questions, problems, missing parts? Before returning to the store, call Commercial Electric Customer Service  
8 a.m. - 7 p.m., EST, Monday - Friday, 9 a.m. - 6 p.m., EST, Saturday

1-877-527-0313

HOMEDEPOT.COM

Retain this manual for future use.

4