

Superstrut®

Superstrut® Metal Framing System

In this section...

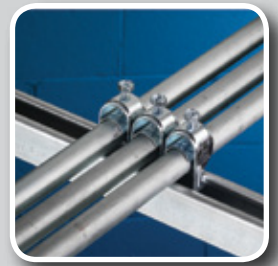

Superstrut® Metal Framing System

| | |
|---|-------------|
| Overview | B-106-B-109 |
| Channels | B-110-B-111 |
| Threaded Products and Hardware | B-112-B-117 |
| Fittings and Brackets | B-118-B-125 |
| Concrete Inserts | B-126-B-127 |
| Beam Clamps | B-128-B-135 |
| Pipe Straps, Conduit Clamps and Hangers | B-136-B-182 |
| Surface Raceway and Lighting Systems | B-183-B-187 |
| Slotted Angle Metal Framing | B-188-B-189 |
| Special Metals and Finishes | B-190-B-198 |
| Technical Information | B-199-B-220 |

Thomas&Betts

www.tnb.com

Overview



New Trivalent GoldGalv® Finish Is RoHS Compliant

Thomas & Betts is proud to introduce the new and improved Trivalent GoldGalv® finish. GoldGalv® finish is a combination of .5 mils electro-plated zinc and a gold Trivalent Chromium finish.

- **Gold Trivalent Chromium Finish** — The new GoldGalv® finish features a Trivalent Chromium formulation that provides all the features and protection of Hexavalent Chromium (CR VI) without the use of this chemical compound. Hexavalent Chromium is restricted by some standards such as the European Union directive on the restriction of the use of certain hazardous substances in electrical and electronic equipment (RoHS).
- **RoHS Compliant** — One great feature for the new Trivalent Chromium formulation is RoHS compliance. Because Hexavalent Chromium is a substance that is restricted by RoHS, moving away from a Hexavalent formulation to the new Trivalent formulation will make the performance of GoldGalv® coating available to customers affected by RoHS and other standards like RoHS around the world.
- **Trivalent GoldGalv® Finish Is OSHA Safe** — The Hexavalent formulation of the GoldGalv® finish is safe with regard to the revised 2006 OSHA standard. This new Trivalent formulation of the GoldGalv® finish does not contain any Hexavalent Chromium and therefore does not fall under the scope of the OSHA standard at all. As a result, the new Trivalent GoldGalv® finish, just like the Hexavalent GoldGalv® finish, is OSHA compliant.
- **ASTM B633 Specification** — The improved GoldGalv® finish is applied in compliance with ASTM B633 coating, the same standard as used previously. This standard outlines electro-deposited coatings of zinc on steel.



Overview

Finishes

GoldGalv®

The standard GoldGalv® finish is made up of a multi-step zinc electrogalvanizing process. The Trivalent Chromium finish is applied over the zinc, producing a chemically bonded non-porous barrier for protection from moisture and air. The .5 mil electro-plated zinc and gold Trivalent Chromium finish provides all of the features and protection of Hexavalent Chromium without the use of the chemical.

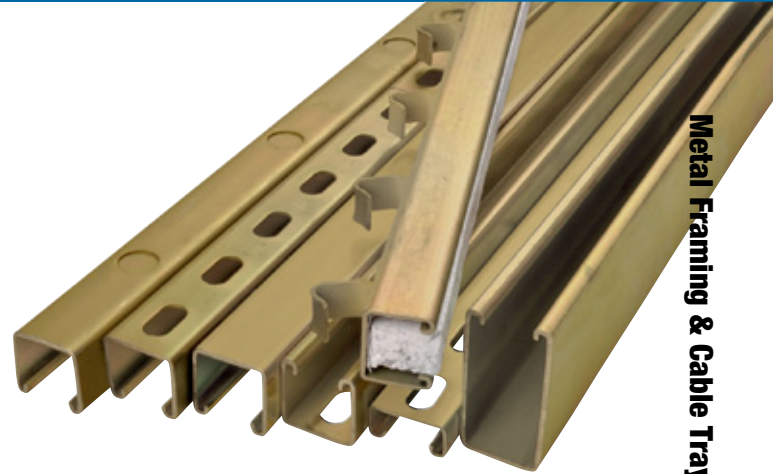

Metal Framing & Cable Tray — Superstrut® Metal Framing System

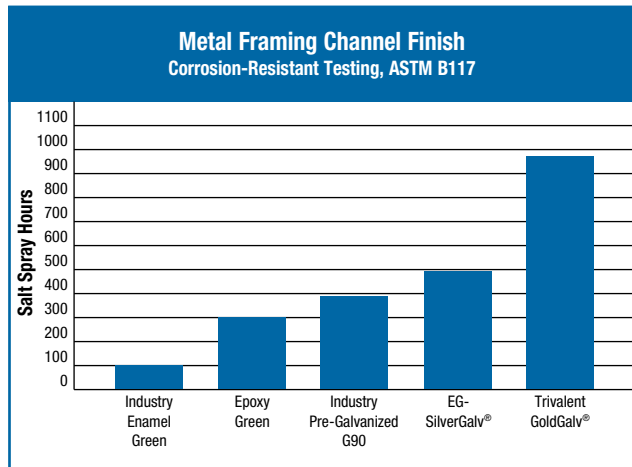
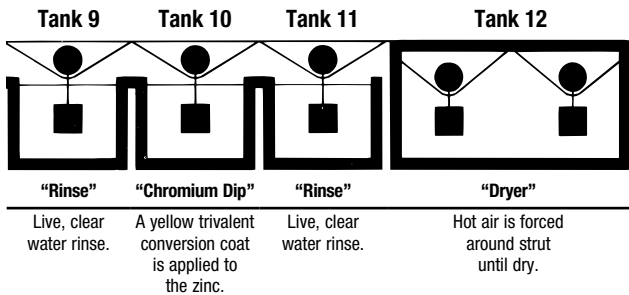
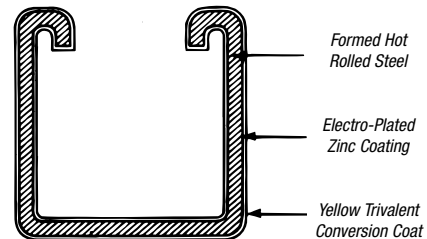
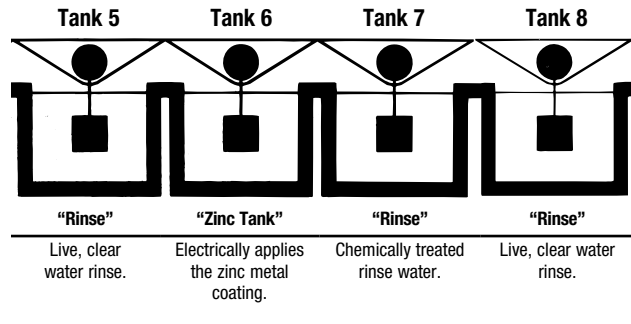
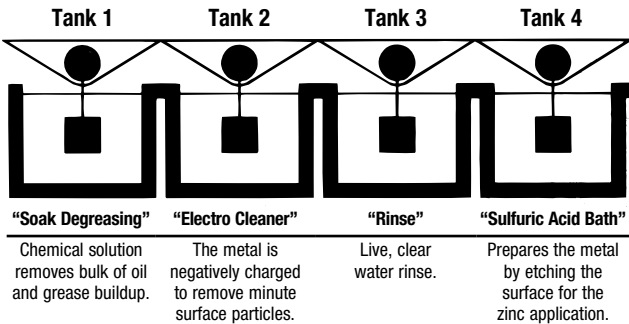

Overview

Outperforms the Competition

Superstrut® SilverGalv®

The Superstrut® SilverGalv® finish is a post-fabrication, 12-step electrogalvanizing process that applies a clear conversion coat over .5 mils of zinc. This process provides a strong, cohesive molecular bond that locks out moisture and superior corrosion resistance over standard G90 pre-galvanized channel.

- **No More White Rust** — With pre-galvanized struts, a common quality issue is the formation of white rust on the zinc finish. With SilverGalv®, a clear conversion coat is applied over the zinc to seal it and stop the formation of white rust.
- **Strong Abrasion Resistance** — The SilverGalv® finish won't chip or peel like a green painted strut product. It stands up to rough handling.
- **Superior Corrosion Protection** — One hallmark of the SilverGalv® finish is the superior corrosion protection it provides. In the ASTM B117 salt spray test, the new SilverGalv® finish provided improved protection as compared to painted finishes or G90 Pre-Galvanized. This outstanding corrosion protection means more versatile installations and more service life for SilverGalv® finished products.
- **Punched Holes and Cut Ends Are Protected** — Unlike a pre-galvanized finish where bare steel holes and cuts have no corrosion protection, SilverGalv® protects every portion of the strut. Because the SilverGalv® finish is applied after fabrication, all punched holes and cut ends share a consistent quality with the rest of the material — even after cutting or fabricating. SilverGalv® will continue to protect with its sacrificial zinc process.
- **Paintable Surface** — The new SilverGalv® finish provides a non-porous and non-crystalline surface. Not only does this feature provide enhanced corrosion protection, but also provides an excellent bond for the paint of your choice.
- **Clean Finish** — SilverGalv® ensures a finished product that leaves no residue on your hands. In the SilverGalv® process, a zinc finish is applied after fabrication. As a result, all of the oil and grime that accumulates during manufacturing gets thoroughly cleaned off during the plating process.
- **Great Electrical Conductivity** — Unlike paint or enamel, the SilverGalv® surface offers a minimum of electrical resistance, so electrical applications are easily grounded when grounding is needed.



Complete Offering of SilverGalv® Fittings and Accessories

Mismatched strut assemblies are a thing of the past with Superstrut SilverGalv. With a complete line of channel, hardware, fittings, hangers and pipe straps, all components have the same electrogalvanized finish for consistent performance and uniform aesthetics.

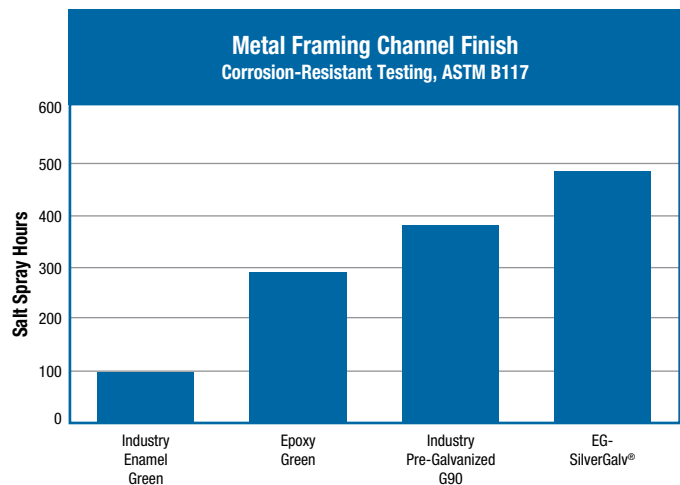

Overview

Finishes (continued)

GoldGalv®

The standard GoldGalv® finish is made up of a multi-step electrogalvanizing and zinc trivalent chromium process. The trivalent chromium finish is applied over the zinc, producing a chemically bonded non-porous barrier for protection from moisture and air. The .5 mil electro-plated zinc and gold trivalent chromium finish provides all of the features and protection of hexavalent chromium without the use of the chemical.

SilverGalv® (Suffix EG)

Often referred to as “zinc plated” or “electroplated zinc,” the steel and .5 mils of zinc are bonded by an electrolysis process. This is the identical process used in the Superstrut Goldgalv® finish without the numerous benefits of the gold-colored trivalent chromium conversion coat (see GoldGalv® finish for more information). Electrogalvanizing is most commonly applied to small fittings, hardware and threaded products.

Green or White Urethane Powder Coated (Suffix GR or WH)

Urethane powder resins are applied electrostatically to the steel after fabrication. Once the material is completely covered with the powder-form urethane, it proceeds through a 400° baking process for ten minutes, creating a chemical bond. This results in a minimum of 1.5 mil thickness of urethane coating, providing excellent resistance to chipping or peeling.

Pregalvanized (Suffix PG)

A zinc coating is applied by hot-dipping the steel coil at the mill prior to fabrication. Once the material is worked by roll-forming, cutting or punching, minimal protection is provided for raw edges. This weakness is typical with pre-coated material and affects the channel section around holes, extreme ends and the edges of the “U” shape lips. Superstrut pregalvanized material is in conformance with ASTM A-525/G-90 specification standards, representing 0.90 ounces of zinc per square foot of steel. This finish is often referred to as “hot-dipped mill galvanized” or “mill galvanized.”

Hot-Dipped Galvanized (Suffix HDG)

The material is zinc coated after fabrication, providing total product protection on all surfaces. The fabricated channel or fitting is suspended and then dipped into tanks of hot zinc for a prolonged period, creating a coherent bond. The result is superior corrosion resistance as compared to pregalvanized material. Hot-dipped galvanizing is not recommended for threaded products, because the thickness of the zinc coating will often disrupt the threads. Superstrut hot-dipped galvanized is in conformance with ASTM Specifications A-123 (formerly A-386) and A-153. Superstrut channels maintain a minimum 1.5 ounces of zinc per square foot of steel or 2.5 mils (ASTM A-123, Thickness Grade 65). This finish is also referred to as “hot-dipped galvanized after fabrication.”

PVC Coated (Suffix PVC)

A polyvinyl chloride (PVC) plastic coating is fused to the channel, fitting or accessory after fabrication by immersing the part in fluidized PVC tanks. The fused-melt mixed powder PVC coating thickness is 15 mils (.015”) plus or minus five mils. PVC material is a thermoplastic and will soften in high temperature. An inherent weakness with PVC coatings occurs when field alterations are applied, such as cutting or drilling. These acts disrupt the sealed PVC product and warrant field touch-up. Thomas & Betts cannot be held responsible for field-altered PVC coated products.

Copper Plated (“T” inserted as the second digit of the part number; Example: CTL-710-2)

Plain steel proceeds through a series of rinse tanks to clean the material surface. Once cleaned, the fabricated part is etched by dipping into an acid pickle bath to prepare the surface for adhesion. Copper is electrically applied by submerging in a copper bath. To seal the finish, the product continues to a sealer tank and is then dried by forced hot air.

Black (Suffix B)

A black finish is raw steel with only a light oil finish as supplied by the steel manufacturer. There is no protection against red rust.

Stainless Steel (Suffix SS)

Superstrut channel is supplied in type 304 stainless steel when required. Type 316 stainless steel may be available upon request.

Aluminum (Suffix AL)

Superstrut channel and hardware are available in aluminum.

Warning: Load tables, charts and design criteria provided in this catalog are intended as guides only. Selection of proper product, installation intervals, erection and placement are the responsibility of the user.

Superstrut® products are intended to be used for the support and bracing of fixtures, cable, pipe and conduit. Improper use or installation may result in injury to persons or damage of property.

Material and finish specifications are subject to change without notice.



Channels

Standard Channels

Material

Channels are cold formed from hot-rolled pickled and oiled strip steel.

Material Thickness

All Series 1200 12 gauge material
All Series 1400 14 gauge material

Standard Lengths

Standard lengths for channel are 10 ft. and 20 ft.

Standard length tolerance $\pm \frac{1}{8}$ ".

Shorter lengths are available at a small cutting charge.

GoldGalv® hardware finish is standard for all Superstrut products. This is a multi-process finish of electro-plated zinc, followed by gold colored trivalent chromium to give excellent corrosion resistance and superior paint base. See **pages B-106–B-107** for a complete description of the GoldGalv® hardware finish. GoldGalv® hardware will be furnished if no other finish is specified.

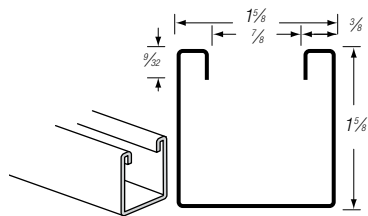

A-1200
Channel available in Solid, Half Slot, Punched, Slotted and Knockout configurations.
Wt./Ft. 1.90 lbs.

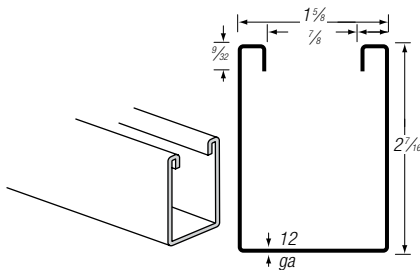

E-1200
Channel available in Solid, Half Slot and Punched configurations.
Wt./Ft. 2.47 lbs.

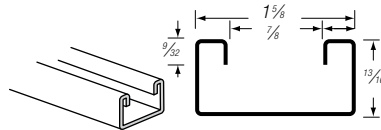

B-1200
Channel available in Solid, Half Slot, Punched and Slotted configurations.
Wt./Ft. 1.28 lbs.

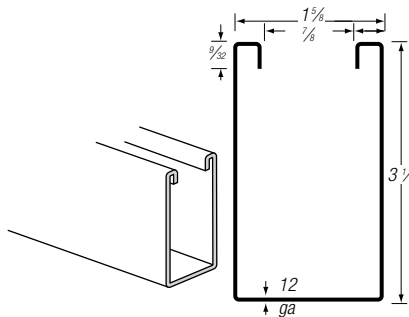

H-1200
Channel available in Solid, Half Slot and Punched configurations.
Wt./Ft. 3.05 lbs.

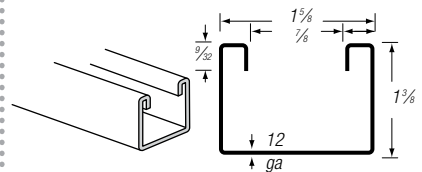

C-1200
Channel available in Solid, Half Slot and Punched configurations.
Wt./Ft. 1.70 lbs.

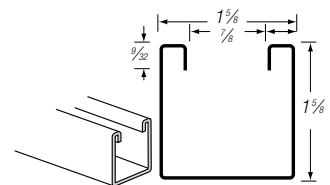

A-1400
Channel available in Solid, Half Slot, Punched, Slotted and Knockout configurations.
Wt./Ft. 1.40 lbs.

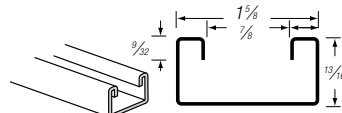

B-1400
Channel available in Solid, Half Slot, Punched and Slotted configurations.
Wt./Ft. 0.90 lbs.

Channels

Superstrut® Channels — Welding Combinations

All Superstrut® Channels are available in a variety of combinations — some are shown here.

Multiple channels are spot welded on 3" centers.

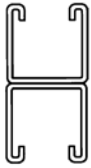

2*

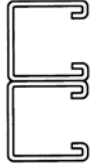

2-A

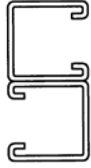

2-B

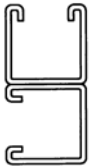

2-C

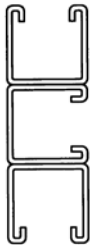

3-A

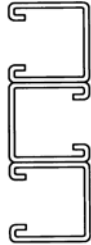

3-B

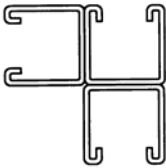

3-C

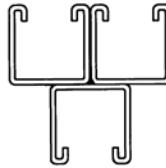

3-D

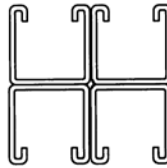

4

How to Order

10 and 20 ft. lengths — steel. Special lengths may be ordered.

Replace the 3 last digits of the regular channel catalog number with the designation of the desired combination.

Examples:

Two A-1200 channels back to back are ordered as A-1202.

Two A-1200 channels back to side are ordered as A-1202-C.

Specify desired finish or material.

**"A" and "B" Series back-to-back combinations are joined using Thomas & Betts' steel rivet joining process. The riveted channel is offered in standard GoldGalv®, stainless steel, painted, pre-galvanized and hot-dip galvanized finishes.

Hole Configurations

Half-Slot Channel

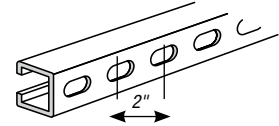

| CAT. NO. | DIM. (IN.) | GA. | STD. CTN. |
|-----------|------------|-----|-----------|
| A-1200-HS | 1½ x 1½ | 12 | * |
| B-1200-HS | 1½ x 1¾ | 12 | * |
| C-1200-HS | 1½ x 1½ | 12 | 500 |
| E-1200-HS | 1½ x 2¼ | 12 | 500 |
| H-1200-HS | 1½ x 3¼ | 12 | * |
| A-1400-HS | 1½ x 1½ | 14 | * |
| B-1400-HS | 1½ x 1¾ | 14 | 500 |

¼" x 1½" slots on 2" centers.

* Standard lengths 10 ft. and 20 ft. for standard cartons.
Please consult your local T&B representative.

Slotted Channel

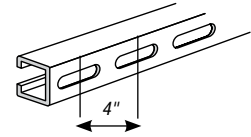

| CAT. NO. | DIM. (IN.) | GA. | STD. CTN. |
|----------|------------|-----|-----------|
| A-1200-S | 1½ x 1½ | 12 | * |
| B-1200-S | 1½ x 1¾ | 12 | * |
| A-1400-S | 1½ x 1½ | 14 | * |
| B-1400-S | 1½ x 1¾ | 14 | * |

¼" x 3" slots on 4" centers.

* Standard lengths 10 ft. and 20 ft. for standard carton.
Please consult your local T&B representative.

Punched Channel

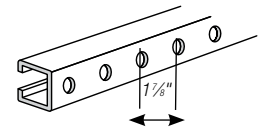

| CAT. NO. | DIM. (IN.) | GA. | STD. CTN. |
|----------|------------|-----|-----------|
| A-1200-P | 1½ x 1½ | 12 | 500 |
| B-1200-P | 1½ x 1¾ | 12 | 500 |
| H-1200-P | 1½ x 1¾ | 12 | 500 |
| A-1400-P | 1½ x 1½ | 14 | 500 |
| B-1400-P | 1½ x 1¾ | 14 | 500 |

¼" holes on 1 ⅛" centers.

Available in 10 & 20 ft. lengths.

Channel with Knockouts

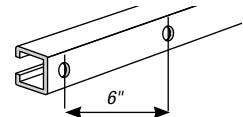

| CAT. NO. | DIM. (IN.) | GA. | STD. CTN. |
|-----------|------------|-----|-----------|
| A-1200-KO | 1½ x 1½ | 12 | * |
| A-1400-KO | 1½ x 1½ | 14 | * |

KO for ½" conduit.

Please consult your local T&B representative.

Standard Finish — GoldGalv® brand.

Threaded Products and Hardware

Trapnut® Strut Fastener

The unique scissor action of the Trapnut® Strut Fastener closes at any desired position on the threaded rod. Once closed, precision threads trap the threaded rod for a sturdy hold that can be adjusted up or down for fine-tune positioning. While the versatile Trapnut has a locking pin that holds it in the desired position, it can also be removed and reused.

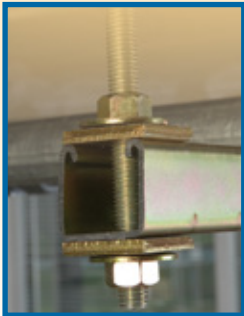

Standard method using nuts and washers.



New method using Trapnut® Strut Fastener.

Unlike a hex nut, there is no need to thread the Trapnut® from either end of the rod, saving valuable time on the job. While the Trapnut® Strut Fastener is a time-saver for new construction, it is invaluable for retro-fit applications. Rather than disassembling an existing trapeze to run additional conduit above it, the Trapnut® fastener can be clamped between the existing trapeze and the beam clamp for a speedy retro-fit solution. It's ideal for applications where the rod ends are not accessible.

The Trapnut® fastener has a sturdy steel construction that is load bearing, so you can be confident of a solid installation. And, the Trapnut® fastener functions as a hex nut, square washer and flat washer combined, so there are fewer parts to keep up with on the job.



CAT. NO. H 122 3/8
Trapnut® Strut
Fastener GoldGalv®



CAT. NO. H 122 3/8 EG
Trapnut® Strut
Fastener SilverGalv®

NEW!

ELECTRICAL
Contracting Products
2006 INNOVATION
AWARD WINNER

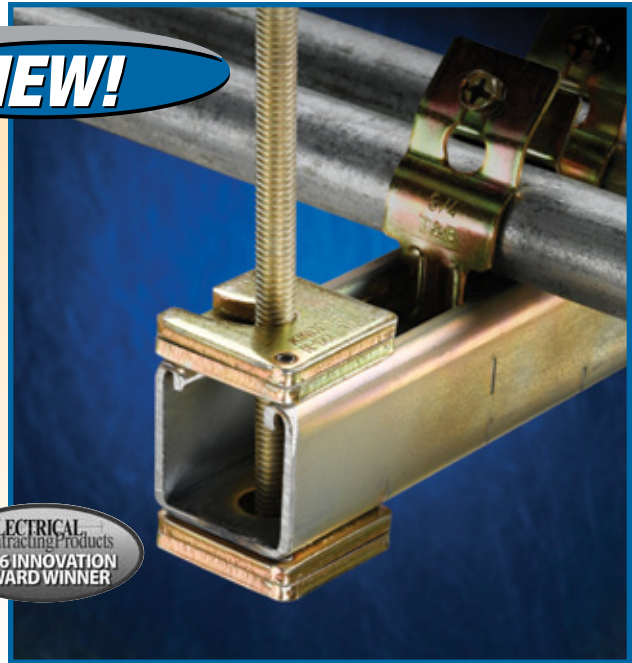

Easy to Install

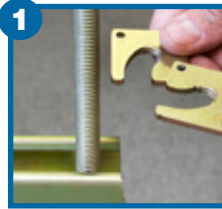

1 Hold in the open position.

- No need to thread the Trapnut® fastener from either end of the rod — saving valuable time
- Perfect for retro-fit applications where the rod ends are not accessible



2 Insert the bottom plate on the rod and close the top plate.

- Precision threads trap the threaded rod for a sturdy hold that can be adjusted up or down for fine-tune positioning
- Functions as a hex nut, square washer and flat washer combined

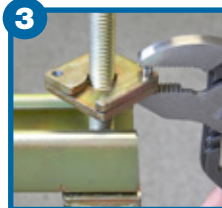

3 Press the pin with pliers.

- Locking pin holds it in the desired position
- Can be removed and reused

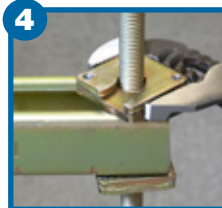

4 Tighten to the desired position with pliers.

- Can be adjusted up or down for fine-tuned positioning
- Sturdy steel construction that is load bearing
- Sized to provide custom fit for either 1 5/8" or 1 1/2" strut systems

| CAT. NO. | DESCRIPTION | DESIGN SIZE (IN.) | STD. LOAD LBS. | CTN. |
|---------------|-------------------------------|-------------------|----------------|------|
| H 122 1/4 | 1/4" GoldGalv® | 1/4 | 150 | 50 |
| H 122 3/8 | 3/8" GoldGalv® | 3/8 | 590 | 50 |
| H 122 1/2 | 1/2" GoldGalv® | 1/2 | 1,080 | 50 |
| H 122 1/4 EG | 1/4" SilverGalv® | 1/4 | 150 | 50 |
| H 122 3/8 EG | 3/8" SilverGalv® | 3/8 | 590 | 50 |
| H 122 1/2 EG | 1/2" SilverGalv® | 1/2 | 1,080 | 50 |
| H 122 1/4 SS6 | 1/4" Type 316 Stainless Steel | 1/4 | 150 | 50 |
| H 122 3/8 SS6 | 3/8" Type 316 Stainless Steel | 3/8 | 590 | 50 |
| H 122 1/2 SS6 | 1/2" Type 316 Stainless Steel | 1/2 | 1,080 | 50 |

Threaded Products and Hardware

Handle Retrofit Trapeze Applications with Ease!

Trap-Eze™ Connector

The innovative Trap-Eze™ Connector changes a time-consuming retrofit trapeze application into a streamlined process. Using a Trapnut® Strut Fastener, the new Trap-Eze™ Connector can be easily installed above or to the side of an existing assembly, eliminating the need to disassemble and reassemble the trapeze. It is designed for use with shorter strut lengths that can vary in length by as much as an inch, so the strut can be rough cut versus labor-intense precision cuts.

- Easily installs above or to the side of an existing assembly, eliminating the need to disassemble and reassemble the trapeze
- Connectors can be reused upon disassembly of a trapeze
- Designed for either 3/8" and 1/2" threaded rod
- Designed for use with the innovative Trapnut® Strut Fastener, which can take up to 43% less time than standard nuts and washers on retrofit trapeze applications
- View window provides safety zone for strut length

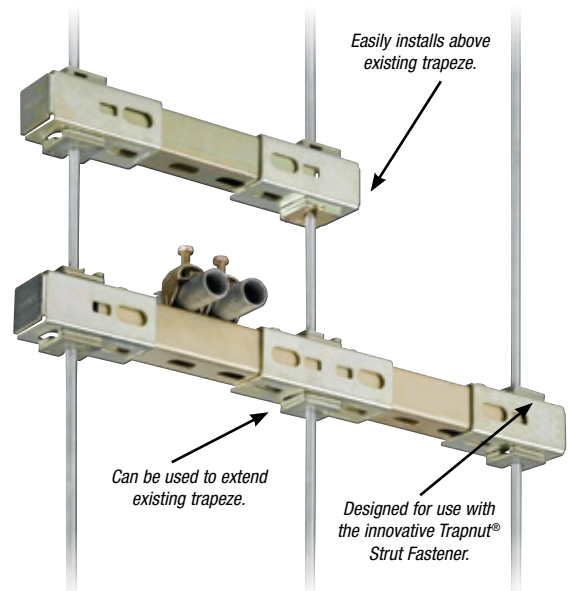

View window provides strut length safety zone for rough cuts versus precision cuts.

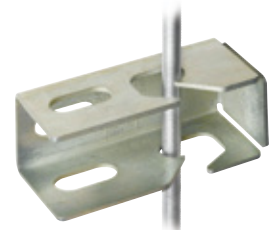

Unique safety slot maintains bracket position on threaded rod and prevents disengagement of the trapeze system.

| CAT. NO. | DESCRIPTION | STD. CTN. |
|--|-------------------------------------|-----------|
| For Superstrut® or other 1 1/4" Strut | | |
| AB221 | Trap-Eze™ End Connector GoldGalv® | 20 |
| AB222 | Trap-Eze™ Mid Connector GoldGalv® | 10 |
| AB221EG | Trap-Eze™ End Connector SilverGalv® | 20 |
| AB222EG | Trap-Eze™ Mid Connector SilverGalv® | 10 |
| For 1 1/2" Kindorf Channels | | |
| B998 | Trap-Eze™ End Connector Galv-Krom® | 20 |
| B999 | Trap-Eze™ Mid Connector Galv-Krom® | 10 |
| B998EG | Trap-Eze™ End Connector SilverGalv® | 20 |
| B999EG | Trap-Eze™ Mid Connector SilverGalv® | 10 |

Square Washer



AB-241

| CAT. NO. | BOLT SIZE (IN.) | STD. CTN. |
|-------------|-----------------|-----------|
| AB-241-1/4 | 1/4 | 100 |
| AB-241-5/16 | 5/16 | 100 |
| AB-241-3/8 | 3/8 | 100 |
| AB-241-1/2 | 1/2 | 100 |
| AB-241-5/8 | 5/8 | 100 |
| AB-241-3/4 | 3/4 | 50 |

Located Square Washer



AB-241L

| CAT. NO. | BOLT SIZE (IN.) | STD. CTN. |
|--------------|-----------------|-----------|
| AB-241L-1/4 | 1/4 | 100 |
| AB-241L-5/16 | 5/16 | 100 |
| AB-241L-3/8 | 3/8 | 100 |
| AB-241L-1/2 | 1/2 | 100 |
| AB-241L-5/8 | 5/8 | 100 |

Threaded Products and Hardware

Channel Nuts

Superstrut® channel nuts are manufactured from mild steel and are case hardened.

Design Data

Superstrut® self-aligning channel nuts are designed to provide resistance to pull out and resistance to side slip in excess of the full strength of the channels with which they are used. The extreme resistance to side slip results from the unique design of the alternate teeth, spaced and designed to develop a wedging action that increases with pressure or load.

Load Ratings for ¼", ⅜" and ½" Strut Nuts used in Superstrut®

| CHANNEL NUT SIZES (IN.) | SLIP TEST RATING | PULL TEST RATING |
|-------------------------|------------------|------------------|
| ¼ | 300 | 500 |
| ⅜ | 750 | 1,000 |
| ½ | 1,200 | 2,000 |

If connections will be subjected to dynamic or seismic loading conditions, contact the factory for design assistance.

1. All ratings have safety factor of 3 applied.
2. Load ratings are for Static Applications.

UC-100 Universal Cone Nut

Eliminates the inventory and installation hassles of conventional spring nuts. Fits all 1½" channel, regardless of depth, with a simple twist of your thumb. Pliable nylon cone secures the nut in place through the entire range of construction site temperatures.

Screw Threads

| | | | |
|--------------------------|----|----|----|
| THREAD SIZE (IN.) | ¼ | ⅜ | ½ |
| THREADS PER INCH | 20 | 16 | 13 |
| DESIGN TORQUE (FT.-LBS.) | 6 | 19 | 50 |

Standard Finish – GoldGalv®, unless otherwise stated.

All threaded products are American Standard thread, free fit class 2. GoldGalv® hardware finish is standard for all Superstrut® products. This is a multi-process finish of electro-plated zinc, followed by gold-colored trivalent chromium to give excellent corrosion resistance and a superior paint base. See **pages B-106–B-107** for a complete description of the GoldGalv® hardware finish.

Note: Standard Spring and Springless Nuts are supplied with a silver electro-galvanized (EG) finish. These items are not visible in a gold system and are universal with other systems' finishes and colorations.

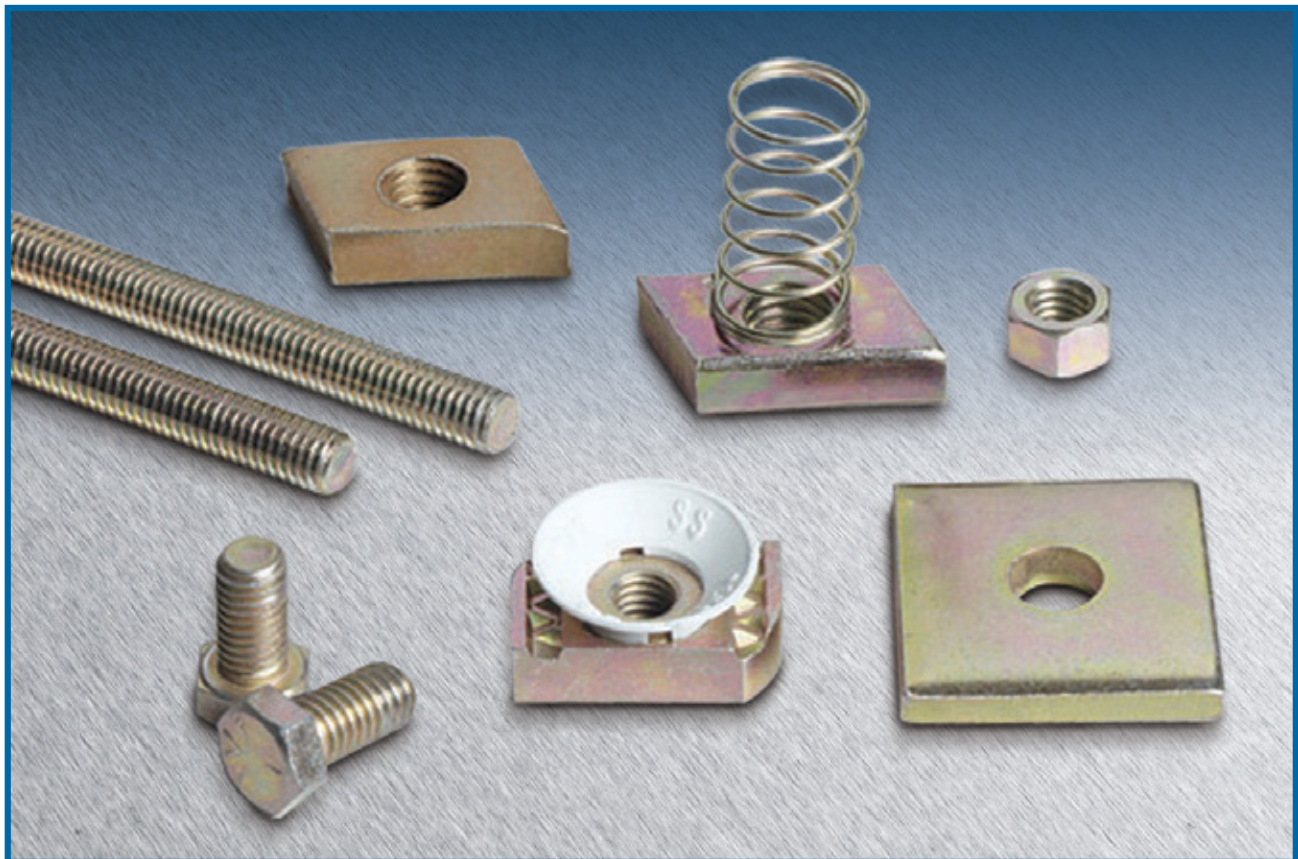

Threaded Products and Hardware

A-100 Regular Spring Nut

Sizes: 1/4", 5/16", 3/8", 1/2", 5/8", 3/4" & 1"

Nut is square over 1/2" size.
For all "A" and "C" series channel and inserts.



E-145 Standard Hex Nut

Sizes: 1/4", 3/8", 1/2", 5/8", 3/4", 7/8" & 1"

GoldGalv® Finish.



E-151-D Wood Screw Drive

Size A: 1/4"

Size B: 2"

Max. Rec. Load: 100 lbs.

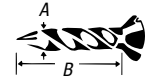

AB-100 Springless Nut

Sizes: 1/4", 5/16", 3/8", 1/2", 5/8" & 3/4"

Nut is square over 1/2" size.
For use with all channels.
Silver Electroplated Finish.

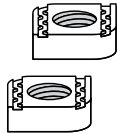

E-146 Standard Square Nut

Sizes: 1/4", 5/16", 3/8", 1/2" & 5/8"

GoldGalv® Finish.



ES-142 Seismic Stiffener Nut

Size: ES-142-1/2 x 1 1/2"

Bolt Dia.: 1/2"

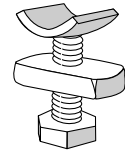

AC-100 Springless Nut

Sizes: 1/4", 3/8", 1/2", 5/8" & 3/4"

Nut is square over 1/2" size.
For all "A", "C", "E" and "H" series channel and inserts.

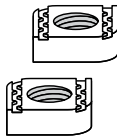

E-147 Flat Steel Washer

Sizes: 1/4", 5/16", 3/8", 1/2", 5/8", 3/4" & 7/8"

GoldGalv® Finish.



ES-145 Swivel Nut and Jam Nut Combinations

Sizes: 3/8" & 1/2"

GoldGalv® Finish.

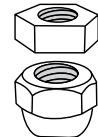

B-100 Short Spring Nut

Sizes: 1/4", 5/16", 3/8" & 1/2"

Nut is square over 1/2" size.
For all "B" series channel and inserts.

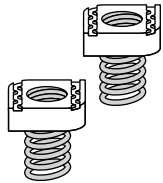

E-148 Lock Washer

Sizes: 1/4", 3/8", 1/2" & 5/8"

GoldGalv® Finish.



H-100 Long Spring Nut

Sizes: 3/8", 1/2" & 5/8"

Nut is square over 1/2" size.
For all "E" and "H" series channel and inserts.

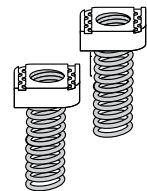

CM-100 Nylon Cone Nut

Sizes: 1/4", 3/8" & 1/2"

For all 1 1/2" channel.

*Will not fit "B" series channel.

GoldGalv® Finish



E-149 Slotted Hex Indented Head Machine Screw

Sizes: 1/4" x 3/4", 1/4" x 1", 5/16" x 1 1/4" & 3/8" x 1 1/4"

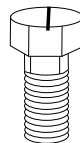

UC-100 Universal Nylon Cone Nut

Sizes: 1/4", 3/8" & 1/2"

For all 1 1/2" & 1 1/2" channels.
May be used with ALL strut depths. Can be used for CM-100, A-100, B-100 & AB-100 Series.

GoldGalv® Finish.



E-142 Hex Head Cap Screw

Sizes: 1/4" x 1", 1/4" x 1 1/2", 3/8" x 1", 3/8" x 1 1/2", 1/2" x 1 5/16" & 1/2" x 1 1/2"

See price sheet for additional sizes.



E-150-S Lag Bolt Screw

Size: 3/8" & 1/2"

Drill Size: 1/4" & 1 1/32"

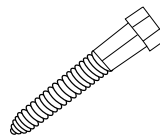

Threaded Products and Hardware

Fender Washer

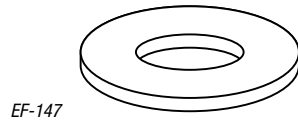

EF-147

| CAT. NO. | SIZE (IN.) | DIA. (IN.) | HOLE STD. (IN.) | STD. CTN. |
|------------|------------|------------|-----------------|-----------|
| EF147 1/4 | 1/4 | 1 1/4 | 3/16 | 100 |
| EF-147-3/8 | 3/8 | 1 1/2 | 7/16 | 100 |
| EF-147-1/2 | 1/2 | 2 | 3/8 | 100 |

Springless Stud Nut

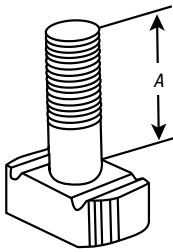

A-177 to A-180

| CAT. NO. | BOLT DIA. (IN.) | LENGTH A (IN.) | STD. CTN. |
|--------------------|-----------------|----------------|-----------|
| A177 1/4 1 | 1/4 | 1 | 50 |
| A-177-1/4 X 1-1/4 | 1/4 | 1 1/4 | 250 |
| A-179-3/8 X 1 | 3/8 | 1 | 250 |
| A-179-3/8 X 1-1/4 | 3/8 | 1 1/4 | 50 |
| A-180-1/2 X 1* | 1/2 | 1 | 250 |
| A-180-1/2 X 1-1/4* | 1/2 | 1 1/4 | 250 |

* Cannot be used with "B" Series channel.

Regular Spring Stud Nut

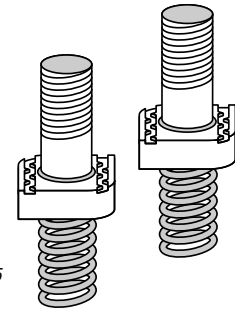

A-182 to A-185

| CAT. NO. | BOLT DIA. (IN.) | LENGTH A (IN.) | STD. CTN. |
|-------------------|-----------------|----------------|-----------|
| A182 1/4 1 | 1/4 | 1 | 250 |
| A-182-1/4 X 1-1/4 | 1/4 | 1 1/4 | 250 |
| A-184-3/8 X 1 | 3/8 | 1 | 50 |
| A-184-3/8 X 1-1/4 | 3/8 | 1 1/4 | 50 |
| A-185-1/2 X 1 | 1/2 | 1 | 50 |
| A-185-1/2 X 1-1/4 | 1/2 | 1 1/4 | 50 |

For all "A" and "C" series channels.

Standard Finish — GoldGalv®, unless otherwise stated.

Swivel Eye

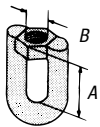

E-120

| CAT. NO. | A (IN.) | B (IN.) | DESIGN LOAD LBS. | STD. CTN. |
|----------|---------|---------|------------------|-----------|
| E120 3/8 | 1 3/8 | 3/8 | 1,000 | 25 |
| E120 1/2 | 1 1/2 | 1/2 | 1,800 | 25 |

Swivel Joint

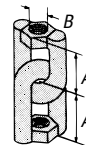

E-122

| CAT. NO. | A (IN.) | B (IN.) | DESIGN LOAD LBS. | STD. CTN. |
|-----------|---------|---------|------------------|-----------|
| E122 3/8 | 1 3/8 | 3/8 | 1,000 | 25 |
| E-122-1/2 | 1 1/2 | 1/2 | 1,800 | 10 |

Standard Finish — GoldGalv®, unless otherwise stated.

Swivel Eye with Stud

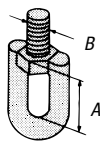

E-130

| CAT. NO. | A (IN.) | B (IN.) | DESIGN LOAD LBS. | STD. CTN. |
|-----------|---------|---------|------------------|-----------|
| E130 3/8 | 1 3/8 | 3/8 | 1,000 | 25 |
| E-130-1/2 | 1 1/2 | 1/2 | 1,800 | 25 |

Swivel Joint with Stud

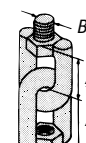

E-131

| CAT. NO. | A (IN.) | B (IN.) | DESIGN LOAD LBS. | STD. CTN. |
|-----------|---------|---------|------------------|-----------|
| E131 3/8 | 1 3/8 | 3/8 | 1,000 | 25 |
| E-131-1/2 | 1 1/2 | 1/2 | 1,800 | 10 |

Standard Finish — GoldGalv®, unless otherwise stated.

Threaded Products and Hardware

E-151 — Coach Screw Rod

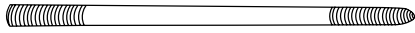

- Black available upon request
- Machine-threaded opposite end, carbon steel
- Order by Cat. No., rod size and rod length

| CAT. NO. | ROD SIZE (IN.) | STANDARD ROD LENGTHS | STD. CTN. |
|-----------|----------------|----------------------|-----------|
| E-151-3/8 | 3/8" | 4, 6, 8, 10, 12 | 100 |
| E-151-1/2 | 1/2" | 4, 6, 8, 10 | 100 |

H104-EG Hanger Rod, Continuous Thread — SilverGalv®



| CAT. NO. | SIZE | WT./LBS. PER 100 PCS. |
|----------------|---------|-----------------------|
| H104 1/4X6-EG | | 73 |
| H104 1/4X10-EG | 1/4"-20 | 124 |
| H104 1/4X12-EG | | 148 |
| H104 3/8X6-EG | | 172 |
| H104 3/8X10-EG | 3/8"-16 | 293 |
| H104 3/8X12-EG | | 348 |
| H104 1/2X6-EG | | 313 |
| H104 1/2X10-EG | 1/2"-13 | 530 |
| H104 1/2X12-EG | | 648 |
| H104 5/8X6-EG | | 510 |
| H104 5/8X10-EG | 5/8"-11 | 850 |
| H104 5/8X12-EG | | 1,020 |

Suffix indicates rod size and length.

H104 Hanger Rod, Continuous Thread — GoldGalv®

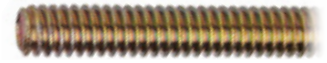

H-104 Series Rod



| CAT. NO. | SIZE | WT./LBS. PER 100 PCS. |
|-------------|---------|-----------------------|
| H104 1/4X6 | | 73 |
| H104 1/4X10 | 1/4"-20 | 124 |
| H104 1/4X12 | | 148 |
| H104 3/8X6 | | 172 |
| H104 3/8X10 | 3/8"-16 | 293 |
| H104 3/8X12 | | 348 |
| H104 1/2X6 | | 313 |
| H104 1/2X10 | 1/2"-13 | 530 |
| H104 1/2X12 | | 648 |
| H104 5/8X6 | | 510 |
| H104 5/8X10 | 5/8"-11 | 850 |
| H104 5/8X12 | | 1,020 |

Suffix indicates rod size and length.

Standard Rod Coupling

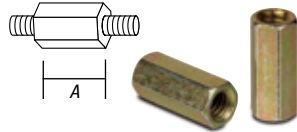

| CAT. NO. | ROD SIZE (IN.) | A (IN.) | STD. CTN. |
|-----------|----------------|---------|-----------|
| H119-1/4 | 1/4" | 7/8" | 50 |
| H119-5/16 | 5/16" | 7/8" | 50 |
| H119-3/8 | 3/8" | 1 1/8" | 50 |
| H119-1/2 | 1/2" | 1 1/4" | 50 |
| H119-5/8 | 5/8" | 2 1/8" | 50 |
| H119-3/4 | 3/4" | 2 1/4" | 50 |
| H119-7/8 | 7/8" | 2 1/2" | 50 |
| H119-1 | 1" | 2 3/4" | 50 |

Standard Finish — GoldGalv®, unless otherwise stated.

Reducing Rod Coupling

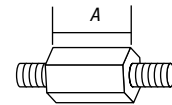

| CAT. NO. | ROD SIZE (IN.) | A (IN.) | STD. CTN. |
|--------------|----------------|---------|-----------|
| H119-1/4X3/8 | 1/4"-3/8" | 1 1/2" | 50 |
| H119-3/8X1/2 | 3/8"-1/2" | 1 1/4" | 50 |
| H119-1/2X5/8 | 1/2"-5/8" | 1 1/4" | 50 |
| H119-5/8X3/4 | 5/8"-3/4" | 1 1/2" | 50 |
| H119-3/4X7/8 | 3/4"-7/8" | 1 3/4" | 50 |

Standard Finish — GoldGalv®, unless otherwise stated.

U-571, U-572 Conduit Clamp

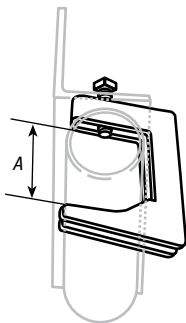

U-571, U-572

| CAT. NO. | CONDUIT SIZE (IN.) | MAX. FLANGE THICKNESS (IN.) | DIM. A (IN.) | STD. CTN. |
|----------|--------------------|-----------------------------|--------------|-----------|
| U-571 | 1/2" | 1 | 1 3/4" | 25 |
| U-571 | 3/4" | 3/4" | 1 3/4" | 25 |
| U-571 | 1" | 1/2" | 1 3/4" | 25 |
| U-572 | 3/4" | 1 1/2" | 2 1/2" | 25 |
| U-572 | 1" | 1 1/4" | 2 1/2" | 25 |
| U-572 | 1 1/4" | 1" | 2 1/2" | 25 |
| U-572 | 1 1/2" | 3/4" | 2 1/2" | 25 |

Standard Finish — GoldGalv® brand.

For attaching 1/2" thru 1 1/2" conduit to beam, channel, angle or column. Secures conduit to the support parallel or at right angles to it.

3/16" set screw, 12 ga. material.

Fittings and Brackets

Fittings and Brackets — Series 200



Material

Superstrut® fittings and brackets are manufactured from hot rolled carbon steel.

Dimensions

The following standard dimensions apply to all fittings except as indicated on the individual drawings.

- Hole spacing: $\frac{13}{16}$ " from end of fittings
- Hole spacing: $1\frac{1}{8}$ " centers
- Hole size: $\frac{9}{16}$ " diameter
- Material: $1\frac{1}{8}$ " wide
- Material: $\frac{1}{4}$ " thickness

Application Instructions

Parts drawings illustrate a typical use for the fitting, and in many cases other uses for the part are appropriate.

Design Data

Ratings vary when used with 12 or 14 gauge channel and are shown for each channel material.

GoldGalv® hardware finish is standard for all Superstrut® products. This is a multi-process finish of electro-plated zinc, followed by gold-colored trivalent chromium to give excellent corrosion resistance and a superior paint base. See **pages B-106–B-107** for complete description of the GoldGalv® hardware finish. GoldGalv® hardware will be furnished if no other finish is specified.

Nuts and Bolts Required

Unless otherwise noted, nuts and bolts for use with fittings and brackets should be ordered separately.

The standard bolt for the $\frac{9}{16}$ " hole is a $\frac{1}{2}$ " hex head cap screw $1\frac{5}{16}$ " long. The $1\frac{5}{16}$ " length may be used with all series channel.

Standard Finish – GoldGalv®, unless otherwise stated.

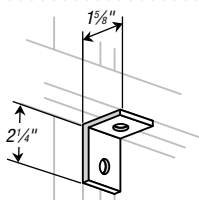

CAT. NO. AB201

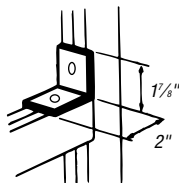

CAT. NO. AB202

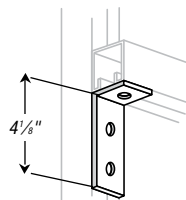

CAT. NO. AB203

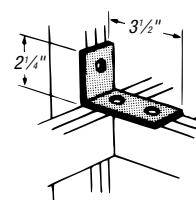

CAT. NO. AB204

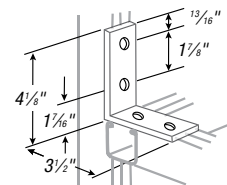

CAT. NO. AB205

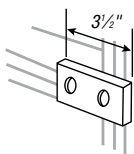

CAT. NO. AB206

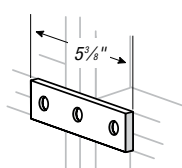

CAT. NO. AB207

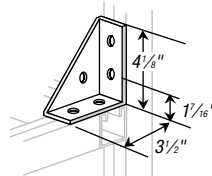

CAT. NO. AB213

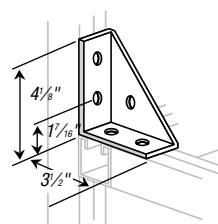

CAT. NO. AB214

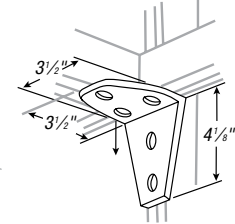

CAT. NO. AB216

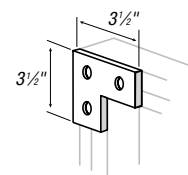

CAT. NO. AB219

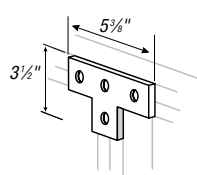

CAT. NO. AB220

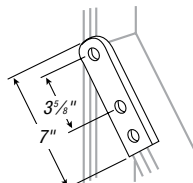

CAT. NO. AB240

Standard Dimensions

- Hole Spacing: $\frac{13}{16}$ " From End
- Hole Spacing: $1\frac{1}{8}$ " Centers
- Hole Size: $\frac{9}{16}$ " Diameter
- Material: $1\frac{1}{8}$ " Width
- Material: $\frac{1}{4}$ " Thick

Standard Finish – GoldGalv®, unless otherwise stated.
Add EG suffix for SilverGalv® Finish

Fittings and Brackets

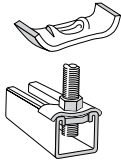

CAT. NO. AB-242
For use with either 3/8" or 1/2" hanger rod

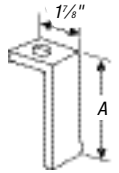

CAT. NO. AB252

| CAT. NO. | A (IN.) | STD. CTN. |
|----------|---------|-----------|
| AB252 1 | 3 7/8 | 10 |
| AB252 2 | 5 7/8 | 10 |
| AB252 3 | 7 7/8 | 10 |
| AB252 4 | 9 7/8 | 10 |

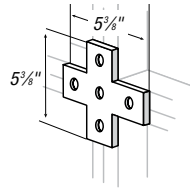

CAT. NO. AB253

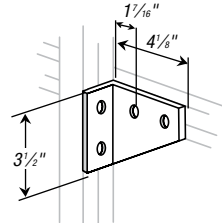

CAT. NO. AB254 L

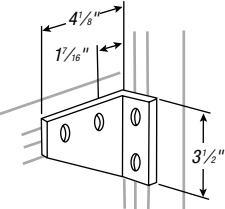

CAT. NO. AB254 R

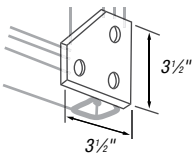

CAT. NO. AB255

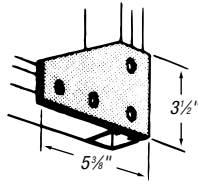

CAT. NO. AB257

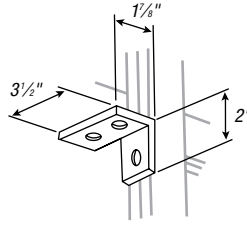

CAT. NO. AB260 L

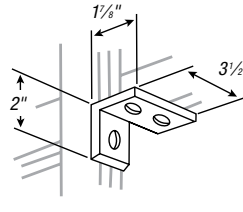

CAT. NO. AB260 R

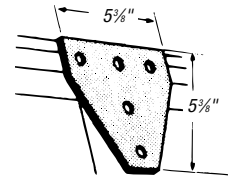

CAT. NO. AB261

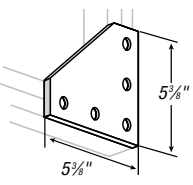

CAT. NO. AB263

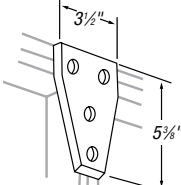

CAT. NO. AB265

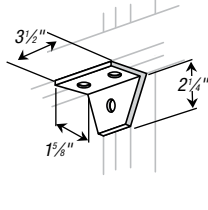

CAT. NO. AB274

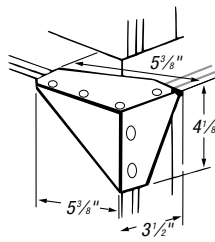

CAT. NO. AB284 L

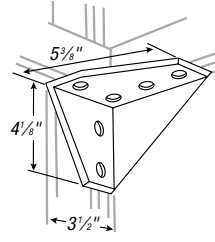

CAT. NO. AB284 R

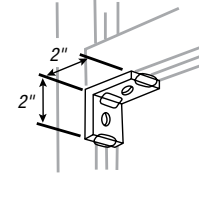

CAT. NO. AB299

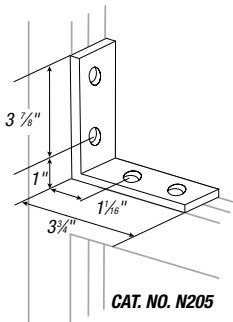

CAT. NO. N205

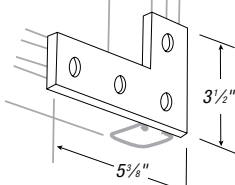

CAT. NO. N-219

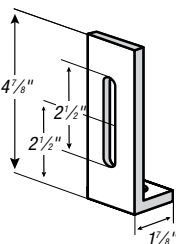

CAT. NO. X201

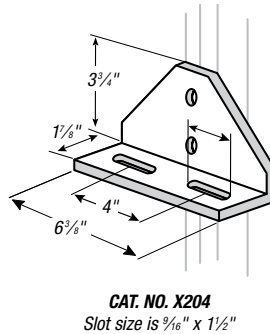

CAT. NO. X204
Slot size is 5/16" x 1 1/2"

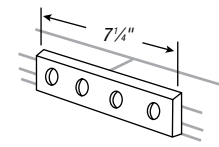

CAT. NO. X207

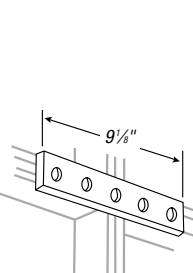

CAT. NO. X208

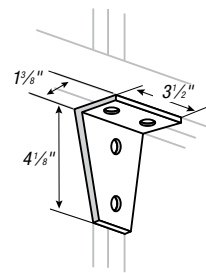

CAT. NO. X289

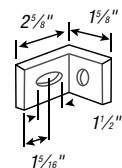

CAT. NO. X299

Standard Dimensions

- Hole Spacing: 1 3/16" From End
- Hole Spacing: 1 7/8" Centers
- Hole Size: 5/16" Diameter
- Material: 1 5/8" Width
- Material: 1/4" Thick

Standard Finish — GoldGalv®, unless otherwise stated.
Add EG suffix for SilverGalv® Finish

Fittings and Brackets

Z Shape Fittings

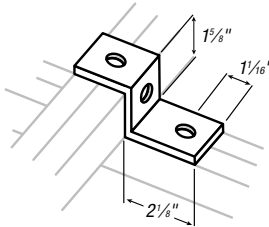

CAT. NO. A209
For attaching "A" series channel.

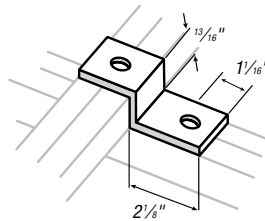

CAT. NO. B209
For attaching "B" series channel.

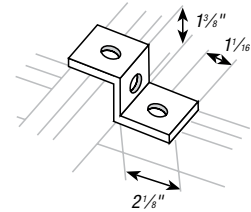

CAT. NO. C209
For attaching "C" series channel.

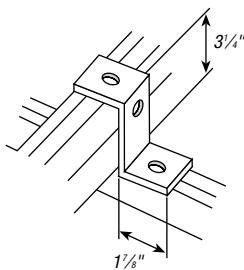

CAT. NO. GZ209
For attaching "A" back to back.

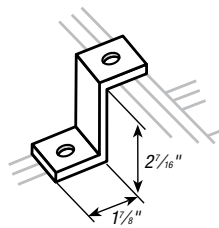

CAT. NO. EZ209
For attaching "E" series channel.

..... Standard Dimensions

- Hole Spacing: 1 1/16" From End
- Hole Spacing: 1 1/8" Centers
- Hole Size: 1" Diameter
- Material: 1 5/8" Width
- Material: 1/4" Thick

Standard Finish — GoldGalv®, unless otherwise stated.
Add EG suffix for SilverGalv® Finish

Wing Shape Fittings

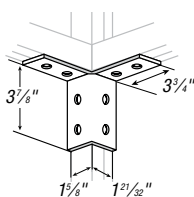

CAT. NO. A217

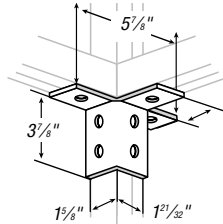

CAT. NO. A218

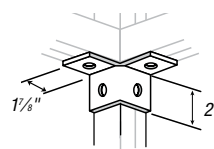

CAT. NO. AW204

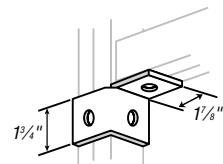

CAT. NO. AW205 L

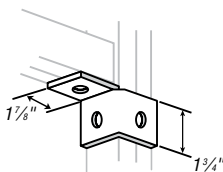

CAT. NO. AW205-R

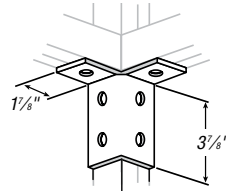

CAT. NO. AW214

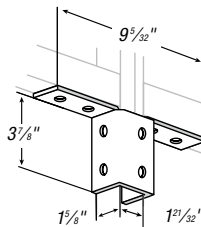

CAT. NO. AW219

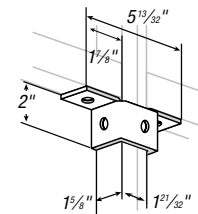

CAT. NO. AW220

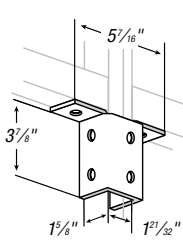

CAT. NO. AW224

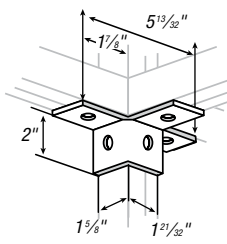

CAT. NO. AW226

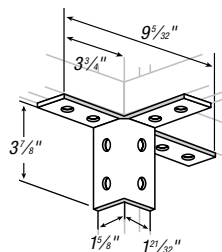

CAT. NO. AW228

..... Standard Dimensions

- Hole Spacing: 1 1/16" From End
- Hole Spacing: 1 1/8" Centers
- Hole Size: 1" Diameter
- Material: 1 5/8" Width
- Material: 1/4" Thick

Standard Finish — GoldGalv®, unless otherwise stated.
Add EG suffix for SilverGalv® Finish

Fittings and Brackets

U Shape Fittings

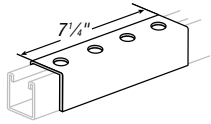

CAT. NO. A208
Does not include strut nut or bolts. For "A" series channel.

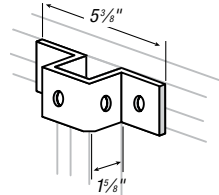

CAT. NO. A210
For attaching "A" series channel

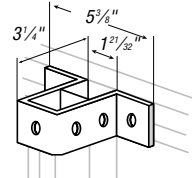

CAT. NO. A211
For attaching "A" series channel.

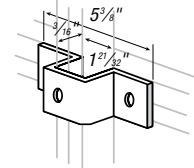

CAT. NO. B210

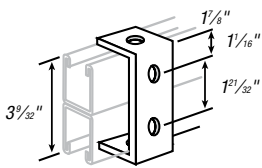

CAT. NO. AB245

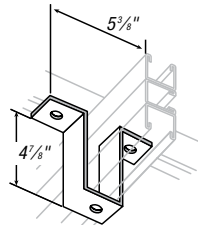

CAT. NO. AN211

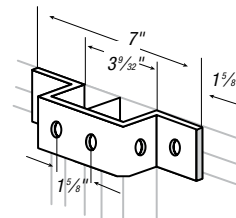

CAT. NO. A212

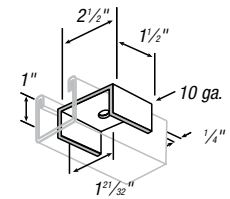

CAT. NO. AB-288

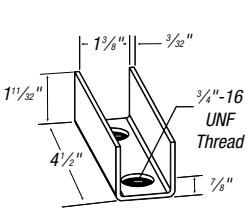

CAT. NO. A-213

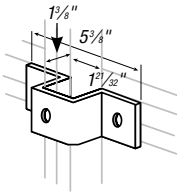

CAT. NO. C210
For attaching "C" series channel.

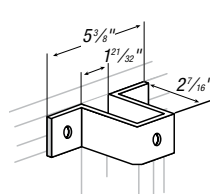

CAT. NO. E210
For attaching "E" series channel.

Standard Dimensions

- Hole Spacing: 1 3/16" From End
- Hole Spacing: 1 7/8" Centers
- Hole Size: 1" Diameter
- Material: 1 5/8" Width
- Material: 1/4" Thick

Standard Finish – GoldGalv®, unless otherwise stated.
Add EG suffix for SilverGalv® Finish

Angular Fittings

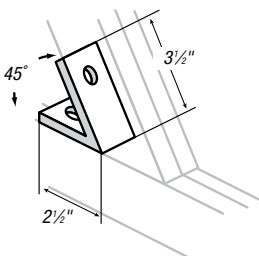

CAT. NO. AB225

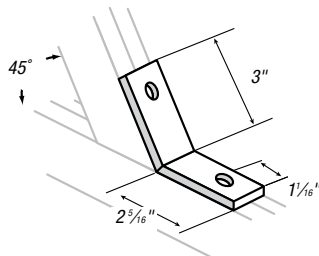

CAT. NO. AB227

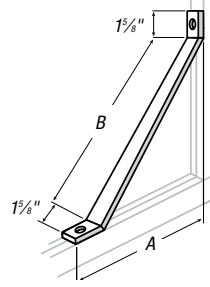

CAT. NO. AB-239

| CAT. NO. | A (IN.) | B (IN.) | STD. CTN. |
|----------|---------|---------|-----------|
| AB239 1 | 7 1/16 | 8 1/2 | 15 |
| AB-239-2 | 13 3/4 | 17 | 10 |
| AB-239-3 | 19 3/4 | 25 1/2 | 10 |

Standard Finish – GoldGalv®, unless otherwise stated.
Add EG suffix for SilverGalv® Finish

Fittings and Brackets

Post Bases

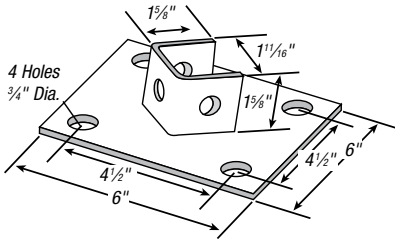

CAT. NO. AP-231

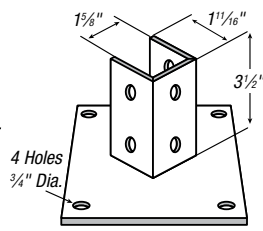

CAT. NO. AP-232

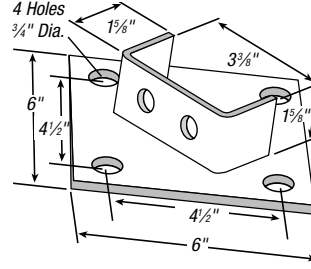

CAT. NO. AP-234

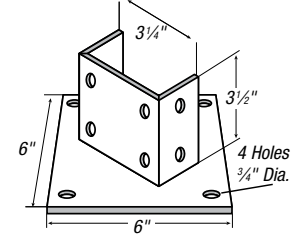

CAT. NO. AP-235

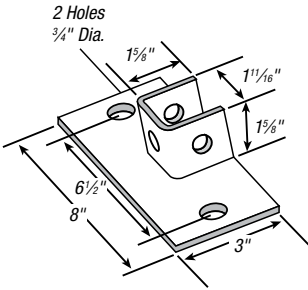

CAT. NO. AP-231FL

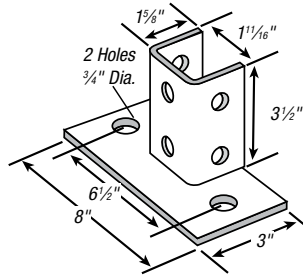

CAT. NO. AP-232FL

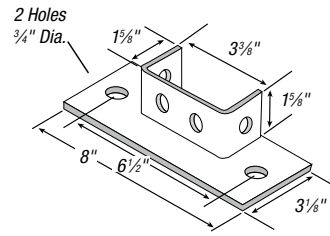

CAT. NO. AP-234FL

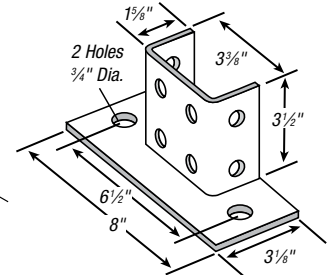

CAT. NO. AP-235FL

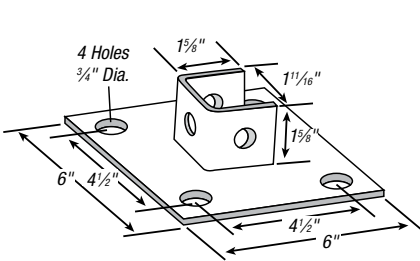

CAT. NO. AP-231SQ

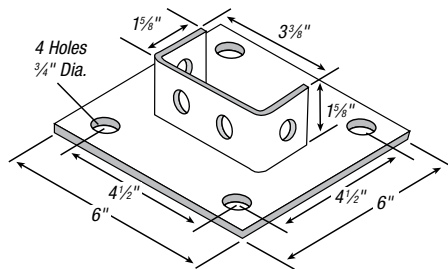

CAT. NO. AP-234SQ

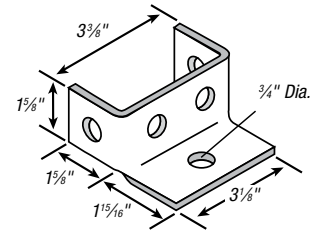

CAT. NO. AW-239

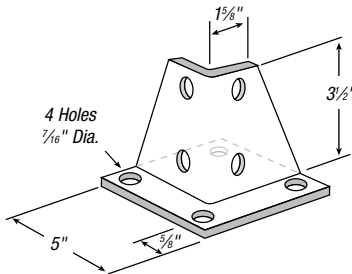

CAT. NO. AP-206

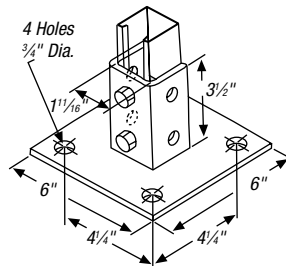

CAT. NO. AP-232SQ

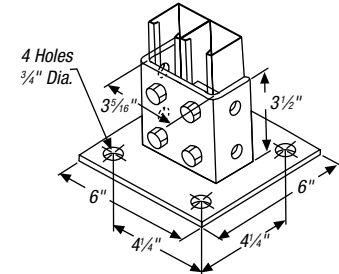

CAT. NO. AP-235SQ

Standard Finish – GoldGalv®, unless otherwise stated.
Add EG suffix for SilverGalv® Finish

Fittings and Brackets

Special Application Fittings

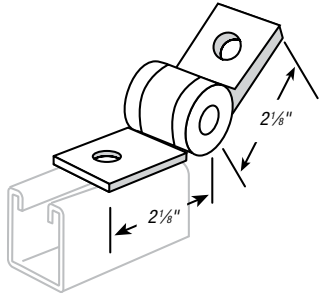

CAT. NO. Q202

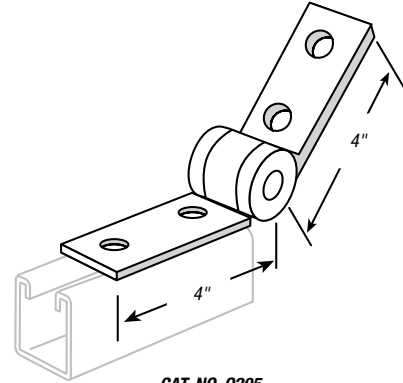

CAT. NO. Q205

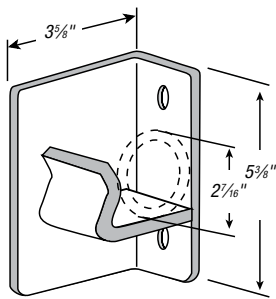

CAT. NO. Q255
For 2" standard pipe.
Load 1,500 lbs.

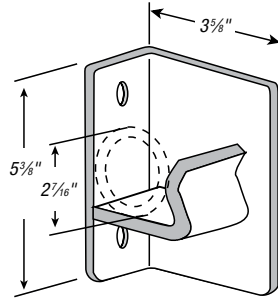

CAT. NO. Q256
For 2" standard pipe.
Load 1,500 lbs.

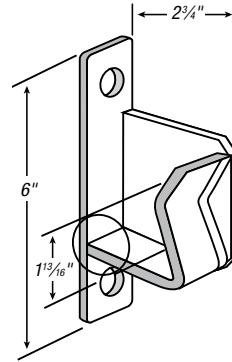

CAT. NO. Q253
For 1 1/4" standard pipe.
Load 1,500 lbs.

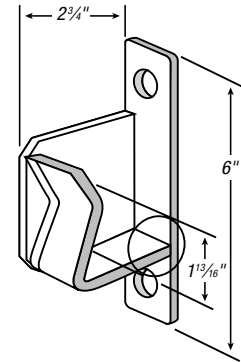

CAT. NO. Q254
For 1 1/4" standard pipe.
Load 1,500 lbs.

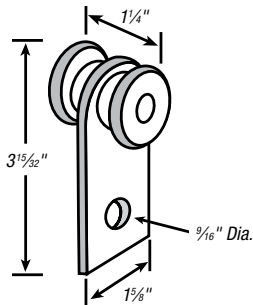

CAT. NO. TR292
Frictionless needle bearings.
Design load: 500 lbs.
Safety factor of 5.

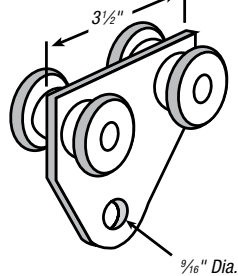

CAT. NO. TR294
Frictionless needle bearings.
Design load: 1,000 lbs.
Safety factor of 5.

.....Standard Dimensions.....

- Hole Spacing: 1 3/16" From End
- Hole Spacing: 1 7/8" Centers
- Hole Size: 9/16" Diameter
- Material: 1 5/8" Width
- Material: 1/4" Thick

Standard Finish – GoldGalv®, unless otherwise stated.
Add EG suffix for SilverGalv® Finish

Fittings and Brackets

Special Application Fittings (continued)

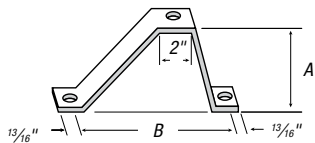

AN-270

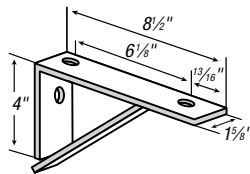

S204
Design Uniform Load/lbs.
A-1,200 650
A-1,400 500

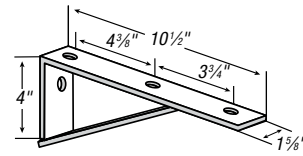

S205
Design Uniform Load/lbs.
A-1,200 650
A-1,400 500

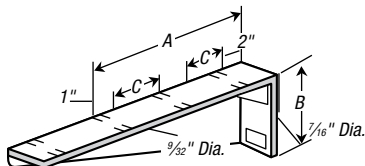

S-201-L and R
R as shown — L opposite hand.
12 ga. steel. Design Uniform Load/lbs.
A-1,200 250
A-1,400 200

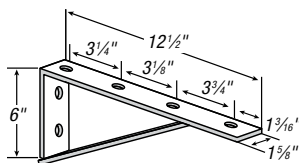

S217
Design Uniform Load/lbs.
A-1,200 750
A-1,400 650

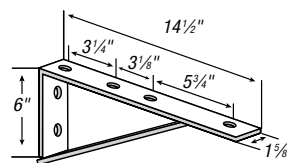

S218
Design Uniform Load/lbs.
A-1,200 750
A-1,400 650

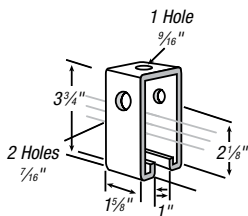

TS-272
Track Support
Requires 5/8" x 2 1/2" bolt and nut (not included).
Design load: 1,000 lbs.

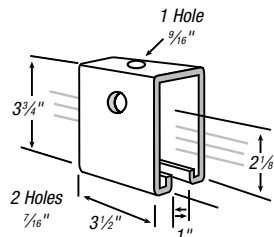

TS273
Track Support
For uses over channel splice. Requires 5/8" x 2 1/2" bolt and nut (not included).
Design load: 2,000 lbs.

Standard Finish — GoldGalv®, unless otherwise stated.
Add EG suffix for SilverGalv® Finish

..... Standard Dimensions

- Hole Spacing: 1 3/8" From End
- Hole Spacing: 1 7/8" Centers
- Hole Size: 9/16" Diameter
- Material: 1 1/8" Width
- Material: 1/4" Thick

| CAT. NO. | A (IN.) | B (IN.) | C (IN.) | STD. CTN. |
|-----------------|---------|---------|---------|-----------|
| S201-L6 or R6 | 6 | 1 1/8 | 3 | 25 |
| S201-L8 or R8 | 8 | 2 1/8 | 5 | 25 |
| S201-L10 or R10 | 10 | 2 5/8 | 7 | 5 |
| S201-L12 or R12 | 12 | 3 1/8 | 3 | 5 |
| S201-L14 or R14 | 14 | 3 5/8 | 4 | 5 |
| S201-L16 or R16 | 16 | 4 1/8 | 5 | 15 |
| S201-L18 or R18 | 18 | 4 5/8 | 6 | 5 |
| S201-L20 or R20 | 20 | 5 1/8 | 7 | 10 |

| CAT. NO. | A (IN.) | B (IN.) | STD. CTN. |
|----------|---------|---------|-----------|
| AN-270-1 | 2 3/8 | 6 | 10 |
| AN-270-2 | 4 3/8 | 8 | 10 |
| AN-270-3 | 6 3/8 | 10 | 10 |
| AN-270-4 | 8 3/8 | 12 | 15 |
| AN-270-5 | 10 3/8 | 14 | 10 |

Fittings and Brackets

Brackets

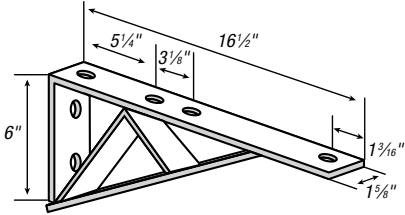

S222
Design Uniform Load/lbs.
A-1,200 1,000
A-1,400 750

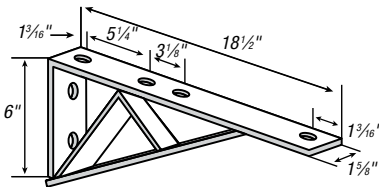

S226
Design Uniform Load/lbs.
A-1,200 1,000
A-1,400 750

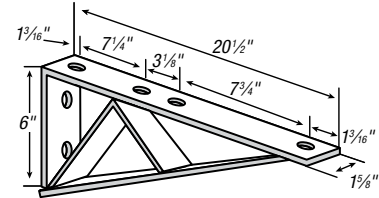

S236
Design Uniform Load/lbs.
A-1,200 800
A-1,400 650

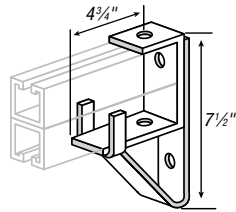

S248
Design Moment
(channel upright as shown)
When supported by
A-1,200 10,800 inch lbs.
A-1,400 7,550 inch lbs.
Applies to fitting only, not to the arm.
For
A-1,200
A-1,400

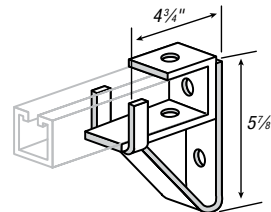

S247
Design Moment
(channel upright as shown)
When supported by
A-1,200 5,250 inch lbs.
A-1,400 3,650 inch lbs.
Applies to fitting only, not to the arm.
For
A-1,200 B-1,202
A-1,400 B-1,402

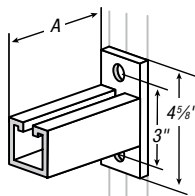

S-250
May be installed inverted with no change in load ratings. Strut section made from half slot channel.
Sizes: 6", 12", 18" & 24"

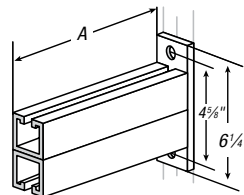

S-251
Strut section made from half slot channel.
Sizes: 12", 18", 24", 30" & 36"

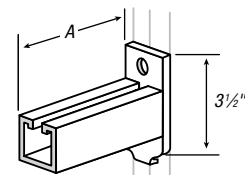

S-256
When installed in inverted position reduce load rating 40%.
Strut section made from half slot channel.
Sizes: 6", 12", 18" & 24"

| CAT. NO. | A (IN.) | DESIGN LOAD LBS. | STD. CTN. |
|----------|---------|------------------|-----------|
| S250 6 | 6 | 1,500 | 1 |
| S-250-12 | 12 | 800 | 1 |
| S-250-18 | 18 | 550 | 1 |
| S-250-24 | 24 | 400 | 1 |

| CAT. NO. | A (IN.) | DESIGN LOAD LBS. | STD. CTN. |
|----------|---------|------------------|-----------|
| S-251-12 | 12 | 1,650 | 1 |
| S-251-18 | 18 | 1,050 | 1 |
| S-251-24 | 24 | 800 | 1 |
| S-251-30 | 30 | 650 | 1 |
| S-251-36 | 36 | 500 | 1 |

| CAT. NO. | A (IN.) | DESIGN LOAD LBS. | STD. CTN. |
|----------|---------|------------------|-----------|
| S256 6 | 6 | 1,000 | 1 |
| S-256-12 | 12 | 500 | 1 |
| S-256-18 | 18 | 300 | 1 |
| S-256-24 | 24 | 250 | 1 |

Standard Finish GoldGalv®, unless otherwise stated.
Add EG suffix for SilverGalv® Finish

Concrete Inserts

Concrete Inserts (Series 300/400)

Standard lengths 10 ft. and 20 ft. length tolerance $\frac{3}{16}$ ". Assemblies available in any length from 12" to 20 ft. Consult factory.

Insert with end caps and foam filler strip installed.

Material:

B-302 and C-302 Insert Channel — 12 ga. steel.

B-804 and C-804 End Caps — 12 ga. steel.

Superstrut® continuous insert channel is cold formed from 12 gauge hot-rolled strip steel in two basic sizes as follows:

CAT. NO. B-302

$1\frac{5}{8}$ " x $1\frac{3}{16}$ " dim. $\frac{7}{8}$ " slot

CAT. NO. C-302

$1\frac{5}{8}$ " x $1\frac{1}{8}$ " dim. $\frac{7}{8}$ " slot

Finishes

Product is available in GoldGalv® pre-galvanized (PG), hot-dipped galvanized (HDG) and stainless steel (SS). Contact your T&B Sales team for delivery and pricing.

Standard lengths are 10 ft. and 20 ft. Product is supplied with foam filler and end caps to prevent seepage of concrete into channel.

Application

For casting into concrete walls, floors or ceilings to provide attachment anywhere along the continuous slot.

Design Data

Load ratings as shown have a safety factor of 3 in 3,000 lb. hard rock concrete. Where "good" concrete does not exist, the load ratings shall not apply.

GoldGalv® hardware finish is standard for all Superstrut® products. This is a multi-process finish of electro-plated zinc, followed by gold-colored trivalent chromium to give excellent corrosion resistance and a superior paint base. See pages B-106–B-107 for a complete description of the GoldGalv® hardware finish. GoldGalv® hardware will be furnished if no other finish is specified.

Standard Finish — GoldGalv®, unless otherwise stated.

Design Load lbs.

2,000 lbs. per foot in 3,000 lbs. hard rock concrete with a safety factor of 2.

NOTE: B-302 and C-302 are furnished with:

- A. Concrete safe tape applied to interior of channel to cover holes.
- B. Styrene insert between tape and $\frac{7}{8}$ " continuous opening.
- C. Two end caps on either side of strut to prevent concrete seepage.

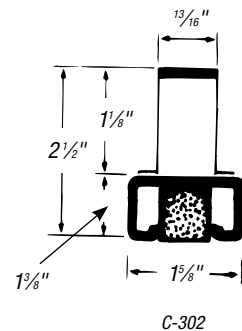
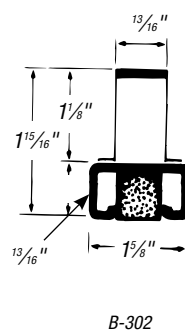
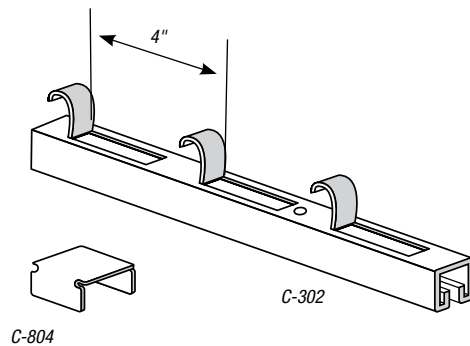
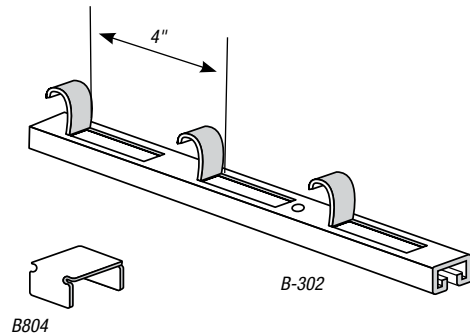
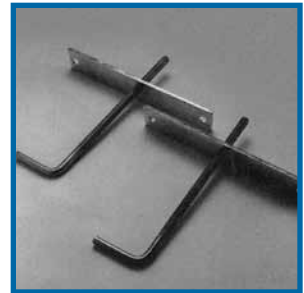
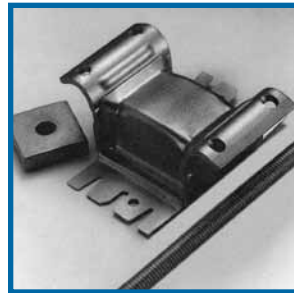

| CAT. NO. | DESCRIPTION |
|----------|---|
| B-302* | Insert channel 12 ga. steel — $1\frac{3}{16}$ " depth |
| C-302* | Insert channel 12 ga. steel — $1\frac{3}{8}$ " depth |
| B804 | End cap in B Series Concrete Insert |
| C-804 | End cap in C Series Concrete Insert |

*Add suffix -10 for 10' lengths and -20 for 20' lengths

Concrete Inserts

450 — End Cap

| CAT. NO. | FOR CHANNEL | X (IN.) | MATERIAL | STD. CTN. |
|----------|-------------|---------|----------|-----------|
| C-450TB | C-1,200 | 3 | 12 ga. | 100 |

Does not come in pairs, order number of total pieces required.

Inserts may be assembled from short pieces of channel by use of end caps.

Order closure strip separately.

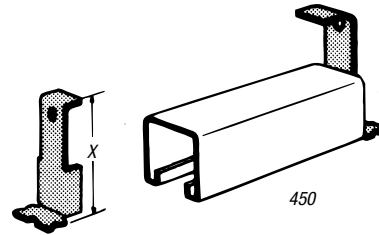

452-TB — Spot Insert — Top is Deep Drawn Cup

- An insert with a knockout saves covering the opening. Accommodates hanger rod sizes from 1/4" through 7/8" by means of an AB-102 insert nut
- Design load: 1,350 lbs. in 3,000 lb. hard rock concrete with a safety factor of 3
- Order AB-102 nut separately

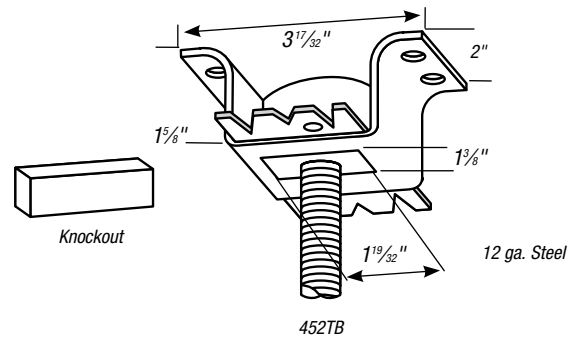

AB-102 — Unhardened Square Nut

| CAT. NO. | SIZE (IN.) | STD. CTN. |
|-------------|------------|-----------|
| AB102 1/4 | 1/4 | 50 |
| AB-102-3/8 | 3/8 | 100 |
| AB-102-1/2 | 1/2 | 100 |
| AB-102-5/8 | 5/8 | 50 |
| AB-1002-3/4 | 3/4 | 50 |
| AB-102-7/8 | 7/8 | 50 |

For use with Spot Insert Cat. No. 452.

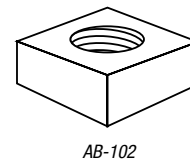

C475 — Metal Deck Ceiling Bolt

Metal Deck Ceiling Bolts are used with our Figure 123. Rod Couplings ordered separately. Made special to customer order.

Material: Steel

Finish: Standard Finish — GoldGalv®
 Black (add suffix "-B")
 Electro-Galvanized (add suffix "-EG")

Ordering: Specify size, dimension "A", catalog number and finish.

| CAT. NO. | WT. EACH | A (IN.) | B (IN.) | C (IN.) | MAX. LOAD (LBS.) |
|----------|----------|---------|---------|---------|------------------|
| C475 3/8 | .75 | S | 3/8 | 1 | 610 |
| C475 1/2 | .97 | P | 1/2 | 1 1/4 | 1,130 |
| C475 5/8 | 1.11 | e | 5/8 | 1 1/2 | 1,810 |
| C475 3/4 | 1.42 | c | 3/4 | 1 3/4 | 2,710 |
| C475 7/8 | 2.00 | i | 7/8 | 2 | 3,770 |
| C475 1 | 6 | f | 1 | 2 1/4 | 4,960 |
| | | y | | | |

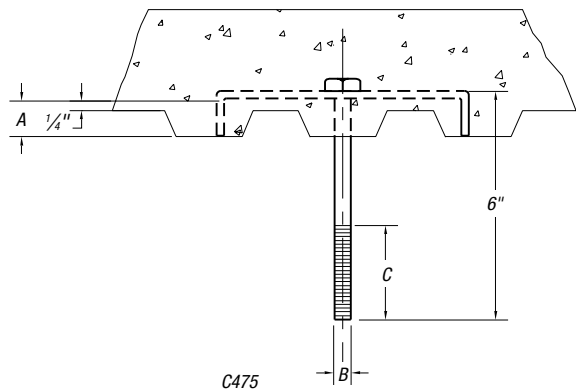

Beam Clamps

Superstrut® Beam Clamps

Materials

Most products are manufactured from hot-rolled carbon steel bars or hot-rolled strip steel. Pipe rollers are cast iron. Products which are copper plated carry the letter "T" in the prefix.

Design Loads

Where design loads are indicated, they provide for a safety factor of 3 in conformance with the "AMERICAN STANDARD CODE FOR PRESSURE PIPING."

GoldGalv® hardware finish is standard for all Superstrut® products. This is a multi-process finish of electro-plated zinc, followed by gold-colored trivalent chromium to give excellent corrosion resistance and a superior paint base. See **pages B-106–B-107** for a complete description of the GoldGalv® hardware finish. GoldGalv® hardware will be furnished if no other finish is specified.



Beam Clamps for Mounting Channel

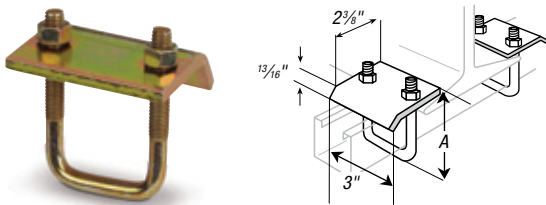

CAT. NO. U501, U502
Furnished complete.
Design load U501 – 2,150 lbs.
U502 – 3,000 lbs.

| CAT. NO. | FOR CHANNEL | A (IN.) | STD. CTN. |
|----------|---------------|---------------------------------|-----------|
| U501 | A-1200 A-1400 | 3 ⁵ / ₁₆ | 20 |
| | B-1200 B-1400 | | |
| | C-1200 B-1402 | | |
| U502 | A-1202 A-1402 | 4 ¹³ / ₁₆ | 20 |
| | C-1202 H-1200 | | |

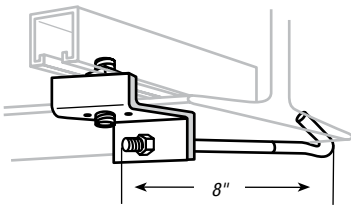

U504

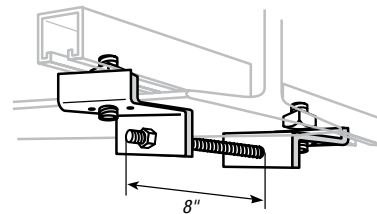

U505

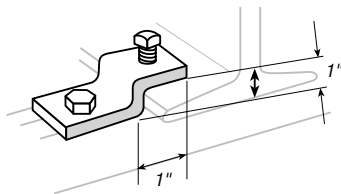

U510
¹/₂" x ¹/₂" set screw included.
Order separately one ¹/₂" x ¹/₂" hex head cap screw and ¹/₂" channel nut.

| Channel | Design Load lbs. |
|---------|------------------|
| A-1,200 | 1,000 |
| A-1,400 | 800 |

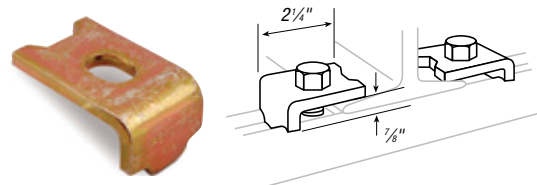

512-U
Order separately one ¹/₂" x ¹/₂" hex head cap screw and ¹/₂" channel nut.

| Channel | Design Load lbs. |
|---------|------------------|
| A-1,200 | 1,000 |
| A-1,400 | 800 |

Beam Clamps

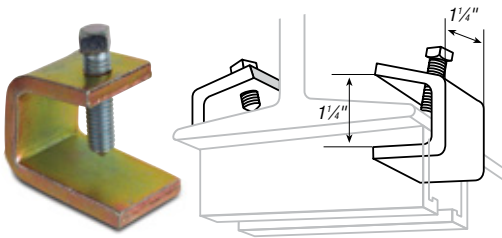

U514
3/8" x 1 1/2" set screw included.
Design load 750 lbs./per pair.

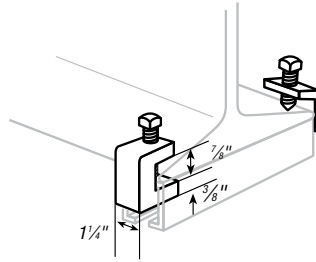

U514A
3/8" x 1 1/2" set screw included.
Design load 1,650 lbs./per pair.

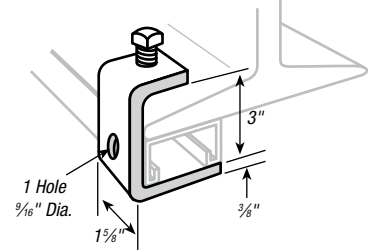

U515
For all "A" series channel.
1/2" x 1 1/2" set screw included.
Design load 800 lbs.

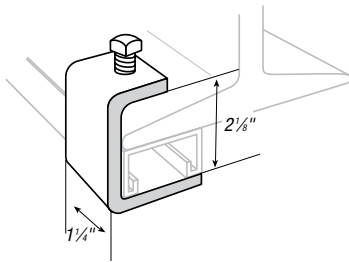

U515B
For all "B" series channel.
1/2" x 1 1/2" set screw included.
Design load 800 lbs.

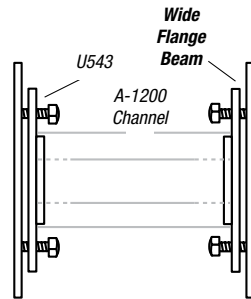

U543
Wide Flange Beam
A-1200 Channel

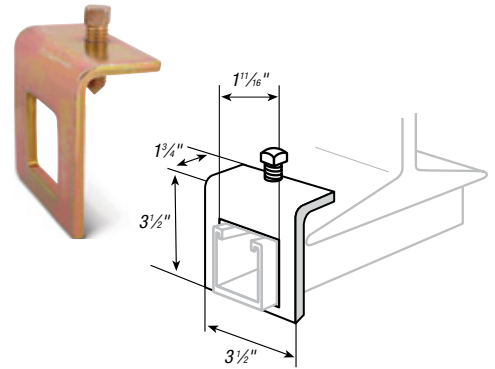

A-597
Standard Finish — GoldGalv® brand.
Channel Series A
Design load 800 lbs./ea.

| CAT. NO. | FLANGE WIDTH* (IN.) | A (IN.) | DESIGN LOAD LBS. | STD. CTN. |
|----------|---------------------|---------|------------------|-----------|
| U-520 | 2 3/8–4 1/2 | 8 3/4 | 2,000 | 10 |
| U-521 | 3 3/4–5 3/4 | 10 | 1,300 | 10 |
| U-522 | 5 5/8–7 5/8 | 11 1/8 | 900 | 10 |

*When ordering specify flange width.

Standard Finish — GoldGalv®, unless otherwise stated.

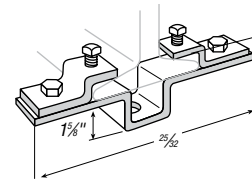

U520, U-521 & U-522
Standard Finish — GoldGalv® brand.
Nuts, cap screws and set screws included.

Beam Clamps

Beam Clamps — Malleable Iron, Silver Electroplated Finish

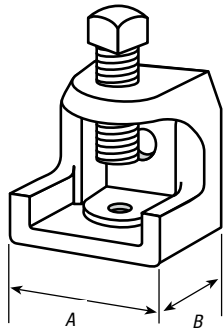

| CAT. NO. | BASE SIZE (IN.) | | JAW OPENING (IN.) | TAPPING OF BASE AND BACK HOLES | SET SCREW LOAD RATING† | TORQUE IN INCH-LBS. | STD. CTN. |
|----------|-----------------|----|-------------------|--------------------------------|------------------------|---------------------|-----------|
| | A | B | | | | | |
| 500-SC | 1 | 1¼ | 1⅞ | ¼-20 | 250 | 60 | 50 |
| 501 | 1½ | 1¾ | ⅞ | ⅝-18 | 500 | 60 | 50 |
| 502 | 2 | 2 | 1 | ⅝-16 | 750 | 120 | 50 |
| 503-SC | 2½ | 2½ | 1 | ½-13 | 1,250 | 250 | 20 |
| 507 | 2½ | 2¾ | 1¾ | ½-13 | 1,250 | 250 | 20 |
| 508 | 2½ | 2¾ | 2½ | ½-13 | 1,250 | 250 | 10 |
| 509 | 1 | 1¼ | 1⅞ | 10-24 | 150 | 60 | 100 |
| 510 | 2⅞ | 1¾ | ⅞ | ¼-20 | 250 | 40 | 100 |
| 511-SC | 2⅞ | 1¾ | ⅞ | 10-24 | 150 | 40 | 100 |

†Safety Factor of 3.

Load Ratings based on bottom hole of Beam Clamp.

CSA File No. LR-52208.

Also available in 316 stainless steel.

U-540 — Side Hanger Clip

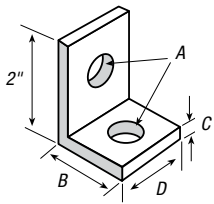

| CAT. NO. | A (IN.) | B (IN.) | C (IN.) | D (IN.) | STD. CTN. |
|------------|---------|---------|---------|---------|-----------|
| 540 3/8 | ⅞ | 1⅞ | ¼ | ⅞ | 25 |
| 540 1/2 EC | ⅞ | 1⅞ | ¼ | 1⅞ | 25 |
| 540-5/8 | 1⅞ | 2½ | ⅜ | 2 | 25 |
| 540-3/4 | 1⅞ | 2½ | ⅜ | 2 | 25 |

Finishes — GoldGalv® brand or Black (B)

U-542 — Side Hanger Clip

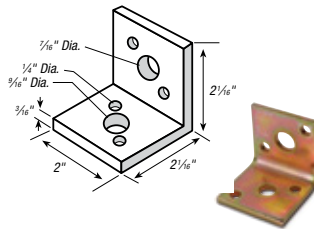

| CAT. NO. | ROD SIZE | DESIGN LOAD (LBS.) |
|----------|----------|--------------------|
| 544 | ⅜" | 610 |
| | ½" | 1,000 |

Finishes — GoldGalv® brand or Black (B) Standard Finish — GoldGalv®, EG, HD, & SS available.

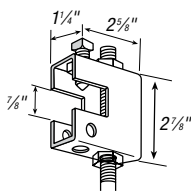

U562
Beam Clamp
½" set screw included.
Rod Size: ½"
Design load 500 lbs.

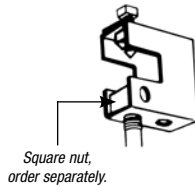

U562
Beam Clamp Optional Use
½" set screw included.
Rod size: ½"
Design load 800 lbs.
For 20° swivel application, use ES-145-1/2 nut.

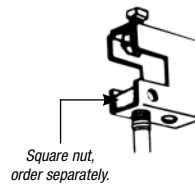

U563
Beam Clamp Optional Use
⅜" set screw included.
Rod size: ⅜"
Design load 400 lbs.

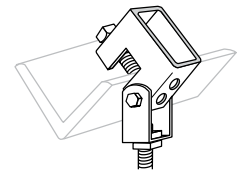

U563
Beam Clamp with Swing Hanger
⅜" set screw included.
Rod sizes: ⅜"
Design load 540 lbs.

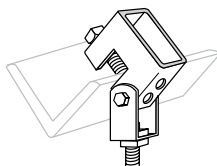

U562
Beam Clamp with Swing Hanger
½" screw included.
Rod size: ½"
Design load 800 lbs.

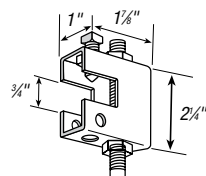

U563
Beam Clamp
⅜" set screw included.
Rod size: ⅜"
Design load 250 lbs.

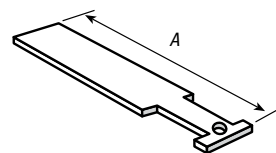

U-568
Beam Clamp Safety Strap
Standard Finish — GoldGalv® brand
For U-563 beam clamp.

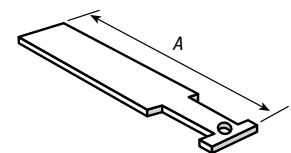

U-568
Beam Clamp Safety Strap
Standard Finish — GoldGalv® brand
For U-562 beam clamp.

Beam Clamps

S-541 — Swing Connector

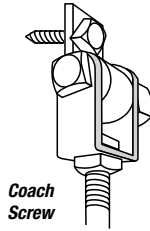

Coach
Screw

Standard Finish — GoldGalv® brand
Rod Size: $\frac{3}{8}$ "
For use with wood beam.
 $\frac{3}{8}$ " x $1\frac{1}{4}$ " bolt, nut and clevis included.

U-577 — Clevis & Swing Connector

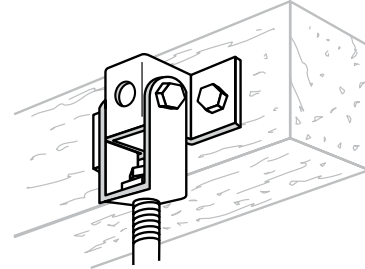

Rod Size: $\frac{1}{2}$ "
Standard Finish — GoldGalv® brand
For use with wood beam.

U-560 — Heavy-Duty Beam Clamp

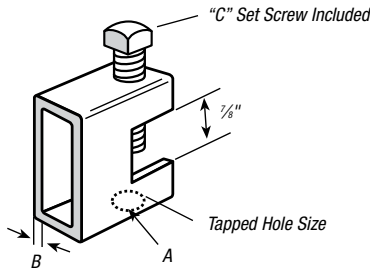

| CAT. NO. | DIMENSIONS (IN.) | | | DESIGN LOAD LBS. | STD. CTN. |
|-----------|------------------|---------------|--------------------------------|------------------|-----------|
| | A | B | C | | |
| U560 1/4 | $\frac{1}{4}$ | $\frac{1}{8}$ | $\frac{3}{8}$ x $1\frac{1}{2}$ | 1,050 | 25 |
| U-560-3/8 | $\frac{3}{8}$ | $\frac{1}{8}$ | $\frac{3}{8}$ x $1\frac{1}{2}$ | 1,050 | 25 |
| U-560-1/2 | $\frac{1}{2}$ | $\frac{1}{4}$ | $\frac{1}{2}$ x $1\frac{1}{2}$ | 2,650 | 25 |
| U-560-5/8 | $\frac{5}{8}$ | $\frac{1}{4}$ | $\frac{1}{2}$ x $1\frac{1}{2}$ | 2,650 | 25 |

Channel Angle Connector. Standard Finish — GoldGalv®.

Available in Electro-Galvanized (EG) finish.

Integral pilot, prevents twist.

U-564 — Heavy-Duty Beam Clamp

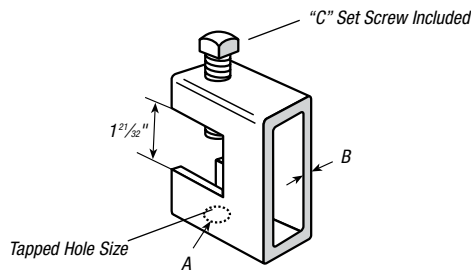

| CAT. NO. | DIMENSIONS (IN.) | | | DESIGN LOAD LBS. | STD. CTN. |
|-----------|------------------|---------------|--------------------------------|------------------|-----------|
| | A | B | C | | |
| U-564-3/8 | $\frac{3}{8}$ | $\frac{1}{4}$ | $\frac{3}{8}$ x $2\frac{1}{4}$ | 1,300 | 25 |
| U-564-1/2 | $\frac{1}{2}$ | $\frac{1}{4}$ | $\frac{1}{2}$ x $2\frac{3}{4}$ | 3,150 | 15 |
| U564 5/8 | $\frac{5}{8}$ | $\frac{1}{4}$ | $\frac{1}{2}$ x $2\frac{3}{4}$ | 3,150 | 25 |

Available in Electro-Galvanized (EG) finish.

Beam Clamps

E-231 — Structural Steel Clamp



| CAT. NO. | DIMENSIONS (IN.) | | | WT. LBS./C |
|-------------------------|------------------|-------|--------|------------|
| | A | B | C | |
| <i>3/8" or 1/2" Rod</i> | | | | |
| *E-231-3/8 | 2 1/2 | 1 | 7/8 | 31 |
| **E-231-1/2 | 3 | 1 1/2 | 1 5/16 | 53 |

Assembly requires two H-116-C (3/8") or two H-116-D (1/2") square nuts to attach hanger rod. 1/2" steel.

* Load rating of 500 lbs. with a safety factor of 3.

** Load rating of 800 lbs. with a safety factor of 3.

Standard Finish — GoldGalv®, unless otherwise stated.

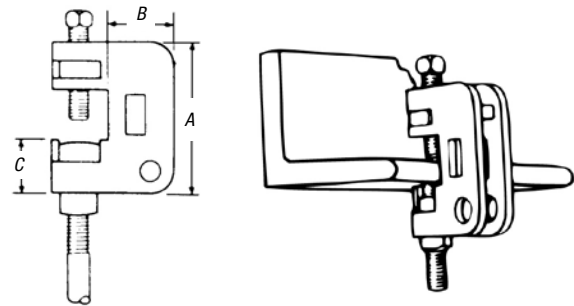

E-232 — Clamp with Swing Connector

- E-231 clamp with swing connector
- Affords a convenient method of attaching to angled beams



| CAT. NO. | DIAMETER FOR ROD (IN.) | DIMENSIONS (IN.) | | | WT. LBS./C |
|-------------------------|------------------------|------------------|--------|-------|------------|
| | | A | B | C | |
| <i>3/8" or 1/2" Rod</i> | | | | | |
| *E-232-3/8 | 3/8 | 3/16 | 7/16 | 1 | 48 |
| **E-232-1/2 | 1/2 | 7/8 | 2 3/16 | 1 1/2 | 76 |

* Load rating of 400 lbs. with a safety factor of 3.

** Load rating of 550 lbs. with a safety factor of 3.

GoldGalv® finish.

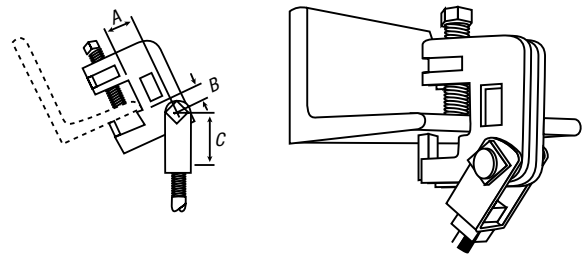

E-233 — Anchor Clip

- Clamps to I-beams, channels, angles and column
- Two sizes are available, one for 3/8" and the other for 1/2" hanger rod
- Each takes flanges up to .8" thickness



| CAT. NO. | ROD SIZE (IN.) | MAX. BEAM WIDTH "A" (IN.) | FOR USE WITH | WT. LBS./C |
|--------------|----------------|---------------------------|------------------------|------------|
| E-233-3/8-6 | 3/8 | 6 | E-231-3/8 or E-232-3/8 | 20 |
| E-233-3/8-10 | 3/8 | 10 | E-231-3/8 or E-232-3/8 | 33 |
| E-233-1/2-6 | 1/2 | 6 | E-231-1/2 or E-232-1/2 | 26 |
| E-233-1/2-10 | 1/2 | 10 | E-231-1/2 or E-232-1/2 | 37 |

Anchor Clips should be used when clamps are subject to excessive vibration. To obtain the correct size clips, add 1 inch to the flange width. If length required is not standard, order next largest standard length.

GoldGalv® finish.

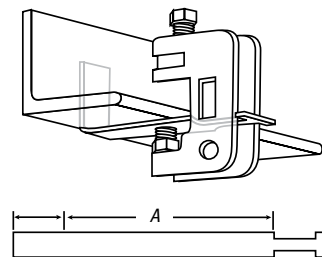

For use with E-231 and E-232 clamps when hanger rod is not in straight through position.

Beam Clamps

E-160 — Adjustable Beam Clamp

- Clamps to I-beam where edge of beam flange does not exceed .8" thickness
- Hook rod is furnished in three lengths to fit beam flanges up to 6", 9" or 12" widths



| CAT. NO. | BEAM FLANGE WIDTH (IN.) | WT. LBS./C |
|-------------------------|-------------------------|------------|
| 1/2" HANGER RODS | | |
| 1/2" Rod | | |
| E-160-1/2-6 | 2½ to 6 | 115 |
| E-160-1/2-9 | 5½ to 9 | 125 |
| E-160-1/2-12 | 8½ to 12 | 154 |

Load rating 800 lbs. with a safety factor of 3.

Assembly requires hanger rod of the proper length and size plus two H-114-D nuts 3/16" steel and 1/2" hook rod.

GoldGalv® finish.

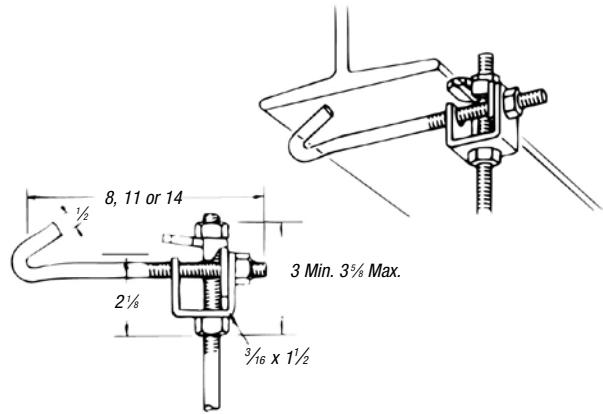

U-568 Beam Clamps

| CAT. NO. | BEAM FLANGE WIDTH (IN.) | A (IN.) | STD. CTN. |
|----------|-------------------------|---------|-----------|
| U568 1 | 6 | 8 | 50 |
| U-568-2 | 9 | 11 | 50 |
| U-568-3 | 6 | 9 | 25 |
| U-568-4 | 9 | 12 | 50 |
| U-568-5 | 12 | 15 | 50 |
| U-568-6 | 6 | 9 | 25 |
| U-568-7 | 9 | 12 | 25 |
| U-568-8 | 12 | 15 | 25 |

16 ga. material.

Standard Finish — GoldGalv®, unless otherwise stated.

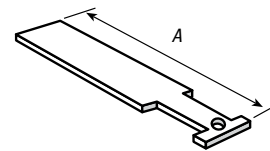

U-568

Beam Clamp Safety Strap
Standard Finish — GoldGalv® brand.
For U-560 and U-564 beam clamp.

U569 — Beam Clamp

- Standard finish — GoldGalv®
- Maximum flange width 5"
- Design load 400 lbs.

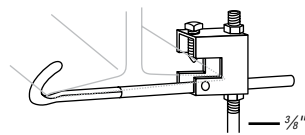

U570 — Beam Clamp with Safety Rod

- Standard finish — GoldGalv®
- Flange width 4" min. – 8" max.
- Sizes — 1/2" (for use with 3/8" rod, see U569)
- Design load 650° F – 500 lbs.

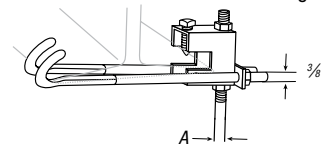

C-775L — Clamp with Lock Nut

| CAT. NO. | ROD SIZE (IN.) | DIMENSIONS (IN.) | | | | DESIGN LOAD LBS. | STD. CTN. |
|------------|----------------|------------------|-----|--------|-------|------------------|-----------|
| | | A | B | C | D | | |
| C775L 3/8 | 3/8 | 3/8 | 3/4 | 2 1/2 | 2 3/8 | 400 | 100 |
| C-775L-1/2 | 1/2 | 3/8 | 3/4 | 2 3/8 | 2 3/8 | 500 | 100 |
| C-775L-5/8 | 5/8 | 1/2 | 3/4 | 2 5/16 | 2 3/8 | 550 | 50 |
| C-775L-3/4 | 3/4 | 5/8 | 3/4 | 2 5/16 | 2 3/8 | 630 | 50 |
| C-775L-7/8 | 7/8 | 3/4 | 1 | 3 1/16 | 3 | 1,200 | 25 |

Standard Finishes - GoldGalv® brand, Black (B), Stainless Steel (SS) and Electro-Galvanized (EG).

Carbon Steel.



C-775L

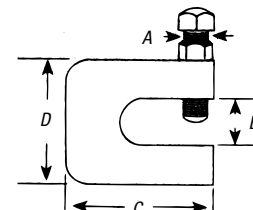

Beam Clamps

C-777 — Steel Top Beam Clamp & C-778 — Steel Wide Jaw Top Beam Clamp

| CAT. NO. | ROD SIZE A (IN.) | PIPE SIZE | DIMENSIONS (IN.) | | | | | DESIGN LOAD LBS. | STD. CTN. |
|-----------|------------------|-----------|------------------|-------|---|------|-------|------------------|-----------|
| | | | B | C | D | E | F | | |
| C777 3/8 | 3/8 | 1/2-4 | 1 1/16 | 3/4 | 1 | 7/16 | 1 | 900 | 100 |
| C-777-1/2 | 1/2 | 5-8 | 1 1/2 | 3/4 | 1 | 9/16 | 1 1/4 | 2,430 | 50 |
| C-778-3/8 | 3/8 | 1/2-4 | 1 3/16 | 1 1/4 | 1 | 7/16 | 1 | 900 | 100 |
| C-778-1/2 | 1/2 | 5-8 | 1 1/2 | 1 1/4 | 1 | 9/16 | 1 1/4 | 2,430 | 50 |

Standard Finish — GoldGalv®, Black (B) and Electro-Galvanized (EG).

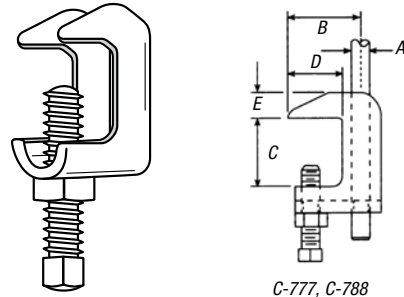

C-777, C-788

M-777 — Steel Top Beam Clamp

- Junior Top Beam C-Clamp
- Standard finish is Gold-Galv®
- Available in Electro-Galvanized (EG) or Black (B) Malleable Iron
- Provides clamping under roof installations with bar joist construction (max. joist thickness 5/8")
- Order by Cat. No., rod size

| ROD SIZE A (IN.) | DESIGN LOAD LBS. |
|------------------|------------------|
| 3/8 | 350 |
| 1/2 | 470 |
| 5/8 | 550 |
| 3/4 | 700 |
| 7/8 | 1,000 |

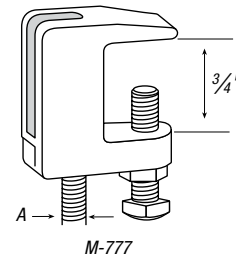

M-777

M-775L — Clamp with Lock Nut

| CAT. NO. | ROD SIZE A (IN.) | B (IN.) | C (IN.) | DESIGN LOAD LBS. | STD. CTN. |
|------------|------------------|---------|---------|------------------|-----------|
| M-775L-3/8 | 3/8 | 3/4 | 1 3/4 | 400 | 100 |
| M-775L-1/2 | 1/2 | 3/4 | 1 3/4 | 400 | 100 |
| M-775L-5/8 | 5/8 | 3/4 | 2 | 440 | 50 |
| M-775L-3/4 | 3/4 | 3/4 | 2 | 500 | 50 |

Available in Electro-Galvanized (EG) or Black (B).

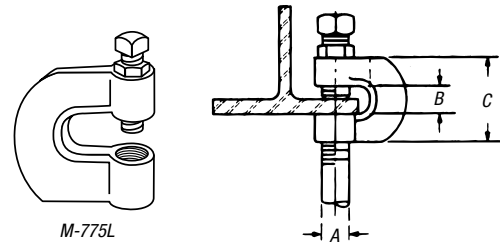

M-775L

M-778 — Steel Wide Jaw Top Clamp

- Top Beam C-Clamp
- Rod Size: 3/8", 1/2", 5/8" and 3/4"
- Available in Electro-Galvanized (EG) or Black (B) Malleable Iron
- Provides clamping under roof installations with bar joist type construction
- Order by Cat. No. and rod size

| ROD SIZE A (IN.) | DESIGN LOAD LBS. |
|------------------|------------------|
| 3/8 | 400 |
| 1/2 | 500 |
| 5/8 | 850 |
| 3/4 | 900 |

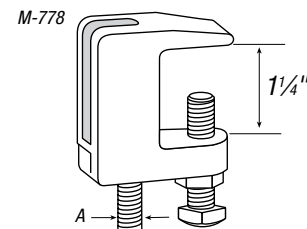

Beam Clamps

C-247, C-248 & C-249 — Steel Conduit Clamps

- A versatile clamp for attaching conduit to any type of beam, channel, angle or column
- Designed to hold the conduit snug against the support with conduit either parallel or at right angle to it
- The case-hardened set screw bites into the structural member for maximum security
- 1/8" steel

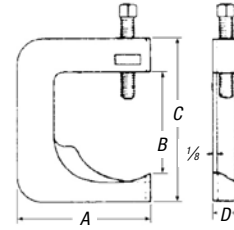

| CONDUIT SIZE | MAX. BEAM C-247 | FLANGE C-248 | THICKNESS C-249 |
|---------------|-----------------|--------------|-----------------|
| 1/2 | 5/8 | 1 | |
| 3/4 | 7/16 | 3/4 | 1 1/2 |
| 1 | | 1/2 | 1 1/4 |
| 1 1/4 | | 1 | |
| 1 1/2 | | | 5/8 |
| Dim. A | 2 1/4 | 2 9/16 | 3 3/4 |
| Dim. B | 1 3/8 | 1 3/4 | 2 1/2 |
| Dim. C | 2 3/4 | 3 | 4 |
| Dim. D | 9/16 | 5/16 | 5/8 |
| Per Carton | 100 | 50 | 50 |
| Wt. in lbs./C | 33 | 36 | 59 |

Standard Finish – GoldGalv®, unless otherwise stated.

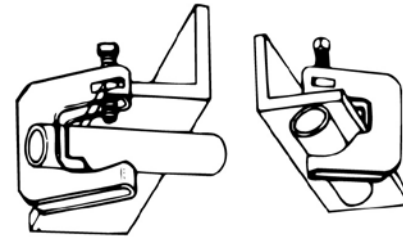

Pipe Supports

Three types of pipe clamps are available to provide right angle, vertical and parallel attachment to a beam. Types RC, EC and PC are malleable iron clamps with an edge that grips the structural member for maximum holding power when tightened.

Type RCS clamps are all steel, providing two bearing surfaces for strong attachment for mounting pipe or conduit at right angles to the beam.

All parts are electrogalvanized, including the threads. The clamps are designed for clamping to a wide variety of beam thicknesses and tapers. Can be installed using only a wrench.

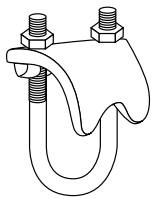

- RC Clamp — Malleable Iron
- RCS Clamp — Steel
- For mounting pipe or conduit at right angles to the beam
- Use SS316 suffix for 316 Stainless Steel
- Use HDG suffix for hot-dip galvanized

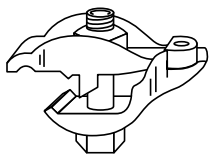

- EC Clamp — Malleable Iron
- For mounting pipe or conduit vertically across the beam
- Use SS316 suffix for 316 Stainless Steel
- Use HDG suffix for hot-dip galvanized

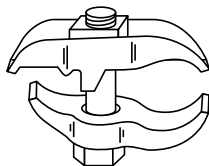

- PC Clamp — Malleable Iron
- For mounting pipe or conduit parallel to the beam
- Use SS316 suffix for 316 Stainless Steel
- Use HDG suffix for hot-dip galvanized

| CAT. NO. & SIZE | DIMENSIONS (IN.) | | | CAT. NO. & SIZE | DIMENSIONS (IN.) | | |
|-----------------|-------------------------|----------------|-----------|-----------------|-------------------------|----------------|-----------|
| | O.D. OF CONDUIT OR PIPE | NOM. PIPE SIZE | STD. CTN. | | O.D. OF CONDUIT OR PIPE | NOM. PIPE SIZE | STD. CTN. |
| RCS-1/2 | .840 | 1/2 | 50 | EC-1/2 | .840 | 1/2 | 50 |
| RCS-3/4 | 1.050 | 3/4 | 50 | EC-3/4 | 1.050 | 3/4 | 50 |
| RCS-1 | 1.315 | 1 | 50 | EC-1 | 1.315 | 1 | 25 |
| RCS-1-1/4 | 1.660 | 1 1/4 | 50 | EC-1-1/4 | 1.660 | 1 1/4 | 25 |
| RCS-1-1/2 | 1.900 | 1 1/2 | 50 | EC-1-1/2 | 1.900 | 1 1/2 | 25 |
| RCS-2 | 2.375 | 2 | 50 | EC-2 | 2.375 | 2 | 25 |
| RC-3/8 | .675 | 3/8 | 50 | EC-2-1/2 | 2.875 | 2 1/2 | 10 |
| RC-1/2 | .840 | 1/2 | 50 | EC-3 | 3.500 | 3 | 10 |
| RC-3/4 | 1.050 | 3/4 | 50 | PC-3/8 | .675 | 3/8 | 50 |
| RC-1 | 1.315 | 1 | 50 | PC 1/2 | .840 | 1/2 | 50 |
| RC-1-1/4 | 1.660 | 1 1/4 | 50 | PC-3/4 | 1.050 | 3/4 | 50 |
| RC-1-1/2 | 1.900 | 1 1/2 | 50 | PC-1 | 1.315 | 1 | 50 |
| RC-2-SC | 2.375 | 2 | 50 | PC-1-1/4 | 1.660 | 1 1/4 | 25 |
| RC-2-1/2 | 2.875 | 2 1/2 | 25 | PC-1-1/2 | 1.900 | 1 1/2 | 25 |
| RC-3 | 3.500 | 3 | 25 | PC-2 | 2.375 | 2 | 25 |
| RC-3-1/2 | 4.000 | 3 1/2 | 25 | PC-2-1/2 | 2.875 | 2 1/2 | 25 |
| RC-4-SC | 4.500 | 4 | 20 | PC-3 | 3.500 | 3 | 10 |
| | | | | PC-3-1/2 | 4.000 | 3 1/2 | 10 |
| | | | | PC-4 | 4.500 | 4 | 10 |

Pipe Straps, Conduit Clamps and Hangers

Excellent Corrosion Resistance and a Superior Paint Base

GoldGalv® hardware finish is standard for all Superstrut® products. This is a multi-process finish of electro-plated zinc, followed by gold-colored trivalent chromium to give excellent corrosion resistance and a superior paint base. See **pages B-106–B-107** for a complete description of the GoldGalv® hardware finish. GoldGalv® hardware will be furnished if no other finish is specified.

Materials

Most products are manufactured from hot-rolled carbon steel bars or hot-rolled strip steel. Pipe rollers are cast iron. Products which are copper plated carry the letter "T" in the prefix.

Design Loads

Where design loads are indicated, they provide for a safety factor of 3 in conformance with the "AMERICAN STANDARD CODE FOR PRESSURE PIPING."

Hanger Design

Pipe hangers are of advanced design and afford a new and better way of ordinary use.

Standard Dimensions

The following, except where noted, apply to all beam clamp fittings.

Hole Size: 3/16" diameter

Material: 1 5/8" wide

Material: 1/4" thick

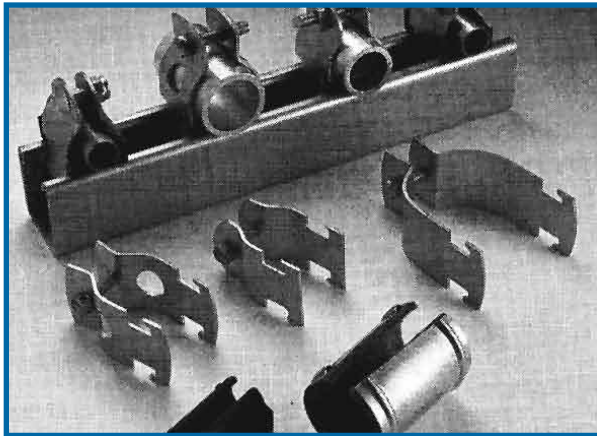
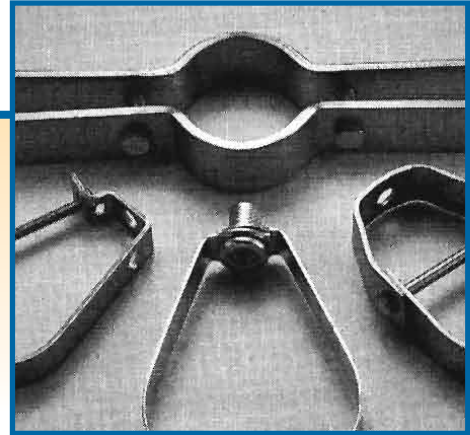

GoldGalv® Outperforms Copper Plated

In a test conforming to ASTM G-87-84, also known as the Kesternich Test, Superstrut's GoldGalv® electrogalvanized zinc trivalent chromium finish achieved superior corrosion resistance in comparison to copper plated.

Performed and certified by an independent testing laboratory, the stringent Kesternich test is equivalent to an acid rain environment. The test procedure exposes subject material to condensed moisture containing harsh sulfur dioxide (SO2) which accelerates the aging process. During the series of test time cycles, the material is thoroughly inspected for signs and progression of damaging red rust.

The first test series conducted included various light-duty adjustable clevis hangers assembled to copper tubing. The GoldGalv® finish exhibited five times the red rust resistance as compared to copper plated.

The second test series was performed on various O.D. pipe straps attached to copper tubing and continuous slot channel. GoldGalv® achieved greater red rust resistance by seven times over copper plating.

Once tests were completed, all copper tubes were split open and inspected for signs of electrolysis. The copper tubes showed minimal deterioration as a result of the test and no indication of electrolysis occurrence when attached to material with GoldGalv® finish.

ASTM G-87-84 Corrosion Test Results

| FINISH | INITIAL RED RUST | 50% RED RUST | 100% RED RUST |
|---|------------------|--------------|-----------------|
| Test Series I: Light-Duty Adjustable Clevis Hanger | | | |
| GoldGalv® | 120 hours | 216 hours | *Never obtained |
| Copper Plated | 24 hours | 48 hours | 72 hours |
| Test Series II: O.D. Pipe Straps | | | |
| GoldGalv® | 168 hours | 192 hours | 240 hours |
| Copper plated | 24 hours | 48 hours | 168 hours |

*Test series ended after 360 hours.

Standard Finish – GoldGalv®, unless otherwise stated.

Pipe Straps, Conduit Clamps and Hangers

The new standard for heavy-duty applications.

LOC-KING™ Cobra® One-Piece Cable and Pipe Clamp

The LOC-KING™ Cobra® heavy-duty pipe and cable clamp adds two new design innovations to the heavy-duty features of the original King Cobra® clamp.

First, a pre-set torque mechanism takes the guesswork out of installation, ensuring optimum torque and eliminating excess pressure on cables. Since the torque is pre-set, LOC-KING™ Cobra® clamps are ideally suited for use with power tools, making installation faster and more efficient than ever.

Second, the incorporation of an anti-vibration nut means that once installed, LOC-KING™ Cobra® clamps remain securely installed, even in high-vibration environments.

- Designed to be used on tray cable, Teck cable, metal-clad cable and armored cable
- Power-tool compatible for fast and efficient installation
- Pre-set torque mechanism takes the guesswork out of installation, delivering optimum torque even when using power tools
- Pre-set torque prevents over-tightening and excess pressure
- Anti-vibration nut ensures permanent installation, even in high-vibration environments
- Superior design load capabilities for heavy-duty applications: 350 lbs. for ½"-2½" trade sizes; 450 lbs. for 3"-4" trade sizes

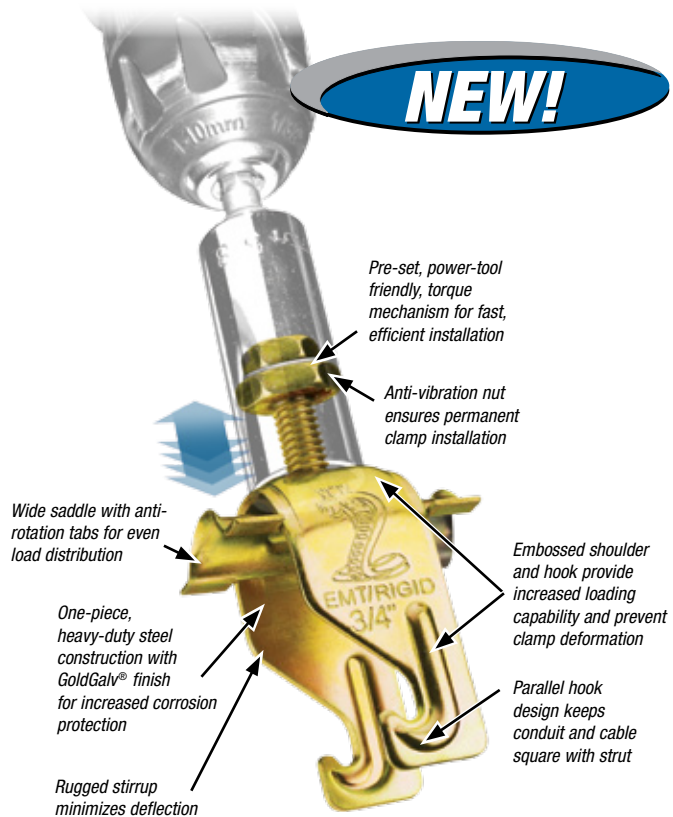

1 Position LOC-KING™ Cobra® clamp.



2 Using a power tool fitted with a ¼" (16mm) socket, tighten lock nut...



3 ...until it "blocks" and will no longer turn. Installation is complete.

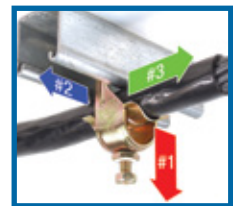

See Ratings in the Table Below

Note: When pre-set torque engages, lock-nut separates from bolt head and stops firmly against clamp body.

| CAT. NO. | FOR EMT AND RIGID CONDUIT TRADE SIZES | CABLE O.D. RANGE (IN.) | ARROW #1 LOAD RATING* | ARROW #2 SLIP RATING** | ARROW #3 PULL RATING** | QUANTITY PER BOX |
|----------|---------------------------------------|------------------------|--------------------------|---------------------------|---------------------------|------------------|
| LKCPC050 | ½ | .650-.890 | 350 lbs. | 50 lbs. | 50 lbs. | 100 |
| LKCPC075 | ¾ | .860-1.110 | 350 lbs. | 50 lbs. | 50 lbs. | 100 |
| LKCPC100 | 1 | 1.100-1.400 | 350 lbs. | 50 lbs. | 50 lbs. | 100 |
| LKCPC125 | 1¼ | 1.400-1.725 | 350 lbs. | 50 lbs. | 50 lbs. | 50 |
| LKCPC150 | 1½ | 1.690-1.980 | 350 lbs. | 50 lbs. | 50 lbs. | 50 |
| LKCPC200 | 2 | 1.980-2.576 | 350 lbs. | 50 lbs. | 50 lbs. | 50 |
| LKCPC250 | 2½ | 2.576-3.060 | 350 lbs. | 50 lbs. | 50 lbs. | 25 |
| LKCPC300 | 3 | 3.060-3.626 | 450 lbs. | 50 lbs. | 50 lbs. | 25 |
| LKCPC350 | 3½ | 3.626-4.126 | 450 lbs. | 50 lbs. | 50 lbs. | 25 |
| LKCPC400 | 4 | 4.126-4.626 | 450 lbs. | 50 lbs. | 50 lbs. | 25 |

* Safety Factor of 4

** Safety Factor of 1

Pipe Straps, Conduit Clamps and Hangers

The new specification standard for heavy-duty industrial applications.



King Cobra® Cable and Pipe Clamp with GoldGalv® Finish

- Superior design load capabilities for industrial applications: 350 lbs. for ½" to 2½" trade sizes; 450 lbs. for 3" to 4" trade sizes
- Durable one-piece heavy-duty steel construction — designed specifically for use in industrial applications
- Embossed shoulder and hooks increase loading capability and durability, preventing deformation of clamps
- Rugged stirrup provides increased strength for heavier loads, minimizing deflection
- Wider saddle design with anti-rotation tabs distributes load evenly over a larger surface area, preventing jacket damage
- Increased corrosion protection* — GoldGalv® (yellow zinc trivalent) finish stands up to harsh industrial applications
- Parallel hook design keeps conduit and cable square with strut
- Heavy-duty 5/16" hex bolt
- One clamp size works on equal trade sizes for both EMT and rigid conduit, simplifying clamp specification



Cobra® One-Piece Cable and Pipe Clamp

Takes a bite out of your installation time!

- One-piece heavy-duty construction ready to install right out of the box, no need to break apart and reassemble, no screws or bolts to drop
- Installs quickly and securely using one hand
- Universal bolt head accepts a range of tools
- Eliminates the guesswork from clamp selection — one catalog number attaches equal trade sizes of EMT and rigid conduit
- Parallel hook design keeps conduits and cable square with strut
- Reconfigure wiring without complete disassembly. Remove cables easily without disturbing neighboring clamps



* Compared to conventional electrogalvanization.

| CAT. NO. | FOR EMT AND RIGID CONDUIT TRADE SIZE (IN.) | CABLE O.D. RANGE (IN.) | STATIC LOAD LIMIT (LB) SAFETY FACTOR = 4 | STD. CTN. |
|-------------------------|--|------------------------|--|-----------|
| GoldGalv® Finish | | | | |
| KCPC050 | ½ | .650-.890 | 350 | 100 |
| KCPC075 | ¾ | .860-1.110 | 350 | 100 |
| KCPC100 | 1 | 1.100-1.400 | 350 | 100 |
| KCPC125 | 1¼ | 1.400-1.725 | 350 | 50 |
| KCPC150 | 1½ | 1.690-1.980 | 350 | 50 |
| KCPC200 | 2 | 1.980-2.576 | 350 | 50 |
| KCPC250 | 2½ | 2.576-3.060 | 350 | 25 |
| KCPC300 | 3 | 3.060-3.626 | 450 | 25 |
| KCPC350 | 3½ | 3.626-4.126 | 450 | 25 |
| KCPC400 | 4 | 4.126-4.626 | 450 | 25 |

Standard Finish — GoldGalv®

| CAT. NO. | FOR EMT AND RIGID CONDUIT TRADE SIZE (IN.) | CABLE O.D. RANGE (IN.) | STATIC LOAD LIMIT (LB) SAFETY FACTOR = 4 | STD. CTN. |
|-------------------------|--|------------------------|--|-----------|
| EG Silver Finish | | | | |
| CPC025 | ¼ | .312-.600 | 200 | 100 |
| CPC050 | ½ | .650-.890 | 200 | 100 |
| CPC075 | ¾ | .860-1.110 | 200 | 100 |
| CPC100 | 1 | 1.100-1.400 | 200 | 100 |
| CPC125 | 1¼ | 1.400-1.725 | 200 | 50 |
| CPC150 | 1½ | 1.690-1.980 | 200 | 50 |
| CPC200 | 2 | 1.980-2.576 | 200 | 50 |
| CPC250 | 2½ | 2.576-3.060 | 350 | 25 |
| CPC300 | 3 | 3.060-3.626 | 350 | 25 |
| CPC350 | 3½ | 3.626-4.126 | 350 | 25 |
| CPC400 | 4 | 4.126-4.626 | 350 | 25 |

Stainless Steel: add suffix SS6.

Pipe Straps, Conduit Clamps and Hangers

Pre-assembled for easy handling and sorting.

Superstrut® Pipe Straps

Superstrut® Pipe Straps are designed to be twist inserted anywhere along the slot side of the channel. Pipes can be placed as closely as pipe couplings permit.

Some unique features of the straps include:

- Bolt head is combination slot and hex head for flexibility of attachment
- Square nut is captivated on the shoulder for easy one-handed tightening
- Straps are interchangeable with 1½" strut for broader application
- Straps are shipped assembled so counting and sorting are easier
- Pipe or conduit sizes are shown on the strap for easy identification
- All Superstrut® Straps are preassembled for easy handling and sorting

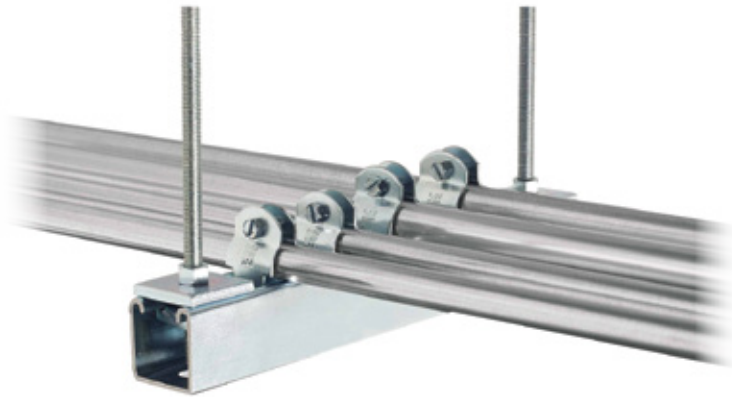

Design Loads

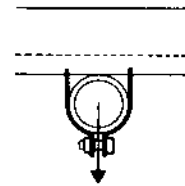

700 — Superstrut® Straps for EMT

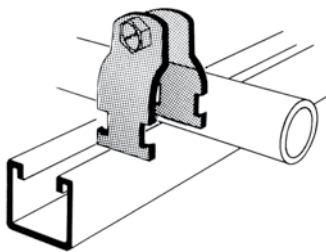

| CAT. NO. | EMT SIZE (IN.) | O.D. SIZE (IN.) | STEEL STRAP THICKNESS | DESIGN LOAD (LBS.) | STD. CTN. |
|---------------|----------------|-----------------|-----------------------|--------------------|-----------|
| 700 3/8-STR | 3/8 | .577 | 14 ga. | 750 | 100 |
| 700-1/2-STR | 1/2 | .706 | 14 ga. | 750 | 100 |
| 700-3/4-STR | 3/4 | .922 | 14 ga. | 750 | 100 |
| 700-1-STR | 1 | 1.163 | 14 ga. | 750 | 100 |
| 700-1-1/4-STR | 1 1/4 | 1.510 | 14 ga. | 750 | 50 |
| 700-1-1/2-STR | 1 1/2 | 1.740 | 12 ga. | 800 | 50 |
| 700-2-STR | 2 | 2.197 | 12 ga. | 800 | 50 |

Standard Finish — GoldGalv®

701 — Superstrut® Straps for O.D. Tubing



| CAT. NO. | TUBING O.D. (IN.) | STEEL STRAP THICKNESS | DESIGN LOAD (LBS.) | STD. CTN. |
|-------------|-------------------|-----------------------|--------------------|-----------|
| 701-1/4 | 1/4 | 14 ga. | 750 | 100 |
| 701-3/8 | 3/8 | 14 ga. | 750 | 100 |
| 701-1/2-STR | 1/2 | 14 ga. | 750 | 100 |
| 701-5/8 | 5/8 | 14 ga. | 750 | 100 |
| 701-3/4 | 3/4 | 14 ga. | 750 | 100 |
| 701-7/8 | 7/8 | 14 ga. | 750 | 100 |
| 701-1-STR | 1 | 14 ga. | 750 | 50 |
| 701-1-1/8 | 1 1/8 | 14 ga. | 1,000 | 100 |
| 701-1-1/4 | 1 1/4 | 14 ga. | 1,000 | 25 |
| 701-1-3/8 | 1 3/8 | 14 ga. | 1,000 | 100 |
| 701-1-1/2 | 1 1/2 | 14 ga. | 1,000 | 25 |
| 701-1-5/8 | 1 5/8 | 14 ga. | 1,000 | 100 |
| 701-1-3/4 | 1 3/4 | 12 ga. | 1,000 | 25 |
| 701-1-7/8 | 1 7/8 | 12 ga. | 1,000 | 50 |
| 701-2 | 2 | 12 ga. | 1,000 | 50 |
| 701-2-1/8 | 2 1/8 | 12 ga. | 1,300 | 50 |
| 701-2-1/4 | 2 1/4 | 12 ga. | 1,300 | 25 |
| 701-2-3/8 | 2 3/8 | 12 ga. | 1,300 | 25 |
| 701-2-1/2 | 2 1/2 | 12 ga. | 1,300 | 25 |
| 701-2-5/8 | 2 5/8 | 12 ga. | 1,300 | 50 |

(continued on following page)

Pipe Straps, Conduit Clamps and Hangers

701 — Superstrut® Straps for O.D. Tubing (continued)

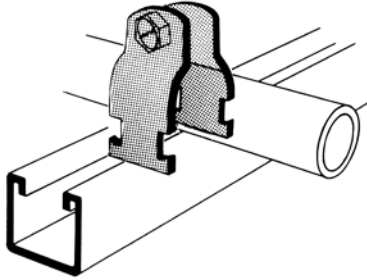

| CAT. NO. | TUBING O.D. (IN.) | STEEL STRAP THICKNESS | DESIGN LOAD (LBS.) | STD. CTN. |
|-----------|-------------------|-----------------------|--------------------|-----------|
| 701-2-3/4 | 2¾ | 12 ga. | 1,300 | 25 |
| 701-2-7/8 | 2¾ | 12 ga. | 1,300 | 25 |
| 701-3 | 3 | 12 ga. | 1,300 | 25 |
| 701-3-1/8 | 3¼ | 12 ga. | 1,300 | 25 |
| 701-3-1/4 | 3¼ | 12 ga. | 1,300 | 25 |
| 701-3-3/8 | 3¾ | 12 ga. | 1,300 | 25 |
| 701-3-1/2 | 3½ | 12 ga. | 1,300 | 25 |
| 701-3-5/8 | 3¾ | 11 ga. | 1,650 | 25 |
| 701-3-3/4 | 3¾ | 11 ga. | 1,650 | 25 |
| 701-3-7/8 | 3¾ | 11 ga. | 1,650 | 25 |
| 701-4 | 4 | 11 ga. | 1,650 | 25 |
| 701-4-1/8 | 4¼ | 11 ga. | 1,650 | 25 |
| 701-4-1/4 | 4¼ | 11 ga. | 1,650 | 25 |
| 701-4-3/8 | 4¾ | 11 ga. | 1,650 | 25 |
| 701-4-1/2 | 4½ | 11 ga. | 1,650 | 10 |
| 701-4-5/8 | 4¾ | 11 ga. | 1,650 | 10 |
| 701-4-3/4 | 4¾ | 11 ga. | 1,650 | 10 |
| 701-4-7/8 | 4¾ | 11 ga. | 1,650 | 10 |
| 701-5 | 5 | 11 ga. | 1,650 | 25 |
| 701-5-1/8 | 5¼ | 11 ga. | 1,650 | 10 |
| 701-5-1/4 | 5¼ | 11 ga. | 1,650 | 10 |
| 701-5-3/8 | 5¾ | 11 ga. | 1,650 | 10 |
| 701-5-1/2 | 5½ | 11 ga. | 1,650 | 10 |
| 701-5-5/8 | 5¾ | 10 ga. | 1,650 | 10 |
| 701-5-3/4 | 5¾ | 10 ga. | 1,650 | 10 |
| 701-5-7/8 | 5¾ | 10 ga. | 1,650 | 10 |
| 701-6 | 6 | 10 ga. | 1,650 | 10 |
| 701-6-1/8 | 6¼ | 10 ga. | 1,650 | 10 |
| 701-6-1/4 | 6¼ | 10 ga. | 1,650 | 10 |
| 701-6-3/8 | 6¾ | 10 ga. | 1,650 | 10 |
| 701-6-1/2 | 6½ | 10 ga. | 1,650 | 10 |
| 701-6-5/8 | 6¾ | 10 ga. | 1,650 | 10 |
| 701-6-3/4 | 6¾ | 10 ga. | 1,650 | 10 |
| 701-6-7/8 | 6¾ | 10 ga. | 1,650 | 10 |
| 701-8 | 8 | 10 ga. | 1,650 | 10 |

702 — Superstrut® Straps for Rigid Conduit, IMC and Pipe

- For Rigid or IMC Conduit, Pipe and Electric Metal Tubing (EMT)

| CAT. NO. | RIGID CONDUIT OR PIPE SIZE (IN.) | O.D. SIZE (IN.) | STEEL STRAP THICKNESS | DESIGN LOAD (LBS.) | STD. CTN. |
|-----------|----------------------------------|-----------------|-----------------------|--------------------|-----------|
| 702-3/8 | ¾ | .675 | 14 ga. | 750 | 100 |
| 702-1/2 | ½ | .840 | 14 ga. | 750 | 100 |
| 702-3/4 | ¾ | 1.050 | 14 ga. | 750 | 100 |
| 702-1 | 1 | 1.315 | 14 ga. | 750 | 100 |
| 702-1-1/4 | 1¼ | 1.660 | 14 ga. | 800 | 50 |
| 702-1-1/2 | 1½ | 1.900 | 12 ga. | 800 | 50 |
| 702-2-STR | 2 | 2.375 | 12 ga. | 800 | 50 |
| 702-2-1/2 | 2½ | 2.875 | 12 ga. | 1,000 | 50 |
| 702-3 | 3 | 3.500 | 12 ga. | 1,650 | 50 |
| 702-3-1/2 | 3½ | 4.000 | 11 ga. | 1,650 | 25 |
| 702-4 | 4 | 4.500 | 11 ga. | 1,650 | 25 |
| 702-4-1/2 | 4½ | 5.000 | 11 ga. | 1,650 | 25 |
| 702-5 | 5 | 5.563 | 11 ga. | 1,650 | 25 |
| 702-6 | 6 | 6.625 | 11 ga. | 1,650 | 10 |
| 702-8 | 8 | 8.625 | 11 ga. | 1,650 | 10 |
| 702-10 | 10 | 10.750 | 10 ga. | 1,650 | 25 |
| 702-12 | 12 | 12.750 | 10 ga. | 1,650 | 25 |

Standard Finish — GoldGalv® brand. For Electro-Galvanized (Silver), add EG suffix.

703 — Universal Clamp

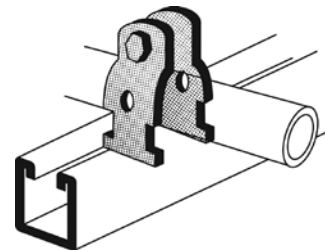

| CAT. NO. | PIPE O.D. (IN.) | STEEL STRAP THICKNESS | DESIGN LOAD (LBS.) | STD. CTN. |
|-----------|-----------------|-----------------------|--------------------|-----------|
| 703-1/2 | .706-.840 | 16 ga. | 400 | 100 |
| 703-3/4 | .932-1.050 | 14 ga. | 550 | 100 |
| 703 1 | 1.163-1.315 | 14 ga. | 550 | 100 |
| 703-1-1/4 | 1.508-1.660 | 14 ga. | 800 | 50 |
| 703-1-1/2 | 1.738-1.900 | 14 ga. | 800 | 50 |
| 703-2 | 2.195-2.375 | 14 ga. | 800 | 50 |

Standard Finish — GoldGalv®

Pipe Straps, Conduit Clamps and Hangers

Angled for easy tightening!

Angler® Pipe and Conduit Clamp



Metal Framing & Cable Tray — Superstrut® Metal Framing System

Universal Series — for EMT, IMC, Rigid and Standard Pipe



| CAT. NO. | SIZE (IN.) | STRAP THICKNESS | DESIGN LOAD (LBS.) | INSTALL TORQUE (IN. LBS.) | STD. CTN. |
|-------------------------|------------|-----------------|--------------------|---------------------------|-----------|
| GoldGalv® Finish | | | | | |
| C 109 1/2 | 1/2 | 14 ga. | 400 | 40 | 100 |
| C 109 3/4 | 3/4 | 14 ga. | 500 | 40 | 100 |
| C 109 1 | 1 | 14 ga. | 500 | 40 | 100 |
| C 109 1 1/4 | 1 1/4 | 14 ga. | 500 | 40 | 100 |
| C 109 1 1/2 | 1 1/2 | 12 ga. | 800 | 60 | 50 |
| C 109 2 | 2 | 12 ga. | 800 | 60 | 50 |
| C 109 2 1/2 | 2 1/2 | 12 ga. | 800 | 60 | 50 |
| C 109 3 | 3 | 12 ga. | 800 | 60 | 50 |
| C 109 3 1/2 | 3 1/2 | 11 ga. | 1,200 | 60 | 25 |
| C 109 4 | 4 | 11 ga. | 1,200 | 60 | 25 |

SilverGalv® Finish

| | | | | | |
|----------------|-------|--------|-------|----|-----|
| C 109 1/2 EG | 1/2 | 14 ga. | 400 | 40 | 100 |
| C 109 3/4 EG | 3/4 | 14 ga. | 500 | 40 | 100 |
| C 109 1 EG | 1 | 14 ga. | 500 | 40 | 100 |
| C 109 1 1/4 EG | 1 1/4 | 14 ga. | 500 | 40 | 100 |
| C 109 1 1/2 EG | 1 1/2 | 12 ga. | 800 | 60 | 50 |
| C 109 2 EG | 2 | 12 ga. | 800 | 60 | 50 |
| C 109 2 1/2 EG | 2 1/2 | 12 ga. | 800 | 60 | 50 |
| C 109 3 EG | 3 | 12 ga. | 800 | 60 | 50 |
| C 109 3 1/2 EG | 3 1/2 | 11 ga. | 1,200 | 60 | 25 |
| C 109 4 EG | 4 | 11 ga. | 1,200 | 60 | 25 |

Rigid Series — for Rigid Conduit and Standard Pipe



| CAT. NO. | SIZE (IN.) | STRAP THICKNESS | DESIGN LOAD (LBS.) | INSTALL TORQUE (IN. LBS.) | STD. CTN. |
|-------------------------|------------|-----------------|--------------------|---------------------------|-----------|
| GoldGalv® Finish | | | | | |
| C 109R 1/2 | 1/2 | 14 ga. | 600 | 40 | 100 |
| C 109R 3/4 | 3/4 | 14 ga. | 600 | 40 | 100 |
| C 109R 1 | 1 | 14 ga. | 600 | 40 | 100 |
| C 109R 1 1/4 | 1 1/4 | 14 ga. | 600 | 40 | 100 |
| C 109R 1 1/2 | 1 1/2 | 12 ga. | 800 | 60 | 50 |
| C 109R 2 | 2 | 12 ga. | 800 | 60 | 50 |
| C 109R 2 1/2 | 2 1/2 | 12 ga. | 800 | 60 | 50 |
| C 109R 3 | 3 | 12 ga. | 800 | 60 | 50 |
| C 109R 3 1/2 | 3 1/2 | 11 ga. | 1,200 | 60 | 25 |
| C 109R 4 | 4 | 11 ga. | 1,200 | 60 | 25 |

SilverGalv® Finish

| | | | | | |
|-----------------|-------|--------|-------|----|-----|
| C 109R 1/2 EG | 1/2 | 14 ga. | 600 | 40 | 100 |
| C 109R 3/4 EG | 3/4 | 14 ga. | 600 | 40 | 100 |
| C 109R 1 EG | 1 | 14 ga. | 600 | 40 | 100 |
| C 109R 1 1/4 EG | 1 1/4 | 14 ga. | 600 | 40 | 100 |
| C 109R 1 1/2 EG | 1 1/2 | 12 ga. | 800 | 60 | 50 |
| C 109R 2 EG | 2 | 12 ga. | 800 | 60 | 50 |
| C 109R 2 1/2 EG | 2 1/2 | 12 ga. | 800 | 60 | 50 |
| C 109R 3 EG | 3 | 12 ga. | 800 | 60 | 50 |
| C 109R 3 1/2 EG | 3 1/2 | 11 ga. | 1,200 | 60 | 25 |
| C 109R 4 EG | 4 | 11 ga. | 1,200 | 60 | 25 |

Hex head size 3/8" for 1/2" to 1 1/4" sizes, 1/2" for 1 1/2" to 4" sizes.

Material: Stamped Steel.

Pipe sizes 2 1/2" to 4" utilize the same clamps for the Rigid Series and the Universal Series.

Pipe Straps, Conduit Clamps and Hangers

A-716 — Snap•Guard® Cushioned Clamp Tube Series

P-716 — Pipe Series

- Assembly consisting of GoldGalv® finish steel clamp with bolt/locknut and cushion
- Secure pipes, tubes and hoses for fluid conductors
- Installation is easy and requires no more time than a simple pipe clamp installation
- Cushion absorbs the shocks and associated vibrations from fluid surges in tubes, pipes and hoses
- Can handle temperatures from -40° F to 300° F
- Cushioned Clamp assemblies are available individually bagged

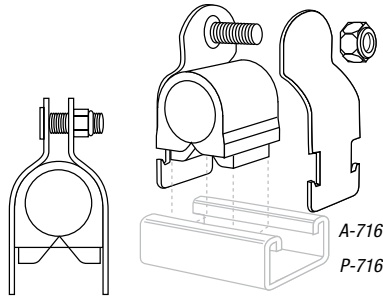

| O.D. TUBING SIZES | | STANDARD PIPE SIZES | | STD. CTN. |
|-------------------|-----------------|---------------------|-------------------------|-----------|
| ASSEMBLY CAT. NO. | TUBE O.D. (IN.) | ASSEMBLY CAT. NO. | NOMINAL PIPE SIZE (IN.) | |
| A-716-1/4 | ¼ | P-716-1/4 | ¼ | 25 |
| A-716-3/8 | ⅜ | P-716-3/8 | ⅜ | 25 |
| A-716-1/2 | ½ | P-716-1/2 | ½ | 25 |
| A-716-5/8 | ⅝ | P-716-3/4 | ¾ | 25 |
| A-716-3/4 | ¾ | P-716-1 | 1 | 25 |
| A-716-7/8 | ⅞ | P-716-1-1/4 | 1¼ | 25 |
| A-716-1 | 1 | P-716-1-1/2 | 1½ | 10 |
| A-716-1-1/8 | 1⅛ | P-716-2 | 2 | 10 |
| A-716-1-1/4 | 1¼ | P-716-2-1/2 | 2½ | 10 |
| A-716-1-3/8 | 1⅜ | P-716-3 | 3 | 10 |
| A-716-1-1/2 | 1½ | P-716-3-1/2 | 3½ | 10 |
| A-716-1-5/8 | 1⅝ | P-716-4 | 4 | 10 |
| A-716-1-3/4 | 1¾ | — | — | 10 |
| A-716-1-7/8 | 1⅞ | — | — | 10 |
| A-716-2 | 2 | — | — | 10 |
| A-716-2-1/8 | 2⅛ | — | — | 10 |
| A-716-2-3/8 | 2⅜ | — | — | 10 |
| A-716-2-5/8 | 2⅝ | — | — | 10 |
| A-716-3-1/8 | 3⅛ | — | — | 10 |
| A-716-4-1/8 | 4⅛ | — | — | 10 |

Standard Finishes — GoldGalv® brand. Available in Stainless Steel — use SS suffix. (i.e) A-716-1SS, Electro-Galvanized (Silver) — use EG suffix. (i.e) A-716-1EG

U-716, U-717 — Two-Hole Cushioned Clamp

- Guides, protects and uniformly spaces line runs. Low-cost, time-saving method of attaching tubing and hose to equipment
- Cushion is built to withstand the effects of most oils, chemical and industrial cleaning compounds, in temperatures from -50° F to 275° F. Interlock edge ensures cushion remains in place
- Clamp available in steel with the GoldGalv® hardware finish
- Attached with two standard fasteners to any flat surface, this clamp eliminates the use of special channels, providing a savings in both space requirements and cost
- Cushioned clamps reduce vibration, shock and noise in fluid systems and eliminate electrolysis

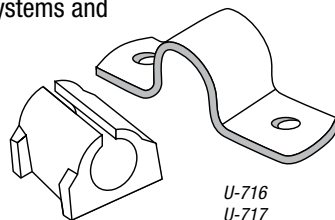

| ASSEMBLY CAT. NO. | COPPER AND STEEL TUBING O.D. (IN.) | COPPER WATER PIPE (NOM.) (IN.) | NOMINAL PIPE SIZE (IN.) | STD. CTN. |
|-------------------|------------------------------------|--------------------------------|-------------------------|-----------|
| U716 1/4 | ¼ | — | — | 25 |
| U-716-3/8 | ⅜ | ¼ | — | 25 |
| U-716-1/2 | ½ | ⅜ | ¼ | 25 |
| U-716-5/8 | ⅝ | ½ | ⅜ | 25 |
| U-716-3/4 | ¾ | ⅝ | — | 25 |
| U-716-7/8 | ⅞ | ¾ | ½ | 25 |
| U-716-1 | 1 | — | — | 25 |
| U-716-1-1/8 | 1⅛ | 1 | — | 25 |
| U-716-1-1/4 | 1¼ | — | — | 10 |
| U-716-1-3/8 | 1⅜ | 1¼ | — | 10 |
| U-716-1-1/2 | 1½ | — | — | 10 |
| U-716-1-5/8 | 1⅝ | 1½ | — | 10 |
| U-716-1-3/4 | 1¾ | — | — | 10 |
| U-716-1-7/8 | 1⅞ | — | 1½ | 10 |
| U-716-2 | 2 | — | — | 10 |
| U-716-2-1/8 | 2⅛ | — | — | 10 |
| U-716-2-3/8 | 2⅜ | — | — | 10 |
| U-717-3/4 | — | — | ¾ | 25 |
| U-717-1 | — | — | 1 | 10 |
| U-717-1-1/4 | — | — | 1¼ | 10 |

Standard Finish — GoldGalv®

Pipe Straps, Conduit Clamps and Hangers

C-716 — Isolator for Copper Tubing

Features:

Designed for use with Superstrut® channel and pipe straps and Superstrut® C-711 Hangers, and may also be used with all standard flatbar or malleable iron hangers.

Materials:

Manufactured from one-piece steel shell with reinforcing ribs for stiffening and alignment. Padding is of processed non-conducting hairfelt and is cemented to the metal. Design of ribs creates a hinge so isolator may be opened and closed to install.

Application:

To provide a means to effectively isolate copper tubing from its supports to prevent the transmission of sound and vibration.

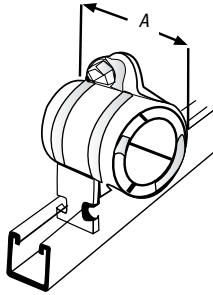

| CAT. NO. | SIZE (IN.) | NOMINAL PIPE SIZE (IN.) | HANGER, C-711 OR PIPE STRAP, 702 | WIDTH A (IN.) | STD. CTN. |
|-------------|------------|-------------------------|----------------------------------|---------------|-----------|
| C716 1/2 | 1/2 | 1/2 | 3/4 | 2 5/8 | 100 |
| C-716-3/4 | 3/4 | 3/4 | 3/4 | 2 5/8 | 100 |
| C-716-1 | 1 | 1 | 1 | 2 5/8 | 100 |
| C-716-1-1/4 | 1 1/4 | 1 1/4 | 1 1/4 | 2 5/8 | 50 |
| C-716-1-1/2 | 1 1/2 | 1 1/2 | 1 1/2 | 2 5/8 | 50 |
| C-716-2 | 2 | 2 | 2 1/2 | 2 5/8 | 50 |
| C-716-2-1/2 | 2 1/2 | 2 1/2 | 3 | 2 15/32 | 50 |
| C-716-3 | 3 | 3 | 3 1/2 | 2 5/8 | 50 |
| C-716-3-1/2 | 3 1/2 | 3 1/2 | 4 | 4 1/4 | 30 |
| C-716-4 | 4 | 4 | 5 | 4 1/4 | 20 |

Order by Cat. No. and size.
Standard Finish — GoldGalv®

S716 — Cushioned Strip — For Isolation and Vibration Applications

For use with 701 O.D. tubing and pipe clamp. To determine 701 clamp size, add 1/4" to O.D. tube size to allow for the cushioned strip material.

1/4" markings for fast measuring and cutting. Measurement chart is printed on back of carton. 20 feet included in each carton.

Prevent metal-to-metal contact with the cushioned strip material. It aids in sound insulation, shock absorption and protects against corrosion, distortion and abrasion. Cushioned strip material is designed for optimal use between -30° F and 300° F. Cushioned strip material combined with the Superstrut® 701 pipe strap can handle clamping assignments from 1/4" to 6.

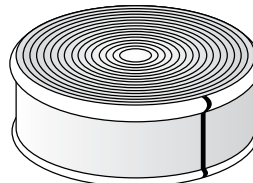

S716

Sold in a carton of 20 feet.

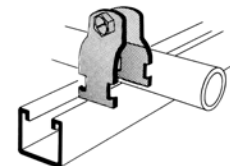

Order 701 clamp separately.

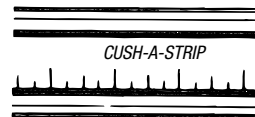

CUSH-A-STRIP



1/4"

C-708-U — Short Strap for Channel or Wall Mounting

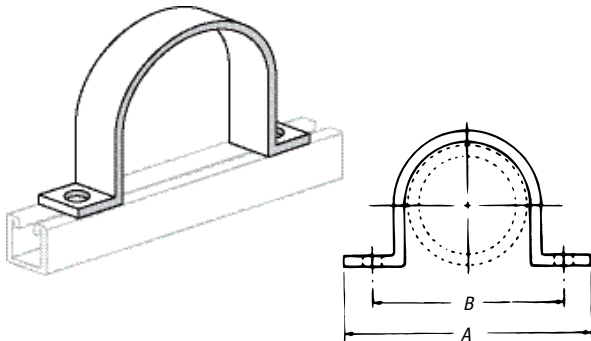

| CAT. NO. | PIPE SIZE | DIMENSIONS (IN.) | | HOLE SIZE | STOCK SIZE | DESIGN LOAD LBS. | STD. CTN. |
|---------------|-----------|------------------|---------|-----------|---------------|------------------|-----------|
| | | A | B | | | | |
| C-708-U-1/2 | 1/2 | 2 1/8 | 2 | 5/32 | 1/8 x 1 1/8 | 650 | 50 |
| C-708-U-3/4 | 3/4 | 3 1/16 | 2 3/16 | 5/32 | 1/8 x 1 1/8 | 650 | 50 |
| C-708-U-1 | 1 | 3 3/8 | 2 1/2 | 5/32 | 1/8 x 1 1/8 | 650 | 50 |
| C-708-U-1-1/4 | 1 1/4 | 3 11/16 | 2 3/16 | 5/32 | 1/8 x 1 1/8 | 650 | 25 |
| C-708-U-1-1/2 | 1 1/2 | 3 15/16 | 3 1/16 | 5/32 | 1/8 x 1 1/8 | 650 | 25 |
| C-708-U-2 | 2 | 5 3/4 | 4 1/8 | 7/16 | 1/4 x 1 5/8 | 650 | 25 |
| C-708-U-2-1/2 | 2 1/2 | 6 3/16 | 4 9/16 | 7/16 | 1/4 x 1 5/8 | 1,000 | 25 |
| C-708-U-3 | 3 | 6 3/16 | 5 3/16 | 7/16 | 1/4 x 1 5/8 | 1,000 | 25 |
| C-708-U-3-1/2 | 3 1/2 | 7 7/16 | 5 11/16 | 7/16 | 1/4 x 1 15/32 | 1,000 | 25 |
| C-708-U-4 | 4 | 7 13/16 | 6 3/16 | 7/16 | 1/4 x 1 15/32 | 1,200 | 25 |
| C-708-U-5 | 5 | 8 7/8 | 7 1/4 | 7/16 | 1/4 x 1 15/32 | 1,200 | 10 |
| C-708-U-6 | 6 | 9 15/16 | 8 3/16 | 7/16 | 1/4 x 1 15/32 | 1,200 | 10 |

Carbon Steel.
Standard Finish — GoldGalv®

Pipe Straps, Conduit Clamps and Hangers

CB118 — Counter Bed

| CAT. NO. | STD. CTN. |
|--------------------|-----------|
| <i>Counter Bed</i> | |
| CB118-047PG | 100 |
| CB118-055PG | 100 |
| CB118-070PG | 100 |
| CB118-090PG | 100 |
| CB118-110PG | 100 |

| CAT. NO. | STD. CTN. |
|--------------------|-----------|
| <i>Counter Bed</i> | |
| CB118-140PG | 100 |
| CB118-175PG | 100 |
| CB118-200PG | 100 |
| CB118-250PG | 100 |
| CB118-300PG | 100 |

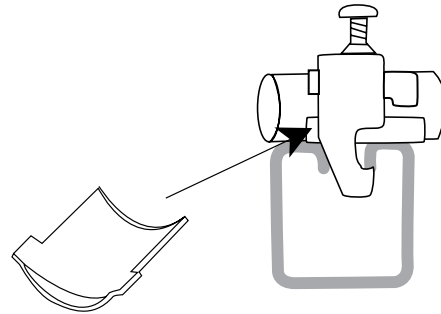

CB118
Counter Bed

EB118 — Extended Bed

| CAT. NO. | STD. CTN. |
|---------------------|-----------|
| <i>Extended Bed</i> | |
| EB118-047PG | 100 |
| EB118-055PG | 100 |
| EB118-070PG | 100 |
| EB118-090PG | 100 |
| EB118-110PG | 100 |

| CAT. NO. | STD. CTN. |
|---------------------|-----------|
| <i>Extended Bed</i> | |
| EB118-140PG | 100 |
| EB118-175PG | 1 |
| EB118-200PG | 1 |
| EB118-250PG | 1 |
| EB118-300PG | 1 |

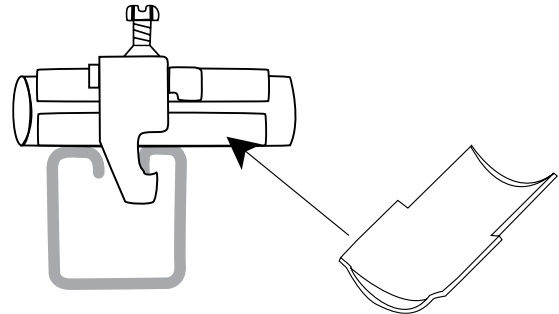

EB118
Extended Bed

DB118 — Double Bed

| CAT. NO. | STD. CTN. |
|-------------------|-----------|
| <i>Double Bed</i> | |
| DB118-047PG | 1 |
| DB118-055PG | 1 |

| CAT. NO. | STD. CTN. |
|-------------------|-----------|
| <i>Double Bed</i> | |
| DB118-070PG | 1 |
| DB118-090PG | 1 |

Note: Not sold in pairs.

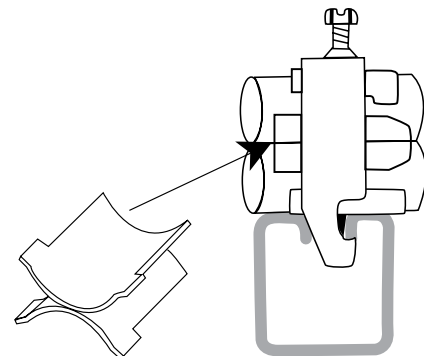

DB118
Double Bed

Pipe Straps, Conduit Clamps and Hangers

C-755 — Porcelain Cable Clamps

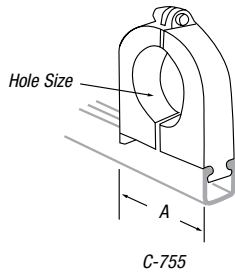

| CAT. NO. | HOLE SIZE (IN.) | A (IN.) | STD. CTN. |
|----------|-----------------|---------|-----------|
| C-755-1A | 3/8 | 1 1/16 | 10 |
| C-755-1B | 1/2 | 1 1/16 | 10 |
| C-755-1C | 5/8 | 1 1/16 | 10 |
| C-755-2 | 3/4 | 2 5/32 | 10 |
| C-755-2A | 7/8 | 2 5/32 | 10 |
| C-755-2B | 1 | 2 5/32 | 10 |
| C-755-2C | 1 1/8 | 2 5/32 | 10 |
| C-755-3 | 1 1/4 | 2 5/8 | 10 |
| C-755-3A | 1 3/8 | 2 5/8 | 10 |
| C-755-3B | 1 1/2 | 2 5/8 | 10 |
| C-755-3C | 1 5/8 | 2 5/8 | 10 |
| C-755-4 | 1 3/4 | 3 3/8 | 10 |
| C-755-4A | 1 7/8 | 3 3/8 | 10 |
| C-755-4B | 2 | 3 3/8 | 10 |
| C-755-4C | 2 1/8 | 3 3/8 | 10 |
| C-755-5 | 2 1/4 | 4 1/4 | 10 |
| C-755-5A | 2 3/8 | 4 1/4 | 10 |
| C-755-5B | 2 1/2 | 4 1/4 | 10 |
| C-755-5C | 2 5/8 | 4 1/4 | 10 |
| C-755-6 | 2 5/8 | 4 3/8 | 10 |
| C-755-6A | 2 7/8 | 4 3/8 | 10 |
| C-755-6B | 3 | 4 3/8 | 10 |
| C-755-6C | 3 1/8 | 4 3/8 | 10 |
| C-755-7 | 3 1/4 | 5 1/16 | 10 |
| C-755-7A | 3 3/8 | 5 1/16 | 10 |
| C-755-7B | 3 1/2 | 5 1/16 | 10 |
| C-755-7C | 3 5/8 | 5 1/16 | 10 |
| C-755-8 | 3 3/4 | 6 3/8 | 5 |
| C-755-8A | 3 7/8 | 6 3/8 | 5 |
| C-755-8B | 4 | 6 3/8 | 5 |
| C-755-8C | 4 1/8 | 6 3/8 | 5 |
| C-755-8D | 4 1/4 | 6 3/8 | 5 |
| C-755-8E | 4 3/8 | 6 3/8 | 5 |
| C-755-8F | 4 1/2 | 6 3/8 | 5 |

Finish – GoldGalv® brand with bronze hardware.

Also fits 1 1/2" wide channel.

C-755 — TPE Cable Clamps

An easy-to-use one-piece insulator made from Sarlink 4339D, a flame-retardant, high hardness grade TPE polymer that is UL Listed. The tapered flange of the insulator ensures complete isolation and protection of the cable. Options include a Stainless Steel Clamp and hardware or an Electro-Galvanized Clamp with Everdur nut and bolt.



- Non-breakable TPE material
- Exceptional chemical resistance
- Dielectric strength of 640 volts per mil
- Stainless Steel Clamps Type 304 or 316
- Electro-Galvanized Steel Clamps with Everdur Nut and Bolt
- Flame-retardant TPE insulator
- Excellent UV resistance

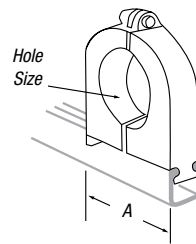

| CAT. NO. | HOLE SIZE (IN.) | A (IN.) | CAT. NO. | HOLE SIZE (IN.) | A (IN.) |
|-------------|-----------------|---------|-------------|-----------------|---------|
| C755 1ATP | 3/8 | 1.36 | C-755-5B-TP | 2 1/2 | 3.36 |
| C-755-1B-TP | 1/2 | 1.36 | C-755-5C-TP | 2 5/8 | 3.36 |
| C-755-1C-TP | 5/8 | 1.36 | C-755-6-TP | 2 3/4 | 3.86 |
| C-755-2-TP | 3/4 | 1.86 | C-755-6A-TP | 2 7/8 | 3.86 |
| C-755-2A-TP | 7/8 | 1.86 | C-755-6B-TP | 3 | 3.86 |
| C-755-2B-TP | 1 | 1.86 | C-755-6C-TP | 3 1/8 | 3.86 |
| C-755-2C-TP | 1 1/8 | 1.86 | C-755-7-TP | 3 1/4 | 4.36 |
| C-755-3-TP | 1 1/4 | 2.36 | C-755-7A-TP | 3 3/8 | 4.36 |
| C-755-3A-TP | 1 3/8 | 2.36 | C-755-7B-TP | 3 1/2 | 4.36 |
| C-755-3B-TP | 1 1/2 | 2.36 | C-755-7C-TP | 3 5/8 | 4.36 |
| C-755-3C-TP | 1 5/8 | 2.36 | C-755-8-TP | 3 3/4 | 4.86 |
| C-755-4-TP | 1 3/4 | 2.86 | C-755-8A-TP | 3 7/8 | 4.86 |
| C-755-4A-TP | 1 7/8 | 2.86 | C-755-8B-TP | 4 | 4.86 |
| C-755-4B-TP | 2 | 2.86 | C-755-8C-TP | 4 1/8 | 4.86 |
| C-755-4C-TP | 2 1/8 | 2.86 | C-755-8D-TP | 4 1/4 | 5.24 |
| C-755-5-TP | 2 1/4 | 3.36 | C-755-8E-TP | 4 3/8 | 5.24 |
| C-755-5A-TP | 2 3/8 | 3.36 | C-755-8F-TP | 4 1/2 | 5.24 |

Pipe Straps, Conduit Clamps and Hangers

HS Series Two-Hole Pipe Strap



| CAT. NO. | PIPE SIZE (IN.) | STD. CTN. |
|----------|-----------------|-----------|
| HS901 | ½ | 500 |
| HS902 | ¾ | 500 |
| HS903 | 1 | 500 |
| HS904 | 1¼ | 250 |
| HS905 | 1½ | 250 |
| HS906 | 2 | 125 |
| HS907 | 2½ | 125 |
| HS908 | 3 | 100 |
| HS909 | 3½ | 75 |
| HS910 | 4 | 50 |

Standard Finish — Galvanized.
Carbon steel.
Specify pipe size and catalog number.
For stainless steel, add suffix SS.

HS Series One-Hole Pipe Straps



| CAT. NO. | PIPE SIZE (IN.) | STD. CTN. |
|----------|-----------------|-----------|
| HS100 | ¾ | 500 |
| HS101 | ½ | 500 |
| HS102 | ¾ | 500 |
| HS103 | 1 | 500 |
| HS104 | 1¼ | 250 |
| HS105 | 1½ | 250 |
| HS106 | 2 | 50 |
| HS107 | 2½ | 25 |
| HS108 | 3 | 25 |
| HS109 | 3½ | 25 |
| HS110 | 4 | 25 |

For stainless steel, add suffix SS.

C-720, C-720SS — Extension Riser Clamp

Designed for the support or steadying of vertical pipe risers. It is made of carbon steel and is designed to hold tight to the pipe, transmitting the load to the structure through the ears on each end. When possible, the clamp should be placed under a coupling, hub or lugs welded to the pipe.

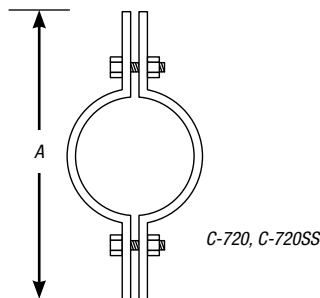

C-720, C-720SS

Specifications

- Material: Carbon Steel
- Compliance: Federal Specification A-A-1192A Type 8, MSS-SP-69 (Type 8) and BSPSS-BS3974.
- Finish: Standard Finish – GoldGalv®, Black (add suffix “-B”), Electro-Galvanized (add suffix “-EG”).

Note: This product is not designed to be supported with rods. Install using the maximum suggested torque values shown in the Technical Section of this catalog.

| CAT. NO. | PIPE SIZE (IN.) | MAX. LOAD (LBS.) | A (IN.) | WT. EACH |
|-------------|-----------------|------------------|---------|----------|
| C-720-1/2 | ½ | 255 | 9 | 1.00 |
| C-720-3/4 | ¾ | 255 | 8½ | 1.08 |
| C-720-1 | 1 | 255 | 8½ | 1.08 |
| C-720-1-1/4 | 1¼ | 255 | 10 | 1.86 |
| C-720-1-1/2 | 1½ | 255 | 10¼ | 1.22 |
| C-720-2 | 2 | 255 | 10¼ | 1.30 |
| C-720-2-1/2 | 2½ | 390 | 11¼ | 1.74 |
| C-720-3 | 3 | 530 | 11½ | 1.98 |
| C-720-3-1/2 | 3½ | 670 | 12½ | 2.14 |
| C-720-4 | 4 | 810 | 12½ | 2.28 |
| C-720-5 | 5 | 1,160 | 13¾ | 3.60 |
| C-720-6 | 6 | 1,570 | 14¾ | 3.68 |
| C-720-8 | 8 | 2,500 | 18½ | 7.26 |
| C720 10 | 10 | 2,500 | 20¾ | 11.00 |
| C-720-12 | 12 | 2,700 | 22¾ | 15.94 |
| C-720-14 | 14 | 2,700 | 24 | 17.36 |
| C-720-16 | 16 | 2,900 | 26 | 29.68 |
| C-720-18 | 18 | 2,900 | 28 | 31.64 |
| C-720-20 | 20 | 2,900 | 30 | 34.84 |
| C-720-24 | 24 | 2,900 | 34 | 50.00 |

Standard Finish – GoldGalv®, unless otherwise stated.

Pipe Straps, Conduit Clamps and Hangers

C-720L — Offset Pipe Clamp

The Offset Pipe Clamp is used on pipe lines running at a fixed distance from a wall or floor. The standard clearance is two inches from the O.D. of pipe to the face of the surface. Non-standard clearances can be fabricated upon request.

Specifications

- Material: Carbon Steel
- Load Rating: Up to 650° F (343° C)
- Finish: Standard Finish – GoldGalv®, Black (add suffix “-B”), Electro-Galvanized (add suffix “-EG”)
- Ordering: Specify pipe size, catalog number and finish

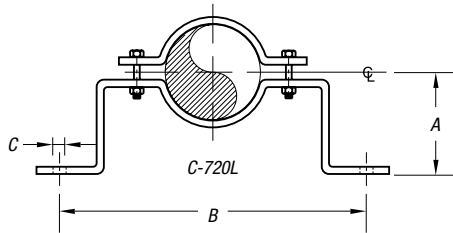

| CAT. NO. | PIPE SIZE (IN.) | MAX. LOAD (LBS.) | A (IN.) | B (IN.) | C (IN.) | WT. EACH (LBS.) |
|--------------|-----------------|------------------|---------|---------|---------|-----------------|
| C-720L-1/2 | 1/2 | 190 | 2 1/16 | 8 1/2 | 7/16 | 1.1 |
| C-720L-3/4 | 3/4 | 190 | 2 3/4 | 8 3/4 | 7/16 | 1.3 |
| C-720L-1 | 1 | 190 | 2 7/8 | 9 1/4 | 7/16 | 1.4 |
| C-720L-1-1/4 | 1 1/4 | 190 | 3 1/16 | 9 3/4 | 7/16 | 1.5 |
| C-720L-1-1/2 | 1 1/2 | 190 | 3 3/16 | 10 | 7/16 | 1.6 |
| C-720L-2 | 2 | 420 | 3 1/2 | 11 1/4 | 9/16 | 2.8 |
| C-720L-2-1/2 | 2 1/2 | 420 | 3 3/4 | 11 3/4 | 9/16 | 2.9 |
| C-720L-3 | 3 | 420 | 4 1/16 | 12 7/8 | 9/16 | 3.2 |
| C-720L-4 | 4 | 610 | 4 9/16 | 13 7/8 | 9/16 | 4.2 |
| C-720L-5 | 5 | 610 | 5 1/16 | 15 5/8 | 1 1/16 | 6.5 |
| C-720L-6 | 6 | 870 | 5 3/4 | 16 3/4 | 1 1/16 | 7.2 |
| C-720L-8 | 8 | 870 | 6 3/8 | 18 3/4 | 1 1/16 | 8.3 |
| C-720L-10 | 10 | 1,050 | 7 1/8 | 21 1/2 | 1 3/16 | 12.4 |
| C-720L-12 | 12 | 1,200 | 8 3/8 | 24 7/8 | 1 3/16 | 21.0 |

Standard Finish – GoldGalv®, unless otherwise stated.

CX-725 — Extended Offset Pipe Clamp

Designed to attach directly to piping where the exact distance between the structure and the pipe cannot be determined until the piping is in place. The extended legs can be modified in the field to suit the location. Legs of longer lengths can be furnished on order.

Specifications

- Material: Carbon Steel
- Finish: Standard Finish – Black (add suffix “-B”), Electro-Galvanized (add suffix “-EG”)
- Ordering: Specify pipe size, catalog number and finish

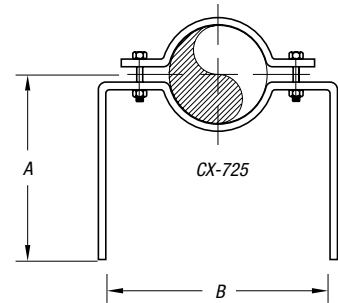

| CAT. NO. | PIPE SIZE (IN.) | A (IN.) | B (IN.) | WT. EACH (LBS.) |
|--------------|-----------------|---------|---------|-----------------|
| CX-725-3/8 | 3/8 | 12 | 3 3/4 | 1.85 |
| CX-725-1/2 | 1/2 | 12 | 3 3/4 | 1.85 |
| CX-725-3/4 | 3/4 | 12 | 4 3/4 | 1.85 |
| CX-725-1 | 1 | 12 | 5 1/2 | 2.34 |
| CX-725-1-1/4 | 1 1/4 | 12 | 5 5/8 | 2.40 |
| CX-725-1-1/2 | 1 1/2 | 12 | 6 1/8 | 2.45 |
| CX-725-2 | 2 | 12 | 7 | 3.13 |
| CX-725-2-1/2 | 2 1/2 | 12 | 7 1/2 | 4.21 |
| CX-725-3 | 3 | 12 | 7 7/8 | 4.47 |
| CX-725-4 | 4 | 12 | 10 1/2 | 4.90 |
| CX-725-5 | 5 | 12 | 12 1/4 | 4.90 |
| CX-725-6 | 6 | 12 | 13 | 5.32 |
| CX-725-8 | 8 | 12 | 15 1/4 | 11.20 |
| CX-725-10 | 10 | 12 | 18 1/4 | 13.50 |
| CX-725-12 | 12 | 12 | 20 3/4 | 22.00 |
| CX-725-14 | 14 | 12 | 21 | 35.00 |

Standard Finish – GoldGalv®, unless otherwise stated.

C-720P — PVC-Coated Riser Clamp

The C-720P is normally used for the support of uninsulated vertical piping where no movement will occur. PVC coating the contact surface prevents galvanic corrosion with the pipe. Please use our C-720 for carbon steel piping or CT-720 for copper tubing requirements.

Note: This product is not designed to be supported with rods. Install using the maximum suggested torque values shown in the Technical Section of this catalog.

Specifications

- Material: Carbon Steel
- Compliance: Federal Specification A-A-1192A Type 8, MSS-SP-69 T 1400° F/600° C
- Finish: Polyvinyl Chloride
- Ordering: Specify pipe size and catalog number

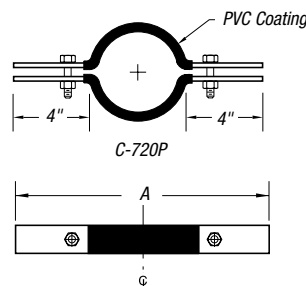

| CAT. NO. | PIPE SIZE (IN.) | MAX. LOAD (LBS.) | A (IN.) | WT. EACH (LBS.) |
|--------------|-----------------|------------------|---------|-----------------|
| C720P-1/2 | 1/2 | 225 | 9 5/8 | 1.30 |
| C-720P-3/4 | 3/4 | 225 | 9 5/8 | 1.36 |
| C-720P-1 | 1 | 225 | 9 5/8 | 1.38 |
| C-720P-1-1/4 | 1 1/4 | 225 | 10 | 1.95 |
| C-720P-1-1/2 | 1 1/2 | 225 | 10 5/8 | 2.01 |
| C-720P-2 | 2 | 225 | 10 3/4 | 2.17 |
| C-720P-2-1/2 | 2 1/2 | 390 | 11 1/4 | 2.29 |
| C-720P-3 | 3 | 530 | 12 | 2.50 |
| C-720P-4 | 4 | 810 | 13 1/2 | 3.42 |

Standard Finish – GoldGalv®, unless otherwise stated.

Pipe Straps, Conduit Clamps and Hangers

CT-720 — Copper Riser Clamp

Normally used for the support of uninsulated vertical tubing where no movement will occur. Please use C-720 for carbon steel piping or C-720P for plastic coating requirements.

Note: This product is not designed to be supported with rods. Install using the maximum suggested torque values shown in the Technical Section of this catalog.

Specifications

- Material: Carbon Steel
- Finish: Copper
- Compliance: Federal Specification A-A-1192A Type 8, MSS-SP-69 Type 8
- Ordering: Specify tubing size and catalog number

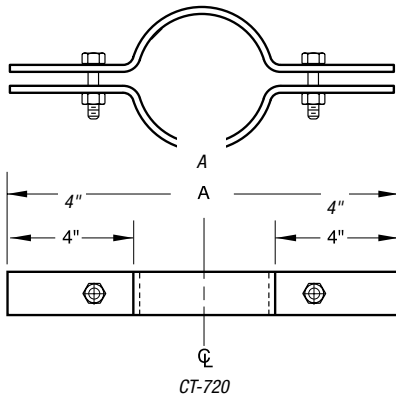

| CAT. NO. | TUBE SIZE (IN.) | MAX. LOAD (LBS.) | A (IN.) | WT. EACH (LBS.) |
|--------------|-------------------------------|------------------|--------------------------------|-----------------|
| CT-720-1/2 | 1/2 | 220 | 9 ⁹ / ₁₆ | .70 |
| CT-720-3/4 | 3/4 | 220 | 9 ⁹ / ₁₆ | .74 |
| CT720 1 | 1 | 220 | 9 ¹ / ₂ | .75 |
| CT-720-1-1/4 | 1 ¹ / ₄ | 220 | 9 ³ / ₄ | .77 |
| CT-720-1-1/2 | 1 ¹ / ₂ | 220 | 10 ¹ / ₈ | .80 |
| CT-720-2 | 2 | 220 | 10 ¹ / ₂ | .84 |
| CT-720-2-1/2 | 2 ¹ / ₂ | 390 | 11 | 1.60 |
| CT-720-3 | 3 | 530 | 11 ⁵ / ₈ | 1.80 |
| CT-720-3-1/2 | 3 ¹ / ₂ | 530 | 12 ⁵ / ₈ | 1.95 |
| CT-720-4 | 4 | 530 | 13 ⁵ / ₈ | 2.04 |
| CT-720-5 | 5 | 810 | 14 | 3.50 |
| CT-720-6 | 6 | 1,570 | 15 | 5.25 |

Standard Finish — GoldGalv®, unless otherwise stated.

C-724 — Ductile Iron Pipe Clamp

Can be used to secure mechanical joint piping or socket fittings together to prevent separation under pressure either under or above ground, vertically or horizontally. If used in this fashion, two (2) W-724 Socket Clamp Washers and Figure 133 Rods are also required, but must be ordered separately. The C-724 may also be used to support and guide vertical ductile iron pipe.

Specifications

- Materials: Carbon Steel
- Ordering: Specify pipe size, catalog number and finish
- Finish: Standard Finish — GoldGalv®, Black (add suffix "-B"), Electro-Galvanized (add suffix "-EG")

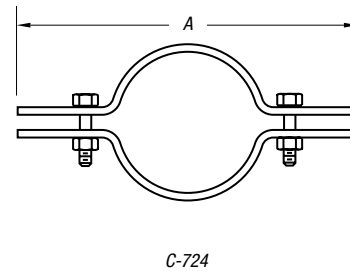

| CAT. NO. | PIPE SIZE (IN.) | ACTUAL PIPE O.D. | A (IN.) | WASHER SIZE (IN.) | WT. EACH (LBS.) |
|----------|-----------------|------------------|--------------------------------|-------------------------------|-----------------|
| C-724-3 | 3 | 3.96 | 12 ¹ / ₄ | 3/4 | 9.00 |
| C-724-4 | 4 | 4.8 | 13 ³ / ₄ | 3/4 | 9.00 |
| C-724-6 | 6 | 6.9 | 15 ³ / ₄ | 3/4 | 10.70 |
| C-724-8 | 8 | 9.05 | 18 | 3/4 | 12.20 |
| C-724-10 | 10 | 11.1 | 20 ⁵ / ₈ | 3/4 | 14.60 |
| C-724-12 | 12 | 13.2 | 22 ⁷ / ₈ | 3/4 | 16.60 |
| C-724-14 | 14 | 15.3 | 25 ¹ / ₂ | 1 ¹ / ₄ | 41.90 |
| C-724-16 | 16 | 17.4 | 28 | 1 ¹ / ₄ | 61.90 |
| C-724-18 | 18 | 19.5 | 33 | 1 ¹ / ₄ | 65.10 |
| C-724-20 | 20 | 21.6 | 35 ¹ / ₂ | 1 ¹ / ₂ | 92.20 |
| C-724-24 | 24 | 25.8 | 40 ¹ / ₂ | 1 ¹ / ₂ | 122.70 |
| C-724-30 | 30 | 32 | 48 | 1 ¹ / ₂ | 184.00 |

Standard Finish — GoldGalv®, unless otherwise stated.

Pipe Straps, Conduit Clamps and Hangers

C-725 — Two-Bolt Pipe Clamp

Designed to suspend cold or hot pipe lines where little or no insulation is required. The C-725 is usually used with an E-120-A Weldless Eyerut or E-157 Welded Eyerod. See Figure 298 heavy-duty Two-Bolt Clamp when higher loads are required. We will also design to meet special requirements such as special pipe sizes.

Rated Loads are for up to 750° F (399° C).

Specifications

- Material: Carbon Steel
- Compliance: Federal Specification A-A-1192A Type 4, MSS-SP-69 Type 4 and BSPSS-BS3974
- Finish: Standard Finish – GoldGalv®, Black (add suffix “-B”), Electro-Galvanized (add suffix “-EG”)
- Ordering: Specify catalog number, finish and pipe size. Also, include any special requirements for C-725

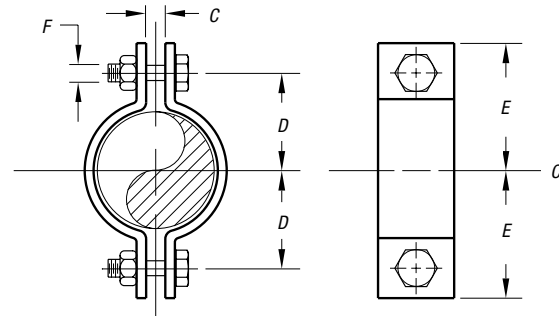

C-726

| CAT. NO. | PIPE SIZE (IN.) | MAXIMUM LOAD | | C (IN.) | ROD TAKE OUT D (IN.) | E (IN.) | F (IN.) | WT. EACH (LBS.) |
|-------------|-----------------|---------------|---------------|---------|-------------------------|---------|---------|--------------------|
| | | 650° F/343° C | 750° F/343° C | | | | | |
| C725 1/2 | 1/2 | 500 | 445 | 3/8 | 1 1/8 | 1 1/8 | 3/8 | .31 |
| C-725-3/4 | 3/4 | 500 | 445 | 3/8 | 1 1/4 | 1 3/4 | 3/8 | .35 |
| C-725-1 | 1 | 500 | 445 | 3/8 | 1 3/8 | 1 7/8 | 3/8 | .39 |
| C-725-1-1/4 | 1 1/4 | 500 | 445 | 3/8 | 1 7/8 | 2 1/8 | 3/8 | .40 |
| C-725-1-1/2 | 1 1/2 | 800 | 715 | 3/8 | 1 3/4 | 2 1/4 | 3/8 | .45 |
| C-725-2 | 2 | 1,040 | 930 | 1/2 | 2 1/8 | 2 3/8 | 1/2 | 1.23 |
| C-725-2-1/2 | 2 1/2 | 1,040 | 930 | 5/8 | 2 3/8 | 3 1/8 | 1/2 | 1.33 |
| C-725-3 | 3 | 1,040 | 930 | 5/8 | 3 | 3 1/2 | 1/2 | 1.53 |
| C-725-4 | 4 | 1,040 | 930 | 3/4 | 3 3/8 | 4 1/8 | 1/2 | 2.20 |
| C-725-5 | 5 | 1,040 | 930 | 3/4 | 4 1/4 | 5 | 1/2 | 2.39 |
| C-725-6 | 6 | 1,615 | 1,440 | 7/8 | 5 1/4 | 6 1/4 | 3/4 | 5.87 |
| C-725-8 | 8 | 1,615 | 1,440 | 1 | 6 3/8 | 7 3/8 | 3/4 | 6.95 |
| C-725-10 | 10 | 2,490 | 2,220 | 1 | 7 3/8 | 8 3/4 | 7/8 | 14.39 |
| C-725-12 | 12 | 2,490 | 2,220 | 1 1/8 | 8 3/4 | 10 1/4 | 7/8 | 16.73 |
| C-725-14 | 14 | 2,490 | 2,220 | 1 1/8 | 9 1/4 | 10 3/8 | 7/8 | 21.26 |
| C-725-16 | 16 | 2,490 | 2,220 | 1 1/8 | 10 1/4 | 11 1/8 | 7/8 | 23.39 |
| C-725-18 | 18 | 3,060 | 2,730 | 1 1/4 | 11 1/8 | 13 | 1 | 32.96 |
| C-725-20 | 20 | 3,060 | 2,730 | 1 3/8 | 12 3/4 | 14 1/8 | 1 1/8 | 36.74 |
| C-725-24 | 24 | 3,060 | 2,730 | 1 1/2 | 15 1/4 | 16 3/8 | 1 1/8 | 52.96 |
| C-725-30 | 30 | 3,500 | 3,360 | 2 | 18 1/2 | 20 3/4 | 1 1/2 | 103.50 |

Standard Finish – GoldGalv®, unless otherwise stated.

Pipe Straps, Conduit Clamps and Hangers

C-726 — Three-Bolt Pipe Clamp

Designed for hot-insulated pipe lines up to 750° F. The spacer on the top inner bolt provides uniform space for the connecting eyerod or weldless eyenut. We will also design to meet special requirements such as special pipe sizes.

Rated Loads are for up to 750° F (399° C).

Specifications

- Material: Carbon Steel
- Federal Specification A-A-1192A Type 3, MSS-SP-69 Type 3 and BSPSS-BS3974
- Finish: Standard Finish – GoldGalv®, Black (add suffix “-B”), Electro-Galvanized (add suffix “-EG”)
- Ordering: Specify catalog number, finish and pipe size. Also, include any special requirements

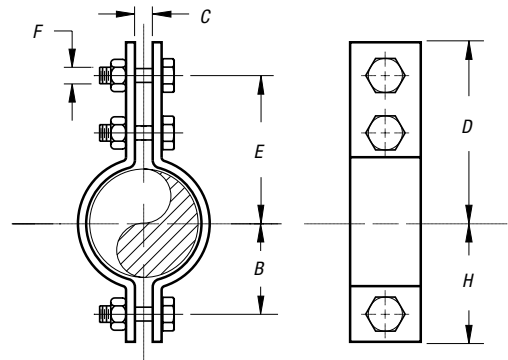

C-726

| CAT. NO. | PIPE SIZE (IN.) | MAXIMUM LOAD | | B (IN.) | C (IN.) | D (IN.) | TAKE OUT E (IN.) | F (IN.) | H (IN.) | WT. EACH (LBS.) |
|-------------|-----------------|---------------|---------------|---------|---------|---------|------------------|---------|---------|-----------------|
| | | 650° F/343° C | 750° F/399° C | | | | | | | |
| C-726-1/2 | 1/2 | 950 | 845 | 1 | 5/8 | 2 1/8 | 2 1/4 | 3/8 | 1 3/8 | .61 |
| C-726-3/4 | 3/4 | 950 | 845 | 1 1/8 | 5/8 | 3 1/4 | 2 1/2 | 3/8 | 1 3/4 | .66 |
| C-726-1 | 1 | 950 | 845 | 1 1/2 | 5/8 | 3 3/4 | 2 1/2 | 3/8 | 2 1/4 | .69 |
| C-726-1/4 | 1 1/4 | 950 | 845 | 1 1/2 | 3/4 | 3 3/8 | 2 1/8 | 3/8 | 2 1/4 | .75 |
| C-726-1-3/4 | 1 3/4 | 1,545 | 1,380 | 1 3/4 | 1 | 4 7/8 | 4 1/4 | 5/8 | 2 1/2 | 2.14 |
| C-726-2 | 2 | 1,545 | 1,380 | 2 1/4 | 1 1/4 | 5 1/8 | 5 1/4 | 5/8 | 2 3/4 | 2.43 |
| C-726-2-3/4 | 2 3/4 | 1,545 | 1,380 | 2 1/4 | 1 1/4 | 6 1/4 | 5 3/8 | 5/8 | 3 | 2.92 |
| C-726-3 | 3 | 1,545 | 1,380 | 2 3/4 | 1 1/4 | 6 5/8 | 6 | 5/8 | 3 1/2 | 3.19 |
| C-726-4 | 4 | 2,500 | 2,230 | 3 3/8 | 1 | 7 3/8 | 6 1/2 | 3/4 | 4 1/2 | 7.12 |
| C-726-5 | 5 | 2,500 | 2,230 | 4 | 1 1/4 | 8 1/4 | 7 | 3/4 | 5 1/4 | 7.96 |
| C-726-6 | 6 | 2,865 | 2,555 | 4 3/4 | 1 1/4 | 9 5/8 | 8 1/4 | 7/8 | 6 1/4 | 11.85 |
| C-726-8 | 8 | 2,865 | 2,555 | 5 3/4 | 1 1/4 | 10 5/8 | 9 1/4 | 7/8 | 7 1/4 | 13.59 |
| C-726-10 | 10 | 3,240 | 2,890 | 6 3/8 | 1 1/4 | 12 | 10 1/2 | 1 | 8 1/4 | 21.33 |
| C-726-12 | 12 | 3,240 | 2,890 | 8 3/8 | 1 1/2 | 13 | 11 1/2 | 1 | 9 5/8 | 23.65 |
| C-726-14 | 14 | 4,300 | 3,835 | 9 1/4 | 2 | 14 3/8 | 12 3/4 | 1 1/4 | 10 3/4 | 38.78 |
| C-726-16 | 16 | 4,300 | 3,835 | 10 | 2 | 15 5/8 | 14 | 1 1/4 | 11 1/4 | 42.89 |
| C-726-18 | 18 | 4,300 | 3,835 | 11 3/8 | 2 | 16 3/4 | 15 1/4 | 1 1/4 | 13 1/4 | 46.35 |
| C-726-20 | 20 | 4,500 | 4,015 | 12 3/8 | 2 | 17 1/2 | 15 5/8 | 1 3/8 | 14 | 58.67 |
| C-726-24 | 24 | 5,490 | 4,900 | 14 3/4 | 2 | 19 3/8 | 17 3/8 | 1 1/2 | 16 3/8 | 89.32 |
| C-726-30 | 30 | 7,500 | 6,690 | 18 1/2 | 1 1/2 | 26 3/8 | 23 3/8 | 1 1/2 | 21 | 140.89 |
| C-726-36 | 36 | 1,0500 | 9,360 | 22 1/2 | 3 | 32 1/4 | 28 3/4 | 1 3/4 | 26 | 246.44 |

Standard Finish – GoldGalv® unless otherwise stated.

Pipe Straps, Conduit Clamps and Hangers

Pipe Clamps — A-726, Alloy Three-Bolt Pipe Clamp

Designed for hot-insulated pipelines. The spacer on the top inner bolt provides uniform space for the connecting eyerod or weldless eyenut.

Temperature range: above 750° F (399° C) to 1050° F (566° C).

Specifications

- Material: Chromium Molybdenum Steel, ASTM A-387 Grade 22
- Compliance: Federal Specification A-A-1192A Type 3, MSS-SP-69 Type 3 and BSPSS-BS3974
- Finish: Standard Finish – GoldGalv®, Black (add suffix “-B”), Electro-Galvanized (add suffix “-EG”)
- Ordering: Specify catalog number and pipe size

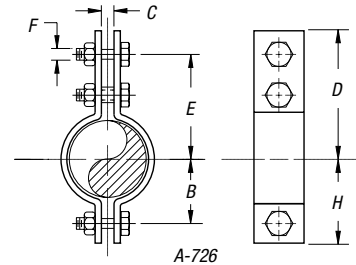

| CAT. NO. | PIPE SIZE (IN.) | MAXIMUM LOAD | | | B (IN.) | C (IN.) | D (IN.) | TAKE OUT E (IN.) | F (IN.) | H (IN.) | (LBS.) |
|-------------|-----------------|---------------|----------------|----------------|---------|---------|---------|------------------|---------|---------|--------|
| | | 950° F/510° C | 1000° F/538° C | 1050° F/566° C | | | | | | | |
| A-726-3/4 | ¾ | 870 | 600 | 440 | 1½ | ¾ | 3 | 2½ | ¾ | 1½ | 1.09 |
| A-726-1 | 1 | 870 | 600 | 440 | 1¼ | ¾ | 3½ | 2½ | ¾ | 1¾ | 1.14 |
| A-726-1-1/4 | 1¼ | 870 | 600 | 440 | 1½ | ¾ | 3¾ | 2½ | ¾ | 2¼ | 1.23 |
| A-726-1-1/2 | 1½ | 1,400 | 1,000 | 700 | 1¾ | 1 | 4½ | 4½ | ¾ | 2½ | 2.48 |
| A-726-2 | 2 | 1,400 | 1,000 | 700 | 2½ | 1 | 5½ | 5½ | ¾ | 2¾ | 2.70 |
| A-726-2-1/2 | 2½ | 1,400 | 1,000 | 700 | 2¾ | 1 | 6½ | 5½ | ¾ | 3 | 2.76 |
| A-726-3 | 3 | 1,400 | 1,000 | 700 | 2¾ | 1 | 6¾ | 6 | ¾ | 3½ | 3.19 |
| A-726-4 | 4 | 2,300 | 1,600 | 1,100 | 3¾ | 1 | 7¾ | 6½ | ¾ | 4½ | 7.30 |
| A-726-5 | 5 | 2,300 | 1,600 | 1,100 | 4 | 1½ | 8½ | 7 | ¾ | 5½ | 7.96 |
| A-726-6 | 6 | 2,600 | 1,800 | 1,300 | 4¾ | 1¼ | 10 | 8½ | ¾ | 6½ | 12.26 |
| A-726-8 | 8 | 2,600 | 1,800 | 1,300 | 5¾ | 1¼ | 11 | 9½ | ¾ | 7½ | 14.04 |
| A-726-10 | 10 | 3,000 | 2,100 | 1,500 | 6¾ | 1¼ | 12 | 10½ | 1 | 8¼ | 21.33 |
| A-726-12 | 12 | 3,000 | 2,100 | 1,500 | 8¾ | 1½ | 13¾ | 11½ | 1 | 9¾ | 24.00 |
| A-726-14 | 14 | 3,900 | 2,800 | 2,000 | 9¾ | 2 | 14¾ | 12¾ | 1¼ | 10¾ | 38.78 |
| A-726-16 | 16 | 3,900 | 2,800 | 2,000 | 10 | 2 | 15½ | 14 | 1¼ | 11¾ | 43.13 |
| A-726-18 | 18 | 39 | 2,800 | 2,000 | 11¾ | 2 | 16¾ | 15½ | 1¼ | 13¼ | 47.78 |
| A-726-20 | 20 | 5,000 | 3,200 | 2,000 | 12¾ | 2 | 17½ | 15½ | 1½ | 14 | 58.67 |
| A-726-24 | 24 | 5,500 | 3,500 | 2,700 | 14¾ | 1½ | 19¾ | 17½ | 1½ | 16¾ | 90.82 |

Standard Finish – GoldGalv®, unless otherwise stated.

Pipe Hangers — C-710, C-710F, C-710P, C-710SS

Designed to support non-insulated, stationary lines from above, allowing for approximately 1" to 1½" of vertical adjustment after the pipe is in place. The lower nut (not furnished) adjusts the pipe line to the proper elevation, the top nut (not furnished) prevents loosening due to vibration and must be tightened securely to assure proper hanger performance.

Rated Loads are for up to 650° F (343° C) for carbon steel. Maximum PVC temperature is 140° F (60° C).

Specifications

- Material: Carbon Steel (Also available in Stainless Steel as C-710SS)
- Compliance: Federal Specification A-A-1192A Type 1, MSS-SP-69 Type 1, BSPSS-BS3974, UL and FM
- Finish: Standard Finish – GoldGalv®, Black (add suffix “-B”), Electro-Galvanized (add suffix “-EG”)
- Ordering: Specify catalog number, finish and pipe size

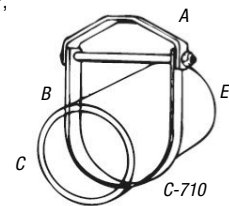

| CAT. NO. | PIPE SIZE (IN.) | MAX. LOAD (LBS.) | A (IN.) | B (IN.) | C (IN.) | ROD TAKE OUT E (IN.) | WT. EACH (LBS.) |
|-------------|-----------------|------------------|---------|---------|---------|----------------------|-----------------|
| C-710-1/2 | ½ | 610 | ¾ | 2¼ | 3½ | 1½ | .27 |
| C-710-3/4 | ¾ | 610 | ¾ | 2½ | 2¾ | 1½ | .29 |
| C-710-1 | 1 | 610 | ¾ | 3 | 3¾ | 2¼ | .33 |
| C-710-1-1/4 | 1¼ | 610 | ¾ | 3½ | 4 | 2¼ | .36 |
| C-710-1-1/2 | 1½ | 610 | ¾ | 3¾ | 4¼ | 2¾ | .42 |
| C-710-2 | 2 | 610 | ¾ | 3¾ | 4½ | 3½ | .52 |
| C-710-2-1/2 | 2½ | 1,130 | ½ | 4½ | 5½ | 3½ | .61 |
| C-710-3 | 3 | 1,130 | ½ | 5 | 6¼ | 4½ | .90 |
| C-710-3-1/2 | 3½ | 1,130 | ½ | 4½ | 6½ | 3½ | .99 |
| C-710-4 | 4 | 1,430 | ¾ | 5½ | 7¾ | 4½ | 1.40 |
| C-710-5 | 5 | 1,430 | ¾ | 6 | 8½ | 5 | 2.10 |
| C-710-6 | 6 | 1,940 | ¾ | 7 | 10½ | 5½ | 3.00 |

Standard Finish – GoldGalv®, unless otherwise stated.

| CAT. NO. | PIPE SIZE (IN.) | MAX. LOAD (LBS.) | A (IN.) | B (IN.) | C (IN.) | ROD TAKE OUT E (IN.) | WT. EACH (LBS.) |
|----------|-----------------|------------------|---------|---------|---------|----------------------|-----------------|
| C-710-7 | 7 | 2,000 | ¾ | 7½ | 11¼ | 6½ | 5.42 |
| C-710-8 | 8 | 2,000 | ¾ | 8½ | 12¾ | 6¾ | 5.25 |
| C-710-10 | 10 | 3,600 | ¾ | 10 | 15½ | 8¼ | 9.10 |
| C-710-12 | 12 | 3,800 | ¾ | 11½ | 17½ | 9¼ | 11.75 |
| C-710-14 | 14 | 4,200 | 1 | 12½ | 19½ | 10¾ | 14.25 |
| C-710-16 | 16 | 4,800 | 1 | 15 | 23 | 13½ | 20.75 |
| C-710-18 | 18 | 4,800 | 1¼ | 15¾ | 24¾ | 13¾ | 23.00 |
| C-710-20 | 20 | 4,800 | 1¼ | 17½ | 27½ | 15¼ | 41.50 |
| C-710-24 | 24 | 4,800 | 1¼ | 19½ | 31½ | 17½ | 50.00 |
| C-710-30 | 30 | 6,000 | 1¼ | 24¾ | 40¾ | 21¾ | 68.08 |
| C-710-36 | 36 | 9,500 | 1½ | 32½ | 50¾ | 30 | 68.68 |

Standard Finish – GoldGalv®, unless otherwise stated.

Pipe Straps, Conduit Clamps and Hangers

CL-710 — Light-Duty Clevis Hanger

Designed to support non-insulated, stationary lines from above, allowing for approximately 1" to 1½" of vertical adjustment after the pipe is in place. The lower nut (not furnished) adjusts the pipe line to the proper elevation, the top nut (not furnished) prevents loosening due to vibration and must be tightened securely to assure proper hanger performance.

Specifications

- Material: Carbon Steel
- Compliance: Federal Specification A-A-1192A Type 1, MSS-SP-69 Type 1
- Finish: Standard Finish – GoldGalv®, Black (add suffix "-B"), Electro-Galvanized (add suffix "-EG")
- Ordering: Specify catalog number, finish and pipe size

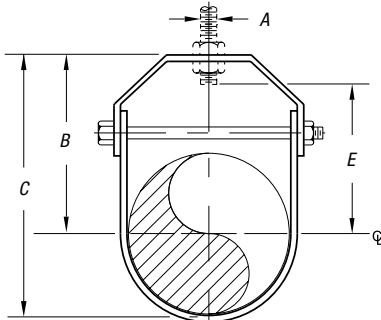

CL-710

CTL-710 — Copper Clevis Hanger

Designed to support non-insulated, stationary copper tubing lines from above, allowing for approximately 1" to 1½" of vertical adjustment after the tubing is in place. The lower nut (not furnished) adjusts the pipe line to the proper elevation. The top nut (not furnished) prevents loosening due to vibration and must be tightened securely to assure proper hanger performance.

Specifications

- Material: Carbon Steel
- Compliance: Federal Specification A-A-1192A Type 1, MSS-SP-69 Type 1 and BSPSS-BS3974. Rated Loads are for up to 650° F (343° C)
- Finish: Copper
- Ordering: Specify tubing size and catalog number

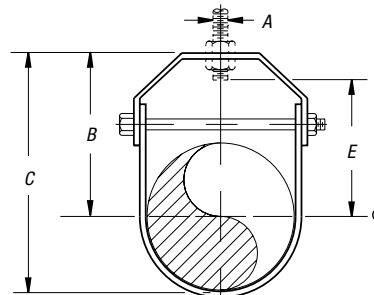

CTL-710

| CAT. NO. | PIPE SIZE (IN.) | MAX. LOAD (LBS.) | A (IN.) | B (IN.) | C (IN.) | E (IN.) | WT. EACH (LBS.) |
|--------------|-----------------|------------------|---------|---------|---------|---------|-----------------|
| CL710 1/2 | ½ | 150 | ¾ | 1½ | 2½ | ¾ | .27 |
| CL-710-3/4 | ¾ | 250 | ¾ | 2½ | 2½ | 1½ | .29 |
| CL-710-1 | 1 | 250 | ¾ | 2½ | 3¾ | 1½ | .33 |
| CL-710-1-1/4 | 1¼ | 250 | ¾ | 2½ | 3¾ | 2½ | .36 |
| CL-710-1-1/2 | 1½ | 250 | ¾ | 3 | 4 | 2¼ | .42 |
| CL-710-2 | 2 | 250 | ¾ | 3½ | 4¾ | 2¾ | .52 |
| CL-710-2-1/2 | 2½ | 350 | ½ | 4 | 5½ | 2½ | .81 |
| CL-710-3 | 3 | 350 | ½ | 4¼ | 6½ | 3¼ | .90 |
| CL-710-3-1/2 | 3½ | 350 | ½ | 4¾ | 6½ | 3¾ | .99 |
| CL-710-4 | 4 | 400 | ¾ | 5½ | 7½ | 4¾ | 1.40 |

Standard Finish – GoldGalv®, unless otherwise stated.

| CAT. NO. | PIPE SIZE (IN.) | MAX. LOAD (LBS.) | A (IN.) | B (IN.) | C (IN.) | ROD TAKE OUT E (IN.) | WT. EACH (LBS.) |
|---------------|-----------------|------------------|---------|---------|---------|----------------------|-----------------|
| CTL710 1/2 | ½ | 150 | ¾ | 2½ | 3½ | 2¼ | .16 |
| CTL-710-3/4 | ¾ | 250 | ¾ | 2½ | 3 | 1½ | .16 |
| CTL-710-1 | 1 | 250 | ¾ | 2½ | 3¾ | 1½ | .19 |
| CTL-710-1-1/4 | 1¼ | 250 | ¾ | 3¾ | 3¾ | 2½ | .22 |
| CTL-710-1-1/2 | 1½ | 250 | ¾ | 3¾ | 4¾ | 2½ | .29 |
| CTL-710-2 | 2 | 250 | ¾ | 3¾ | 4¾ | 2½ | .32 |
| CTL-710-2-1/2 | 2½ | 350 | ½ | 3¾ | 4¾ | 2½ | .72 |
| CTL-710-3 | 3 | 350 | ½ | 3¾ | 5¾ | 2½ | .82 |
| CTL-710-3-1/2 | 3½ | 350 | ½ | 4¾ | 5¾ | 3¾ | .91 |
| CTL-710-4 | 4 | 350 | ½ | 4½ | 6¼ | 3½ | 1.07 |
| CTL-710-5 | 5 | 900 | ¾ | 5 | 7¾ | 3¾ | 1.76 |
| CTL-710-6 | 6 | 900 | ¾ | 5¾ | 8¾ | 4¾ | 1.92 |

Standard Finish – GoldGalv®, unless otherwise stated.

Pipe Straps, Conduit Clamps and Hangers

ETL-710 — Light-Duty Clevis Hanger

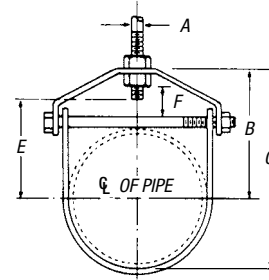
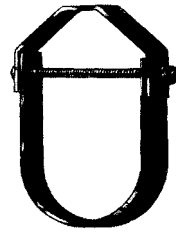

| CAT. NO. | TUBING SIZE (IN.) | MATERIAL SIZE | DIMENSIONS (IN.) | | | | | STD. CTN. |
|---------------|-------------------|---------------|------------------|----------|----------|-------|--------|-----------|
| | | | A | B | C | E | F | |
| ETL710 1/2 | 1/2 | 16 ga x 7/8 | 3/8 | 1 13/16 | 2 3/8 | 1 1/4 | 9/16 | 100 |
| ETL-710-3/4 | 3/4 | 16 ga x 7/8 | 3/8 | 1 1/4 | 2 1/4 | 1 1/4 | 9/16 | 100 |
| ETL-710-1 | 1 | 16 ga x 7/8 | 3/8 | 1 5/8 | 2 3/8 | 1 1/8 | 1/2 | 100 |
| ETL-710-1-1/4 | 1 1/4 | 16 ga x 7/8 | 3/8 | 2 | 2 3/4 | 1 1/8 | 1 1/16 | 100 |
| ETL-710-1-1/2 | 1 1/2 | 16 ga x 7/8 | 3/8 | 2 1/8 | 3 1/8 | 1 1/4 | 1 | 100 |
| ETL-710-2 | 2 | 13 ga x 7/8 | 3/8 | 2 1 1/16 | 4 | 1 1/2 | 1 1/16 | 100 |
| ETL-710-2-1/2 | 2 1/2 | 1/8 x 1 1/4 | 1/2 | 3 1/4 | 4 1 1/16 | 2 | 1 1/8 | 100 |
| ETL-710-3 | 3 | 1/8 x 1 1/4 | 1/2 | 3 1/2 | 5 3/16 | 2 1/4 | 1 3/16 | 100 |
| ETL-710-3-1/2 | 3 1/2 | 1/8 x 1 1/4 | 1/2 | 3 3/4 | 5 1 1/16 | 2 1/2 | 1 1/8 | 100 |
| ETL-710-4 | 4 | 1/8 x 1 1/4 | 1/2 | 4 5/16 | 6 1/2 | 3 | 1 3/16 | 100 |
| ETL-710-5 | 5 | 3/16 x 1 1/4 | 5/8 | 5 | 7 1 1/16 | 3 3/8 | 1 3/16 | 50 |
| ETL-710-6 | 6 | 3/16 x 1 1/4 | 5/8 | 5 1 1/16 | 8 3/8 | 4 1/8 | 1 1/4 | 50 |

Standard Finish – GoldGalv®.

Carbon Steel.

Copper tube sized.

For the suspension of stationary copper tubing lines. Order by Cat. No., tubing size.

CI-710 — Clevis Hanger for Ductile Iron and A.W.W.A. Cast Iron Pipe

Designed to support non-insulated, stationary ductile iron and A.W.W.A. cast iron lines from above, allowing for approximately 1" to 1 1/2" of vertical adjustment after the pipe is in place. The lower nut (not furnished) adjusts the pipe line to the proper elevation. The top nut (not furnished) prevents loosening due to vibration and must be tightened securely to assure proper hanger performance.

Specifications

- Material: Carbon Steel
- Compliance: MSS-SP-69 Type 1, A-A-1192A Type 1
- Finish: Standard Finish – GoldGalv®, Black (add suffix "-B"), Electro-Galvanized (add suffix "-EG")
- Ordering: Specify pipe size, catalog number and finish

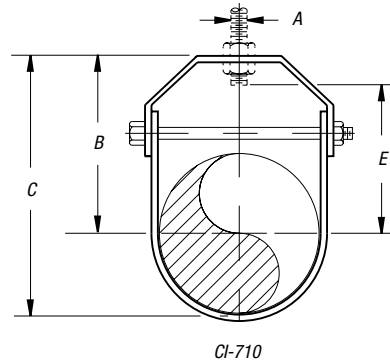

CI-710

| CAT. NO. | PIPE SIZE (IN.) | MAX. LOAD (LBS.) | DIMENSIONS (IN.) | | | ROD TAKE OUT E (IN.) | WT. EACH (LBS.) |
|-----------|-----------------|------------------|------------------|--------|--------|----------------------|-----------------|
| | | | A | B | C | | |
| CI-710-4 | 4 | 1,430 | 3/4 | 5 3/4 | 8 1/8 | 4 3/8 | 2.08 |
| CI-710-6 | 6 | 1,940 | 7/8 | 7 | 10 3/8 | 5 1/2 | 2.78 |
| CI-710-8 | 8 | 2,000 | 7/8 | 9 1/4 | 13 3/4 | 7 3/4 | 4.47 |
| CI-710-10 | 10 | 3,600 | 7/8 | 10 1/4 | 15 3/4 | 8 3/8 | 8.87 |
| CI-710-12 | 12 | 3,800 | 7/8 | 12 5/8 | 19 1/4 | 11 | 12.0 |
| CI-710-14 | 14 | 4,200 | 1 | 14 1/8 | 21 3/4 | 12 1/4 | 15.2 |
| CI-710-16 | 16 | 4,800 | 1 | 14 7/8 | 23 3/8 | 13 | 23.6 |
| CI-710-18 | 18 | 4,800 | 1 1/4 | 16 1/2 | 26 1/4 | 14 1/2 | 25.9 |
| CI-710-20 | 20 | 4,800 | 1 1/4 | 18 3/4 | 29 1/2 | 16 1/2 | 44.3 |
| CI-710-24 | 24 | 4,800 | 1 1/4 | 21 1/8 | 34 3/4 | 19 1/2 | 53.5 |

Standard Finish – GoldGalv®, unless otherwise stated.

Pipe Straps, Conduit Clamps and Hangers

C-711 — J Pipe Hanger

Standard Finish – GoldGalv® brand

Complies with Specification MSS SP 58, Type 5. Sizes through 5" conform to Ca. Code Title 24, Div. T22 for seismic restraint bracing.

C-711F — Felt-Lined J Pipe Hanger

Standard Finish – GoldGalv® brand

Available in sizes up to 8".

C-711P — Plastic-Coated J Pipe Hanger

Standard Finish – GoldGalv® brand

Isolates hanger from glass and other piping for corrosion or cushioning purposes. Available in sizes up to 4". Order by Cat. No. and pipe size. Hole provided for side mounting to wall as bracket.

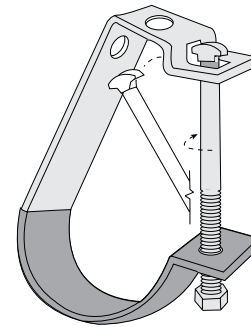
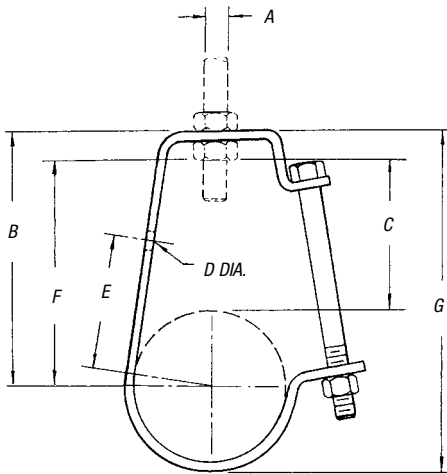

Standard

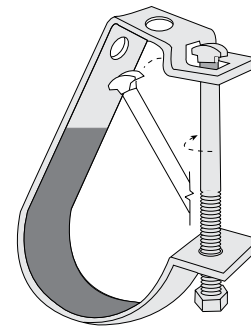

Felt Lined

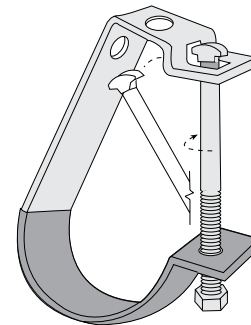

Plastic Coated

| CAT. NO. | PIPE SIZE (IN.) | A ROD SIZE (IN.) | DIMENSIONS (IN.) | | | | | BOLT SIZE (IN.) | G (IN.) | STOCK SIZE | MAX REC LOADS (LBS.) | STD. CTN. |
|-------------|-----------------|------------------|------------------|---------|------|---------|---------|-----------------|----------|---------------|----------------------|-----------|
| | | | B | C | D | E | F | | | | | |
| C-711-1/2 | 1/2 | 3/8 | 2 5/8 | 1 3/4 | 7/16 | 1 1/2 | 1 15/16 | 1/4 | 3 5/32 | 12 ga x 3/4 | 400 | 50 |
| C-711-3/4 | 3/4 | 3/8 | 2 7/8 | 1 7/8 | 7/16 | 1 11/16 | 2 1/8 | 1/4 | 3 1/2 | 12 ga x 3/4 | 400 | 50 |
| C-711-1 | 1 | 3/8 | 2 15/16 | 1 15/16 | 7/16 | 1 13/16 | 2 3/8 | 1/4 | 3 11/16 | 12 ga x 3/4 | 400 | 50 |
| C-711-1-1/4 | 1 1/4 | 3/8 | 3 1/4 | 2 | 7/16 | 2 1/8 | 2 5/8 | 1/4 | 4 1/8 | 12 ga x 3/4 | 400 | 50 |
| C-711-1-1/2 | 1 1/2 | 3/8 | 3 9/16 | 2 3/16 | 7/16 | 2 1/8 | 2 7/8 | 1/4 | 4 5/8 | 12 ga x 3/4 | 400 | 50 |
| C-711-2 | 2 | 3/8 | 3 11/16 | 2 1/8 | 7/16 | 2 9/16 | 3 1/8 | 1/4 | 5 | 12 ga x 3/4 | 400 | 50 |
| C-711-2-1/2 | 2 1/2 | 1/2 | 4 7/16 | 2 7/16 | 9/16 | 3 3/16 | 3 5/8 | 3/8 | 6 | 12 ga x 1 1/4 | 500 | 25 |
| C-711-3 | 3 | 1/2 | 4 13/16 | 2 9/16 | 9/16 | 3 1/2 | 4 1/8 | 3/8 | 6 21/32 | 12 ga x 1 1/4 | 500 | 25 |
| C-711-3-1/2 | 3 1/2 | 1/2 | 5 1/8 | 2 5/8 | 9/16 | 3 3/4 | 4 3/8 | 3/8 | 7 5/16 | 3/16 x 1 1/4 | 500 | 25 |
| C-711-4 | 4 | 5/8 | 6 1/8 | 3 9/16 | 9/16 | 4 5/8 | 5 3/16 | 3/8 | 8 9/16 | 3/16 x 1 1/4 | 550 | 10 |
| C-711-5 | 5 | 5/8 | 6 3/4 | 3 3/4 | 9/16 | 5 1/8 | 5 3/8 | 3/8 | 9 23/32 | 3/16 x 1 1/4 | 550 | 10 |
| C-711-6 | 6" | 3/4 | 7 3/4 | 3 9/16 | 9/16 | 5 13/16 | 6 3/8 | 3/8 | 11 1/4 | 3/16 x 1 3/4 | 600 | 10 |
| C-711-8 | 8" | 7/8 | 9 3/16 | 3 9/16 | 9/16 | 6 15/16 | 8 | 3/8 | 13 11/16 | 3/16 x 1 3/4 | 760 | 8 |

*Hangers 6" and over have hole instead of slot.

Pipe Straps, Conduit Clamps and Hangers

C-727 — Adjustable Swivel Ring

Designed for the support of non-insulated static pipe lines. The swivel nut is knurled to provide a gripping surface when adjusting the pipe elevation.

Specifications

- Compliance: Federal Specification A-A-1192A Type 10, MSS SP-69 Type 10, UL Listed and FM Approved (¾" through 8"). We also offer Swivel Ring hangers that are for Copper Tubing (CT-727), PVC coated (C-727-P) and for NFPA requirements (C-727-NFPA) in this catalog
- Material: Carbon Steel
- Finish: Standard Finish – Pre-Galv, Electro-Galvanized (add suffix "-EG") Black (add suffix "-B")
- Ordering: Specify pipe size, catalog number and finish

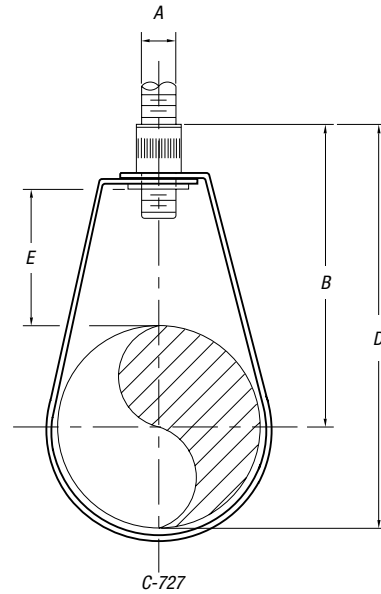

| CAT. NO. | PIPE SIZE (IN.) | MAX LOAD (LBS.) | DIMENSIONS (IN.) | | | | WT. EACH (LBS.) |
|-------------|-----------------|-----------------|------------------|----|-----|----|-----------------|
| | | | A | B | D | E | |
| C-727-1/2 | ½ | 300 | ⅜ | 2¾ | 3⅛ | 1⅛ | .09 |
| C-727-¾ | ¾ | 300 | ⅜ | 2½ | 3⅛ | 1⅛ | .10 |
| C-727-1 | 1 | 300 | ⅜ | 2½ | 3⅞ | 1 | .10 |
| C-727-1-1/4 | 1¼ | 300 | ⅜ | 2⅜ | 3⅞ | 1⅛ | .10 |
| C-727-1-1/2 | 1½ | 300 | ⅜ | 3⅛ | 3⅞ | 1⅛ | .11 |
| C-727-2 | 2 | 300 | ⅜ | 3⅞ | 4⅜ | 1⅛ | .12 |
| C-727-2-1/2 | 2½ | 600 | ½ | 3⅞ | 5⅞ | 1¼ | .32 |
| C-727-3 | 3 | 600 | ½ | 4 | 5⅞ | 1⅞ | .35 |
| C-727-3-1/2 | 3½ | 600 | ½ | 4⅞ | 6⅞ | 1½ | .39 |
| C-727-4 | 4 | 1,000 | ⅝ | 4⅞ | 7⅞ | 1¼ | .43 |
| C-727-5 | 5 | 1,000 | ⅝ | 5⅞ | 8½ | 1⅞ | .65 |
| C-727-6 | 6 | 1,250 | ¾ | 6⅞ | 10⅞ | 2 | 1.09 |
| C-727-8 | 8 | 1,800 | ⅞ | 8⅞ | 12⅞ | 2⅞ | 1.24 |

Standard Finish: Pre-Galv only.

Add "F" suffix for felt lining.

Pipe Straps, Conduit Clamps and Hangers

C-727-P — PVC-Coated Adjustable Swivel Ring

Designed for the support of non-insulated static pipe lines and to protect the pipe from coming into direct contact with the hanger by having the contact surface PVC coated. The swivel nut is knurled to provide a gripping surface when adjusting the pipe elevation.

Specifications

- Compliance: Federal Specification A-A-1192A Type 10, MSS SP-69 Type 10, UL Listed and FM Approved (¾" through 8")
 - Material: Carbon Steel
 - Finish: Standard Finish — GoldGalv®, Black (add suffix "-B"), Electro-Galvanized (add suffix "-EG")
 - Ordering: Specify pipe size and catalog number
- We also offer Swivel Ring hangers that are for Copper Tubing (CT-727) and for NFPA requirements (C-727-NFPA) in this catalog. Operating temperature should not exceed 140° F/60° C

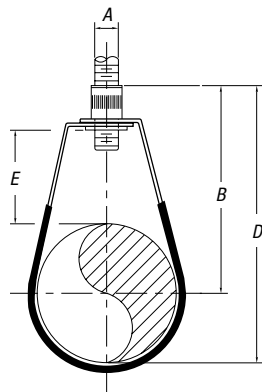

C-727-P

| CAT. NO. | PIPE SIZE (IN.) | MAX. LOAD (LBS.) | DIMENSIONS (IN.) | | | | WT. EACH (LBS.) |
|---------------|-----------------|------------------|------------------|----|-----|----|-----------------|
| | | | A | B | D | E | |
| C727P 1/2 | ½ | 300 | ¾ | 2¼ | 3¼ | 1¼ | .11 |
| C-727-P-3/4 | ¾ | 300 | ¾ | 2½ | 3¼ | 1½ | .13 |
| C-727-P-1 | 1 | 300 | ¾ | 2½ | 3¼ | 1 | .13 |
| C-727-P-1-1/4 | 1¼ | 300 | ¾ | 2¾ | 3¾ | 1¼ | .15 |
| C-727-P-1-1/2 | 1½ | 300 | ¾ | 3 | 3¾ | 1¼ | .17 |
| C-727-P-2 | 2 | 300 | ¾ | 3¼ | 4¾ | 1½ | .18 |
| C-727-P-2-1/2 | 2½ | 600 | ½ | 3¾ | 5½ | 1¼ | .34 |
| C-727-P-3 | 3 | 600 | ½ | 4 | 5½ | 1½ | .39 |
| C-727-P-3-1/2 | 3½ | 600 | ½ | 4¾ | 6½ | 1½ | .42 |
| C-727-P-4 | 4 | 1,000 | ¾ | 4¾ | 7½ | 1¼ | .48 |
| C-727-P-5 | 5 | 1,000 | ¾ | 5¾ | 8½ | 1¾ | .69 |
| C-727-P-6 | 6 | 1,250 | ¾ | 6¾ | 10½ | 2 | 1.13 |
| C-727-P-8 | 8 | 1,800 | ¾ | 8¾ | 12½ | 2½ | 1.29 |

Standard Finish — GoldGalv®, unless otherwise stated.

C-727-NFPA — NFPA Swivel Ring

Designed for the support of non-insulated static pipe lines. The swivel nut is knurled to provide a gripping surface when adjusting the tubing elevation and is tapped to the reduced rod standards of NFPA.

Specifications

- Compliance: Federal Specification A-A-1192A Type 10, MSS SP-69 Type 10, UL Listed and FM Approved (¾" through 8") and NFPA standards
 - Material: Carbon Steel
 - Finish: Standard Finish — GoldGalv®, Black (add suffix "-B"), Electro-Galvanized (add suffix "-EG")
 - Ordering: Specify pipe size, catalog number and finish
- We also offer Swivel Ring hangers that are for standard commercial pipe (C-727), copper tubing (CT-727) and PVC coated (C-727-P) in this catalog

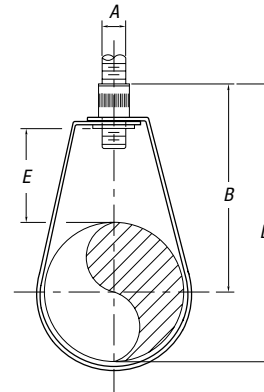

C-727-P

| CAT. NO. | PIPE SIZE (IN.) | MAX. LOAD (LBS.) | DIMENSIONS (IN.) | | | | WT. EACH (LBS.) |
|------------------|-----------------|------------------|------------------|----|-----|----|-----------------|
| | | | A | B | D | E | |
| C-727-NFPA-1/2 | ½ | 300 | ¾ | 2¼ | 3¼ | 1¼ | .09 |
| C-727-NFPA-3/4 | ¾ | 300 | ¾ | 2½ | 3¼ | 1½ | .10 |
| C-727-NFPA-1 | 1 | 300 | ¾ | 2½ | 3¼ | 1 | .10 |
| C-727-NFPA-1-1/4 | 1¼ | 300 | ¾ | 2¾ | 3¾ | 1¼ | .10 |
| C-727-NFPA-1-1/2 | 1½ | 300 | ¾ | 3 | 3¾ | 1¼ | .11 |
| C-727-NFPA-2 | 2 | 300 | ¾ | 3¼ | 4¾ | 1½ | .12 |
| C-727-NFPA-2-1/2 | 2½ | 525 | ¾ | 3¾ | 5 | 1¼ | .25 |
| C-727-NFPA-3 | 3 | 525 | ¾ | 3¾ | 5¾ | 1½ | .30 |
| C-727-NFPA-3-1/2 | 3½ | 525 | ¾ | 4¾ | 6½ | 1½ | .33 |
| C-727-NFPA-4 | 4 | 650 | ¾ | 4¾ | 7 | 1¾ | .41 |
| C-727-NFPA-5 | 5 | 1,000 | ½ | 5¾ | 8¾ | 2¼ | .58 |
| C-727-NFPA-6 | 6 | 1,000 | ½ | 6¾ | 9¾ | 2¼ | .92 |
| C-727-NFPA-8 | 8 | 1,000 | ½ | 7¾ | 12¼ | 2½ | 1.16 |

Standard Finish — GoldGalv®, unless otherwise stated.

Pipe Straps, Conduit Clamps and Hangers

CT-727 — Copper Tubing Swivel Ring

Designed for the support of non-insulated static copper tubing lines. The swivel nut is knurled to provide a gripping surface when adjusting the tubing elevation.

Specifications

- Compliance: Federal Specification A-A-1192A Type 10, MSS SP-69 Type 10. We also offer Swivel Ring hangers that are for carbon steel pipe (C-727), PVC coated (C-727-P) and for NFPA requirements (C-727-NFPA) in this catalog
- Material: Carbon Steel
- Finish: Copper
- Ordering: Specify copper tubing size

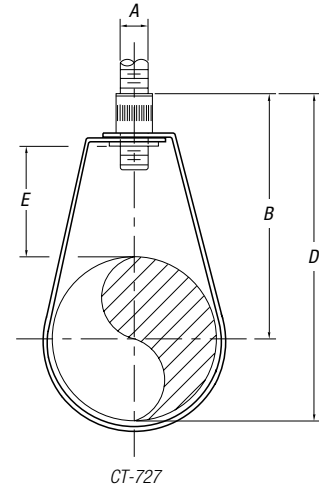

| CAT. NO. | PIPE SIZE (IN.) | MAX. LOAD (LBS.) | DIMENSIONS (IN.) | | | | WT. EACH (LBS.) |
|--------------|-----------------|------------------|------------------|---------|--------|---------|-----------------|
| | | | A | B | D | E | |
| CT727 1/2 | 1/2 | 300 | 3/8 | 2 3/8 | 3 1/4 | 1 11/16 | .11 |
| CT-727-3/4 | 3/4 | 300 | 3/8 | 2 3/8 | 3 1/8 | 1 3/8 | .11 |
| CT-727-1 | 1 | 300 | 3/8 | 2 1/2 | 3 1/8 | 1 | .11 |
| CT-727-1-1/4 | 1 1/4 | 300 | 3/8 | 2 3/4 | 3 1/4 | 1 1/8 | .13 |
| CT-727-1-1/2 | 1 1/2 | 300 | 3/8 | 2 15/16 | 3 3/8 | 1 1/8 | .13 |
| CT-727-2 | 2 | 300 | 3/8 | 3 3/16 | 4 1/8 | 1 1/8 | .15 |
| CT-727-2-1/2 | 2 1/2 | 525 | 3/8 | 4 | 4 3/8 | 1 1/8 | .16 |
| CT-727-3 | 3 | 525 | 1/2 | 4 9/16 | 5 3/16 | 1 3/16 | .32 |
| CT-727-3-1/2 | 3 1/2 | 525 | 1/2 | 4 9/16 | 5 5/8 | 1 1/8 | .35 |
| CT-727-4 | 4 | 650 | 1/2 | 5 5/16 | 6 1/2 | 1 3/16 | .38 |
| CT-727-5 | 5 | 1,000 | 1/2 | 6 1/4 | 8 3/8 | 1 3/8 | .58 |
| CT-727-6 | 6 | 1,000 | 1/2 | 7 3/16 | 9 3/16 | 2 1/4 | .92 |

Standard Finish — GoldGalv® unless otherwise stated.

ET-727 Copper Sized Adjustable Ring

Standard Finish — GoldGalv® barrier for separation of dissimilar metals. Available in sizes 1/2" through 2". Sized for Copper Tubing.

| CAT. NO. | TUBING SIZE (IN.) | ROD SIZE (IN.) | DIMENSIONS (IN.) | | | STOCK SIZE | MAX REC. LOAD (LBS.) | STD. CTN. |
|--------------|-------------------|----------------|------------------|-------|-------|----------------|----------------------|-----------|
| | | | A | B | C | | | |
| ET727 1/2 | 1/2 | 3/8 | 3 3/8 | 2 3/4 | 1 1/2 | 16 ga x 3/8 | 400 | 100 |
| ET-727-3/4 | 3/4 | 3/8 | 3 1/8 | 2 5/8 | 1 1/4 | 16 ga x 3/8 | 400 | 100 |
| ET-727-1 | 1 | 3/8 | 3 3/8 | 2 1/2 | 1 | 16 ga x 3/8 | 400 | 100 |
| ET-727-1-1/4 | 1 1/4 | 3/8 | 3 3/4 | 2 1/2 | 1 | 16 ga x 3/8 | 400 | 100 |
| ET-727-1-1/2 | 1 1/2 | 3/8 | 3 3/8 | 3 | 1 1/4 | 16 ga x 3/8 | 400 | 100 |
| ET-727-2 | 2 | 3/8 | 4 1/2 | 3 3/8 | 1 1/2 | 16 ga x 3/8 | 400 | 100 |
| ET-727-2-1/2 | 2 1/2 | 3/8* | 5 1/2 | 4 3/8 | 2 | 14 ga x 1 3/16 | 600 | 100 |
| ET-727-3 | 3 | 1/2 | 6 3/8 | 4 3/4 | 2 | 14 ga x 1 3/16 | 600 | 100 |
| ET-727-3-1/2 | 3 1/2 | 1/2 | 6 3/8 | 4 1/2 | 1 1/2 | 14 ga x 1 3/16 | 600 | 50 |
| ET-727-4 | 4 | 1/2* | 7 3/8 | 5 1/4 | 2 | 14 ga x 1 1/4 | 1,250 | 100 |
| ET-727-5 | 5 | 5/8 | 8 3/8 | 5 3/4 | 2 | 12 ga x 1 1/4 | 1,250 | 25 |
| ET-727-6 | 6 | 5/8 | 9 1/2 | 6 3/8 | 1 3/8 | 12 ga x 1 1/4 | 1,250 | 25 |

2 1/2" CT filled with water weighs less than 2" IP filled with water, 4" CT less than 3 1/2" IP with water.

2 1/2" CT available with 1/2" thread and 4" CT available with 3/8" thread for Government Specs.

Standard Finish — GoldGalv®, unless otherwise stated.

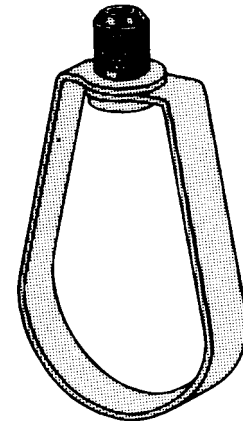

Pipe Straps, Conduit Clamps and Hangers

M-718, M-718-B — Extension Ring Hanger

M-718 — (Rod Tapped – Electro-Galvanized)

M-718-B — (Rod Tapped – Plain Finish)

This split ring hanger is designed for the support of non-insulated stationary pipe lines. Also available in a two-screw design. The MT-742-R Ceiling Plate is normally used with this product.

Specifications

- Material: Malleable Iron.
- Finish: Standard Finish – EG (silver), Black (add suffix “-B”), Electro-Galvanized (add suffix “-EG”).
- Compliance: Federal Specification A-A-1192A Type 12, MSS-SP-69 Type 12
- Ordering: Specify pipe size and catalog number.

| CAT. NO. | PIPE SIZE (IN.) | MAX LOAD (LBS.) | PIPE SIZE A (IN.) | ROD SIZE A (IN.) | B (IN.) | WT. EACH (LBS.) |
|-------------|-----------------|-----------------|-------------------|------------------|---------|-----------------|
| M-718-3/8 | 3/8 | 180 | 1/4 | 3/8 | 13/16 | .16 |
| M-718-1/2 | 1/2 | 180 | 1/4 | 3/8 | 7/8 | .17 |
| M-718-3/4 | 3/4 | 180 | 1/4 | 3/8 | 1 | .20 |
| M-718-1 | 1 | 180 | 1/4 | 3/8 | 1 1/8 | .21 |
| M-718-1-1/4 | 1 1/4 | 180 | 1/4 | 3/8 | 1 1/16 | .29 |
| M-718-1-1/2 | 1 1/2 | 180 | 1/4 | 3/8 | 1 5/16 | .31 |
| M-718-2 | 2 | 180 | 1/4 | 3/8 | 1 11/16 | .35 |
| M-718-2-1/2 | 2 1/2 | 480 | 1/2 | 1/2 | 2 1/8 | .57 |
| M-718-3 | 3 | 480 | 1/2 | 1/2 | 2 7/16 | .72 |
| M-718-4 | 4 | 480 | 1/2 | 1/2 | 3 1/8 | 1.16 |

Standard Finish – EG (silver).

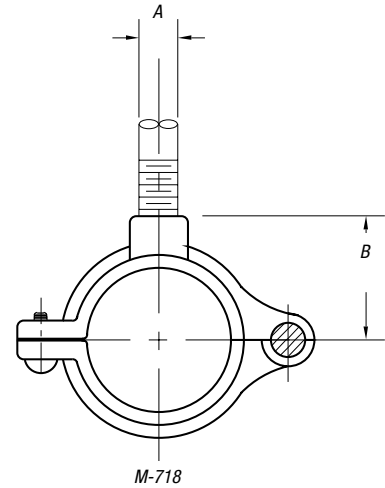

MT-718 — Copper Extension Ring Hanger

This split ring hanger is designed for the support of non-insulated copper tubing lines. The MT-718 is furnished tapped for bolt thread and is used with the MT-742-R Ceiling Plate. Also available in a two-bolt design.

Specifications

- Material: Malleable Iron
- Finish: Copper
- For Electro-Galvanizing please see M-718.
- Compliance: Federal Specification A-A-1192A Type 12, MSS-SP-69 Type 12
- Ordering: Specify tube size and catalog number.

| CAT. NO. | TUBE SIZE (IN.) | MAX LOAD (LBS.) | ROD SIZE A (IN.) | B (IN.) | WT. EACH (LBS.) |
|--------------|-----------------|-----------------|------------------|---------|-----------------|
| MT718-1/4 | 1/4 | 180 | 3/8 | 1/2 | .10 |
| MT-718-3/8 | 3/8 | 180 | 3/8 | 1/2 | .12 |
| MT-718-1/2 | 1/2 | 180 | 3/8 | 3/4 | .13 |
| MT-718-5/8 | 5/8 | 180 | 3/8 | 3/4 | .14 |
| MT-718-3/4 | 3/4 | 180 | 3/8 | 7/8 | .15 |
| MT-718-1 | 1 | 180 | 3/8 | 1 | .16 |
| MT-718-1-1/4 | 1 1/4 | 180 | 3/8 | 1 1/4 | .19 |
| MT-718-1-1/2 | 1 1/2 | 180 | 3/8 | 1 1/4 | .22 |
| MT-718-2 | 2 | 180 | 3/8 | 1 1/2 | .27 |
| MT-718-2-1/2 | 2 1/2 | 480 | 1/2 | 2 | .72 |
| MT-718-3 | 3 | 480 | 1/2 | 2 1/4 | 1.07 |

Standard Finish – GoldGalv®, unless otherwise stated.

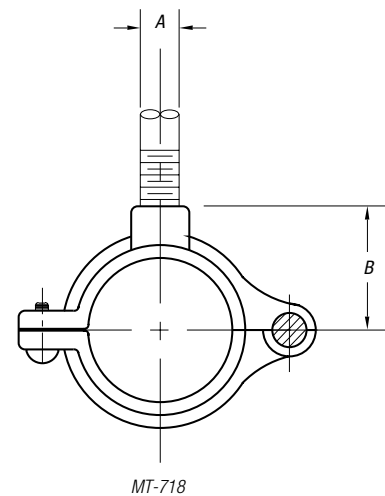

Pipe Straps, Conduit Clamps and Hangers

Seismic Bracing

(Consult Superstrut® Seismic Hanger bulletin for additional information.)

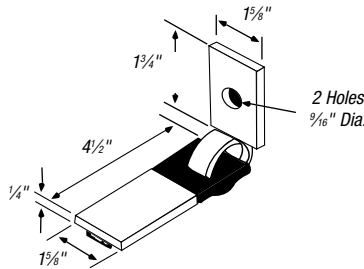

CAT. NO. C749N
Seismic Brace
1,500 lb. load safety factor of 3

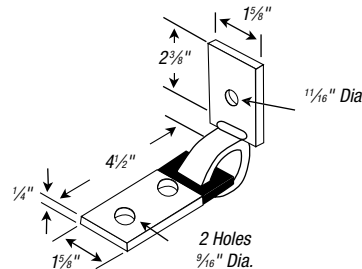

CAT. NO. C749N 5/8
Seismic Brace
1,650 lb. load safety factor of 3

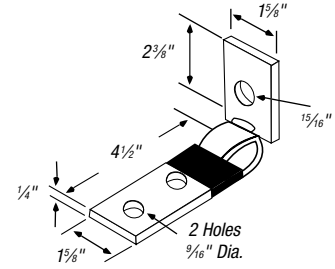

CAT. NO. C749N 7/8
Seismic Brace
1,650 lb. load safety factor of 3

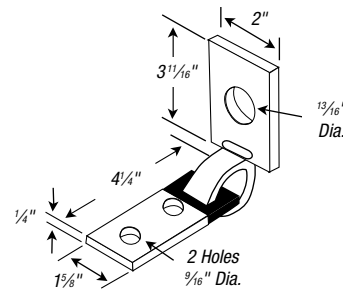

CAT. NO. C-749-N-1-1/8
Seismic Brace
1,650 lb. load safety factor of 3

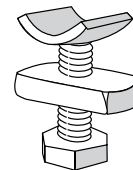

CAT. NO. ES-142
Size: 1/2" x 1 1/4" Bolt Size: 1/2"
Seismic bracing rod stiffener connector

All braces have plastisol coating on the flat member. Plastisol insulates against vibration noise transmission and eliminates rattle at the connection points.

Standard Finish – GoldGalv® brand. Approved for seismic applications.

S-720 — Adjustable Pipe Hanger

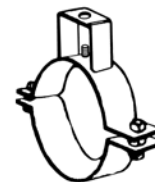

| CAT. NO. | PIPE SIZE (IN.) | ROD SIZE (IN.) | ADJUSTMENT (IN.) | BOLT CENTERS (IN.) | STOCK SIZE (IN.) | BOLT SIZE (IN.) | DESIGN LOAD (LBS.) | STD. CTN. |
|-------------|-----------------|----------------|------------------|--------------------|------------------|-----------------|--------------------|-----------|
| S720 3/4 | 3/4 | 3/8 | 1 5/8 | 4 1/2 | 3/16 X 1 1/4 | 1/2-1 1/4 | 550 | 10 |
| S-720-1 | 1 | 3/8 | 1 1/2 | 4 1/2 | 3/16 X 1 1/4 | 1/2-1 1/4 | 550 | 10 |
| S-720-1-1/4 | 1 1/4 | 3/8 | 1 3/8 | 5 | 3/16 X 1 1/4 | 1/2-1 1/4 | 550 | 10 |
| S-720-1-1/2 | 1 1/2 | 3/8 | 1 1/2 | 4 1/2 | 3/16 X 1 1/4 | 1/2-1 1/4 | 550 | 10 |
| S-720-2 | 2 | 3/8 | 1 1/2 | 5 | 1/4 X 1 1/4 | 1/2-1 1/4 | 700 | 10 |
| S-720-2-1/2 | 2 1/2 | 1/2 | 2 1/8 | 5 3/8 | 1/4 X 1 1/4 | 1/2-1 1/4 | 700 | 10 |
| S-720-3 | 3 | 1/2 | 2 1/4 | 6 1/4 | 1/4 X 1 1/4 | 1/2-1 1/4 | 1,100 | 10 |
| S-720-3-1/2 | 3 1/2 | 1/2 | 2 1/4 | 6 3/4 | 1/4 X 1 1/4 | 1/2-1 1/4 | 1,100 | 10 |
| S-720-4 | 4 | 1/2 | 2 1/4 | 7 1/4 | 1/4 X 1 1/4 | 1/2-1 1/4 | 1,300 | 10 |
| S-720-5 | 5 | 5/8 | 2 1/4 | 8 1/2 | 1/4 X 1 1/2 | 5/8-1 1/2 | 1,600 | 10 |
| S-720-6 | 6 | 5/8 | 2 1/4 | 9 1/2 | 1/4 X 1 1/2 | 5/8-1 1/2 | 1,600 | 5 |
| S-720-8 | 8 | 3/4 | 2 1/8 | 11 1/2 | 1/4 X 2 | 3/4-2 | 2,000 | 5 |

Standard Finish – GoldGalv®, unless otherwise stated.

Pipe Straps, Conduit Clamps and Hangers

PG-794 — Pipe Alignment Guide

Designed to maintain the axial alignment of piping as it expands and contracts during operation. It is most typically installed adjacent to expansion joints and at reasonable distances between the expansion joint and the anchor point. Our Figures 1007 and 1010 also offer alternative means for your piping alignment needs.

Note: Guides are not designed to carry dead weight loads. Maximum temperature is 750° F.

Specifications

- Material: Carbon Steel
 - Finish: EG (Silver), Black (add suffix "-B"), Electro-Galvanized (add suffix "-EG")
 - Ordering: Specify pipe size, insulation thickness, catalog number and finish.
- Example Catalog Number:** PG794 T3-2-1/2 would be 2 1/2" pipe with 2" thick insulation.

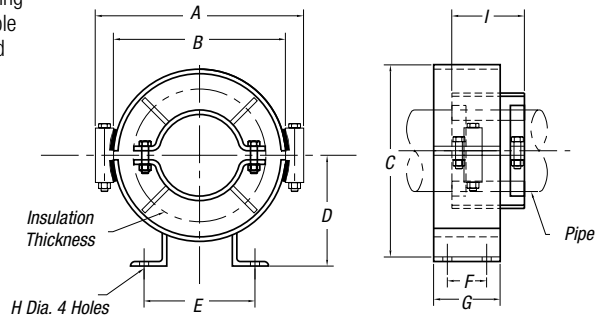

M-718

| SIZE | DIMENSIONS (IN.) | | | | | | | | | WT. EACH (LBS.) |
|------|------------------|--------|--------|--------|--------|-------|---|-----|-------|-----------------|
| | A | B | C | D | E | F | G | H | | |
| 1 | 6 3/4 | 4 1/2 | 5 5/8 | 3 3/8 | 5 | 1 1/2 | 3 | 5/8 | 5.8 | |
| 2 | 7 1/4 | 5 5/8 | 6 3/8 | 3 1/2 | 6 3/4 | 1 1/2 | 3 | 5/8 | 7.2 | |
| 3 | 8 3/8 | 6 3/8 | 7 3/8 | 4 | 6 3/4 | 1 1/2 | 3 | 5/8 | 8.2 | |
| 4 | 10 5/8 | 8 3/8 | 9 3/8 | 5 | 7 3/8 | 1 1/2 | 3 | 5/8 | 10.6 | |
| 5 | 12 1/2 | 10 3/4 | 11 3/8 | 6 1/4 | 7 3/8 | 2 | 4 | 5/8 | 15.6 | |
| 6 | 14 3/8 | 12 3/4 | 13 3/8 | 7 1/4 | 8 | 2 | 4 | 5/8 | 19.5 | |
| 7 | 16 3/8 | 14 3/4 | 15 3/8 | 8 1/2 | 9 3/4 | 2 | 4 | 3/4 | 26.8 | |
| 8 | 18 3/8 | 16 3/4 | 17 3/8 | 9 1/2 | 10 1/4 | 4 | 6 | 3/4 | 35.6 | |
| 9 | 22 3/8 | 19 | 20 | 10 1/2 | 11 1/4 | 4 | 6 | 3/4 | 44.2 | |
| 10 | 23 3/8 | 21 | 22 | 11 1/2 | 14 3/8 | 4 | 6 | 7/8 | 52.6 | |
| 11 | 25 3/8 | 23 | 24 | 12 1/2 | 14 3/4 | 4 | 6 | 7/8 | 66.3 | |
| 12 | 28 3/8 | 25 3/4 | 26 3/8 | 13 3/4 | 15 3/8 | 4 | 6 | 1 | 79.7 | |
| 13 | 32 3/8 | 29 1/2 | 30 1/2 | 15 3/4 | 16 3/8 | 5 1/2 | 8 | 1 | 106.3 | |
| 14 | 36 3/8 | 33 1/2 | 34 1/2 | 17 3/4 | 17 3/8 | 5 1/2 | 8 | 1 | 116.8 | |

| SIZE NUMBER | THICKNESS OF INSULATION (IN.) | | | | | |
|-------------|-------------------------------|-------------|-------------|-------------|-------------|-------------|
| | 1 | 1 1/2 | 2 | 2 1/2 | 3 | 4 |
| 1 | 1 | | | | | |
| 2 | 1 1/4-2 | 1 | | | | |
| 3 | 2 1/2 | 1 1/4-2 | 1 | | | |
| 4 | 3-4 | 2 1/2-3 1/2 | 1 1/4-2 1/2 | 1-2 | 1 | |
| 5 | 5-6 | 4-5 | 3-4 | 2 1/2-3 1/2 | 1 1/4-2 1/2 | 1 |
| 6 | | 6 | 5-6 | 4-5 | 3-4 | 1 1/4-2 1/2 |
| 7 | | 8 | 8 | 6 | 5-6 | 3-4 |
| 8 | | 10 | 10 | 8 | 8 | 5-6 |
| 9 | | 12 | 12 | 10 | 10 | 8 |
| 10 | | | 14 | 12-14 | 12 | 10 |
| 11 | | | | 16 | 16 | 14 |
| 12 | | | | | | 16-18 |
| 13 | | | | | | 20 |
| 14 | | | | | | 24 |

Standard Finish — EG (silver).

| PIPE SIZE (IN.) | DIM. I | MAX. MVT |
|-----------------|--------|----------|
| 1-6 | 4 | 4 |
| 8-16 | 6 | 6 |
| 18-24 | 8 | 8 |

Insulation Thickness Table

| PRODUCT DESIGNATION | INSULATION THICKNESS (IN.) | FOR PIPE SIZES |
|---------------------|----------------------------|----------------|
| T1 | 1 | 1/2-24 |
| T2 | 1 1/2 | 1/2-24 |
| T3 | 2 | 1/2-24 |
| T4 | 2 1/2 | 1/2-24 |
| T5 | 3 | 1/2-24 |
| T6 | 3 1/2 | 1/2-24 |
| T7 | 4 | 1/2-24 |

Standard Finish — GoldGalv®, unless otherwise stated.

Pipe Straps, Conduit Clamps and Hangers

Structure Attachments

M-742-R Ceiling Flange

M-742-R, M-742-RB, MT-742-R – Single Plate

M-742-R — (Rod Tapped – Electro-Galvanized)

M-742-RB — (Rod Tapped – Plain Finish)

MT-742-R — (Rod Tapped – Copper Finish)

Designed for attaching a rod to a wooden member.

This part is normally used in conjunction with our M-718 Split Ring.

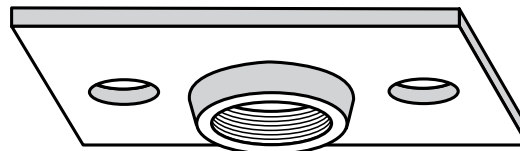
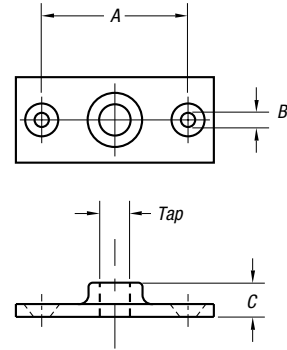

M-742-R
Rod Sizes: 3/8" & 1/2"

Specifications

- Material: Malleable Iron. M-742-R is Carbon Steel.
- Ordering: Specify rod size and catalog number.

| CAT. NO. | ROD TAP (IN.) | MAX. LOAD (LBS.) | DIMENSIONS (IN.) | | | WT. EACH (LBS.) |
|-------------|---------------|------------------|------------------|-----|-----|-----------------|
| | | | A | B | C | |
| M-742-R-3/8 | 3/8 | 180 | 2 | 1/4 | 1/2 | .19 |
| M-742-R-1/2 | 1/2 | 180 | 2 | 1/4 | 1/2 | .18 |

Standard Finish – Black (B), EG (Silver) or Copper-Colored Epoxy Paint.

C-736-Side Clip — Steel Bracket Clip

Clip can be used to support piping 3 1/2" or smaller from the horizontal member of a C-736 Steel Bracket. The clip is composed of two steel plates and one bolt and nut.

Specifications

- Material: Carbon Steel
- Finish: Standard Finish – GoldGalv®, Black (add suffix "-B"), Electro-Galvanized (add suffix "-EG")
- Ordering: Specify size number, catalog number and finish.

| CAT. NO. | ROD SIZE (IN.) | SIZE (IN.) | MAX. LOAD (LBS.) | WT. EACH (LBS.) |
|-------------------|----------------|------------|------------------|-----------------|
| C-736-SIDE CLIP-1 | 1 | 3/8 | 750 | 6.99 |
| C-736-SIDE CLIP-2 | 2 | 1/2 | 750 | 10.10 |

Standard Finish – GoldGalv®, unless otherwise stated.

Pipe Straps, Conduit Clamps and Hangers

C-736 — Light Welded Steel Bracket

Designed to support up to 6" pipe. This bracket is for installation to walls as shown or inverted, and may require a backing plate. Holes for up to 3/4" rods are located at each end of the bracket to allow for use in either orientation. The C-736 Side Clip Steel Bracket Clip can be attached to the C-736 to support piping 3 1/2" or smaller. Please see Figure 79 for more information.

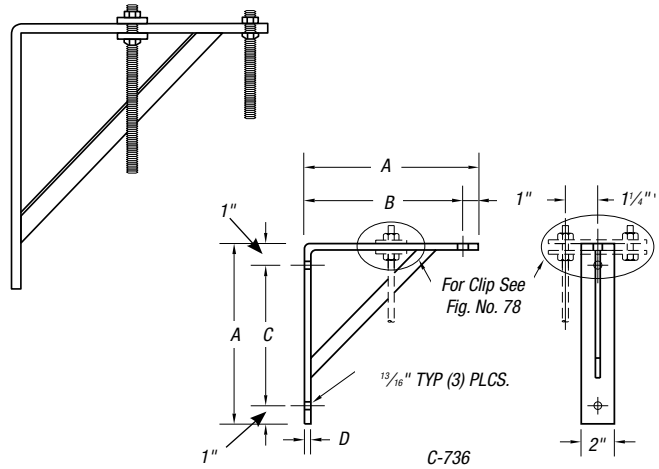

Specifications

- Compliance: A-A-1192A Type 31, MSS-SP 69 Type 31
- Finish: Standard Finish – GoldGalv®, Black (add suffix "-B"), Electro-Galvanized (add suffix "-EG")
- Ordering: Specify size number, catalog number and finish.

| CAT. NO. | ROD TAP | MAX. LOAD (LBS.) | DIMENSIONS (IN.) | | | WT. EACH (LBS.) |
|----------|---------|------------------|------------------|----|--------|-----------------|
| | | | A | B | C | |
| C-736-1 | 1 | 750 | 9 | 8 | 6 1/2 | 6.99 |
| C-736-2 | 2 | 750 | 13 | 12 | 10 1/2 | 10.10 |
| C-736-3 | 3 | 750 | 19 | 18 | 16 1/2 | 10.50 |

Standard Finish – GoldGalv®, unless otherwise stated.

C-739-H — Heavy Welded Steel Bracket

Designed to support pipe from either above or below. Slotted construction allows for drop rod use along the length of the bracket. This bracket is for bolted installation to walls and may require a backing plate. Special steel brackets can be fabricated to customers loads and/or dimensions.

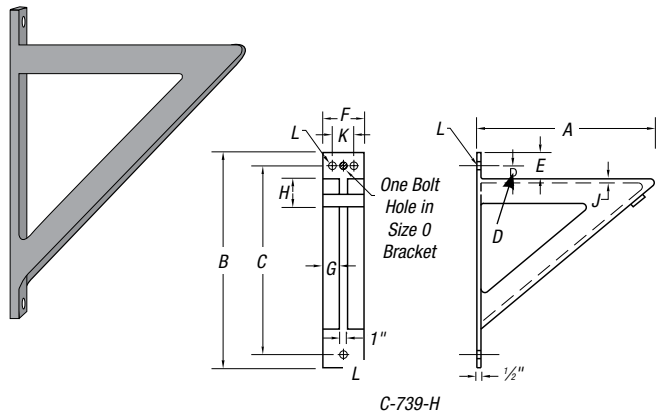

Specifications

- Compliance: A-A-1192A Type 33, MSS-SP 69 Type 33
- Finish: Standard Finish – GoldGalv®, Black (add suffix "-B"), Electro-Galvanized (add suffix "-EG")
- Ordering: Specify size number, catalog number and finish.

| CAT. NO. | SIZE | MAX. LOAD (LBS.) | DIMENSIONS (IN.) | | | | | | | | | | WT. EACH (LBS.) | |
|-----------|------|------------------|------------------|----|--------|-------|-------|-------|-------|-------|-----|-------|-----------------|-------|
| | | | A | B | C | D | E | F | G | H | J | K | | L |
| C-739-H-0 | 0 | 3,000 | 12 | 18 | 15 1/4 | 1 1/2 | 2 3/4 | 4 1/2 | 1 1/2 | 2 | 1/4 | NA | 1 3/16 | 25.1 |
| C-739-H-1 | 1 | 3,000 | 18 | 24 | 21 3/4 | 1 1/2 | 2 3/4 | 5 | 1 1/2 | 2 | 3/8 | 2 3/4 | 1 3/16 | 44.8 |
| C-739-H-2 | 2 | 3,000 | 24 | 30 | 27 1/2 | 1 1/2 | 2 3/4 | 5 | 1 1/2 | 2 1/2 | 3/8 | 2 1/2 | 1 1/16 | 60.7 |
| C-739-H-3 | 3 | 3,000 | 30 | 36 | 33 1/4 | 1 5/8 | 3 | 6 | 2 | 2 1/2 | 3/8 | 2 1/2 | 1 1/16 | 98.1 |
| C-739-H-4 | 4 | 3,000 | 36 | 42 | 39 | 1 1/2 | 3 | 6 | 2 | 3 1/2 | 3/8 | 3 1/2 | 1 1/16 | 129.4 |
| C-739-H-5 | 5 | 3,000 | 42 | 50 | 46 | 1 1/2 | 3 1/2 | 7 | 2 1/2 | 3 1/2 | 3/8 | 3 1/2 | 1 1/16 | 177.2 |

Pipe Straps, Conduit Clamps and Hangers

PG-795 — Pipe Block

Standard Finish — Black (B).

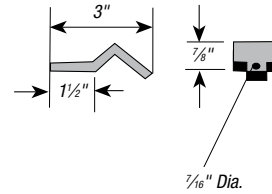
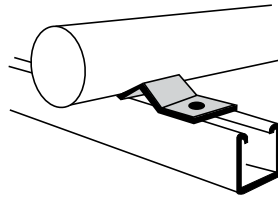

Pipe Attachments

H-115, H-115SS — Standard U-Bolt

Our standard U-Bolts are recommended for use as supports or guides for piping. They are supplied with four hex nuts. The H-115SS is recommended for support of stainless steel piping. Please specify the grade of stainless steel you require when ordering. Load Ratings shown are for Carbon Steel. PVC coating should not exceed 140° F/60° C.

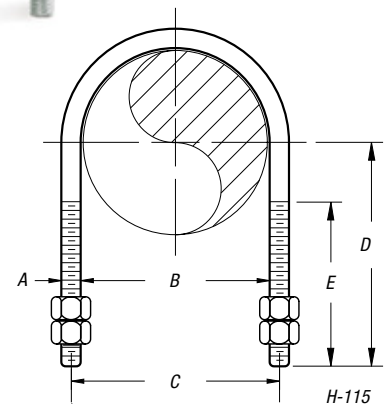

Specifications

- Materials: Carbon Steel, Stainless Steel
 - Compliance: Federal Specification A-A-1192A Type 24, MSS-SP 69 Type 24, and BSPSS-BS3974
 - Finish: Standard Finish — GoldGalv®, Black (add suffix “-B”), Electro-Galvanized (add suffix “-EG”), SS (add suffix SS), SS6 = 316
- Side loads are given for the H-115 for a maximum temperature of 650° F/343° C.

When the loading condition requires the simultaneous application of a normal load and side load, the following interaction equation must be used to determine if the H-115 can be used.

(Actual Load / Maximum Design Load) + (Actual Side Load/Maximum Side Load). The result of this equation cannot exceed the value of 1.0 if the H-115 is to be used.

- Ordering: Specify pipe size, catalog number and finish.

| CAT. NO. | PIPE SIZE (IN.) | MAX. LOAD (LBS.) | | MAX. SIDE LOAD (LBS.) 650° F/343° C | DIMENSIONS (IN.) | | | | | WT. EACH (LBS.) |
|-------------|-----------------|-------------------|-------------------|--|------------------|-------|-------|-------|-------|-----------------|
| | | 650° F/ 343° C | 750° F/ 399° C | | A | B | C | D | E | |
| H-115-1/2 | 1/2 | 485 | 435 | 63 | 1/4 | 1 1/8 | 1 1/8 | 2 3/4 | 2 1/8 | .11 |
| H-115-3/4 | 3/4 | 485 | 435 | 63 | 1/4 | 1 1/8 | 1 1/8 | 2 3/4 | 2 1/8 | .12 |
| H-115-1 | 1 | 485 | 435 | 63 | 1/4 | 1 3/8 | 1 3/8 | 2 3/4 | 2 1/8 | .12 |
| H-115-1/2 | 1/2 | 1,200 | 1,070 | 316 | 3/8 | 1 3/8 | 1 1/4 | 2 3/4 | 2 1/8 | .16 |
| H-115-3/4 | 3/4 | 1,200 | 1,070 | 240 | 3/8 | 1 1/8 | 1 1/2 | 2 3/4 | 2 1/8 | .16 |
| H-115-1 | 1 | 1,200 | 1,070 | 186 | 3/8 | 1 3/8 | 1 3/4 | 2 3/4 | 2 1/8 | .19 |
| H-115-1-1/4 | 1 1/4 | 1,220 | 1,090 | 194 | 3/8 | 1 3/4 | 2 1/8 | 2 7/8 | 2 1/8 | .28 |
| H-115-1-1/2 | 1 1/2 | 1,220 | 1,090 | 194 | 3/8 | 2 | 2 3/8 | 3 | 2 1/2 | .30 |
| H-115-2 | 2 | 1,220 | 1,090 | 194 | 3/8 | 2 1/2 | 2 3/8 | 3 1/4 | 2 1/2 | .33 |
| H-115-2-1/2 | 2 1/2 | 2,260 | 2,020 | 184 | 1/2 | 3 | 3 1/2 | 3 3/4 | 3 | .70 |
| H-115-3 | 3 | 2,260 | 2,020 | 184 | 1/2 | 3 3/8 | 4 1/8 | 4 | 3 | .78 |
| H-115-3-1/2 | 3 1/2 | 2,260 | 2,020 | 184 | 1/2 | 4 1/8 | 4 3/8 | 4 1/2 | 3 | .84 |
| H-115-4 | 4 | 2,260 | 2,020 | 184 | 1/2 | 4 3/8 | 5 1/8 | 4 1/2 | 3 | .90 |

Pipe Straps, Conduit Clamps and Hangers

Beam Attachments

M-750 — Side Beam Bracket

Designed for bolt connections.

Specifications

- Compliance: A-A-1192A Type 34 and MSS-SP 69 Type 34
- Material: Malleable Iron (Maximum Temperature 450° F/232° C)
- Standard Finish – GoldGalv®, Black (add suffix “-B”), Electro-Galvanized (add suffix “-EG”)
- Ordering: Specify rod size and catalog number.

| CAT. NO. | MAX LOAD (LBS.) | | WITH BOLT TO STEEL | DIMENSIONS (IN.) | | | | WT. EACH (LBS.) |
|-----------|-----------------|----------------|--------------------|------------------|--------|------|--------|-----------------|
| | ROD SIZE (IN.) | WITH LAG SCREW | | C | D | F | G | |
| M-750-3/8 | 3/8 | 390 | 610 | 5/8 | 1 1/16 | 7/16 | 7/8 | .26 |
| M-750-1/2 | 1/2 | 640 | 1,130 | 3/4 | 1 3/8 | 9/16 | 1 1/16 | .54 |
| M-750-5/8 | 5/8 | 760 | 1,810 | 7/8 | 2 1/8 | 3/4 | 1 1/16 | .94 |

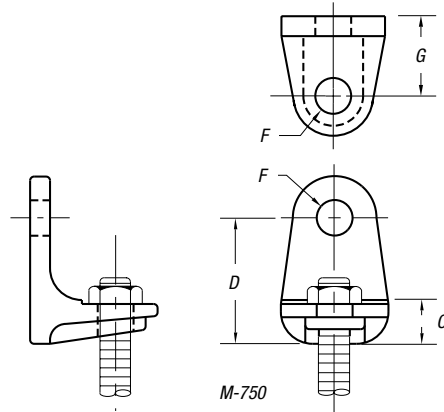

M-762 — Side Beam Connector

Designed for use on buildings of wood construction. They can be secured to the side of beams or joists by means of our Figure 166 Drive Screws (ordered separately).

Specifications

- Material: Malleable Iron
- Standard Finish – GoldGalv®, Black (add suffix “-B”), Electro-Galvanized (add suffix “-EG”)
- Ordering: Specify size, catalog number and finish.

| CAT. NO. | SIZE (IN.) | MAX LOAD (LBS.) | DIMENSIONS (IN.) | | | WT. EACH (LBS.) |
|-----------|------------|-----------------|------------------|-----|-----|-----------------|
| | | | A | B | C | |
| M-762-3/8 | 3/8 rod | 250 | 2 3/8 | 3/4 | 3/4 | .13 |
| M-762-1/2 | 1/2 rod | 480 | 2 3/4 | 3/4 | 3/4 | .25 |
| M-762-1/4 | 1/4 pipe | 250 | 2 3/4 | 3/4 | 3/4 | .25 |

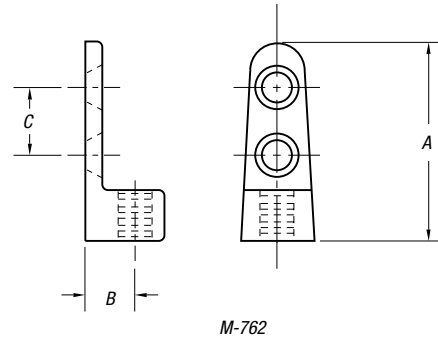

C-747 — Adjustable Beam Attachment

For attachment to timber with coach screws or to the bottom of beams with bolts.

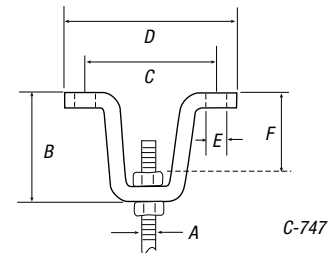

| CAT. NO. | ROD SIZE A (IN.) | HOLE SIZE (IN.) | DIMENSIONS (IN.) | | | | | STOCK SIZE (IN.) | DESIGN LOAD (LBS.) | STD. CTN. |
|------------|------------------|-----------------|------------------|-------|-------|--------|--------|------------------|--------------------|-----------|
| | | | B | C | D | E | F | | | |
| C-747-3/8B | 3/8B | 7/16 | 2 3/4 | 3 3/8 | 4 7/8 | 7/16 | 2 1/8 | 1/4 x 1 1/4 | 610 | 50 |
| C-747-1/2B | 1/2B | 9/16 | 3 1/8 | 4 3/4 | 6 | 9/16 | 2 5/16 | 3/8 x 1 1/2 | 1,130 | 50 |
| C-747-5/8B | 5/8B | 1 1/16 | 3 3/8 | 4 3/4 | 6 | 9/16 | 2 3/16 | 3/8 x 1 1/2 | 1,810 | 50 |
| C-747-3/4B | 3/4B | 1 3/16 | 3 11/16 | 6 1/4 | 7 3/4 | 1 1/16 | 2 9/16 | 1/2 x 2 | 2,710 | 50 |
| C-747-7/8B | 7/8B | 1 5/16 | 3 3/4 | 6 3/8 | 8 1/4 | 1 3/16 | 2 1/2 | 1/2 x 2 | 3,770 | 50 |

Standard Finish — Black (B).

Order by Cat. No., rod size.

Pipe Straps, Conduit Clamps and Hangers

Rods and Rod Attachments

F-112 — Turnbuckle

Used to connect right- and left-hand threaded rods together and provide for adjustment.

Specifications

- Material: Forged Steel
- Compliance: Federal Specification A-A-1192A Type 13, MSS-SP 69 Type 13 and BSPSS-BS3974
- Finish: Standard Finish – GoldGalv®, Black (add suffix “-B”), Electro-Galvanized (add suffix “-EG”)
- Specify catalog number, finish and rod size.

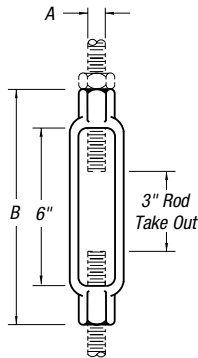

F-112

| CAT. NO. | ROD SIZE (IN.) | MAX LOAD (LBS.) | | B (IN.) | WT. EACH (LBS.) |
|-------------|----------------|-----------------|--|---------|-----------------|
| | | 650° F/343° C | | | |
| F-112-3/8 | 3/8 | 610 | | 7 1/8 | .30 |
| F-112-1/2 | 1/2 | 1,130 | | 7 1/2 | .60 |
| F-112-5/8 | 5/8 | 1,810 | | 7 7/8 | 1.00 |
| F-112-3/4 | 3/4 | 2,710 | | 8 1/4 | 1.20 |
| F-112-7/8 | 7/8 | 3,370 | | 8 5/8 | 1.90 |
| F-112-1 | 1 | 4,960 | | 9 | 2.50 |
| F-112-1-1/4 | 1 1/4 | 8,000 | | 9 1/2 | 3.80 |
| F-112-1-1/2 | 1 1/2 | 11,630 | | 9 3/4 | 5.70 |
| F-112-1-3/4 | 1 3/4 | 15,700 | | 10 5/8 | 8.20 |
| F-112-2 | 2 | 20,700 | | 11 | 14.20 |
| F-112-2-1/4 | 2 1/4 | 27,200 | | 12 5/8 | 27.00 |
| F-112-2-1/2 | 2 1/2 | 33,500 | | 13 1/2 | 33.00 |

Standard Finish – GoldGalv®, unless otherwise stated.

M-129 — Extension Piece

Designed for attaching rods to the M-732-EXT Clamp and similar types of attachments.

Specifications

- Material: Malleable Iron
- Compliance: Federal Specification A-A-1192A Type 30, MSS-SP-69 Type 30 when used with a Figure 82
- Finish: Standard Finish – GoldGalv®, Black (add suffix “-B”), Electro-Galvanized (add suffix “-EG”)
- Specify rod size, catalog number and finish

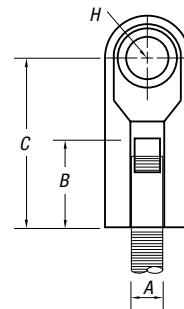

M-129

| CAT. NO. | ROD SIZE (IN.) | MAX LOAD (LBS.) | DIMENSIONS (IN.) | | | | WT. EACH (LBS.) |
|-----------|----------------|-----------------|------------------|-------|-----|------|-----------------|
| | | | B | C | G | H | |
| M-129-3/8 | 3/8 | 610 | 1 1/4 | 2 1/8 | 1/2 | 1/2 | .20 |
| M-129-1/2 | 1/2 | 1,130 | 1 3/8 | 2 3/8 | 5/8 | 1/2 | .40 |
| M-129-5/8 | 5/8 | 1,810 | 1 1/2 | 2 1/2 | 5/8 | 1/2 | .44 |
| M-129-3/4 | 3/4 | 2,710 | 1 3/4 | 2 7/8 | 5/8 | 1/2 | .65 |
| M-129-7/8 | 7/8 | 2,950 | 1 7/8 | 3 | 3/4 | 9/16 | .78 |

Standard Finish – GoldGalv®, unless otherwise stated.

Pipe Straps, Conduit Clamps and Hangers

Structure Attachments

C-780 W/OB, C-780 W/HWB — Welded Beam Attachment

Recommended for attachment to the bottom of beams when little or no pipe movement is expected. C-780 W/HWB is recommended for attachment to the bottom of beams, when pipe movement is expected. A bolt and nut or pin is supplied. A pin with cotters is normally supplied for rod sizes over 1".

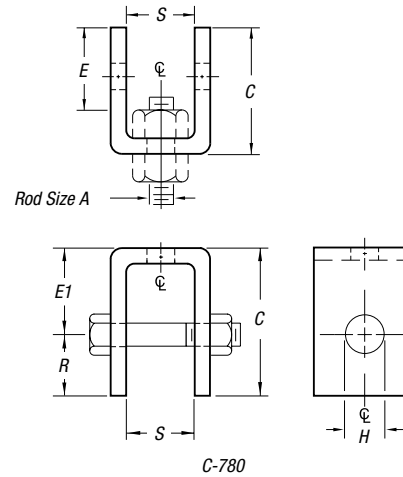

- Specifications**
- Compliance: Federal Specification A-A-1192A Type 22, MSS SP-69 Type 22 and BSPSS-BS3974
 - Material: Carbon Steel
 - Finish: Standard Finish – GoldGalv®, Black (add suffix “-B”), Electro-Galvanized (add suffix “-EG”)
 - Ordering: Specify catalog number, rod size and finish.

| CAT. NO. | ROD SIZE (IN.) | MAX. LOAD (LBS.) 650° F/ 343° C | BOLT OR PIN SIZE (IN.) | C (IN.) | ROD TAKEOUT | ROD TAKEOUT | H (IN.) | R (IN.) | S (IN.) | WT. EACH (LBS.) | |
|-------------|----------------|---------------------------------------|------------------------|---------|--------------------|----------------------|---------|---------|---------|--------------------|-------------------|
| | | | | | C-780 W/OB E (IN.) | C-780 W/HWB E1 (IN.) | | | | C-780 W/OB W/O B&N | C-780 W/HWB W B&N |
| C-780-3/8 | 3/8 | 610 | 1/2 | 2 7/8 | 1 7/8 | 2 | 9/16 | 7/8 | 1 1/4 | .96 | 1.20 |
| C-780-1/2 | 1/2 | 1,130 | 5/8 | 2 7/8 | 1 3/4 | 2 | 1 1/16 | 7/8 | 1 1/4 | .96 | 1.20 |
| C-780-5/8 | 5/8 | 1,810 | 3/4 | 2 7/8 | 1 3/4 | 2 | 1 3/16 | 7/8 | 1 1/4 | .96 | 1.60 |
| C-780-3/4 | 3/4 | 2,710 | 7/8 | 3 3/8 | 1 1/2 | 2 | 1 15/16 | 1 1/8 | 2 1/8 | 1.90 | 2.80 |
| C-780-7/8 | 7/8 | 3,770 | 1 | 4 1/4 | 2 5/8 | 3 | 1 1/8 | 1 1/4 | 2 1/8 | 2.50 | 3.90 |
| C-780-1 | 1 | 4,960 | 1 1/8 | 4 1/2 | 3 | 3 1/2 | 1 1/4 | 1 1/2 | 2 3/8 | 4.30 | 6.30 |
| C-780-1-1/4 | 1 1/4 | 8,000 | 1 3/8 | 5 | 2 | 3 | 1 1/2 | 2 | 3 | 8.10 | 10.20 |
| C-780-1-1/2 | 1 1/2 | 11,600 | 1 5/8 | 5 1/2 | 2 1/2 | 4 | 1 3/4 | 2 1/2 | 3 | 15.60 | 19.00 |
| C-780-1-3/4 | 1 3/4 | 15,700 | 1 7/8 | 7 3/4 | 2 3/4 | 5 | 2 | 2 3/4 | 3 3/4 | 18.70 | 24.20 |
| C-780-2 | 2 | 20,700 | 2 1/4 | 8 1/4 | N/A | 5 | 2 3/8 | 3 1/4 | 3 3/4 | — | 30.60 |
| C-780-2-1/4 | 2 1/4 | 27,200 | 2 1/2 | 9 3/4 | N/A | 6 1/4 | 2 5/8 | 3 1/2 | 3 3/4 | — | 36.80 |
| C-780-2-1/2 | 2 1/2 | 33,500 | 2 3/4 | 9 3/4 | N/A | 6 3/4 | 2 7/8 | 3 3/4 | 3 3/4 | — | 39.70 |
| C-780-2-3/4 | 2 3/4 | 41,580 | 3 | 9 3/4 | N/A | 5 3/4 | 3 1/8 | 4 | 3 3/4 | — | 39.70 |
| C-780-3 | 3 | 50,580 | 3 1/4 | 10 1/4 | N/A | 6 1/4 | 3 3/8 | 4 | 3 3/4 | — | 49.00 |
| C-780-3-1/4 | 3 1/4 | 71,280 | 3 1/2 | 11 1/2 | N/A | 7 | 3 7/8 | 4 1/2 | 4 1/4 | — | 67.60 |
| C-780-3-1/2 | 3 1/2 | 71,280 | 3 3/4 | 12 | N/A | 7 1/2 | 3 7/8 | 4 1/2 | 4 1/4 | — | 79.30 |

Pipe Straps, Conduit Clamps and Hangers

C-755 — Beam Clamp

Designed to attach to the bottom of flanged beams. Normally used with the E-157 Eye Rod or E-120-A Eye Nut.

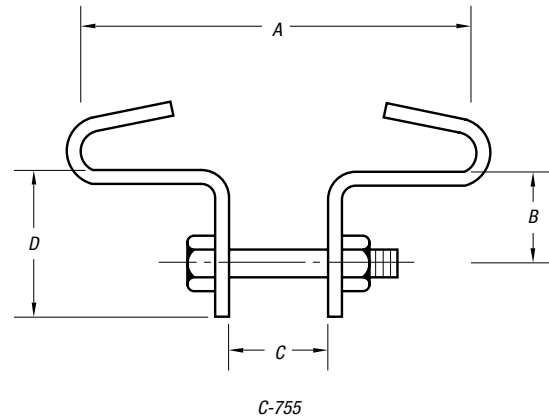

Specifications

- Material: Carbon Steel
- Compliance: Federal Specification A-A-1192A Type 21, MSS-SP-69 Type 21
- Finish: Standard Finish – GoldGalv®, Black (add suffix “-B”), Electro-Galvanized (add suffix “-EG”), Thermoplastic (add suffix “-TP”)
- Ordering: Specify clamp size, flange width, flange thickness, catalog number and finish.

| CAT. NO. | CLAMP SIZE | MAX. LOAD (LBS.) | DIMENSIONS (IN.) | | | BOLT SIZE (IN.) |
|----------|------------|------------------|------------------|-------|-------|-----------------|
| | | | B | C | D | |
| C-755-1 | 1 | 500 | 7/8 | 1/2 | 1 1/2 | 3/8 |
| C-755-2 | 2 | 700 | 1 1/8 | 5/8 | 1 3/4 | 1/2 |
| C-755-3 | 3 | 800 | 1 1/4 | 5/8 | 2 | 1/2 |
| C-755-4 | 4 | 1,000 | 1 3/8 | 3/4 | 2 3/8 | 5/8 |
| C-755-5 | 5 | 3,000 | 1 7/8 | 7/8 | 2 7/8 | 3/4 |
| C-755-6 | 6 | 3,000 | 2 | 1 | 3 | 7/8 |
| C-755-7 | 7 | 5,000 | 2 1/8 | 1 1/8 | 4 1/8 | 1 |

| CAT. NO. | CLAMP SIZE | WEIGHT EACH (LBS.) BEAM WIDTH — DIMENSION “A” | | | | | | | |
|----------|------------|--|------|------|-------|-------|-------|-------|-------|
| | | 2 | 3 | 4 | 5 | 6 | 7 | 8 | 10 |
| C-755-1 | 1 | .52 | .62 | .78 | .88 | .95 | — | — | — |
| C-755-2 | 2 | .74 | .82 | 1.09 | 1.21 | 1.31 | 1.39 | — | — |
| C-755-3 | 3 | 1.26 | 1.49 | 1.89 | 2.12 | 2.29 | 2.45 | 2.69 | — |
| C-755-4 | 4 | — | 2.32 | 2.85 | 3.18 | 3.39 | 3.60 | 3.92 | — |
| C-755-5 | 5 | — | 3.40 | 4.08 | 4.52 | 4.80 | 5.10 | 5.51 | 6.23 |
| C-755-6 | 6 | — | — | 6.00 | 6.45 | 7.00 | 7.40 | 7.90 | 8.80 |
| C-755-7 | 7 | — | — | — | 11.95 | 12.75 | 13.55 | 14.35 | 15.95 |

Pipe Straps, Conduit Clamps and Hangers

M-732-H — Steel Beam Clamp with Weldless Eyenut

The M-732-H beam clamp with eyenut is used for support where some movement is expected and welding to the structure is prohibited. The clamping effect is produced by the "ice-tong" action of the arms and is locked in place by the through bolt located just under the beam flange.

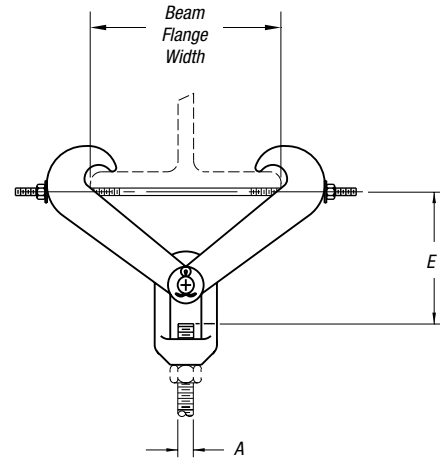

M-732-H

Specifications

- Material: Carbon Steel with Forged Steel Eyenut
- Compliance: Federal Specification A-A-1192A Type 28, MSS-SP-69 Type 28 and BSPSS-BS3974
- Finish: Standard Finish – GoldGalv®, Black (add suffix "-B"), Electro-Galvanized (add suffix "-EG")
- Ordering: Specify catalog number, rod size, clamp number and finish.

| CAT. NO. | CLAMP SIZE | MAX. LOAD (LBS.) | MAX. ROD SIZE A (IN.) | BEAM WIDTH | BODY SIZE (IN.) | MAX. FLANGE THICKNESS (IN.) | WT. EACH (LBS.) |
|-----------|------------|------------------|-----------------------|------------|-----------------|-----------------------------|-----------------|
| M-732-H-1 | 1 | 2,710 | 3/4 | 3-8 | 25/32 | .6 | 5.5 |
| M-732-H-2 | 2 | 4,960 | 1 | 3-8 | 25/32 | .6 | 5.5 |
| M-732-H-3 | 3 | 4,960 | 1 | 4-11 | 27/32 | .6 | 9.0 |
| M-732-H-4 | 4 | 4,960 | 1 | 4-12 | 29/32 | 1.03 | 29.0 |
| M-732-H-5 | 5 | 4,960 | 1 | 11-15 | 1/64 | 1.03 | 33.3 |
| M-732-H-6 | 6 | 11,500 | 1 1/2 | 4-12 | 29/32 | 1.03 | 29.0 |
| M-732-H-7 | 7 | 11,500 | 1 1/2 | 11-15 | 1/64 | 1.03 | 33.3 |
| M-732-H-8 | 8 | 11,500 | 2 | 4-12 | 29/32 | 1.03 | 29.0 |

| CAT. NO. | CLAMP SIZE | BODY SIZE (IN.) | DIMENSIONS (IN.) | | | | | | | | | | | | | | |
|-----------|------------|-----------------|------------------|--------|--------|---------|--------|---------|--------|--------|--------|-------|-------|-------|-------|--|--|
| | | | 3 | 4 | 5 | 6 | 7 | 8 | 9 | 10 | 11 | 12 | 13 | 14 | 15 | | |
| M-732-H-1 | 1 | 25/32 | 5 5/16 | 5 1/8 | 5 | 4 13/16 | 4 3/8 | 3 15/16 | — | — | — | — | — | — | — | | |
| M-732-H-2 | 2 | 25/32 | 5 5/16 | 5 1/8 | 5 | 4 13/16 | 4 3/8 | 3 15/16 | — | — | — | — | — | — | — | | |
| M-732-H-3 | 3 | 27/32 | — | 8 1/4 | 8 1/8 | 8 1/8 | 7 7/8 | 7 7/8 | 7 3/8 | 7 | 6 1/2 | — | — | — | — | | |
| M-732-H-4 | 4 | 27/32 | — | 8 5/8 | 8 5/8 | 8 1/2 | 8 3/8 | 8 3/8 | 7 7/8 | 7 3/8 | 7 | 6 3/8 | — | — | — | | |
| M-732-H-5 | 5 | 1/64 | — | — | — | — | — | — | — | — | 9 1/2 | 9 1/4 | 8 3/8 | 8 3/8 | 7 7/8 | | |
| M-732-H-6 | 6 | 3/8 | — | 8 3/8 | 8 3/8 | 8 1/2 | 8 3/8 | 8 3/8 | 7 7/8 | 7 3/8 | 7 | 6 3/8 | — | — | — | | |
| M-732-H-7 | 7 | 1/64 | — | — | — | — | — | — | — | — | 9 5/8 | 9 1/2 | 9 1/8 | 8 3/8 | 8 3/8 | | |
| M-732-H-8 | 8 | 3/8 | — | 11 5/8 | 11 1/2 | 11 1/2 | 11 3/8 | 11 3/8 | 10 7/8 | 10 7/8 | 10 1/2 | 10 | — | — | — | | |

Pipe Straps, Conduit Clamps and Hangers

M-732-EXT — Adjustable Beam Clamp

Designed to attach to the bottom of flanged beams without requiring welding. Normally used with the M-129 Extension Piece (not furnished) up to a maximum 7/8" (M20) rod diameter. Loading is achieved through the clamp jaws while locking is accomplished by tightening the through-bolt located directly below the flange. Maximum flange thickness is .60 inches.

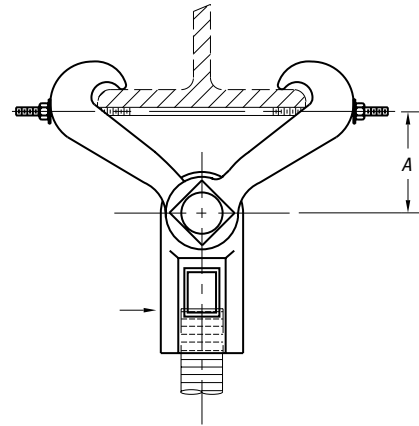

M-732-EXT

Specifications

- Material: Malleable Iron
- Compliance: Federal Specification A-A-1192A Type 30, MSS-SP-69 Type 30 when used with a Figure 157
- Finish: Standard Finish – GoldGalv®, Black (add suffix “-B”), Electro-Galvanized (add suffix “-EG”)
- Ordering: Specify catalog number and finish. Order M-129 separately if required.

| CAT. NO. | MAX. ROD SIZE (IN.) | MAX. LOAD (LBS.) | ROD TAKE OUT BEAM FLANGE WIDTH — B (IN.) | | | | | | WT. EACH (LBS.) |
|---------------|---------------------|------------------|---|---------|----------|----------|----------|----------|-----------------|
| | | | 2C 60 | 3 76 | 4 101 | 5 127 | 6 152 | 7 177 | |
| M-732-EXT-3/8 | 3/8 | 610 | 3 1/2 | 3 7/16 | 3 5/16 | 2 15/16 | 2 9/16 | 1 7/8 | 1.91 |
| M-732-EXT-1/2 | 1/2 | 1,130 | 3 1/2 | 3 7/16 | 3 5/16 | 2 15/16 | 2 9/16 | 1 7/8 | 2.11 |
| M-732-EXT-5/8 | 5/8 | 1,365 | 3 1/2 | 3 7/16 | 3 5/16 | 2 15/16 | 2 9/16 | 1 7/8 | 2.15 |
| M-732-EXT-3/4 | 3/4 | 1,365 | 3 1/2 | 3 7/16 | 3 5/16 | 2 15/16 | 2 9/16 | 1 7/8 | 2.36 |
| M-732-EXT-7/8 | 7/8 | 1,365 | 3 1/2 | 3 7/16 | 3 5/16 | 2 15/16 | 2 9/16 | 1 7/8 | 2.49 |

Pipe Straps, Conduit Clamps and Hangers

C-728 — Pipe Roller (Pair)

- Cast aluminum rollers, steel brackets
- Designed for standard saddles
- Order separately for each pair of rollers: Two ½" x ⅝" hex head cap screws, two ½" channel nuts
- Space to fit O.D. of pipe and wrapping
- Adjustable for radius up to 8"

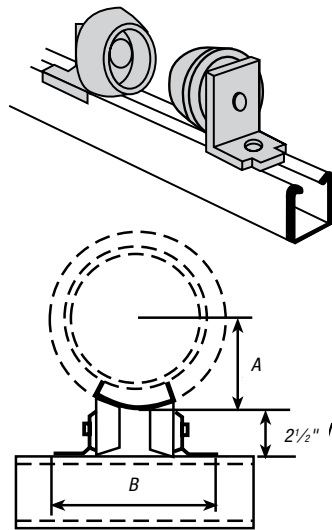

| CAT. NO. | A MAX OS RADIUS (IN.) | B (IN.) | DESIGN LOAD (LBS.) | STD. CTN. |
|----------|-----------------------------|------------|--------------------------|--------------------|
| C728 | 3¾ | 6¼ | 2,350 | 5 pair (10 pieces) |
| | 4¾ | 7½ | 2,350 | 5 pair (10 pieces) |
| | 6¾ | 8½ | 2,350 | 5 pair (10 pieces) |
| | 8½ | 9⅞ | 2,350 | 5 pair (10 pieces) |

C728H — Pipe Roller Assembly (Pair)

Cast aluminum roller, steel brackets. Order separately for each pair of rollers:

- Two ½" x ⅝" hex head cap screws
- Two ½" channel nuts

Adjustable to fit O.D. pipe 6" through 18".

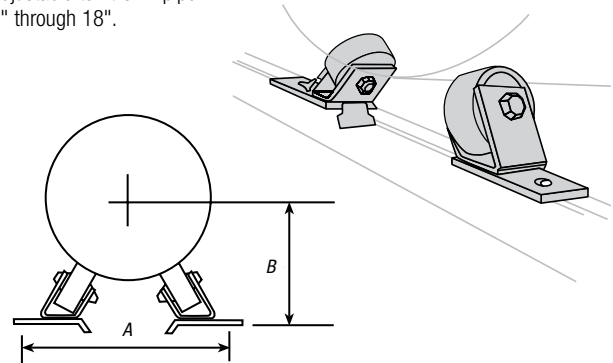

| CAT. NO. | PIPE SIZE (IN.) | A (IN.) | B (IN.) | DESIGN LOAD (LBS.) | STD. CTN. |
|----------|--------------------|------------|------------|-----------------------|--------------------|
| C728H | 6 | 10⅜ | 6⅞ | 3,920 | 5 pair (10 pieces) |
| | 8 | 11⅜ | 7⅞ | 3,920 | 5 pair (10 pieces) |
| | 10 | 12⅞ | 8⅞ | 3,920 | 5 pair (10 pieces) |
| | 12 | 13⅞ | 9⅞ | 3,920 | 5 pair (10 pieces) |
| | 14 | 14½ | 9¾ | 3,920 | 5 pair (10 pieces) |
| | 16 | 15½ | 10⅞ | 3,920 | 5 pair (10 pieces) |
| | 18 | 16½ | 11⅞ | 3,920 | 5 pair (10 pieces) |

CR-729 — Roller Support

Used on steam or hot water systems where pipe is to be supported in tunnels, trenches, structural brackets and frames. Adjustment is made by raising and lowering the top nut on the legs and locked into position by tightening the lower nut.

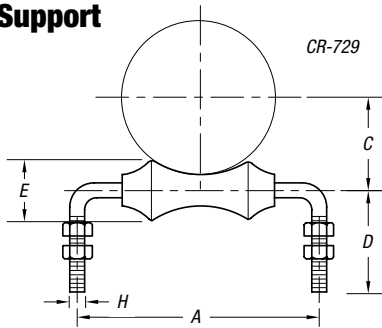

| CR-729 PIPE SIZE OF ROLL | C-789 1" COV. 25 | C-789A 1½" COV. 38 | C-789B 2" COV. 51 | C-789C 2½" COV. 64 | C-789D 3" COV. 76 | C-789E 4" COV. 100 |
|--------------------------------|------------------------|--------------------------|-------------------------|--------------------------|-------------------------|--------------------------|
| 4 | 2½-3 | 2-2½ | — | — | — | — |
| 5 | 3½ | — | — | — | — | — |
| 6 | 4-5 | 3-3½ | 2-2½ | — | — | — |
| 7 | 6 | 4-5 | 3-4 | 2-2½ | 2-2½ | — |
| 8 | 8 | 6 | 5 | 3-3½ | 3-3½ | — |
| 10 | — | 8 | 6 | 4-5 | 4-5 | — |
| 12 | 10 | 10 | 8 | 6 | 6-8 | 4-6 |
| 14 | 12 | 12 | 10 | 8 | — | — |
| 16 | 14 | 14 | 12-14 | 10 | 8 | 8 |

Specifications

- Material: Steel Axle, Cast Iron Roll
- Finish: Standard Finish – GoldGalv®, Black (add suffix "-B"), Electro-Galvanized (add suffix "-EG")

| CAT. NO. | PIPE SIZE (IN.) | MAX. LOAD (LBS.) | DIMENSIONS (IN.) | | | | | WT. EACH (LBS.) |
|--------------|--------------------|---------------------|------------------|----|----|----|---|--------------------|
| | | | A | C | D | E | H | |
| CR-729-2 | 2 | 300 | 4½ | 1¾ | 3¼ | 1⅞ | ¾ | .79 |
| CR-729-2-1/2 | 2½ | 600 | 5 | 1⅞ | 4½ | 1¾ | ½ | 1.44 |
| CR-729-3 | 3 | 600 | 5½ | 2¼ | 4½ | 1⅞ | ½ | 1.62 |
| CR-729-3-1/2 | 3½ | 600 | 7 | 2¾ | 4½ | 1¾ | ½ | 1.64 |
| CR-729-4 | 4 | 700 | 7 | 2⅞ | 4½ | 1⅞ | ½ | 1.82 |
| CR-729-5 | 5 | 700 | 8½ | 3⅞ | 4½ | 2 | ¾ | 2.90 |
| CR-729-6 | 6 | 1,000 | 10 | 4⅞ | 4½ | 2¾ | ¾ | 4.66 |
| CR-729-8 | 8 | 1,300 | 12 | 5½ | 5¼ | 2¼ | ¾ | 7.29 |
| CR-729-10 | 10 | 1,700 | 14 | 6¼ | 5½ | 3¾ | ¾ | 10.23 |
| CR-729-12 | 12 | 2,300 | 16 | 7⅞ | 6 | 3⅞ | ¾ | 12.27 |
| CR-729-14 | 14 | 3,075 | 17 | 8¾ | 7 | 4¼ | 1 | 21.39 |
| CR-729-16 | 16 | 3,075 | 19 | 9⅞ | 8 | 5⅞ | 1 | 27.76 |

Pipe Straps, Conduit Clamps and Hangers

C-729 — Harvard Roll Hanger

Designed to support piping lines from above, allowing for vertical adjustment and axial movement in the piping. The lower nut (not furnished) adjusts the pipe line to the proper elevation. The top nut (not furnished) prevents loosening due to vibration and must be tightened securely to assure proper hanger performance.

Specifications

- Material: Carbon Steel frame with a Cast Iron Roll. Do not exceed 450° F/232° C at the contact point to the roll.
- Compliance: A-A-1192A Type 43 and MSS-SP-69 Type 43
- Finish: Black (add suffix "-B"), Electro-Galvanized (add suffix "-HDG")
- For pipe with insulation and a pipe covering protection saddle the C-729 will have to be oversized to suit. Please see the table below showing the correct sizing for insulated pipe.
- Ordering: Specify pipe size, catalog number and finish.

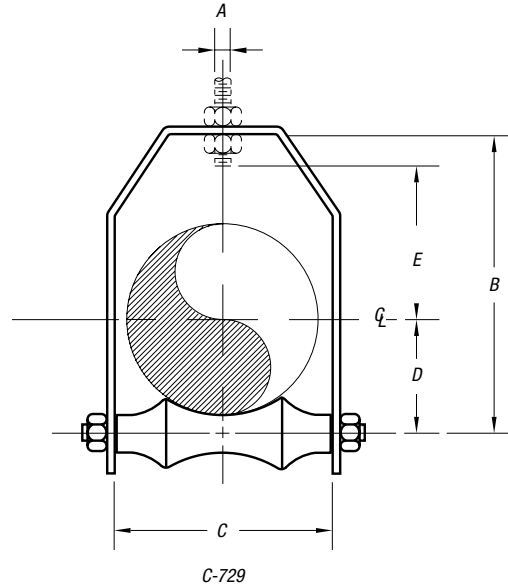

| CAT. NO. | PIPE SIZE (IN.) | MAX. LOAD (LBS.) | DIMENSIONS (IN.) | | | | | WT. EACH (LBS.) |
|-------------|-----------------|------------------|------------------|--------|--------|--------|--------|-----------------|
| | | | ROD SIZE | A | B | C | D | |
| C-729-2 | 2 | 150 | 1/2 | 4 1/4 | 2 3/4 | 1 5/8 | 2 5/8 | 1.60 |
| C-729-2-1/2 | 2 1/2 | 225 | 1/2 | 4 5/8 | 3 1/4 | 2 | 2 7/8 | 2.00 |
| C-729-3 | 3 | 310 | 1/2 | 6 1/4 | 3 3/8 | 2 1/4 | 3 1/8 | 2.30 |
| C-729-3-1/2 | 3 1/2 | 390 | 1/2 | 6 5/8 | 4 1/8 | 2 3/8 | 3 1/2 | 2.50 |
| C-729-4 | 4 | 475 | 5/8 | 7 1/2 | 4 3/8 | 2 3/4 | 3 5/8 | 4.00 |
| C-729-5 | 5 | 685 | 5/8 | 8 3/8 | 6 3/8 | 3 1/2 | 4 1/2 | 5.30 |
| C-729-6 | 6 | 780 | 3/4 | 9 3/8 | 7 3/8 | 4 | 5 | 7.00 |
| C-729-7 | 7 | 780 | 3/4 | 11 1/8 | 8 1/2 | 4 3/4 | 5 1/4 | 9.40 |
| C-729-8 | 8 | 780 | 7/8 | 12 3/8 | 9 1/2 | 5 1/8 | 6 1/8 | 12.30 |
| C-729-10 | 10 | 965 | 7/8 | 15 | 11 1/4 | 6 1/4 | 7 1/4 | 19.30 |
| C-729-12 | 12 | 965 | 7/8 | 17 1/8 | 13 1/2 | 7 1/2 | 8 3/8 | 23.10 |
| C-729-14 | 14 | 1,200 | 1 | 18 3/8 | 14 3/8 | 8 3/8 | 8 3/4 | 35.50 |
| C-729-16 | 16 | 1,400 | 1 | 20 1/2 | 17 1/4 | 9 1/2 | 9 3/4 | 46.50 |
| C-729-18 | 18 | 1,400 | 1 | 23 3/8 | 19 | 10 1/2 | 11 1/2 | 57.00 |
| C-729-20 | 20 | 1,600 | 1 1/4 | 24 1/2 | 21 | 11 1/8 | 12 1/4 | 75.90 |
| C-729-24 | 24 | 1,800 | 1 1/2 | 29 3/8 | 24 1/4 | 14 | 15 1/4 | 119.30 |

Standard Finish – GoldGalv®, unless otherwise stated.

| C-729 PIPE SIZE OF ROLL | C-789 1" COV. 25 | C-789A 1 1/2" COV. 38 | C-789B 2" COV. 51 | C-789C 2 1/2" COV. 64 | C-789D 3" COV. 76 | C-789E 4" COV. 100 |
|-------------------------|------------------|-----------------------|-------------------|-----------------------|-------------------|--------------------|
| 2 1/2 | 3/4 | — | — | — | — | — |
| 3 | 1-1 1/2 | — | — | — | — | — |
| 4 | 2-2 1/2 | 1-1 1/2 | — | — | — | — |
| 5 | 3-3 1/2 | 2-2 1/2 | 3/4-1 1/2 | — | — | — |
| 6 | 4 | 3-3 1/2 | 2-2 1/2 | 3/4-1 | — | — |
| 7 | 5 | 4 | 3-3 1/2 | 1 1/4-1 1/2 | 2 | — |
| 8 | 6 | 5 | 4 | 2-3 | 2 1/2 | — |
| 10 | 8 | 6 | 5-6 | 3 1/2-5 | 3-4 | — |
| 12 | 10 | 8 | 8 | 6 | 5-6 | — |
| 14 | 12 | 10 | — | 8 | 5-6 | — |
| 16 | 14 | 12 | 10 | 10 | 8 | 8 |
| 18 | — | 14 | 14 | 12 | 12 | 10 |
| 20 | — | 16 | 16 | 14 | 14 | 12 |
| 24 | — | 20 | 20 | 18 | 18 | 16 |

Standard Finish – GoldGalv®, unless otherwise stated.

Pipe Straps, Conduit Clamps and Hangers

CR-729A — Roller Chair

Designed for longitudinal movement of pipe where vertical adjustment is not required. Although two bolts are supplied for installation, the chair can be alternatively welded in position.

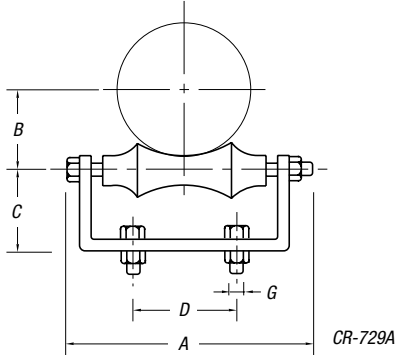

Specifications

- Material: Carbon Steel Chair and Axle with Cast Iron Pipe Roll. Use a Figure 17 when a Cast Iron Chair is required. Do not exceed 450° F/232° C at the contact point to the roll.
- Finish: Standard Finish – GoldGalv®, Black (add suffix “-B”), Electro-Galvanized (add suffix “-EG”).
- For pipe with insulation and a pipe covering protection saddle, the CR-729A will have to be oversized to suit.
- Please see the Table for the RC-729A which shows the correct sizing for insulated pipe.
- Ordering: Specify pipe size, catalog number and finish.

| CAT. NO. | PIPE SIZE (IN.) | MAX. LOAD (LBS.) | DIMENSIONS (IN.) | | | | BOLT SIZE G (IN.) | WT. EACH (LBS.) |
|---------------|-----------------|------------------|------------------|------------------|-----------------|------------------|---------------------------------|-----------------|
| | | | A | B | C | D | | |
| CR-729-2A | 2 | 300 | 4 $\frac{1}{8}$ | 1 $\frac{1}{2}$ | 1 $\frac{1}{2}$ | 2 | $\frac{3}{8}$ x 1 $\frac{1}{2}$ | 1.10 |
| CR-729-2-1/2A | 2 $\frac{1}{2}$ | 600 | 4 $\frac{1}{8}$ | 2 | 1 $\frac{1}{2}$ | 2 | $\frac{3}{8}$ x 1 $\frac{1}{2}$ | 1.40 |
| CR-729-3A | 3 | 600 | 6 | 2 $\frac{1}{4}$ | 1 $\frac{1}{4}$ | 2 | $\frac{3}{8}$ x 1 $\frac{1}{2}$ | 1.60 |
| CR-729-3-1/2A | 3 $\frac{1}{2}$ | 600 | 6 $\frac{1}{2}$ | 2 $\frac{3}{8}$ | 2 $\frac{1}{2}$ | 2 | $\frac{3}{8}$ x 1 $\frac{1}{2}$ | 2.60 |
| CR-729-4A | 4 | 700 | 7 | 2 $\frac{3}{8}$ | 2 $\frac{3}{8}$ | 2 $\frac{1}{2}$ | $\frac{3}{8}$ x 1 $\frac{1}{2}$ | 2.90 |
| CR-729-5A | 5 | 700 | 7 $\frac{3}{8}$ | 3 $\frac{1}{2}$ | 2 $\frac{1}{2}$ | 3 | $\frac{1}{2}$ x 2 | 3.90 |
| CR-729-6A | 6 | 1,000 | 9 $\frac{3}{4}$ | 4 | 2 $\frac{3}{4}$ | 3 $\frac{1}{4}$ | $\frac{1}{2}$ x 2 | 6.00 |
| CR-729-8A | 8 | 1,300 | 11 $\frac{1}{2}$ | 5 $\frac{1}{8}$ | 3 | 4 $\frac{1}{2}$ | $\frac{3}{4}$ x 2 | 9.00 |
| CR-729-10A | 10 | 1,700 | 14 $\frac{1}{2}$ | 6 $\frac{3}{8}$ | 3 $\frac{3}{8}$ | 5 | $\frac{3}{4}$ x 2 $\frac{1}{2}$ | 13.80 |
| CR-729-12A | 12 | 2,300 | 16 $\frac{1}{4}$ | 7 $\frac{1}{2}$ | 4 $\frac{1}{8}$ | 6 | $\frac{3}{4}$ x 2 $\frac{1}{2}$ | 18.90 |
| CR-729-14A | 14 | 3,100 | 18 $\frac{1}{2}$ | 8 $\frac{3}{8}$ | 4 $\frac{3}{4}$ | 6 $\frac{1}{2}$ | $\frac{3}{4}$ x 2 $\frac{1}{2}$ | 28.10 |
| CR-729-16A | 16 | 3,900 | 20 | 9 $\frac{3}{8}$ | 5 $\frac{1}{2}$ | 10 | $\frac{3}{4}$ x 3 | 34.90 |
| CR-729-18A | 18 | 4,200 | 22 $\frac{3}{4}$ | 10 $\frac{1}{2}$ | 6 | 9 $\frac{1}{4}$ | $\frac{3}{4}$ x 2 $\frac{1}{2}$ | 44.40 |
| CR-729-20A | 20 | 4,500 | 25 $\frac{1}{2}$ | 11 $\frac{1}{8}$ | 6 $\frac{1}{2}$ | 10 $\frac{1}{4}$ | $\frac{3}{4}$ x 2 $\frac{1}{2}$ | 56.30 |
| CR-729-24 | 24 | 6,000 | 30 | 14 | 7 $\frac{1}{8}$ | 12 $\frac{1}{4}$ | $\frac{7}{8}$ x 3 $\frac{1}{2}$ | 87.50 |

Standard Finish – GoldGalv®, unless otherwise stated.

RC-729 — Adjustable Roll Support

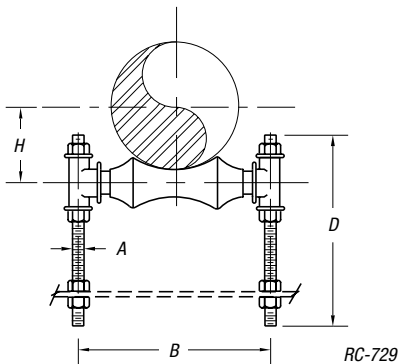

Specifications

- Material: Cast Iron Pipe Roll and Sockets, Carbon Steel Axle, Continuous Thread Rods and Hex Nuts. Do not exceed 450° F/232° C at the contact point to the roll.
- Finish: Standard Finish – GoldGalv®, Black (add suffix “-B”), Electro-Galvanized (add suffix “-EG”).
- For pipe with insulation and a pipe covering protection saddle, the RC-729 will have to be oversized to suit.
- Please see the table for the RC-729A which shows the correct sizing for insulated pipe.
- Ordering: Specify pipe size, catalog number and finish.

| CAT. NO. | PIPE SIZE (IN.) | MAX. LOAD (LBS.) | DIMENSIONS (IN.) | | | | WT. EACH (LBS.) |
|--------------|-----------------|------------------|------------------|------------------|-----------------|------------------|-----------------|
| | | | A | B | D | H | |
| RC-729-1-1/4 | 1 $\frac{1}{4}$ | 300 | $\frac{3}{8}$ | 3 $\frac{3}{8}$ | 7 $\frac{1}{4}$ | 1 $\frac{1}{4}$ | 1.08 |
| RC-729-1-1/2 | 1 $\frac{1}{2}$ | 300 | $\frac{3}{8}$ | 3 $\frac{3}{8}$ | 7 $\frac{1}{4}$ | 1 $\frac{1}{4}$ | 1.11 |
| RC-729-2 | 2 | 300 | $\frac{3}{8}$ | 4 $\frac{1}{8}$ | 7 $\frac{1}{4}$ | 1 $\frac{1}{8}$ | 1.65 |
| RC-729-2-1/2 | 2 $\frac{1}{2}$ | 600 | $\frac{1}{2}$ | 5 $\frac{1}{2}$ | 8 | 2 | 2.72 |
| RC-729-3 | 3 | 600 | $\frac{1}{2}$ | 6 $\frac{1}{8}$ | 8 | 2 $\frac{1}{4}$ | 2.72 |
| RC-729-3-1/2 | 3 $\frac{1}{2}$ | 700 | $\frac{1}{2}$ | 7 $\frac{1}{8}$ | 8 | 2 $\frac{3}{8}$ | 2.72 |
| RC-729-4 | 4 | 700 | $\frac{5}{8}$ | 7 $\frac{1}{8}$ | 8 $\frac{1}{2}$ | 2 $\frac{3}{8}$ | 3.91 |
| RC-729-5 | 5 | 700 | $\frac{5}{8}$ | 8 $\frac{3}{8}$ | 9 | 3 $\frac{1}{2}$ | 4.63 |
| RC-729-6 | 6 | 1,000 | $\frac{3}{4}$ | 9 $\frac{3}{8}$ | 9 | 4 | 7.07 |
| RC-729-8 | 8 | 1,300 | $\frac{7}{8}$ | 12 | 10 | 5 $\frac{1}{8}$ | 11.40 |
| RC-729-10 | 10 | 1,700 | $\frac{7}{8}$ | 14 $\frac{1}{8}$ | 11 | 6 $\frac{1}{8}$ | 13.70 |
| RC-729-12 | 12 | 2,300 | $\frac{7}{8}$ | 16 $\frac{1}{8}$ | 12 | 7 $\frac{1}{2}$ | 15.90 |
| RC-729-14 | 14 | 3,075 | 1 | 17 $\frac{1}{4}$ | 12 | 8 $\frac{3}{8}$ | 28.70 |
| RC-729-16 | 16 | 3,970 | 1 | 19 $\frac{1}{4}$ | 18 | 9 $\frac{1}{2}$ | 42.50 |
| RC-729-18 | 18 | 4,200 | 1 | 21 $\frac{1}{8}$ | 18 | 10 $\frac{1}{2}$ | 46.60 |
| RC-729-20 | 20 | 4,550 | 1 $\frac{1}{4}$ | 24 $\frac{1}{4}$ | 18 | 11 $\frac{1}{8}$ | 66.20 |
| RC-729-24 | 24 | 6,160 | 1 $\frac{1}{2}$ | 28 $\frac{3}{8}$ | 24 | 14 | 102.50 |
| RC-729-30 | 30 | 7,290 | 1 $\frac{1}{2}$ | 35 $\frac{1}{2}$ | 24 | 17 $\frac{1}{2}$ | 186.80 |

Standard Finish – GoldGalv®, unless otherwise stated.

Pipe Straps, Conduit Clamps and Hangers

RC-729A — Adjustable Roll Support

Designed for longitudinal movement of pipe where vertical adjustment is required. Although primarily used for support of the pipe, this component may also be placed over the pipe to act as a guide.

Specifications

- Material: Cast Iron Pipe Roll and Sockets with a Carbon Steel Axle. Do not exceed 450° F/232° C at the contact point to the roll.
 - Compliance: A-A-1192A Type 42, MSS SP-69 Type 41.
 - Finish: Black (add suffix "-B"). Electro-Galvanized (add suffix "-HDG").
- For pipe with insulation and a pipe covering protection saddle, the RC-729A will have to be oversized to the roll.
- Please see the table below which shows the correct sizing for insulated pipe.
- Ordering: Specify pipe size, catalog number and finish.

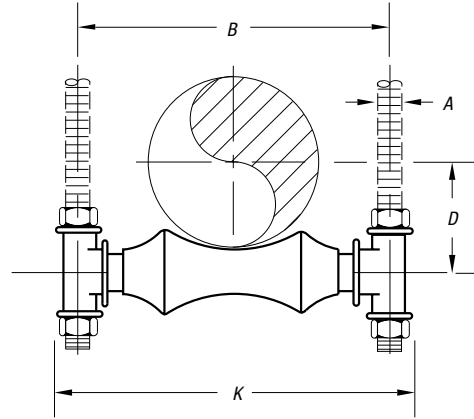

RC-729A

| CAT. NO. | PIPE SIZE (IN.) | MAX. LOAD (LBS.) | DIMENSIONS (IN.) | | | | WT. EACH (LBS.) |
|---------------|-----------------|------------------|------------------|--------|--------|--------|-----------------|
| | | | ROD SIZE A | B | D | K | |
| RC-729A-1 | 1 | 600 | 3/8 | 3 | 1 | 4 1/2 | .45 |
| RC-729A-1-1/4 | 1 1/4 | 600 | 3/8 | 3 3/8 | 1 1/4 | 4 1/2 | .48 |
| RC-729A-1-1/2 | 1 1/2 | 600 | 3/8 | 3 3/8 | 1 3/8 | 4 3/4 | .51 |
| RC-729A-2 | 2 | 600 | 3/8 | 4 1/8 | 1 3/8 | 5 1/4 | .57 |
| RC-729A-2-1/2 | 2 1/2 | 600 | 1/2 | 5 1/2 | 2 | 7 | 1.48 |
| RC-729A-3 | 3 | 700 | 1/2 | 6 1/8 | 2 1/4 | 7 3/4 | 1.48 |
| RC-729A-4 | 4 | 700 | 5/8 | 7 1/8 | 2 3/8 | 8 3/8 | 1.78 |
| RC-729A-5 | 5 | 700 | 5/8 | 8 3/8 | 3 1/2 | 9 3/4 | 2.42 |
| RC-729A-6 | 6 | 1,000 | 3/4 | 9 3/8 | 4 | 11 3/8 | 3.96 |
| RC-729A-7 | 7 | 1,200 | 3/4 | 10 3/4 | 4 3/4 | 12 1/2 | 5.99 |
| RC-729A-8 | 8 | 1,300 | 7/8 | 12 | 5 1/2 | 14 | 6.43 |
| RC-729A-10 | 10 | 1,700 | 7/8 | 14 1/8 | 6 1/4 | 16 | 8.45 |
| RC-729A-12 | 12 | 2,400 | 7/8 | 16 1/8 | 7 1/2 | 18 | 10.20 |
| RC-729A-14 | 14 | 3,100 | 1 | 17 3/4 | 8 3/8 | 20 | 20.90 |
| RC-729A-16 | 16 | 3,900 | 1 | 19 3/8 | 9 1/2 | 22 1/2 | 26.07 |
| RC-729A-18 | 18 | 4,200 | 1 | 22 1/2 | 10 1/2 | 24 3/4 | 36.59 |
| RC-729A-20 | 20 | 4,500 | 1 1/4 | 24 1/8 | 11 3/8 | 26 3/4 | 39.00 |
| RC-729A-24 | 24 | 6,100 | 1 1/2 | 28 3/8 | 14 | 32 1/2 | 66.90 |
| RC-729A-30 | 30 | 7,200 | 1 1/2 | 35 1/2 | 17 1/2 | 39 3/4 | 134.00 |

| RC-729A PIPE SIZE OF ROLL | PIPE SIZE OF COVERING PROTECTION SADDLE TO BE USED WITH RC-729A | | | | | |
|---------------------------|---|-----------------------|-------------------|-----------------------|-------------------|--------------------|
| | C-789 1" COV. 25 | C-789A 1 1/2" COV. 38 | C-789B 2" COV. 51 | C-789C 2 1/2" COV. 64 | C-789D 3" COV. 76 | C-789E 4" COV. 100 |
| 2 1/2 | 3/4-1 | — | — | — | — | — |
| 3 | 1 1/4-1 1/2 | 3/4-1 | — | — | — | — |
| 4 | 2 1/2-3 | 1 1/2 | 3/4-1 | — | — | — |
| 5 | 3 1/2 | 2-2 1/2 | 1 1/4-1 1/2 | 3/4-1 | — | — |
| 6 | 4-5 | 3-3 1/2 | 2-2 1/2 | 1 1/4-1 1/2 | — | — |
| 7 | 6 | 4-5 | 3-4 | 2-2 1/2 | 2-2 1/2 | — |
| 8 | — | 6 | 5 | 3-3 1/2 | 3-3 1/2 | — |
| 10 | 8 | 8 | 6 | 4-5 | 4-5 | — |
| 12 | 10 | 10 | 8 | 6 | 6-8 | 4-6 |
| 14 | 12 | 12 | 10 | 8 | — | — |
| 16 | 14 | 14 | 12-14 | 10 | 10 | 8 |
| 18 | 16 | 16 | 16 | 12-14 | 12-14 | 10 |
| 20 | 18 | 18 | — | 16 | — | 12 |
| 24 | 20 | 20 | 18-20 | 18-20 | 16-20 | 14-18 |
| 30 | 24 | 24 | 24 | 24 | 24 | 20-24 |

Standard Finish — GoldGalv®, unless otherwise stated.

Pipe Straps, Conduit Clamps and Hangers

S-730-C — Chair and Roll

Designed for longitudinal movement of pipe where vertical adjustment is not required. Because the chair is made of steel, it can be either welded or bolted in position.

Specifications

- Material: Carbon Steel Chair and Axle with Cast Iron Pipe Roll. Use a Figure 17 when a Cast Iron Chair is required. Do not exceed 450° F/232° C at the contact point to the roll.
- Compliance: Federal Specification A-A-1192A Type 44, MSS-SP-69 Type 44.
- Finish: Black (add suffix "-B"). Electro-Galvanized (add suffix "-HDG").
- For pipe with insulation and a pipe covering protection saddle, the S-730-C will have to be oversized to suit.
- Please see the Table below showing the correct sizing for insulated pipe.
- Ordering: Specify chair number, catalog number and finish.

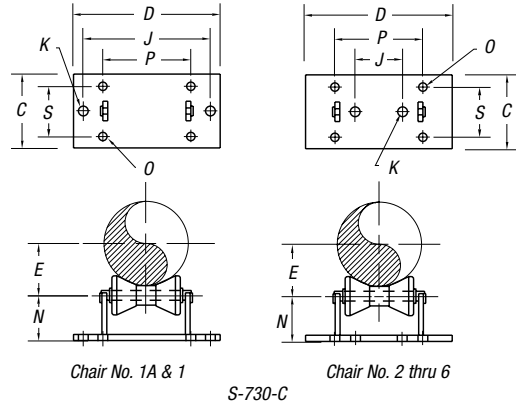

| CHAIR NO. | BARE PIPE SIZE | C-789 1" COV. 25 | C-789A 1½" COV. 38 | C-789B 2" COV. 51 | C-789C 2½" COV. 64 | C-789D 3" COV. 76 | C-789E 4" COV. 102 |
|---------------------------------|----------------|---------------------|-----------------------|----------------------|-----------------------|----------------------|-----------------------|
| 1 ²⁵ / ₃₂ | 2 | — | — | — | — | — | — |
| — | 2½ | ¾-3 | ¾-2½ | ¾-1¼ | — | — | — |
| — | 3 | 20-80 | 20-65 | 20-40 | — | — | — |
| — | 3½ | — | — | — | — | — | — |
| 1 | 4 | 4-6 | 3-5 | 2-4 | ¾-1½ | — | — |
| — | 5 | 100-150 | 80-125 | 50-100 | 20-40 | — | — |
| — | 6 | — | — | — | — | — | — |
| 2 | 8 | 8 | 6-8 | 5-8 | 2-5 | 2-6 | 4-5 |
| — | 10 | 200 | 150-200 | 125-200 | 50-125 | 50-150 | 100-125 |
| 3 | 12 | 10-12 | 10-12 | 10-12 | 6-8 | 8 | 6-8 |
| — | 14 | 250-300 | 250-300 | 250-300 | 150-200 | 200 | 150-200 |
| 4 | 16 | 14-18 | 14-18 | 14-18 | 10-16 | 10-14 | 10-12 |
| — | 18 | 350-450 | 350-450 | 350-450 | 250-400 | 250-350 | 250-300 |
| — | 20 | — | — | — | — | — | — |
| 5 | 24 | 20 | 20 | 18-20 | 18-20 | 16-18 | 14-18 |
| 5 | 600 | 500 | 500 | 450-500 | 450-500 | 400-450 | 350-450 |
| 6 | 30 | 24 | 24 | 24 | 24 | 20-24 | 20-24 |
| 6 | 750 | 600 | 600 | 600 | 600 | 500-600 | 500-600 |
| 7 | 36 | 30 | 30 | 30 | 30 | 30 | 28 |
| — | 900 | 750 | 750 | 750 | 750 | 750 | 700 |
| 7 | 42 | 40 | 36 | 36 | 36 | 36 | 32 |
| — | 1,050 | 1,000 | 900 | 900 | 900 | 900 | 800 |

| CAT. NO. | CHAIR NO. | MAX. LOAD (LBS.) | BARE PIPE SIZE (IN.) | DIMENSIONS (IN.) | | | | | | | | | | WT. EACH (LBS.) |
|------------|---------------------------------|------------------|----------------------|------------------|-----|-----|----|---|---|----|------|-----|----|-----------------|
| | | | | C | D | E | J | K | M | N | O | P | S | |
| S-730-C-1A | 1 ²⁵ / ₃₂ | 390 | 2 | 6 | 8½ | 1½ | 6½ | 1 | ¼ | 2 | 4/64 | 3½ | 4½ | 7.0 |
| | | | 2½ | | | 1¾ | | | | | | | | |
| | | | 3 | | | 2½ | | | | | | | | |
| S-730-C-1 | 1 | 950 | 4 | 6 | 10⅝ | 2¼ | 8 | 1 | ¼ | 2⅜ | 4/64 | 4¾ | 4¾ | 10.5 |
| | | | 5 | | | 3¾ | | | | | | | | |
| | | | 6 | | | 3¾ | | | | | | | | |
| S-730-C-2 | 2 | 2,100 | 8 | 7 | 9 | 5½ | 4 | 1 | ¾ | 3¼ | 1/16 | 7 | 5 | 16.5 |
| | | | 10 | | | 6¼ | | | | | | | | |
| S-730-C-3 | 3 | 3,075 | 12 | 8 | 11 | 7¾ | 5¼ | 1 | ¾ | 4¾ | 1/16 | 9 | 6 | 26.8 |
| | | | 14 | | | 8 | | | | | | | | |
| S-730-C-4 | 4 | 4,980 | 16 | 9 | 12½ | 8⅝ | 6¼ | 1 | ½ | 4¾ | 1/16 | 10 | 6½ | 40.5 |
| | | | 18 | | | 10 | | | | | | | | |
| | | | 20 | | | 11 | | | | | | | | |
| S-730-C-5 | 5 | 6,100 | 24 | 8¾ | 13¾ | 13 | 7½ | 1 | ¾ | 4⅞ | 1/16 | 11½ | 6¾ | 51.0 |
| S-730-C-6 | 6 | 7,500 | 30 | 11 | 17¼ | 16¼ | 10 | 1 | ¾ | 5⅞ | 1/16 | 14¾ | 8 | 89.8 |
| S-730-C-7 | 7 | 12,000 | 36 | 12 | 20 | 20 | 12 | 1 | 1 | 5⅞ | 1/16 | 17 | 9 | 145 |
| | | | 42 | | | 23⅜ | | | | | | | | |

Pipe Straps, Conduit Clamps and Hangers

C-786 — Adjustable Pipe Support

Used for support of piping from below without welding to the pipe, and consists of a steel saddle, nipple and pipe reducer. It connects to a threaded pipe standard and base.

Rated loads are for up to 650° F (343° C).

Specifications

- Materials: Reducer is Cast Iron, Pipe saddle and nipple are carbon steel.
- Compliance: Federal Specification A-A-1192A Type 39, MSS-SP-69 Type 39.
- Finish: Standard Finish – GoldGalv®, Black (add suffix “-B”), Electro-Galvanized (add suffix “-EG”).
- Ordering: Specify pipe size, catalog number and finish.

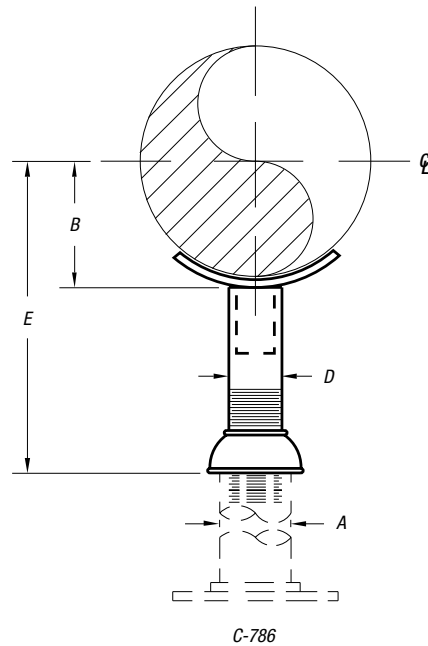

| CAT. NO. | PIPE SIZE (IN.) | MAX. LOAD (LBS.) | DIMENSIONS (IN.) | | | | | WT. EACH (LBS.) |
|-------------|-----------------|------------------|------------------|-----|----|--------|--------|-----------------|
| | | | A | B | D | MIN. E | MAX. E | |
| C-786-1-1/2 | 1½ | 5,000 | 2½ | 1¼ | 1½ | 8 | 13 | 4.75 |
| C-786-2 | 2 | 5,000 | 2½ | 1½ | 1½ | 8 | 13 | 4.80 |
| C-786-2-1/2 | 2½ | 5,000 | 2½ | 1¾ | 1½ | 8 | 13 | 4.90 |
| C-786-3 | 3 | 5,000 | 2½ | 2¼ | 1½ | 8¼ | 13¼ | 5.00 |
| C-786-4 | 4 | 7,000 | 3 | 2¾ | 2½ | 9½ | 14½ | 9.30 |
| C-786-5 | 5 | 7,000 | 3 | 3¼ | 2½ | 9¾ | 14¾ | 9.65 |
| C-786-6 | 6 | 7,000 | 3 | 3¾ | 2½ | 10¼ | 15¼ | 11.70 |
| C-786-8 | 8 | 7,000 | 3 | 4¾ | 2½ | 11¼ | 16¼ | 12.90 |
| C-786-10 | 10 | 7,000 | 3 | 5¾ | 2½ | 12¾ | 17¾ | 14.10 |
| C-786-12 | 12 | 7,000 | 3 | 6¾ | 2½ | 13¾ | 18¾ | 15.30 |
| C-786-14 | 14 | 7,000 | 4 | 7¾ | 3 | 15½ | 20½ | 21.70 |
| C-786-16 | 16 | 7,000 | 4 | 8¾ | 3 | 16¾ | 21¾ | 25.40 |
| C-786-18 | 18 | 7,000 | 6 | 9¾ | 4 | 19¾ | 24¾ | 39.30 |
| C-786-20 | 20 | 7,000 | 6 | 10¾ | 4 | 20¾ | 25¾ | 44.90 |
| C-786-24 | 24 | 10,000 | 6 | 12¾ | 4 | 22¼ | 27¼ | 54.30 |
| C-786-30 | 30 | 10,000 | 6 | 15¾ | 4 | 25¼ | 30¼ | 62.40 |
| C-786-36 | 36 | 10,000 | 6 | 18¾ | 4 | 28¼ | 33¼ | 70.20 |

Standard Finish – GoldGalv®, unless otherwise stated.

Pipe Straps, Conduit Clamps and Hangers

C-789, C-789A, C789B, C-789C, C-789D, C-789E — Pipe Covering Protection Saddle

The C-789 saddles are used to protect the insulation against damage and keep heat loss to a minimum. They are designed for 1" to 5" of covering. All Saddles are 12" long with three tabs on each side for welding to pipe. Sizes 12" and larger have a welded-in center rib.

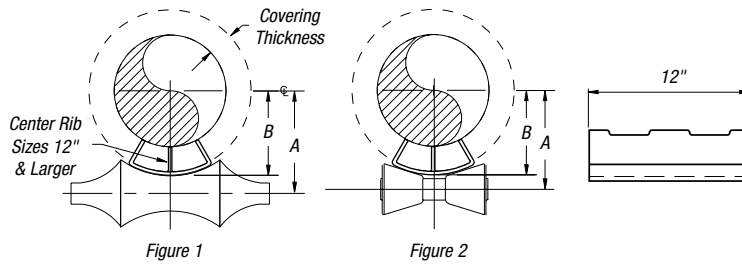

C-789

Specifications

- Material: Carbon Steel (except C-789 and C-789-8 which are Chromium Molybdenum Steel).
- Compliance: Federal Specification A-A-1192A Type 39A or 39B, MSS-SP-69 Type 39A or 39B and BSPSS-BS3974.
- Finish: Standard Finish – GoldGalv®, Black (add suffix “-B”), Electro-Galvanized (add suffix “-EG”).
- Ordering: Specify catalog number and pipe size.

Pipe Saddles and Pipe Shields

| CAT. NO. | PIPE SIZE (IN.) | MAX. COVERING THICKNESS (IN.) | ACTUAL COVERING THICKNESS (IN.) | MAX. LOAD (LBS.) | FIGURE 1 (IN.) | | | FIGURE 2 (IN.) | | | WT. EACH (LBS.) |
|--------------|-----------------|-------------------------------|---------------------------------|------------------|----------------|--------|--------|----------------|---------|--------|-----------------|
| | | | | | ROLL SIZE | A | B | ROLL SIZE | A | B | |
| C-789-3/4 | 3/4 | 1 | 15/16 | 1,200 | 2 1/2 | 2 1/8 | 1 3/8 | 2-3 1/2 | 2 5/16 | 1 1/8 | 1.15 |
| C-789A-3/4 | 3/4 | 1 1/2 | 1 1/2 | 1,200 | 3 | 2 3/8 | 2 1/8 | 2-3 1/2 | 2 11/16 | 2 1/4 | 2.10 |
| C-789B-3/4 | 3/4 | 2 | 2 | 1,200 | 4 | 3 1/4 | 2 3/8 | 2-3 1/2 | 3 3/8 | 2 3/8 | 2.63 |
| C-789-1 | 1 | 1 | 1 1/16 | 1,200 | 2 1/4 | 2 3/4 | 1 3/4 | 2-3 1/2 | 2 7/16 | 1 1/4 | 1.15 |
| C-789A-1 | 1 | 1 1/2 | 1 3/16 | 1,200 | 3 | 2 7/8 | 2 3/8 | 2-3 1/2 | 2 5/16 | 2 3/8 | 2.10 |
| C-789B-1 | 1 | 2 | 2 1/8 | 1,200 | 4 | 3 3/8 | 2 3/4 | 2-3 1/2 | 3 1/2 | 2 3/4 | 2.63 |
| C-789-1-1/4 | 1 1/4 | 1 | 7/8 | 1,200 | 3 | 2 1/2 | 2 | 2-3 1/2 | 2 3/16 | 2 | 1.25 |
| C-789A-1-1/4 | 1 1/4 | 1 1/2 | 1 3/8 | 1,200 | 3 1/2 | 3 | 2 1/2 | 2-3 1/2 | 3 3/16 | 2 1/2 | 2.10 |
| C-789B-1-1/4 | 1 1/4 | 2 | 1 5/16 | 1,200 | 5 | 3 3/8 | 3 1/16 | 2-3 1/2 | 3 11/16 | 3 1/16 | 2.63 |
| C-789C-1-1/4 | 1 1/4 | 2 1/2 | 2 1/2 | 1,200 | 6 | 4 1/4 | 3 1/2 | 4-6 | 4 1/16 | 3 1/2 | 3.25 |
| C-789-1-1/2 | 1 1/2 | 1 | 1 1/16 | 1,200 | 3 | 2 1/2 | 2 | 2-3 1/2 | 2 11/16 | 2 | 1.50 |
| C-789A-1-1/2 | 1 1/2 | 1 1/2 | 1 3/16 | 1,200 | 4 | 3 1/8 | 2 3/8 | 2-3 1/2 | 3 3/16 | 2 3/8 | 2.10 |
| C-789B-1-1/2 | 1 1/2 | 2 | 2 3/8 | 1,800 | 5 | 4 9/16 | 3 3/8 | 2-3 1/2 | 3 3/4 | 3 3/8 | 3.10 |
| C-789C-1-1/2 | 1 1/2 | 2 1/2 | 2 3/8 | 1,800 | 6 | 4 3/8 | 3 3/8 | 4-6 | 4 3/16 | 3 3/8 | 3.75 |
| C-789-2 | 2 | 1 | 1 1/16 | 1,200 | 3 1/2 | 2 3/8 | 2 3/8 | 2-3 1/2 | 2 15/16 | 2 3/8 | 1.63 |
| C-789A-2 | 2 | 1 1/2 | 1 3/16 | 1,200 | 4 | 3 3/16 | 2 3/8 | 2-3 1/2 | 3 3/16 | 2 3/8 | 2.10 |
| C-789B-2 | 2 | 2 | 2 1/8 | 1,800 | 6 | 4 1/4 | 3 1/2 | 4-6 | 3 3/8 | 3 1/2 | 3.12 |
| C-789C-2 | 2 | 2 1/2 | 2 3/8 | 1,800 | 7 | 4 3/4 | 4 | 4-6 | 4 13/16 | 4 | 3.63 |
| C-789D-2 | 2 | 3 | 3 1/16 | 1,800 | 7 | 5 1/4 | 4 1/2 | 7-10 | 5 5/16 | 4 1/2 | 4.40 |
| C-789-2-1/2 | 2 1/2 | 1 | 1 1/16 | 1,200 | 4 | 3 1/2 | 2 3/8 | 2-3 1/2 | 3 3/16 | 2 3/8 | 1.75 |
| C-789A-2-1/2 | 2 1/2 | 1 1/2 | 1 3/8 | 1,200 | 6 | 4 1/2 | 3 3/8 | 2-3 1/2 | 3 3/4 | 3 3/8 | 2.40 |
| C-789B-2-1/2 | 2 1/2 | 2 | 2 3/8 | 1,800 | 6 | 4 3/8 | 3 3/8 | 4-6 | 4 3/16 | 3 3/8 | 3.12 |
| C-789C-2-1/2 | 2 1/2 | 2 1/2 | 2 3/8 | 1,800 | 7 | 5 1/16 | 4 3/8 | 7-10 | 5 1/16 | 4 3/8 | 3.63 |
| C-789D-2-1/2 | 2 1/2 | 3 | 3 3/8 | 1,800 | 7 | 5 3/8 | 4 3/8 | 7-10 | 5 3/16 | 4 3/8 | 4.40 |

Standard Finish – GoldGalv®, unless otherwise stated.

Pipe Straps, Conduit Clamps and Hangers

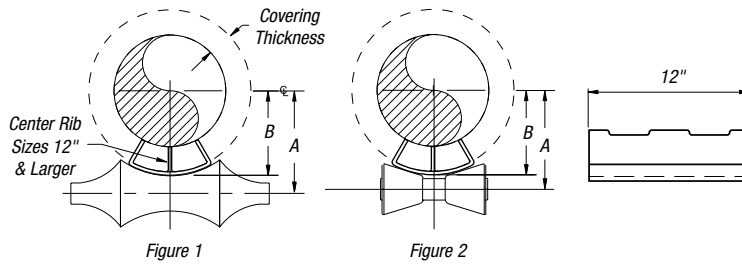

C-789

Pipe Saddles and Pipe Shields (Continued)

| CAT. NO. | PIPE SIZE (IN.) | MAX. COVERING THICKNESS (IN.) | ACTUAL COVERING THICKNESS (IN.) | MAX. LOAD (LBS.) | FIGURE 1 (IN.) | | | FIGURE 2 (IN.) | | | WT. EACH (LBS.) |
|-----------|-----------------|-------------------------------|---------------------------------|------------------|----------------|-----|-----|----------------|-----|-----|-----------------|
| | | | | | ROLL SIZE | A | B | ROLL SIZE | A | B | |
| C-789A-14 | 14 | 1½ | 1½ | 5,000 | 16 | 10¼ | 9 | 16-20 | 10⅝ | 9 | 8.25 |
| C-789B-14 | 14 | 2 | 2 | 5,000 | 18 | 10¼ | 9⅝ | 16-20 | 10¼ | 9⅝ | 9.20 |
| C-789C-14 | 14 | 2½ | 2⅝ | 5,000 | 18 | 11⅝ | 9⅝ | 16-20 | 11¼ | 9⅝ | 10.04 |
| C-789D-14 | 14 | 3 | 3 | 5,000 | 18 | 12 | 10½ | 16-20 | 11¾ | 10½ | 11.00 |
| C-789E-14 | 14 | 4 | 4 | 5,000 | 24 | 13¼ | 11¾ | 22-24 | 12⅜ | 11¾ | 15.50 |
| C-789-14 | 14 | 4 | 4 | 11,000 | 24 | 12¾ | 11¼ | 22-24 | 11⅞ | 11¼ | 27.60 |
| C-789-14 | 14 | 5½ | 5½ | 11,000 | 24 | 15 | 13⅝ | 24 | 14½ | 13⅝ | 36.60 |
| C-789A-16 | 16 | 1½ | 1½ | 5,000 | 18 | 11⅝ | 9¼ | 16-20 | 11¼ | 9¼ | 8.25 |
| C-789B-16 | 16 | 2 | 2 | 5,000 | 20 | 11¾ | 10¼ | 16-20 | 11⅝ | 10¼ | 9.20 |
| C-789C-16 | 16 | 2½ | 2½ | 7,200 | 20 | 12¼ | 10¼ | 16-20 | 12¼ | 10¼ | 13.69 |
| C-789D-16 | 16 | 3 | 3 | 7,200 | 24 | 12⅝ | 11⅝ | 22-24 | 12⅞ | 11⅝ | 14.65 |
| C-789E-16 | 16 | 4 | 4 | 7,200 | 24 | 14 | 12¼ | 22-24 | 13⅞ | 12¼ | 15.50 |
| C-789-16 | 16 | 4 | 4 | 11,000 | 24 | 14 | 12¼ | 22-24 | 13⅞ | 12¼ | 30.10 |
| C-789-16 | 16 | 5½ | 5½ | 11,000 | 30 | 16⅝ | 13⅞ | 30 | 15¼ | 13⅞ | 39.00 |
| C-789A-18 | 18 | 1½ | 1½ | 5,000 | 20 | 12¼ | 10¾ | 16-20 | 12¼ | 10¾ | 9.35 |
| C-789B-18 | 18 | 2 | 2 | 7,200 | 24 | 13⅝ | 11⅝ | 22-24 | 12⅜ | 11⅝ | 12.00 |
| C-789C-18 | 18 | 2½ | 2½ | 7,200 | 24 | 13½ | 11¾ | 22-24 | 13 | 11¾ | 14.19 |
| C-789D-18 | 18 | 3 | 3 | 7,200 | 24 | 14 | 12¼ | 22-24 | 13½ | 12¼ | 15.25 |
| C-789E-18 | 18 | 4 | 4 | 7,200 | 24 | 15⅝ | 13⅞ | 22-24 | 14⅞ | 13⅞ | 21.00 |
| C-789-18 | 18 | 4 | 4 | 13,200 | 24 | 15⅝ | 13⅞ | 22-24 | 14⅞ | 13⅞ | 40.30 |
| C-789-18 | 18 | 5½ | 5½ | 13,200 | 30 | 17⅓ | 15 | 30 | 16⅞ | 15 | 52.10 |
| C-789A-20 | 20 | 1½ | 1½ | 7,200 | 24 | 13½ | 11¾ | 22-24 | 13 | 11¾ | 11.05 |
| C-789B-20 | 20 | 2 | 2 | 7,200 | 24 | 14 | 12¼ | 22-24 | 13½ | 12¼ | 12.40 |
| C-789C-20 | 20 | 2½ | 2½ | 7,200 | 24 | 14⅞ | 12⅞ | 22-24 | 14⅞ | 12⅞ | 14.19 |
| C-789D-20 | 20 | 3 | 3 | 7,200 | 24 | 15¼ | 13¾ | 26-30 | 14⅞ | 13¾ | 15.25 |
| C-789E-20 | 20 | 4 | 4 | 7,200 | 30 | 16½ | 14¼ | 26-30 | 15¼ | 14¼ | 22.80 |
| C-789-20 | 20 | 4 | 4 | 13,200 | 7 | 16⅝ | 14⅞ | 26-30 | 15⅞ | 14⅞ | 44.80 |
| C-789-20 | 20 | 5½ | 5½ | 13,200 | 30 | 18⅓ | 16 | 30 | 17⅞ | 16 | 52.10 |
| C-789A-24 | 24 | 1½ | 1½ | 7,200 | 30 | 16⅞ | 14⅞ | 26-30 | 15¼ | 14⅞ | 12.90 |
| C-789B-24 | 24 | 2 | 2 | 7,200 | 30 | 16⅞ | 14⅞ | 26-30 | 15¼ | 14⅞ | 13.90 |
| C-789C-24 | 24 | 2½ | 2½ | 7,200 | 30 | 17 | 14¾ | 26-30 | 16⅞ | 14¾ | 18.07 |
| C-789D-24 | 24 | 3 | 3 | 7,200 | 30 | 17½ | 15¼ | 26-30 | 17⅞ | 15¼ | 19.35 |
| C-789E-24 | 24 | 4 | 4 | 7,200 | 30 | 18¼ | 16½ | 26-30 | 18 | 16½ | 23.10 |
| C-789-24 | 24 | 4 | 4 | 13,200 | 30 | 18⅞ | 16⅞ | 26-30 | 18⅞ | 16⅞ | 45.40 |

Standard Finish - GoldGalv®, unless otherwise stated.

Pipe Straps, Conduit Clamps and Hangers

C-790 — Insulation Shield

Designed to protect the insulation and distribute the load at the hanger point. This item is usually used with our C-710 Clevis Hanger.

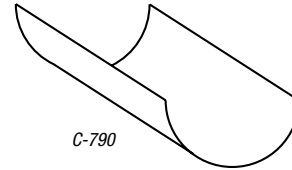

- Specifications**
- Approvals: Federal Specification A-A-1192A Type 40, MSS-SP-69 Type 40
 - Material: Carbon Steel
 - Finish: Standard Finish – GoldGalv®, Black (add suffix “-B”), Electro-Galvanized (add suffix “-EG”)
 - Ordering: Specify hanger size and catalog number

Shield Size Selection Table

| PIPE SIZES | 1/2 | 3/4 | 1 | 1 1/2 | 2 |
|--------------------------------------|-----|-----|-----|-------|-----|
| Insulation Thickness (Inches) | | | | | |
| 1/2 | 1A* | 1A | — | — | — |
| 3/4 | 1A | 1A | 2A | 4A | 6A |
| 1 | 1A | 2A | 3A | 5A | 7A |
| 1 1/4 | 2A | 3A | 4A | 6A | 7A |
| 1 1/2 | 2A | 3A | 4A | 6A | 7A |
| 2 | 3A | 4A | 5A | 7A | 8A |
| 2 1/2 | 4A | 5A | 6A | 7A | 8A |
| 3 | 5A | 6A | 7A | 8A | 9A |
| 3 1/2 | — | — | 8A | 9A | 10A |
| 4 | — | — | 8A | 9A | 10A |
| 5 | — | — | 9B | 10B | 11B |
| 6 | — | — | 10B | 11B | 12B |
| 8 | — | — | — | 13C | 14C |
| 10 | — | — | 14C | 15C | 16C |
| 12 | — | — | 16C | 17C | 19C |
| 14 | — | — | 17C | 19C | — |

| CAT. NO. | INSIDE DIAMETER (IN.) | CLEVIS HANGER SIZE (IN.) | LENGTH (IN.) | WT. EACH (LBS.) |
|-----------|-----------------------|--------------------------|--------------|-----------------|
| C-790-1A | 2 3/8 | 2 | 12 | .62 |
| C-790-2A | 2 7/8 | 2 1/2 | 12 | .76 |
| C-790-3A | 3 1/2 | 3 | 12 | .92 |
| C-790-4A | 4 | 3 1/2 | 12 | 1.04 |
| C-790-5A | 4 1/2 | 4 | 12 | 1.16 |
| C-790-6A | 5 | 5 | 12 | 1.32 |
| C-790-7A | 5 5/8 | 5 | 12 | 1.46 |
| C-790-8A | 6 5/8 | 6 | 12 | 1.58 |
| C-790-9A | 7 5/8 | 7 | 12 | 1.74 |
| C-790-10A | 8 5/8 | 8 | 12 | 2.02 |
| C-790-11B | 9 5/8 | 10 | 12 | 2.28 |
| C-790-12B | 10 3/4 | 10 | 12 | 2.54 |
| C-790-13C | 11 3/4 | 12 | 12 | 2.84 |
| C-790-14C | 12 3/4 | 12 | 12 | 4.18 |
| C-790-15C | 14 | 14 | 12 | 4.58 |
| C-790-16C | 15 | 16 | 12 | 4.90 |
| C-790-17C | 16 | 16 | 12 | 5.20 |
| C-790-18C | 17 | 18 | 12 | 5.53 |

Standard Finish – GoldGalv®, unless otherwise stated.

M-117 — Eye Socket

Designed for attaching a rod to split ring type clamps. M-117 is only available in 1/4", 3/8" and 1/2" rod sizes.

- Specifications**
- Material: Malleable Iron
 - Compliance: Federal Specification WW-H-171E Type 16, MSS-SP-69 (Type 16)
 - Finish: Plain, Copper
 - Ordering: Specify rod size and catalog number

| CAT. NO. | ROD SIZE A (IN.) | MAX LOAD (LBS.) | MAX B (IN.) | E (IN.) | WT. EACH (LBS.) |
|-----------|------------------|-----------------|-------------|---------|-----------------|
| M-117-1/4 | 1/4 | 240 | 1/4 | 1 5/8 | .08 |
| M-117-3/8 | 3/8 | 610 | 1/4 | 1 5/8 | .08 |
| M-117-1/2 | 1/2 | 1,000 | 1/4 | 1 15/16 | .11 |
| M-117-5/8 | 5/8 | 1,400 | 3/8 | 1 3/4 | .22 |
| M-117-3/4 | 3/4 | 2,200 | 1/2 | 2 1/4 | .30 |
| M-117-7/8 | 7/8 | 2,300 | 1/2 | 2 15/16 | .32 |

Standard Finish – GoldGalv®, unless otherwise stated.

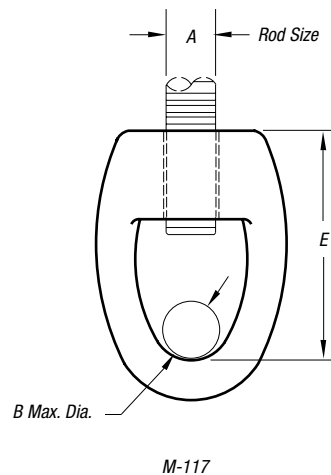

Pipe Straps, Conduit Clamps and Hangers

Rods and Rod Attachments

Shield Size Selection Table

| CAT. NO. | PIPE SIZES | D | F | 1 | 1D | 2 |
|--------------------------------------|------------|-----|----|-----|-----|-----|
| <i>Insulation Thickness (Inches)</i> | | | | | | |
| C-790-1/2 | 1/2 | 1A* | 1A | — | — | — |
| C-790-3/4 | 3/4 | 1A | 1A | 2A | 4A | 6A |
| C-790-1 | 1 | 1A | 2A | 3A | 5A | 7A |
| C-790-1-1/4 | 1 1/4 | 2A | 3A | 4A | 6A | 7A |
| C-790-1-1/2 | 1 1/2 | 2A | 3A | 4A | 6A | 7A |
| C-790-2 | 2 | 3A | 4A | 5A | 7A | 8A |
| C-790-2-1/2 | 2 1/2 | 4A | 5A | 6A | 7A | 8A |
| C-790-3 | 3 | 5A | 6A | 7A | 8A | 9A |
| C-790-3-1/2 | 3 1/2 | — | — | 8A | 9A | 10A |
| C-790-4 | 4 | — | — | 8A | 9A | 10A |
| C-790-5 | 5 | — | — | 9B | 10B | 11B |
| C-790-6 | 6 | — | — | 10B | 11B | 12B |
| C-790-8 | 8 | — | — | — | 13C | 14C |
| C-790-10 | 10 | — | — | 14C | 15C | 16C |
| C-790-12 | 12 | — | — | 16C | 17C | 18C |
| C-790-14 | 14 | — | — | 17C | 18C | — |

*For Unarco foam, specify X1A

Sizes of CL-710 or C-710 Clevis

| PIPE SIZES | 1/2 | 3/4 | 1 | 1 1/2 | 2 |
|--|-------|-------|-------|-------|----|
| <i>For Use with Shields Outside of Insulation. Insulation Thickness (Inches)</i> | | | | | |
| 1/2 | 2 | 2 | — | — | — |
| 3/4 | 2 | 2 | 2 1/2 | 3 1/2 | 5 |
| 1 | 2 | 2 1/2 | 3 | 4 | 5 |
| 1 1/4 | 2 1/2 | 3 | 3 | 5 | 5 |
| 1 1/2 | 2 1/2 | 3 | 3 1/2 | 5 | 5 |
| 2 | 3 | 3 1/2 | 4 | 5 | 6 |
| 2 1/2 | 3 1/2 | 4 | 5 | 5 | 6 |
| 3 | 4 | 5 | 5 | 6 | 8 |
| 3 1/2 | — | — | 6 | 8 | 8 |
| 4 | — | — | 6 | 8 | 8 |
| 5 | — | — | 8 | 8 | 10 |
| 6 | — | — | 8 | 10 | 10 |
| 8 | — | — | — | 12 | 12 |
| 10 | — | — | 12 | — | — |

E-151 — Lag Rod

Designed for a vertical rod connection to wood.

Specifications

- Material: Carbon Steel
- Finish: Standard Finish – GoldGalv®, Black (add suffix “-B”), Electro-Galvanized (add suffix “-EG”)
- Ordering: Specify rod diameter, rod length, catalog number and finish

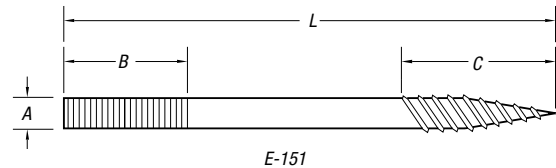

| CAT. NO. | ROD SIZE (IN.) | MAX LOAD (LBS.) | MIN. LENGTH (IN.) | | WT. EACH (LBS.) LENGTH — DIMENSION L | | | | |
|-----------|----------------|-----------------|-------------------|---------|---|-----|-----|-----|-----|
| | | | MACHINE B | COACH C | 4 | 6 | 8 | 10 | 12 |
| E-151-3/8 | 3/8 | 390 | 2 1/2 | 2 | .12 | .19 | .25 | .31 | .37 |
| E-151-1/2 | 1/2 | 640 | 2 1/2 | 2 | .22 | .34 | .44 | .56 | .67 |
| E-151-5/8 | 5/8 | 750 | 2 1/2 | 2 1/2 | .35 | .53 | .70 | .87 | .99 |

Standard Finish – GoldGalv®, unless otherwise stated

Pipe Straps, Conduit Clamps and Hangers

E-157 — Machine Thread Eye Rod

Welded Eyerods are designed to permit swing in the attachment component due to pipe movement.

Specifications

- Material: Carbon Steel. Larger rod diameters over 2 1/2", special materials and special eye dimensions can be furnished upon request
- Finish: Standard Finish – GoldGalv®, Black (add suffix "-B"), Electro-Galvanized (add suffix "-EG")
- Ordering: Specify catalog number, finish, rod size, rod length and thread length if other than standard

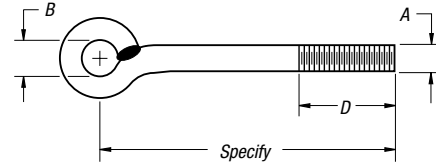

E-157

| A (IN.) | 3/8 | 1/2 | 3/4 | 1 | 1 1/4 | 1 1/2 | 1 3/4 | 2 | 2 1/4 | 2 1/2 | 3 | 3 1/4 |
|---------------------------------|-----|-------|-------|-------|-------|-------|-------|--------|--------|--------|--------|--------|
| B (IN.) | 3/4 | 7/8 | 1 | 1 1/8 | 1 1/4 | 1 3/8 | 1 1/2 | 1 3/4 | 2 | 2 1/4 | 2 3/4 | 3 1/4 |
| Thread | 3 | 3 | 3 | 3 | 4 | 4 | 4 | 6 | 6 | 6 | 6 | 6 |
| Length D (IN.) | | | | | | | | | | | | |
| Load at (LBS.) 650° F/343° C | 610 | 1,130 | 1,810 | 2,710 | 3,770 | 4,960 | 8,000 | 11,630 | 15,700 | 20,700 | 27,200 | 33,500 |
| Load at (LBS.) 750° F/399° C | 540 | 1,010 | 1,610 | 2,420 | 3,360 | 4,420 | 7,140 | 10,370 | 14,000 | 18,460 | 24,260 | 29,880 |

Standard Finish – GoldGalv®, unless otherwise stated

Pipe Straps, Conduit Clamps and Hangers

F-111 — Forged Steel Clevis

Used to connect rod ends with structural steel welding lug plates or lugs welded to pipe. It provides a pivot point and adjustment. It can be supplied with a pin as F-111.

Specifications

- Material: Forged Steel
- Compliance: Federal Specification A-A-1192A Type 14, MSS-SP 69 Type 14 and BSPSS-BS3974
- Finish: Standard Finish – GoldGalv®, Black (add suffix “-B”), Electro-Galvanized (add suffix “-EG”)
- Ordering: Specify catalog number, rod size, pin size, grip “G” and finish

| CAT. NO. | ROD SIZE | MAX. LOAD 650° F/343° C | PIN/BOLT DIA. | SIZE NO. | P | WT. EACH (LBS.) |
|-------------|----------|----------------------------|---------------|----------|-------|-----------------|
| F-111-3/8 | 3/8 | 610 | 1/2 | 2 | 3/16 | .77 |
| F-111-1/2 | 1/2 | 1,130 | 3/8 | 2 | 1/16 | .77 |
| F-111-5/8 | 5/8 | 1,810 | 3/4 | 2 | 1/16 | .77 |
| F-111-3/4 | 3/4 | 2,710 | 7/8 | 2 1/2 | 1 | 2.50 |
| F-111-7/8 | 7/8 | 3,770 | 1 | 2 1/2 | 1 1/8 | 2.50 |
| F-111-1 | 1 | 4,960 | 1 1/8 | 3 | 1 1/4 | 4.00 |
| F-111-1-1/4 | 1 1/4 | 8,000 | 1 3/8 | 3 | 1 1/2 | 4.00 |
| F-111-1-1/2 | 1 1/2 | 11,630 | 1 3/8 | 3 1/2 | 1 3/4 | 6.00 |
| F-111-1-3/4 | 1 3/4 | 15,700 | 1 3/8 | 4 | 2 | 8.00 |
| F-111-2 | 2 | 20,700 | 2 1/4 | 5 | 2 3/8 | 16.00 |
| F-111-2-1/4 | 2 1/4 | 27,200 | 2 1/2 | 6 | 2 3/8 | 26.00 |
| F-111-2-1/2 | 2 1/2 | 33,500 | 2 3/4 | 6 | 2 3/8 | 36.00 |

Standard Finish – GoldGalv®, unless otherwise stated

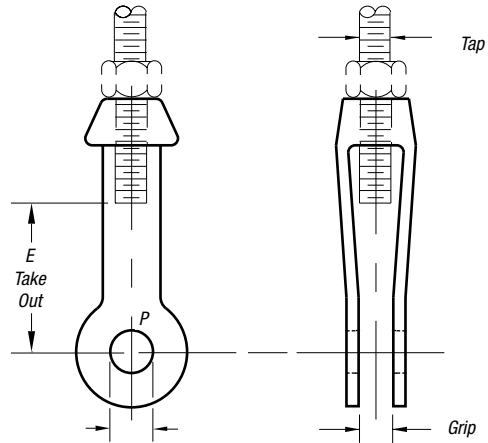

F-111

Note: Pins and Cotter Pins supplied when requested as Fig. F-111.

E-120-A — Forged Weldless Eyenut

Used to connect rod ends with structural steel welded beam attachments or pipe clamps as a substitute for a welded eyerod. It provides a pivot point and adjustment. It can also be supplied tapped left hand as E-120-A.

Specifications

- Material: Forged Steel
- Compliance: Federal Specification A-A-1192A Type 14, MSS-SP 69 Type 14 and BSPSS-BS3974
- Finish: Standard Finish – GoldGalv®, Black (add suffix “-B”), Electro-Galvanized (add suffix “-EG”)
- Ordering: Specify catalog number, rod size and finish

| CAT. NO. | ROD TAP A | MAX. LOAD 650° F/343° C | F | WT. EACH (LBS.) |
|---------------|--------------|----------------------------|-------|-----------------|
| E-120-A-3/8 | 3/8 | 610 | 1 | .20 |
| E-120-A-1/2 | 1/2 | 1,130 | 1 | .31 |
| E-120-A-5/8 | 5/8 | 1,810 | 1 | .55 |
| E-120-A-3/4 | 3/4 | 2,710 | 1 | 1.00 |
| E-120-A-7/8 | 7/8 | 3,770 | 1 1/8 | 1.55 |
| E-120-A-1 | 1 | 4,960 | 1 1/4 | 2.45 |
| E-120-A-1-1/4 | 1 1/4 | 8,000 | 1 3/4 | 3.75 |
| E-120-A-1-1/2 | 1 1/2 | 11,630 | 1 3/4 | 6.75 |
| E-120-A-1-3/4 | 1 3/4 | 15,700 | 3 1/4 | 16.40 |
| E-120-A-2 | 2 | 20,700 | 3 1/4 | 16.75 |
| E-120-A-2-1/4 | 2 1/4 | 27,200 | 3 1/4 | 16.75 |
| E-120-A-2-1/2 | 2 1/2 | 33,500 | 3 1/4 | 16.75 |

Standard Finish – GoldGalv®, unless otherwise stated

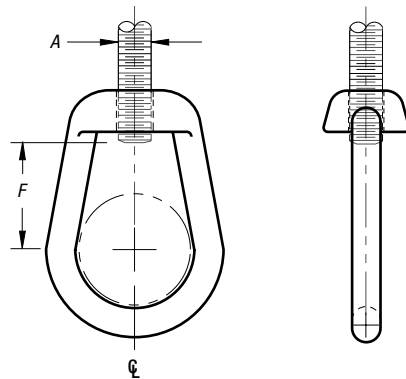

E-120-A

Surface Raceway and Lighting Systems

Electrical Raceway

Series 800 Surface Raceway and Lighting Systems

Superstrut® channel together with snap-in closure strip is listed by Underwriters Laboratories as a surface metal raceway. Other accessories listed by Underwriters Laboratories are identified on the drawings.

Electrical Applications

Column A

Suitable for number of wires indicated when used as a raceway. Also suitable for number of wires indicated when installed to support and supply electric discharge type fixtures when raceway wiring is suitable for not less than 75° C.

Column B

Suitable for number of wires indicated when used as a raceway. Also suitable for number of wires indicated when installed to support electric discharge type fixtures when clearance of not less than 1/8" is provided between raceway and fixture and when wiring is suitable for 75° C.

GoldGalv® hardware finish is standard for all Superstrut® products. This is a multi-process finish of electro-plated zinc, followed by gold-colored trivalent chromium coating to give excellent corrosion resistance and a superior paint base. See **pages B-106-B-107** for a complete description of the GoldGalv® hardware finish. GoldGalv® hardware finish will be furnished if no other finish is specified.

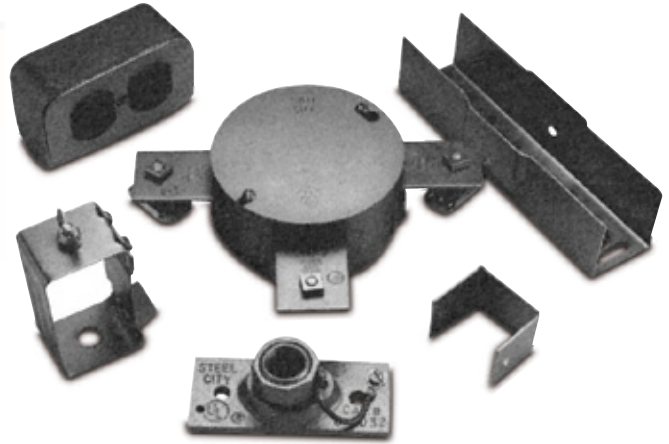

Materials:

Superstrut® electrical raceway, fixture hanging channel, closure strip and accessories are cold formed from hot-rolled strip steel.

Design Data:

Deflections at various hanger rod spacings for raceway channels, based on 40 to 45 lbs. per fixture.

UL LISTED CHANNELS

| | |
|-----------|---------|
| A-1200 | B-1200 |
| A-1200-KO | B1200AL |
| A-1200 AL | B-1400 |
| A-1200 PG | C-1200 |
| A-1400 | E-1200 |
| A-1400-KO | H-1200 |
| A-1400 SS | |

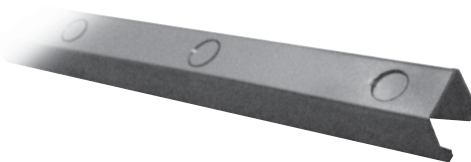

| CHANNEL | DEFLECTION AT | | |
|---------|---------------|--------|-----------|
| | AT 10 FT. | 12 FT. | AT 14 FT. |
| A-1200 | 1/4" | 1/2" | 3/4" |
| C-1200 | 3/8" | 3/4" | * |
| A-1400 | 3/8" | 3/4" | * |

| CHANNEL | DEFLECTION CHANNEL AT 7 FT. | | |
|---------|-----------------------------|----------|----------|
| | AT 6 FT. | AT 7 FT. | AT 9 FT. |
| B-1200 | 3/8" | 9/16" | 5/8" |
| B-1400 | 1" | 1/2" | * |

*Not recommended for this spacing

Maximum Number of Wires

| AVG | RACEWAY WITH OR WITHOUT KO | | | | | | | |
|-----|----------------------------|----|------------------|---|--------|----|------------------|----|
| | A-1200 A-1400 | | B-1200 B-1400 | | C-1200 | | E-1200 H-1200 | |
| | A | B | A | B | A | B | A | B |
| 14 | 6 | 10 | 4 | 6 | 5 | 10 | 6 | 10 |
| 12 | 6 | 10 | 3 | 6 | 4 | 10 | 6 | 10 |
| 10 | 5 | 8 | — | — | 4 | 6 | 5 | 8 |
| 8 | 4 | 6 | — | — | 3 | 4 | 4 | 6 |
| 6 | 2 | 3 | — | — | 2 | 2 | 2 | 3 |

Surface Raceway and Lighting Systems

Electrical Applications (continued)

Metal Framing & Cable Tray — Superstrut® Metal Framing System

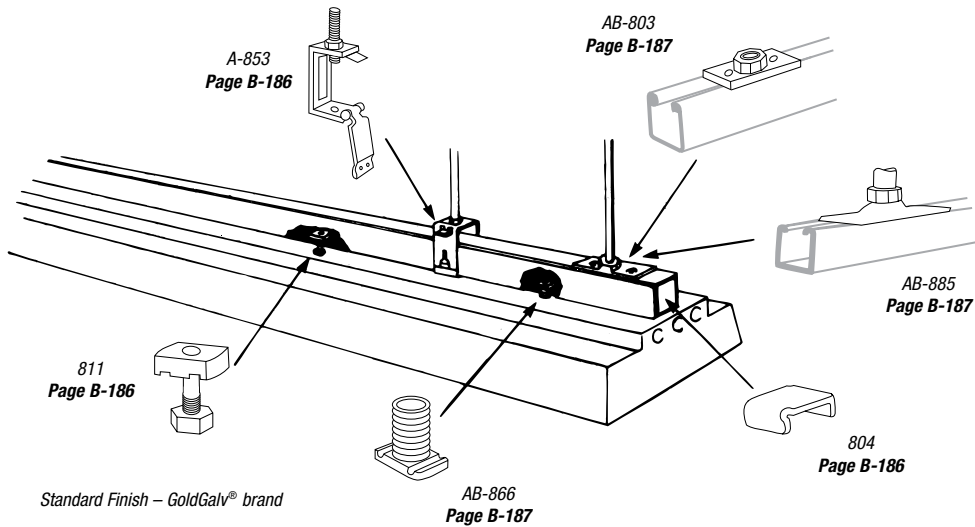
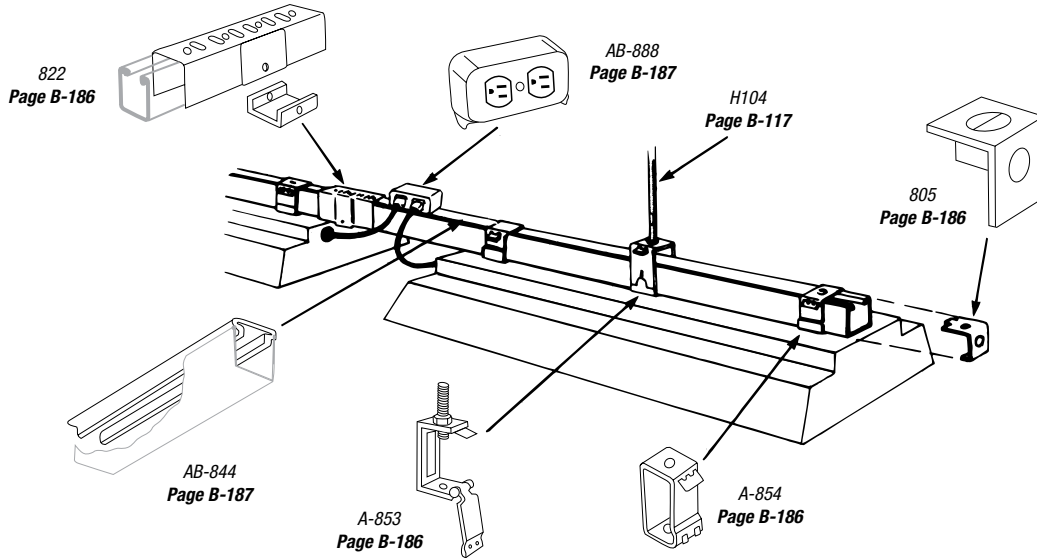

Surface Raceway and Lighting Systems

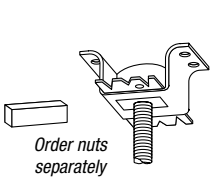
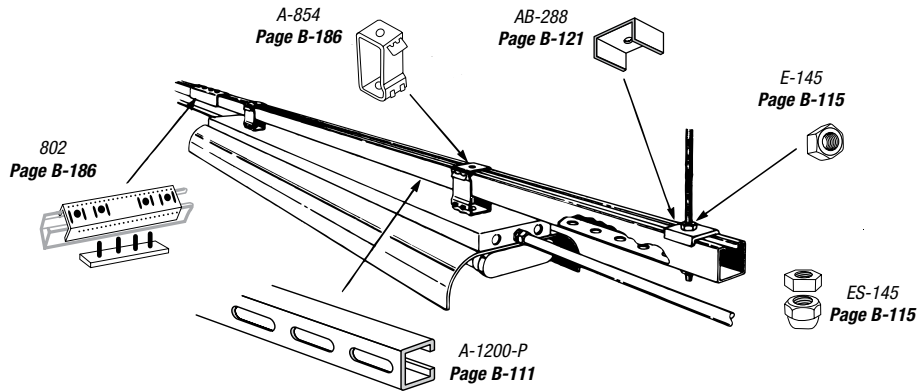
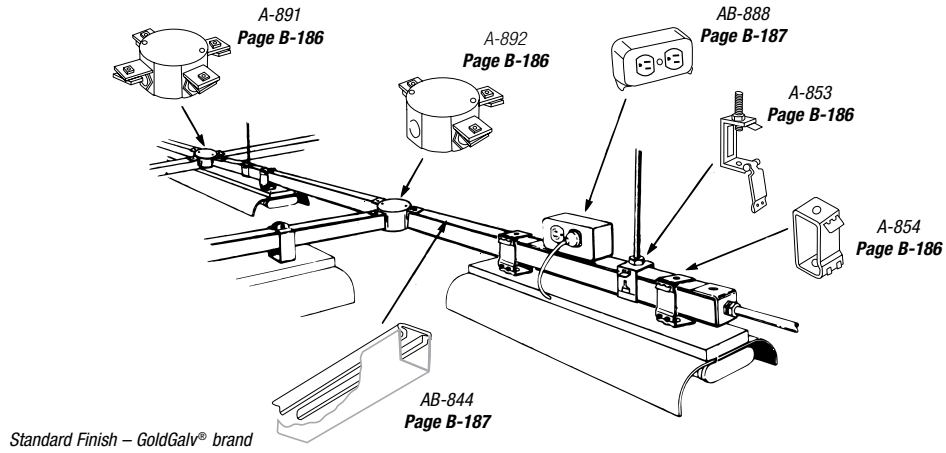

452TB
Concrete Spot Insert
Page B-127

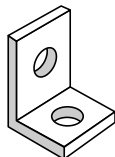

540
Side Beam
Hanger Clip
Page B-130

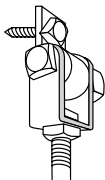

S-541
Swing Connector
Page B-131

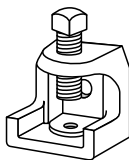

500
Beam Clamp
Page B-130

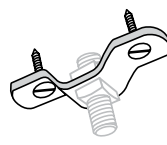

U-579
Ceiling Flange
Page B-50

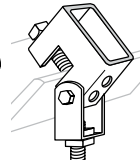

US-563
Beam Clamp
Page B-130

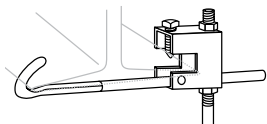

U-569
Beam Clamp
with Safety Rod
Page B-133

Surface Raceway and Lighting Systems

Fixture Fittings

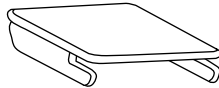

A-243-1
End Cap for A-1200 Channel

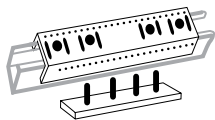
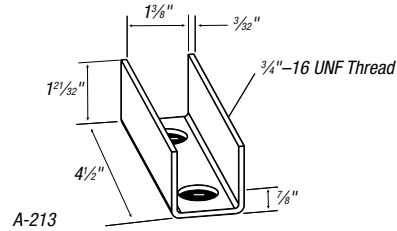

802
Raceway Joiner with Reinforcing Plate
furnished complete with nuts.

| CAT. NO. | FOR CHANNEL | STD. CTN. |
|----------|-------------|-----------|
| A802 | A Series | 25 |
| B-802 | B Series | 25 |
| E-802 | E Series | 10 |
| H-802 | H Series | 10 |

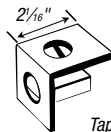

809
Tapped End Cap

12 ga for 3/4" or 1" Conduit.
Furnished complete with 1/4" x 5/8"
Flat Head Machine Screw and
AB-100-1/4 nut.

| CAT. NO. | FOR CHANNEL | STD. CTN. |
|----------|-------------|-----------|
| A-809 | A Series | 25 |
| H-809 | H Series | 25 |

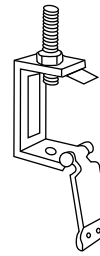

A853
Channel Hanger
Use hanger rod 3/8" or 1/2".
Use with "A", "B" or "C" series
single channel.

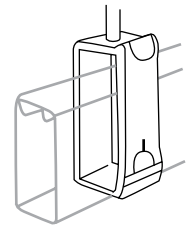

A853L
Channel Hanger
Long type for all
series channel.



804
End Cap

| CAT. NO. | FOR CHANNEL | STD. CTN. |
|----------|-------------|-----------|
| A804 | A-1200 | 25 |
| | A-1400 | 25 |
| B804 | B-1400 | 25 |
| C-804 | C-1200 | 25 |
| E-804 | E-1200 | 25 |
| H-804 | H-1200 | 25 |

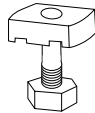

811
Stud Nut

For attaching fixture to Slot Down
Channel or to Slot up Knockouts.
Specific length. Hex Nut included.

| CAT. NO. | FOR CHANNEL | STD. CTN. |
|-----------|-------------|-----------|
| 811 1-STR | 1/4 x 1 | 50 |
| 811-2STR | 1/4 x 1 1/4 | 50 |

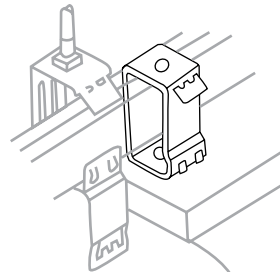

A854
Channel Hanger
Illustration showing A-854 with nut and bolt
furnished to attach to fluorescent fixture.
Use with "A", "B" or "C" series channel.

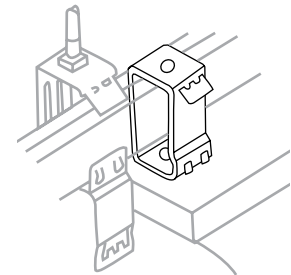

A854L
Channel Hanger
Long Illustration showing A-854-L
with nut and bolt furnished to attach
to fluorescent fixture. Long
type for all series channel.

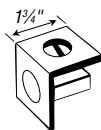

805
End Cap with Knockout

KO for 1/2" conduit. Furnished
complete with 1/4" x 5/8" flat Head
Machine Screw and AB-100-1/4 nut.

| CAT. NO. | FOR CHANNEL | STD. CTN. |
|----------|-------------|-----------|
| A-805 | A Series | 25 |
| H-805 | H Series | 25 |

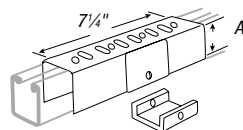

822
Raceway Joiner & Seal

| CAT. NO. | A (IN.) | FOR CHANNEL | STD. CTN. |
|----------|---------|-------------|-----------|
| A822* | 1 1/16 | A Series | 25 |
| B-822* | 7/8 | B Series | 25 |
| C-822* | 1 1/16 | C Series | 25 |

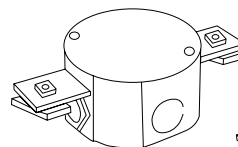

A889*

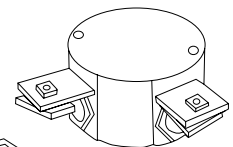

A890*

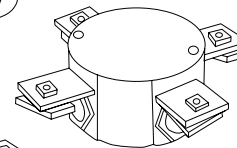

A891*

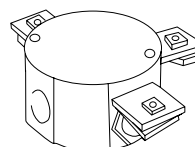

A892*

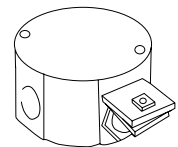

A893



Surface Raceway and Lighting Systems

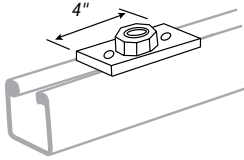

AB803*
Cast Conduit Connector
To connect 1/2" or 3/4" conduit to raceway channel — Furnished complete with stud nuts & hex nuts. Part has removable bushing to increase size from 1/2" to 3/4".

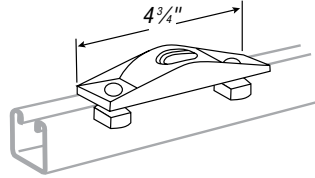

AB815
Swing Connector
Nuts & bolts to clamp to channel included. For 1/2" or 3/4" conduit.

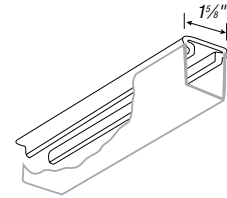

AB-844* Steel Closure Strip
AB-844-PC* Plastic Closure Strip
When used as a raceway channel, it is normally installed with the slot up and after wiring is complete, the closure strip is installed. For all channels. Standard lengths 10 ft.

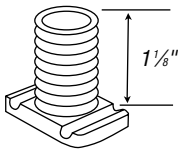

AB-866
1/2" Pipe thread

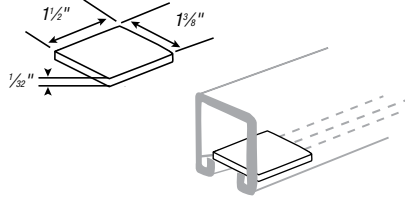

AB868
Fiber Retainer for cables until closure strip is installed.

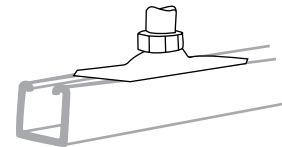

AB885
15° Swivel
Nuts and bolts to clamp to channel included. For 1/2" or 3/4" conduit.

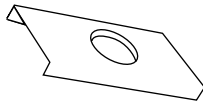

AB867*
Spacer Clevis
For use with AB-866 wiring stud nuts.

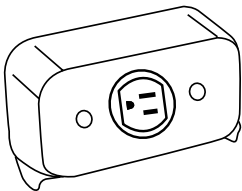

AB887*
Single Outlet
Complete unit including housing, standard SINGLE 3-wire, 15 Amp, 125 Volt, NEMA ground receptacle and cover plate.

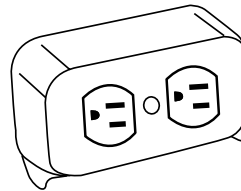
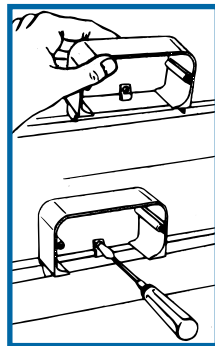

AB888*
Duplex Outlet
Complete unit including housing, standard DUPLEX 3-wire, 15 Amp, 125 Volt, NEMA ground receptacle and cover plate.

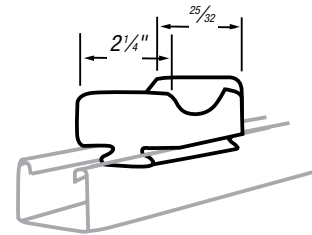

AB-880 AB-881
3" and 4" Porcelain Saddles

| CAT. NO. | MAX. CABLE DIAM. (IN.) | STD. CTN. |
|----------|------------------------|-----------|
| AB-880 | 3 | 3 |
| AB-881 | 4 | 4 1/2 |

Slotted Angle Metal Framing

With Superangle, You Get Flexibility
— Simplicity — Economy!

Superangle Slotted Angle Metal Framing

Create the support framing you need.

Superangle is manufactured from structural-quality steel in three different sizes. The small sizes are 14 ga. steel, the larger size is 12 ga. steel. With this offering, an endless variety of metal framing requirements can be met, from lightweight supporting needs to larger shelving needs such as inventory storage.

One of the legs on all sizes is 1 5/8" wide, while the other is either 1 5/8", 2 3/8" or 3 1/2" long. Depending on the frame requirements, a single size can be utilized throughout, or the sizes can be interchanged to get the most efficient usage from the material.

Installation time is reduced — inventory space is minimal.

Scribe marks are placed every 3/4", which saves planning, layout and cutting time and provides accuracy. The exclusive slot and hole pattern, repeated every 3", is scientifically designed for ease of assembly. The proper nuts and bolts are included with the material to ensure fast and easy erection.

Superangle Metal Framing is packaged in 10' and 12' lengths to minimize cutoffs and ensure maximum use of material.

10', 12' lengths of Superangle take up the same amount of space as one 2 x 4. A standard package includes five pieces to a bundle, therefore handling and storage space are significantly reduced.

The importance of cutting Superangle easily, quickly and accurately is the key to time-saving assembly. The Portable Cutter provides these advantages and makes layout and erection of any structure a light-work job.

Finish is designed for long lasting durability.

The standard GoldGalv® hardware finish is applied to all Superangle products after rolling and punching of the holes. This provides you with a number of benefits. First, raw ends resulting from cuts will be protected by the sacrificial quality of zinc. Second, the edges of all holes are protected against formation of rust, to provide a call-back free installation. Third, the electro-galvanizing process provides an excellent bonding surface for paint if desired for aesthetic reasons.

Note: Product is also available with Pre-Galvanized (PG) sections

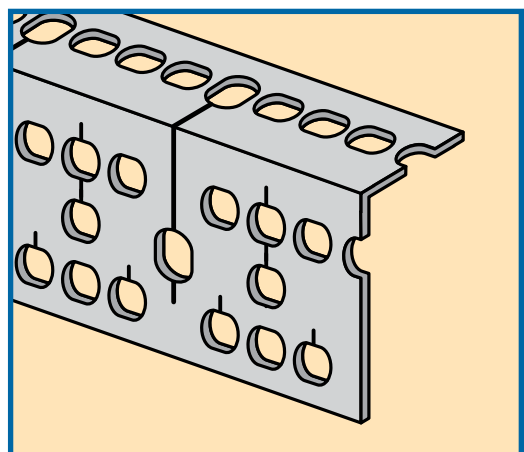
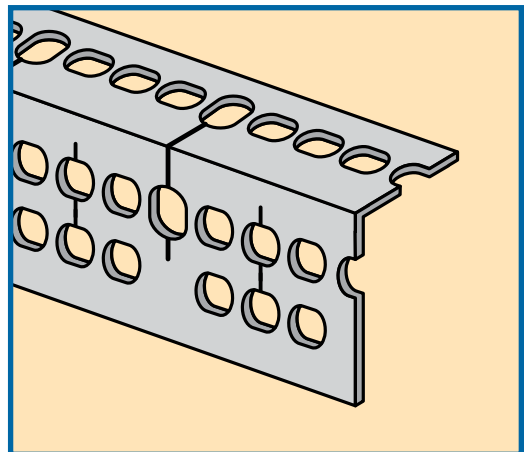
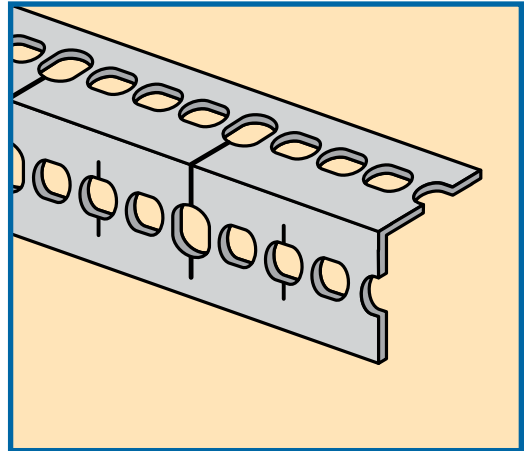

Slotted Angle Metal Framing

Superangle Slotted Angle Metal Framing (continued)

| CAT. NO. | LENGTH (FT.) | FT. PER PKG. | STD. CTN. |
|-----------|--------------|--------------|-----------|
| RA-160-10 | 10 | 50 | 1,000 |
| RA-160-12 | 12 | 60 | 1,200 |
| RA-225-10 | 10 | 50 | 1,000 |
| RA-225-12 | 12 | 60 | 1,200 |
| RA 300 10 | 10 | 50 | 1,000 |
| RA-300-12 | 12 | 60 | 1,200 |

5 Lengths, 36 Nuts and Bolts

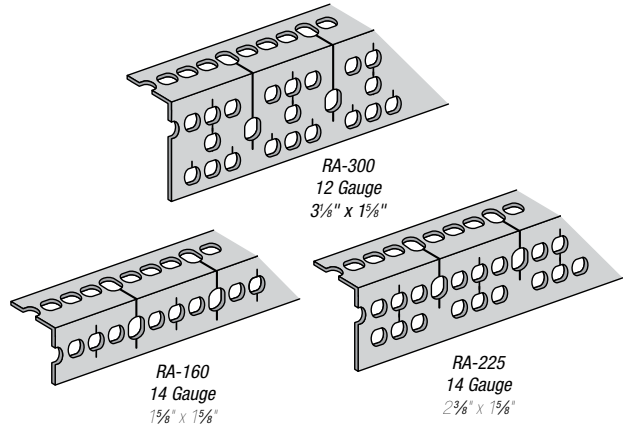

Superangle Accessories

Casters

| CAT. NO. | STD. PKG. | STD. CTN. |
|----------|-----------|-----------|
| RA RC | 2 | 2 |
| RA SC | 2 | 2 |



RA-RC
Rigid Center



RA-SC
Swivel Caster

Rigid & Swivel Casters
Hard rubber composition 3 1/2" dia.
with load rating of 225 lbs. per wheel.

Portable Cutter

| CAT. NO. | STD. PKG. | STD. CTN. |
|----------|-----------|-----------|
| RA C | 1 | 1 |

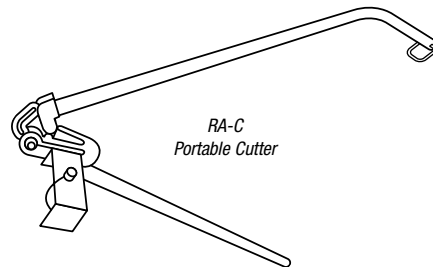

RA-C
Portable Cutter

Gusset Plate

| CAT. NO. | STD. PKG. | STD. CTN. |
|----------|-----------|-----------|
| RA GP | 25 | 100 |

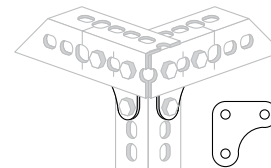

RA-GP
Gusset Plate
for extra-rigid
assembly.

Extra Nuts and Bolts

| CAT. NO. | PACKAGE 100 SETS | STD. CTN. |
|--------------------------|--------------------|-----------|
| RA BN 5/8 | 3/8"-16 x 3/4" lg. | 100 |
| Use with RA-160 & RA-225 | | |
| RA BN 3/4 | 3/8"-16 x 3/4" lg. | 100 |
| Use with RA-300 | | |

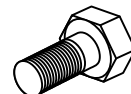
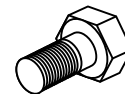

Extra Nuts and Bolts

Special Metals and Finishes

Properties for Design — Stainless Steel (Suffix SS/Type 304 and 6SS/Type 316)

Superstrut® stainless steel products are made from high-quality austenitic Type 304 and Type 316 material. Stainless steel contains large amounts of chromium and nickel, is non magnetic and offers superior corrosion resistance. Tolerant to high-temperature environments, Superstrut's stainless steel framing provides dependable support, resulting in reduced maintenance cost. The channel is roll-formed to shape when cold, enhancing its structural strength for the most rigid of applications.

Stainless Steel Channel

Elements of sections are the same as shown on **pages B-200–B-210** for standard steel channel. Load ratings meet or exceed ratings for standard steel channel shown elsewhere in this catalog.

Additional stainless steel and aluminum items are available. Contact your local Superstrut® representative.

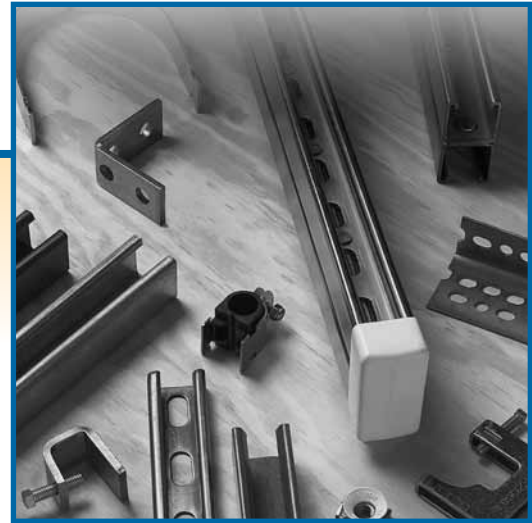

Properties for Design Aluminum Channel (Suffix AL)

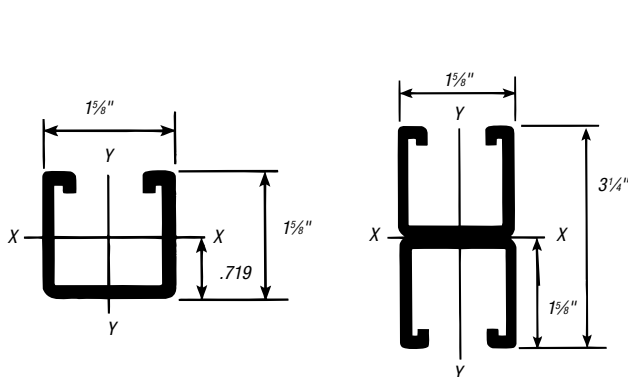

Span (IN.): 12, 18, 24, 30, 36, 42, 48, 54, 60, 72, 84, 96, 108 & 120.

12 ga. = .105"

I — Moment of Inertia

S — Section of Modulus

r — Radius of Gyration

A — Area

Calculations based on maximum fiber stress of 10,000 psi, maximum 1/360th span deflection. For concentrated loads, multiply load by 0.50.

Specifications

- Alloy and Temper: 6063-T6
- Tensile Strength: Yield — 25,000 PSI
Ultimate — 30,000 PSI
- Shear — Ultimate: 19,000 PSI
- Elongation: (Percent in 2 inches) -12
- Density: .098 Lbs./Cu. Inch
- Modules of Elasticity: 10 x 106 PSI

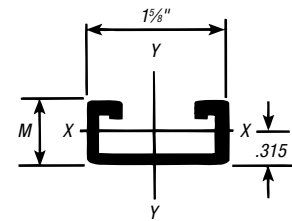

| SECTION MEMBER | X - X AXIS | | | | Y - Y AXIS | | |
|----------------|--------------------|--------------------|--------------------|-------|--------------------|--------------------|-------|
| | A IN. ² | I IN. ⁴ | S IN. ³ | R IN. | I IN. ⁴ | S IN. ³ | R IN. |
| A-1200 | .563 | .198 | .224 | .594 | .274 | .338 | .698 |
| B-1200 | .400 | .041 | .082 | .320 | .150 | .185 | .612 |
| A-1202 | 1.126 | 1.001 | .620 | .942 | .548 | .676 | .698 |

Safe Uniform Total Load Table (X-X AXIS)

| SPAN (IN.) | B-1200-AL (LBS.) | A-1200-AL (LBS.) | A-1202-AL (LBS.) |
|------------|------------------|------------------|------------------|
| 12 | 540 | 1,490 | 4,130 |
| 18 | 270 | 990 | 2,760 |
| 24 | 150 | 730 | 2,070 |
| 30 | 90 | 470 | 1,650 |
| 36 | 60 | 320 | 1,370 |
| 42 | 50 | 240 | 1,180 |
| 48 | — | 180 | 930 |
| 54 | — | 140 | 730 |
| 60 | — | 110 | 590 |
| 72 | — | 80 | 410 |
| 84 | — | 60 | 300 |
| 96 | — | 40 | 230 |
| 108 | — | 30 | 180 |
| 120 | — | 20 | 140 |

Special Metals and Finishes

Aluminum Products (AL Suffix)

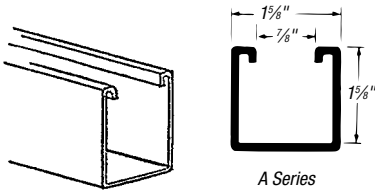

A Series

A-1200_AL

1 5/8" deep channel and combination

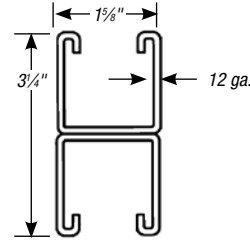

A-1202_AL

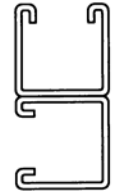

A-1202-C_AL

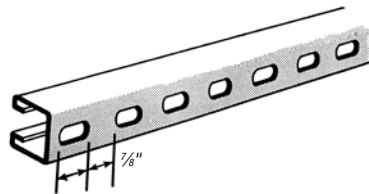

A-1200-HS_AL
Slots 2" on center.
Slot size 3/16" x 1 1/8"

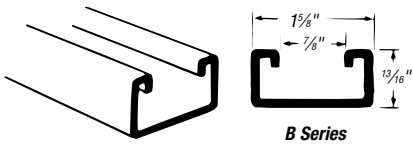

B Series

B-1200_AL

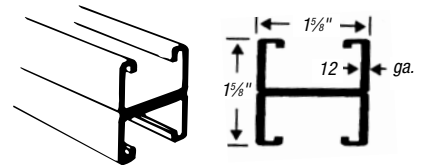

B-1202_AL

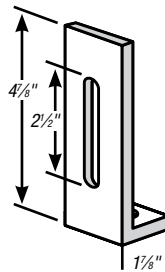

X201_AL

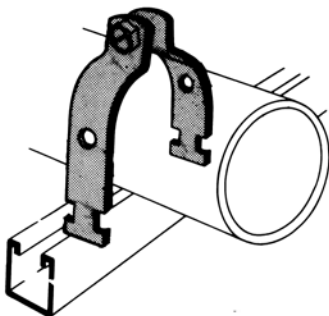

702_AL
Rigid Conduit Pipe Strap

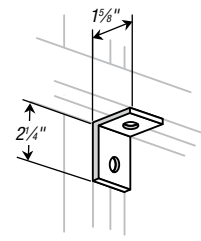

AB201_AL

Special Metals and Finishes

Stainless Steel Products

Available in:

- Type 304 Stainless Steel — SS Suffix
- Type 316 Stainless Steel — T316SS Suffix

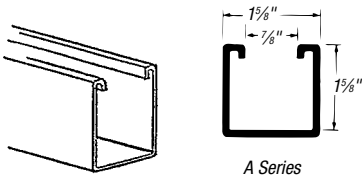

A-1200_SS
A-1200_T316SS

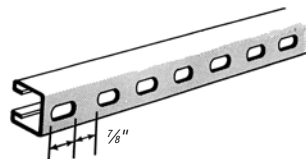

A-1200-HS_SS
A-1200-HS_T316SS



A-1202_SS
A-1202-T316SS

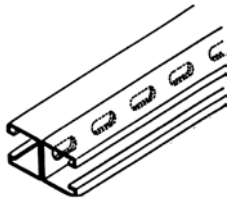

A-1202-HS_SS
A-1202-HS_T316SS

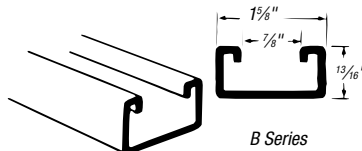

12 gauge
B-1200_SS
B-1200_T316SS
14 gauge
B-1400_SS
B-1400_T316SS

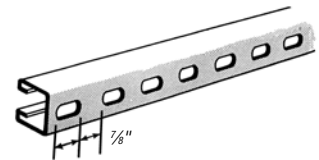

B-1400-HS_SS
B-1400-HS_T316SS

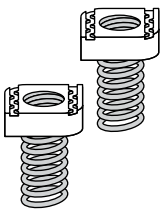

A-100
Regular Spring Nut

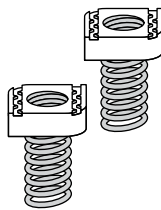

B-100
Short Spring Nut

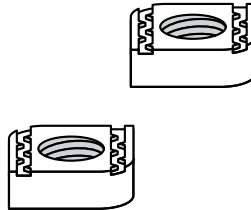

AB-100
Springless Nut

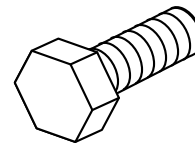

E-142
Hex Head Cap Screw

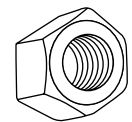

E-145
Standard Hex Nut

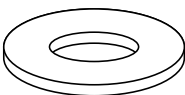

EF-147
Fender Washer



E-147
Flat Steel Washer

AB-241 Square Washer

| CAT. NO. | ROD SIZE (IN.) | STD. CTN. |
|------------|----------------|-----------|
| AB-241-1/4 | 1/4 | 100 |
| AB-241-3/8 | 3/8 | 100 |
| AB-241-1/2 | 1/2 | 100 |

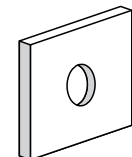

Special Metals and Finishes

Stainless Steel Products (continued)

Available in:

- Type 304 Stainless Steel — SS Suffix
- Type 316 Stainless Steel — SS6 Suffix

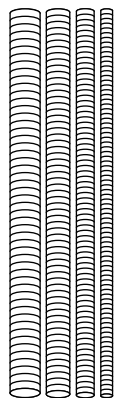
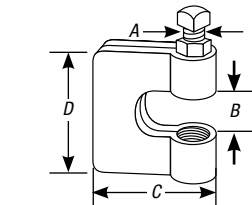
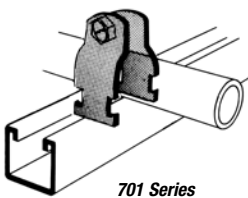
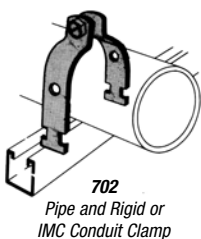
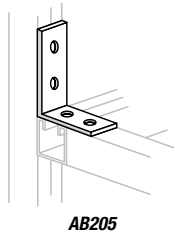
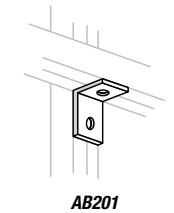
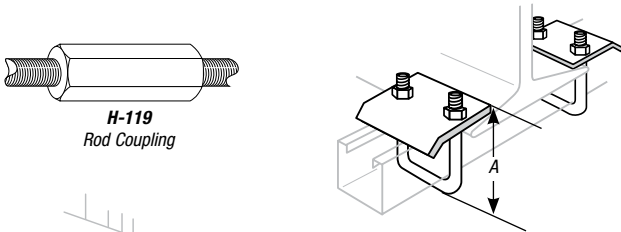

U501, U502

| CAT. NO. | FOR CHANNEL | A (IN.) | STD. CTN. |
|----------|---------------|--------------------------------|-----------|
| U501 | A-1200 A-1400 | 3 ³ / ₁₆ | 20 |
| | B-1200 B-1400 | | |
| | C-1200 B-1402 | | |
| U502 | A-1202 A-1402 | 4 ¹ / ₁₆ | 20 |
| | C-1202 H-1200 | | |

Furnished complete

Design Load U501 — 2150 lbs.

U502 — 3000 lbs.

C-775L — Clamp with Lock Nut

| CAT. NO. | ROD SIZE (IN.) | DIMENSIONS (IN.) | | | | DESIGN LOAD (LBS.) | STD. CTN. |
|----------|----------------|--------------------------------|--------------------------------|--------------------------------|--------------------------------|--------------------|-----------|
| | | A | B | C | D | | |
| C-775L | 3/8 | 3/8 | 3/4 | 2 ³ / ₁₆ | 2 ³ / ₁₆ | 400 | 100 |
| | 1/2 | 2 ³ / ₁₆ | 2 ⁵ / ₁₆ | 2 ⁵ / ₁₆ | 2 ³ / ₁₆ | 500 | 100 |

H-104

- Hanger rod
- Continuous threaded

NATIONAL COARSE THREAD

| CAT. NO. | SIZE (IN.) | THREADS PER INCH | DESIGN LOAD (LBS.) | STD. CTN. |
|-------------|-------------------------------|------------------|--------------------|-----------|
| H-104-1-1/4 | 1 ¹ / ₄ | 20 | 150 | 500 |
| H-104-3/8 | 3/8 | 16 | 610 | 500 |
| H-104-1/2 | 1/2 | 13 | 1,130 | 500 |
| H-104-5/8 | 5/8 | 11 | 1,810 | 500 |
| H-104-3/4 | 3/4 | 10 | 2,710 | 500 |
| H-104-7/8 | 7/8 | 9 | 3,770 | 500 |
| H-104-1 | 1 | 8 | 4,960 | 500 |

Standard lengths 12' only

Cobra® Clamp

| CAT. NO. | FOR EMT AND RIGID CONDUIT | CABLE O.D. RANGE (IN.) | STATIC LOAD LIMIT (LB) | STD. CTN. |
|----------------------------|-------------------------------|------------------------|------------------------|-----------|
| | TRADE SIZE (IN.) | | SAFETY FACTOR = 4 | |
| 316 Stainless Steel | | | | |
| CPC050SS6 | 1/2 | .650-.890 | 200 | 100 |
| CPC075SS6 | 3/4 | .860-1.110 | 200 | 100 |
| CPC100SS6 | 1 | 1.100-1.400 | 200 | 100 |
| CPC125SS6 | 1 ¹ / ₄ | 1.400-1.725 | 200 | 50 |
| CPC150SS6 | 1 ¹ / ₂ | 1.690-1.980 | 200 | 50 |
| CPC200SS6 | 2 | 1.980-2.576 | 200 | 50 |
| CPC250SS6 | 2 ¹ / ₂ | 2.576-3.060 | 350 | 25 |
| CPC300SS6 | 3 | 3.060-3.626 | 350 | 25 |
| CPC350SS6 | 3 ¹ / ₂ | 3.626-4.126 | 350 | 25 |
| CPC400SS6 | 4 | 4.126-4.626 | 350 | 25 |

Special Metals and Finishes

Type 304 Stainless Steel Products (SS Suffix)

Metal Framing & Cable Tray — Superstrut® Metal Framing System

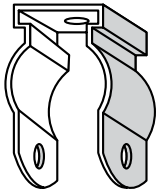

6H Series

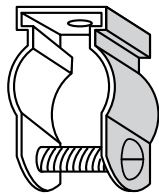

6H-B Series
Conduit and Pipe Hanger

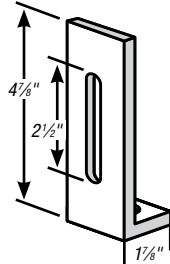

X201

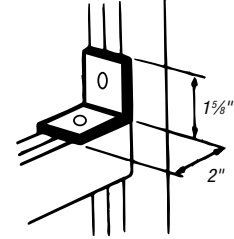

AB202

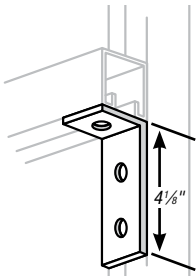

AB203

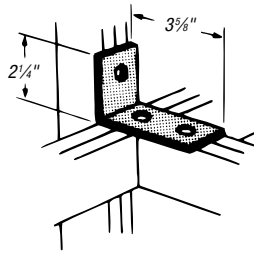

AB204

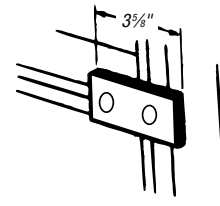

AB206

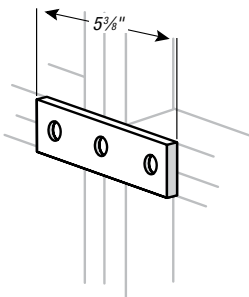

AB207

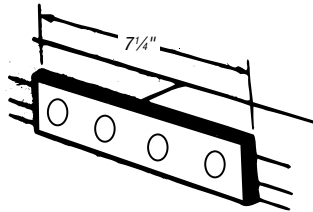

X207

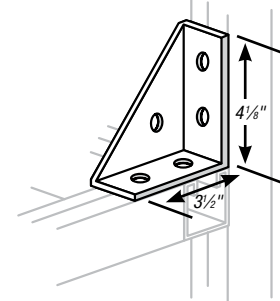

AB213

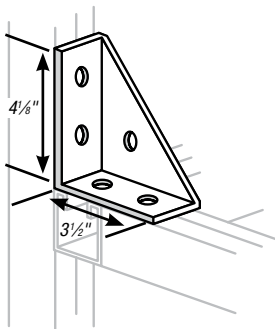

AB214

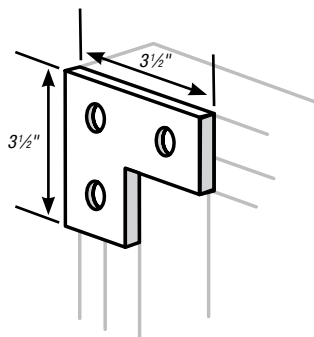

AB219

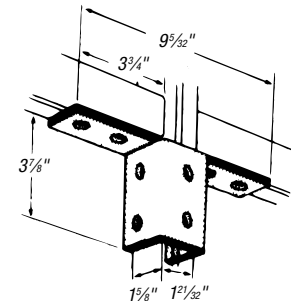

AW219

Special Metals and Finishes

Type 304 Stainless Steel Products (SS Suffix) (continued)

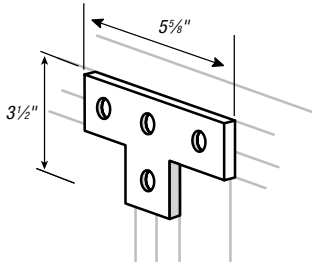

AB220

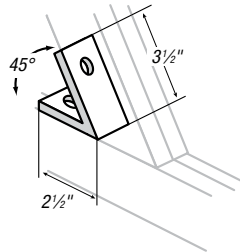

AB225

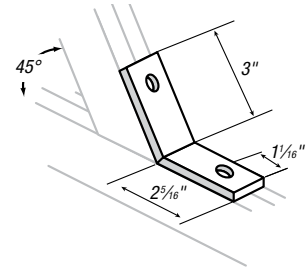

SPAB-227

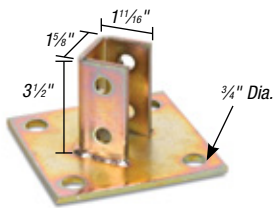

AP-232

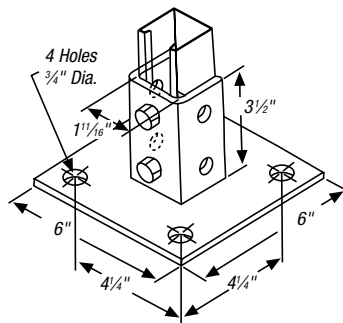

AP-232SQ

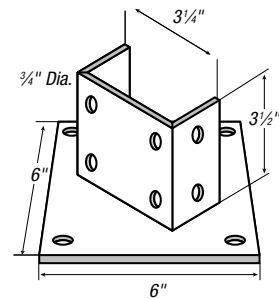

AP-235

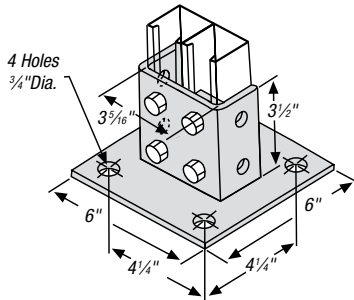

AP-235SQ

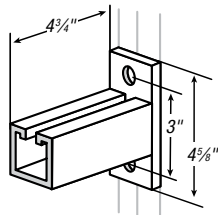

S-250

A is in lengths: 6, 12, 18 & 24.
May be installed inverted with no change
in load ratings. Strut section made from
half slot channel.

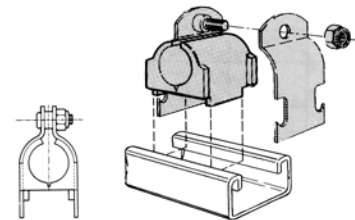

A-716
Cushioned Clamp Tube Series

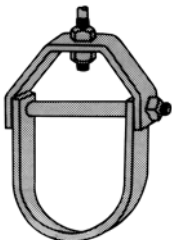

C-710 Series
Standard Clevis

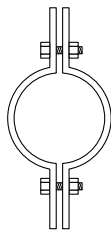

C-720

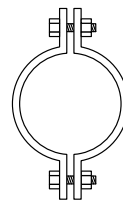

C-725



C-727
Standard Ring Hanger

Special Metals and Finishes

White Painted Products (WH Suffix)

Metal Framing & Cable Tray — Superstrut® Metal Framing System

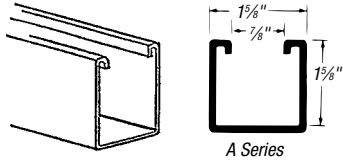

A-1200

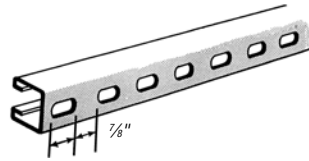

A-1200-HS

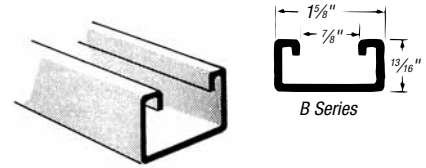

B-1400

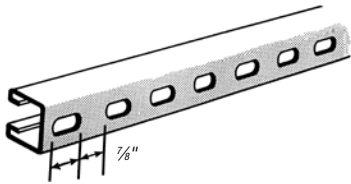

B-1400-HS

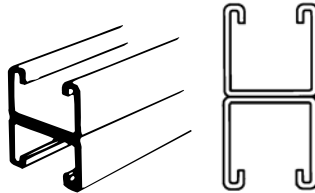

A-1202

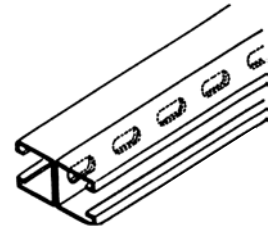

A-1202-HS

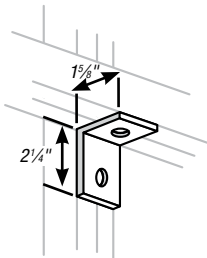

AB201

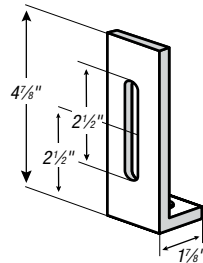

X201

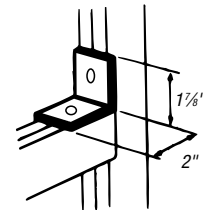

AB219

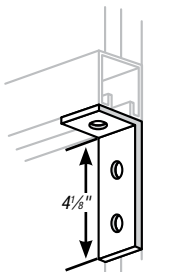

AB203

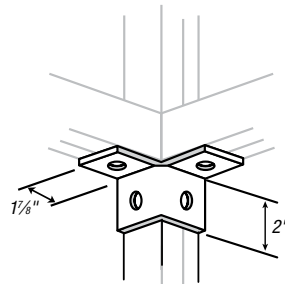

AW204

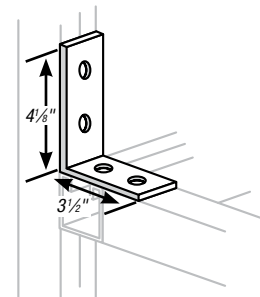

AB205

Special Metals and Finishes

White Painted Products (WH Suffix) (continued)

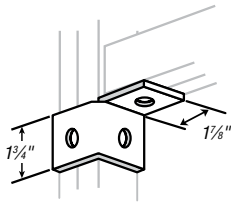

AW205 L

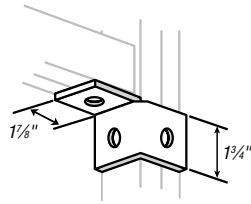

AW-205-R

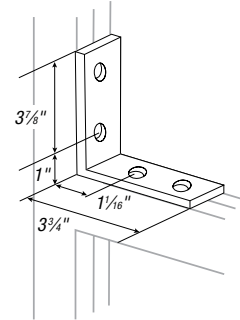

N-205

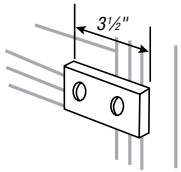

AB-206

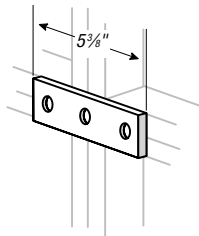

AB-207

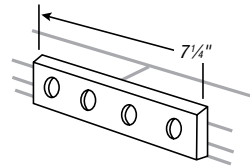

X-207

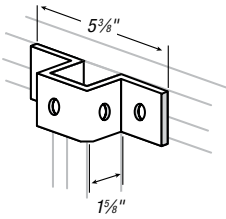

A210

For attaching A Series channel

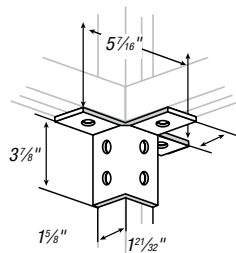

A218

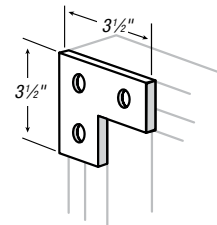

AB-219

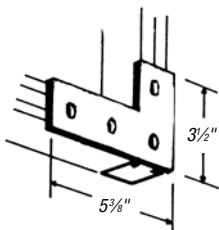

N-219

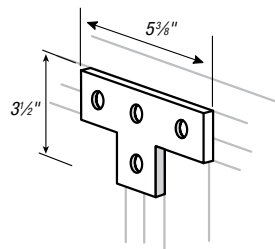

AB-220

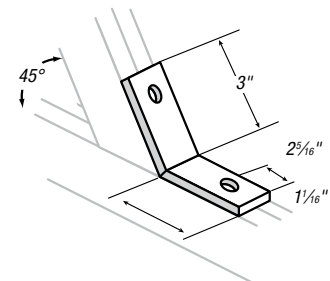

AB-227-WH

Special Metals and Finishes

White Painted Products (WH Suffix) (continued)



AB-241

| CAT. NO. | ROD SIZE (IN.) | STD. CTN. |
|------------|----------------|-----------|
| AB-241-1/4 | 1/4 | 100 |
| AB-241-3/8 | 3/8 | 100 |
| AB-241-1/2 | 1/2 | 100 |

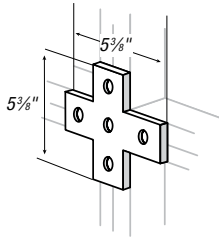

AB253

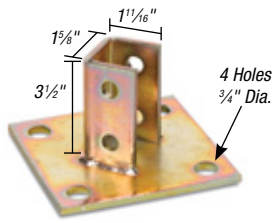

AP-232

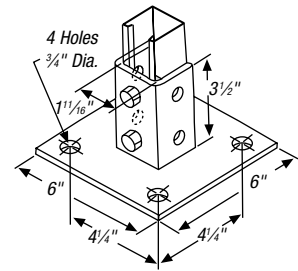

AP-232SQ

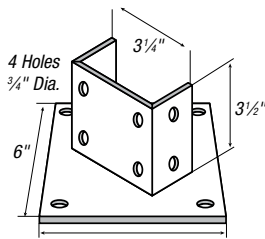

AP-235

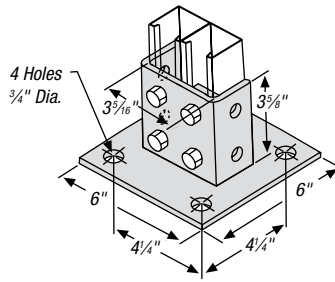

AP-235SQ

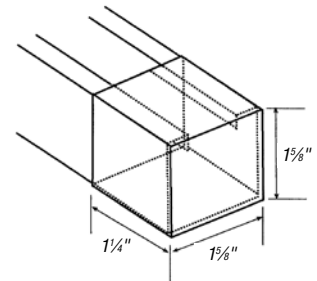

A804 NEOP WH
1 5/8" x 1 5/8"
White Plastisol End-Cap

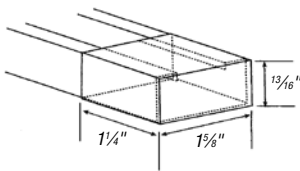

B 804 NEOP WH
1 5/8" x 1 3/16"
White End-Cap

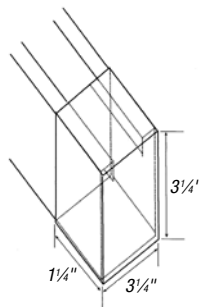

H804 NEOP WH
1 5/8" x 3/4"
White Plastisol End-Cap

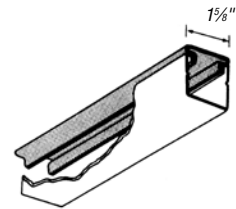

SPAB-844-PC — WHITE
White Closure Strip
For all channels

Technical Information

Design Data — Metal Framing Channel

Elements of Sections

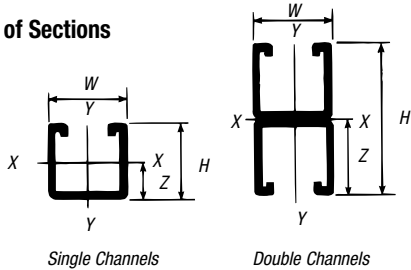

Nominal Thickness (IN.)

12 ga. = .105
 14 ga. = .075
 16 ga. = .060

I — Moment of Inertia
 S — Section of Modulus
 r — Radius of Gyration
 Z — Nominal Axis
 A — Area

Table 1 — Properties for Design: Single Channel

| CAT. NO. | H IN. | W IN. | A IN.2 | I IN.4 | S IN.3 | R IN. | X-X AXIS | | | Y-Y AXIS R IN. |
|----------|----------|----------|-----------|-----------|-----------|----------|----------|-----------|-----------|----------------------|
| | | | | | | | Z IN. | I IN.4 | S IN.3 | |
| A-1200 | 1.625 | 1.625 | .557 | .192 | .212 | .587 | .719 | .237 | .292 | .652 |
| B-1200 | .813 | 1.625 | .381 | .031 | .063 | .283 | .331 | .137 | .168 | .600 |
| C-1200 | 1.375 | 1.625 | .500 | .121 | .155 | .492 | .595 | .205 | .252 | .640 |
| E-1200 | 2.438 | 1.625 | .726 | .529 | .399 | .853 | 1.112 | .335 | .413 | .679 |
| H-1200 | 3.250 | 1.625 | .897 | 1.100 | .635 | 1.107 | 1.507 | .436 | .536 | .697 |
| A-1400 | 1.625 | 1.625 | .401 | .134 | .146 | .577 | .707 | .184 | .226 | .677 |
| B-1400 | .813 | 1.625 | .280 | .024 | .051 | .295 | .338 | .103 | .127 | .607 |

Table 1 — Properties for Design: Double Channel

| CAT. NO. | H IN. | W IN. | A IN.2 | I IN.4 | S IN.3 | R IN. | X-X AXIS | | | Y-Y AXIS R IN. |
|----------|----------|----------|-----------|-----------|-----------|----------|----------|-----------|-----------|----------------------|
| | | | | | | | Z IN. | I IN.4 | S IN.3 | |
| A-1202 | 3.250 | 1.625 | 1.114 | .948 | .583 | .992 | 1.625 | .474 | .584 | .652 |
| B-1202 | 1.626 | 1.625 | .762 | .147 | .181 | .439 | .813 | .274 | .337 | .600 |
| C-1202 | 2.750 | 1.625 | 1.000 | .595 | .433 | .772 | 1.375 | .409 | .504 | .640 |
| E-1202 | 4.876 | 1.625 | 1.450 | 2.854 | 1.171 | 1.402 | 2.438 | .672 | .827 | .680 |
| H-1202 | 6.500 | 1.625 | 1.794 | 6.273 | 1.930 | 1.870 | 3.250 | .871 | 1.072 | .697 |
| A-1402 | 3.250 | 1.625 | .801 | .668 | .411 | .913 | 1.625 | .367 | .452 | .677 |
| B-1402 | 1.626 | 1.625 | .560 | .112 | .138 | .447 | .813 | .206 | .254 | .607 |

Table 2 — Load Ratings for 1/2" Strut Nuts used in Superstrut® Channel

| CHANNEL NO. | SLIP RESISTANCE (LBS.) | PULL-OUT STRENGTH (LBS.) |
|-------------|------------------------|--------------------------|
| A-1200 | 1,500 | 2,000 |
| C-1200 | 1,500 | 2,000 |
| B-1200 | 1,400 | 1,400 |
| A-1400 | 1,000 | 1,400 |
| B-1400 | 1,000 | 1,400 |

Safety Factor of 3

If connections will be subjected to dynamic or seismic loading conditions, contact Thomas & Betts Technical Services for design assistance.

Technical Information

Design Data — Metal Framing Channel (continued)

Design Loads for Channel Used as Beam or Column.

Table 3

Beam Loads

Table 3 contains simple beam, uniformly-distributed loads calculated at 25,000 psi fiber stress. Beam loads are based on channel being loaded across the x-x axis. Loads are also listed at reduced deflections for long spans.

Maximum Loads @ 25,000 psi Stress

Maximum allowable deflections and maximum uniform loads for all spans @ 25,000 psi fiber stress.

Reduced Load for all 1/180 Span Deflection

For moderate deflections on the longer spans, reduced loads are listed which will produce a deflection equal to 1/180 of the span. When maximum loads do not induce deflections exceeding 1/180 x the span length, reduced loads are not required.

Reduced Load for 1/360 Span Deflection

For very slight deflections on the longer spans, reduced loads are listed which will produce a deflection equal to 1/360 of the span. When maximum loads do not induce deflections exceeding 1/360 x the span length, reduced loads are not required.

Concentrated Loads

To obtain values for concentrated loads from Table 3, multiply uniform load by .5 and deflection by 1.25.

Slotted, Punched or KO Channel

Reduce load rating 5%.

Long Span Deep Beams

Support in a manner to prevent rotation at supports and tie between supports to prevent twist.

Column Loads

Allowable column loads given are for uniform axial loading with pinned ends. For eccentric loading or other end conditions, reduce allowable loads according to standard engineering practice.

Dynamic Loads

Allowable dynamic loads may be calculated by dividing the static loads shown in Table 3, by 2.08.



Technical Information

Table 3 — Single Channel

| CAT. NO. | DEPTH (IN.) | GA. | MAXIMUM UNIFORM | | 1/180 SPAN | | 1/360 SPAN | | COL. LOAD |
|---------------------------|-------------|-----|-----------------|-------|------------|-------|------------|-------|-----------|
| | | | LOAD | DEFL. | LOAD | DEFL. | LOAD | DEFL. | |
| 12" Beam or Column | | | | | | | | | |
| A-1200 | 1½ | 12 | 3,534 | .014 | — | .067 | — | .033 | 10,533 |
| B-1200 | 1¾ | 12 | 1,050 | .026 | — | .067 | — | .033 | 6,683 |
| C-1200 | 1¾ | 12 | 2,584 | .016 | — | .067 | — | .033 | 9,345 |
| E-1200 | 2¼ | 12 | 6,650 | .010 | — | .067 | — | .033 | 13,830 |
| H-1200 | ¾ | 12 | 10,583 | .008 | — | .067 | — | .033 | 17,106 |
| A-1400 | 1½ | 14 | 2,434 | .015 | — | .067 | — | .033 | 7,575 |
| B-1400 | 1¾ | 14 | 850 | .028 | — | .067 | — | .033 | 4,950 |
| 18" Beam or Column | | | | | | | | | |
| A-1200 | 1½ | 12 | 2,355 | .033 | — | .100 | — | .050 | 10,210 |
| B-1200 | 1¾ | 12 | 700 | .059 | — | .100 | — | .050 | 6,058 |
| C-1200 | 1¾ | 12 | 1,723 | .038 | — | .100 | — | .050 | 8,970 |
| E-1200 | 2¼ | 12 | 4,434 | .023 | — | .100 | — | .050 | 13,482 |
| H-1200 | ¾ | 12 | 7,055 | .016 | — | .100 | — | .050 | 16,693 |
| A-1400 | 1½ | 14 | 1,623 | .031 | — | .100 | — | .050 | 7,334 |
| B-1400 | 1¾ | 14 | 566 | .063 | — | .100 | 453 | .050 | 4,150 |
| 24" Beam or Column | | | | | | | | | |
| A-1200 | 1½ | 12 | 1,766 | .058 | — | .133 | — | .067 | 9,842 |
| B-1200 | 1¾ | 12 | 525 | .105 | — | .133 | 333 | .067 | 5,315 |
| C-1200 | 1¾ | 12 | 1,291 | .066 | — | .133 | — | .067 | 8,545 |
| E-1200 | 2¼ | 12 | 3,325 | .039 | — | .133 | — | .067 | 13,082 |
| H-1200 | ¾ | 12 | 5,291 | .030 | — | .133 | — | .067 | 16,277 |
| A-1400 | 1½ | 14 | 1,216 | .056 | — | .133 | — | .067 | 7,058 |
| B-1400 | 1¾ | 14 | 425 | .110 | — | .133 | 258 | .067 | 4,000 |
| 30" Beam or Column | | | | | | | | | |
| A-1200 | 1½ | 12 | 1,414 | .089 | — | .167 | — | .083 | 9,419 |
| B-1200 | 1¾ | 12 | 420 | .164 | — | .167 | 266 | .083 | 4,465 |
| C-1200 | 1¾ | 12 | 1,034 | .104 | — | .167 | 1,040 | .083 | 8,060 |
| E-1200 | 2¼ | 12 | 2,660 | .063 | — | .167 | — | .083 | 12,640 |
| H-1200 | ¾ | 12 | 4,234 | .046 | — | .167 | — | .083 | 15,698 |
| A-1400 | 1½ | 14 | 974 | .088 | — | .167 | — | .083 | 6,753 |
| B-1400 | 1¾ | 14 | 340 | .172 | — | .167 | 165 | .083 | 3,420 |

When no numbers are shown, use the maximum uniform load.

Deflections are given in inches; loads in lbs.

Technical Information

Design Data — Metal Framing Channel (continued)

Table 3 — Double Channel (Single Channels Welded Back-to-Back)

| CAT. NO. | DEPTH (IN.) | GA. | MAXIMUM UNIFORM | | 1/180 SPAN | | 1/360 SPAN | | COL. LOAD | |
|---------------------------|-------------|-----|-----------------|-------|------------|-------|------------|-------|-----------|--|
| | | | LOAD | DEFL. | LOAD | DEFL. | LOAD | DEFL. | | |
| 12" Beam or Column | | | | | | | | | | |
| A-1202 | 3/4 | 12 | — | .008 | — | .067 | — | .033 | 21,177 | |
| B-1202 | 1½ | 12 | 3,016 | .016 | — | .067 | — | .033 | 14,110 | |
| C-1202 | 2¾ | 12 | — | .010 | — | .067 | — | .033 | 18,990 | |
| E-1202 | 4¾ | 12 | — | .005 | — | .067 | — | .033 | 27,623 | |
| H-1202 | 6½ | 12 | — | .004 | — | .067 | — | .033 | 34,210 | |
| A-1402 | 3/4 | 14 | — | .008 | — | .067 | — | .033 | 15,250 | |
| B-1402 | 1½ | 14 | 2,300 | .016 | — | .067 | — | .033 | 10,390 | |
| 18" Beam or Column | | | | | | | | | | |
| A-1202 | 3/4 | 12 | — | .018 | — | .100 | — | .050 | 20,609 | |
| B-1202 | 1½ | 12 | 2,011 | .036 | — | .100 | — | .050 | 13,440 | |
| C-1202 | 2¾ | 12 | 4,811 | .021 | — | .100 | — | .050 | 18,470 | |
| E-1202 | 4¾ | 12 | — | .013 | — | .100 | — | .050 | 16,926 | |
| H-1202 | 6½ | 12 | — | .009 | — | .100 | — | .050 | 33,390 | |
| A-1402 | 3/4 | 14 | — | .018 | — | .100 | — | .050 | 14,867 | |
| B-1402 | 1½ | 14 | 1,534 | .036 | — | .100 | — | .050 | 9,910 | |
| 24" Beam or Column | | | | | | | | | | |
| A-1202 | 3/4 | 12 | 4,858 | .031 | — | .133 | — | .067 | 19,974 | |
| B-1202 | 1½ | 12 | 1,509 | .064 | — | .133 | — | .067 | 12,670 | |
| C-1202 | 2¾ | 12 | 3,609 | .038 | — | .133 | — | .067 | 17,890 | |
| E-1202 | 4¾ | 12 | — | .021 | — | .133 | — | .067 | 26,143 | |
| H-1202 | 6½ | 12 | — | .016 | — | .133 | — | .067 | 32,435 | |
| A-1402 | 3/4 | 14 | 3,425 | .033 | — | .133 | — | .067 | 14,426 | |
| B-1402 | 1½ | 14 | 1,150 | .064 | — | .133 | — | .067 | 9,350 | |
| 30" Beam or Column | | | | | | | | | | |
| A-1202 | 3/4 | 12 | 3,886 | .049 | — | .167 | — | .083 | 19,261 | |
| B-1202 | 1½ | 12 | 1,206 | .100 | — | .167 | — | .083 | 11,803 | |
| C-1202 | 2¾ | 12 | 2,886 | .059 | — | .167 | — | .083 | 17,230 | |
| E-1202 | 4¾ | 12 | 7,806 | .034 | — | .167 | — | .083 | 25,259 | |
| H-1202 | 6½ | 12 | — | .025 | — | .167 | — | .083 | 31,395 | |
| A-1402 | 3/4 | 14 | 2,740 | .050 | — | .167 | — | .083 | 13,937 | |
| B-1402 | 1½ | 14 | 920 | .100 | — | .167 | — | .083 | 8,730 | |

When no numbers are shown, use the maximum uniform load.

Deflections are given in inches; loads in lbs.

Technical Information

Table 3 — Single Channel

| CAT. NO. | DEPTH (IN.) | GA. | MAXIMUM UNIFORM | | 1/180 SPAN | | 1/360 SPAN | | COL. LOAD |
|---------------------------|-------------|-----|-----------------|-------|------------|-------|------------|-------|-----------|
| | | | LOAD | DEFL. | LOAD | DEFL. | LOAD | DEFL. | |
| A-1200 | 1½ | 12 | 1,178 | .129 | — | .200 | 917 | .100 | 8,962 |
| B-1200 | 1¾ | 12 | 350 | .236 | — | .200 | 148 | .100 | 3,498 |
| C-1200 | 1⅝ | 12 | 861 | .149 | — | .200 | 578 | .100 | 7,525 |
| E-1200 | 2⅞ | 12 | 2,216 | .088 | — | .200 | — | .100 | 12,160 |
| H-1200 | 3¼ | 12 | 3,528 | .068 | — | .200 | — | .100 | 15,132 |
| A-1400 | 1⅝ | 14 | 811 | .126 | — | .200 | 640 | .100 | 6,416 |
| B-1400 | 1¾ | 14 | 284 | .248 | — | .200 | 115 | .100 | 2,755 |
| 42" Beam or Column | | | | | | | | | |
| A-1200 | 1½ | 12 | 1,010 | .175 | — | .233 | 674 | .117 | 8,466 |
| B-1200 | 1¾ | 12 | 300 | .323 | 217 | .233 | 109 | .117 | 2,579 |
| C-1200 | 1⅝ | 12 | 738 | .203 | — | .233 | 425 | .117 | 6,945 |
| E-1200 | 2⅞ | 12 | 1,900 | .120 | — | .233 | — | .117 | 11,698 |
| H-1200 | 3¼ | 12 | 3,024 | .091 | — | .233 | — | .117 | 14,514 |
| A-1400 | 1⅝ | 14 | 695 | .160 | — | .233 | 470 | .117 | 6,051 |
| B-1400 | 1¾ | 14 | 243 | .336 | 168 | .233 | 84 | .117 | 2,060 |
| 48" Beam or Column | | | | | | | | | |
| A-1200 | 1½ | 12 | 884 | .228 | — | .267 | 516 | .133 | 7,943 |
| B-1200 | 1¾ | 12 | 263 | .420 | 167 | .267 | 83 | .133 | 1,981 |
| C-1200 | 1⅝ | 12 | 646 | .265 | — | .267 | 325 | .133 | 6,325 |
| E-1200 | 2⅞ | 12 | 1,663 | .156 | — | .267 | — | .133 | 11,092 |
| H-1200 | 3¼ | 12 | 2,646 | .120 | — | .267 | — | .133 | 13,850 |
| A-1400 | 1⅝ | 14 | 609 | .120 | — | .267 | 360 | .133 | 5,658 |
| B-1400 | 1¾ | 14 | 213 | .440 | 129 | .267 | 64 | .133 | 1,580 |
| 54" Beam or Column | | | | | | | | | |
| A-1200 | 1½ | 12 | 785 | .289 | — | .300 | 408 | .150 | 7,369 |
| B-1200 | 1¾ | 12 | 234 | .533 | 132 | .300 | 66 | .150 | 1,555 |
| C-1200 | 1⅝ | 12 | 574 | .335 | — | .300 | 257 | .150 | 5,650 |
| E-1200 | 2⅞ | 12 | 1,478 | .198 | — | .300 | 1,123 | .150 | 10,505 |
| H-1200 | 3¼ | 12 | 2,351 | .151 | — | .300 | — | .150 | 13,150 |
| A-1400 | 1⅝ | 14 | 541 | .286 | — | .300 | 284 | .150 | 5,241 |
| B-1400 | 1¾ | 14 | 189 | .556 | 102 | .300 | 51 | .150 | 1,250 |

When no numbers are shown, use the maximum uniform load.

Deflections are given in inches; loads in lbs.

Technical Information

Design Data — Metal Framing Channel (continued)

Table 3 — Double Channel (Single Channels Welded Back-to-Back)

| CAT. NO. | DEPTH (IN.) | GA. | MAXIMUM UNIFORM | | 1/180 SPAN | | 1/360 SPAN | | COL. LOAD |
|---------------------------|-------------|-----|-----------------|-------|------------|-------|------------|-------|-----------|
| | | | LOAD | DEFL. | LOAD | DEFL. | LOAD | DEFL. | |
| 36" Beam or Column | | | | | | | | | |
| A-1202 | 3/4 | 12 | 3,239 | .071 | — | .200 | — | .100 | 18,470 |
| B-1202 | 1% | 12 | 1,005 | .144 | — | .200 | 702 | .100 | 10,840 |
| C-1202 | 2% | 12 | 2,400 | .085 | — | .200 | — | .100 | 16,500 |
| E-1202 | 4% | 12 | 6,505 | .048 | — | .200 | — | .100 | 24,316 |
| H-1202 | 6 1/2 | 12 | — | .036 | — | .200 | — | .100 | 30,265 |
| A-1402 | 3/4 | 14 | 2,284 | .071 | — | .200 | — | .100 | 13,416 |
| B-1402 | 1% | 14 | 766 | .144 | — | .200 | 535 | .100 | 8,050 |
| 42" Beam or Column | | | | | | | | | |
| A-1202 | 3/4 | 12 | 2,776 | .098 | — | .233 | — | .117 | 17,635 |
| B-1202 | 1% | 12 | 863 | .195 | — | .233 | 516 | .117 | 9,790 |
| C-1202 | 2% | 12 | 2,063 | .115 | — | .233 | — | .117 | 15,730 |
| E-1202 | 4% | 12 | 5,576 | .065 | — | .233 | — | .117 | 23,272 |
| H-1202 | 6 1/2 | 12 | 9,190 | .049 | — | .233 | — | .117 | 29,025 |
| A-1402 | 3/4 | 14 | 1,958 | .225 | — | .233 | — | .117 | 12,832 |
| B-1402 | 1% | 14 | 658 | .195 | — | .233 | 393 | .117 | 7,300 |
| 48" Beam or Column | | | | | | | | | |
| A-1202 | 3/4 | 12 | 2,429 | .128 | — | .267 | — | .133 | 16,730 |
| B-1202 | 1% | 12 | 754 | .255 | — | .267 | 395 | .133 | 8,640 |
| C-1202 | 2% | 12 | 1,804 | .151 | — | .267 | — | .133 | 14,890 |
| E-1202 | 4% | 12 | 4,879 | .085 | — | .267 | — | .133 | 22,170 |
| H-1202 | 6 1/2 | 12 | 8,041 | .064 | — | .267 | — | .133 | 27,700 |
| A-1402 | 3/4 | 14 | 1,713 | .128 | — | .267 | — | .133 | 12,223 |
| B-1402 | 1% | 14 | 575 | .255 | — | .267 | 301 | .133 | 6,480 |
| 54" Beam or Column | | | | | | | | | |
| A-1202 | 3/4 | 12 | 2,159 | .161 | — | .300 | — | .150 | 15,763 |
| B-1202 | 1% | 12 | 670 | .323 | — | .300 | 312 | .150 | 7,405 |
| C-1202 | 2% | 12 | 1,604 | .190 | — | .300 | 1,263 | .150 | 13,990 |
| E-1202 | 4% | 12 | 4,338 | .108 | — | .300 | — | .150 | 20,980 |
| H-1202 | 6 1/2 | 12 | 7,149 | .081 | — | .300 | — | .150 | 16,280 |
| A-1402 | 3/4 | 14 | 1,523 | .161 | — | .300 | — | .150 | 11,566 |
| B-1402 | 1% | 14 | 511 | .323 | — | .300 | 238 | .150 | 5,580 |

When no numbers are shown, use the maximum uniform load.

Deflections are given in inches; loads in lbs.

Technical Information

Table 3 — Single Channel

| CAT. NO. | DEPTH (IN.) | GA. | MAXIMUM UNIFORM | | 1/180 SPAN | | 1/360 SPAN | | COL. LOAD |
|---------------------------|-----------------|-----|-----------------|-------|------------|-------|------------|-------|-----------|
| | | | LOAD | DEFL. | LOAD | DEFL. | LOAD | DEFL. | |
| 60" Beam or Column | | | | | | | | | |
| A-1200 | 1 $\frac{5}{8}$ | 12 | 706 | .358 | — | .333 | 330 | .167 | 6,762 |
| B-1200 | 1 $\frac{3}{8}$ | 12 | 210 | .658 | 107 | .333 | 53 | .167 | — |
| C-1200 | 1 $\frac{1}{8}$ | 12 | 516 | .414 | — | .333 | 208 | .167 | 4,920 |
| E-1200 | 2 $\frac{1}{8}$ | 12 | 1,330 | .244 | — | .333 | 909 | .167 | 9,874 |
| H-1200 | 3 $\frac{1}{4}$ | 12 | 2,116 | .186 | — | .333 | — | .167 | 12,406 |
| A-1400 | 1 $\frac{5}{8}$ | 14 | 486 | .353 | — | .333 | 231 | .167 | 4,792 |
| B-1400 | 1 $\frac{3}{8}$ | 14 | 170 | .687 | 82 | .333 | 41 | .167 | — |
| 66" Beam or Column | | | | | | | | | |
| A-1200 | 1 $\frac{5}{8}$ | 12 | 643 | .432 | — | .367 | 273 | .183 | 6,127 |
| B-1200 | 1 $\frac{3}{8}$ | 12 | 191 | .795 | 88 | .367 | 44 | .183 | — |
| C-1200 | 1 $\frac{1}{8}$ | 12 | 470 | .501 | 344 | .367 | 172 | .183 | 4,145 |
| E-1200 | 2 $\frac{1}{8}$ | 12 | 1,210 | .295 | — | .367 | 753 | .183 | 9,211 |
| H-1200 | 3 $\frac{1}{4}$ | 12 | 1,924 | .226 | — | .367 | — | .183 | 11,616 |
| A-1400 | 1 $\frac{5}{8}$ | 14 | 443 | .426 | — | .367 | 190 | .183 | 4,311 |
| B-1400 | 1 $\frac{3}{8}$ | 14 | 155 | .831 | 68 | .367 | 35 | .183 | — |
| 72" Beam or Column | | | | | | | | | |
| A-1200 | 1 $\frac{5}{8}$ | 12 | 589 | .514 | 459 | .400 | 299 | .200 | 5,436 |
| B-1200 | 1 $\frac{3}{8}$ | 12 | 175 | .946 | 74 | .400 | 37 | .200 | — |
| C-1200 | 1 $\frac{1}{8}$ | 12 | 430 | .595 | 289 | .400 | 144 | .200 | 3,485 |
| E-1200 | 2 $\frac{1}{8}$ | 12 | 1,108 | .351 | — | .400 | 632 | .200 | 8,509 |
| H-1200 | 3 $\frac{1}{4}$ | 12 | 1,839 | .269 | — | .400 | 1,313 | .200 | 10,782 |
| A-1400 | 1 $\frac{5}{8}$ | 14 | 405 | .506 | 320 | .400 | 160 | .200 | 3,809 |
| B-1400 | 1 $\frac{3}{8}$ | 14 | 141 | .989 | 57 | .400 | 29 | .200 | — |
| 84" Beam or Column | | | | | | | | | |
| A-1200 | 1 $\frac{5}{8}$ | 12 | 505 | .700 | 337 | .467 | 168 | .233 | 4,061 |
| B-1200 | 1 $\frac{3}{8}$ | 12 | — | — | 54 | .467 | 27 | .233 | — |
| C-1200 | 1 $\frac{1}{8}$ | 12 | 369 | .811 | 212 | .467 | 106 | .233 | 2,565 |
| E-1200 | 2 $\frac{1}{8}$ | 12 | 950 | .479 | — | .467 | 464 | .233 | 6,991 |
| H-1200 | 3 $\frac{1}{4}$ | 12 | 1,513 | .366 | — | .467 | 965 | .233 | 8,988 |
| A-1400 | 1 $\frac{5}{8}$ | 14 | 348 | .691 | 235 | .467 | 118 | .233 | 2,827 |
| B-1400 | 1 $\frac{3}{8}$ | 14 | — | — | 42 | .467 | 21 | .233 | — |

When no numbers are shown, use the maximum uniform load.

Deflections are given in inches; loads in lbs.

Technical Information

Design Data — Metal Framing Channel (continued)

Table 3 — Double Channel (Single Channels Welded Back-to-Back)

| CAT. NO. | DEPTH (IN.) | GA. | MAXIMUM UNIFORM | | 1/180 SPAN | | 1/360 SPAN | | COL. LOAD |
|---------------------------|-------------|-----|-----------------|-------|------------|-------|------------|-------|-----------|
| | | | LOAD | DEFL. | LOAD | DEFL. | LOAD | DEFL. | |
| 60" Beam or Column | | | | | | | | | |
| A-1202 | 3/4 | 12 | 1,944 | .199 | — | .333 | — | .167 | 14,738 |
| B-1202 | 1 1/8 | 12 | 604 | .398 | — | .333 | 253 | .167 | 6,100 |
| C-1202 | 2 1/4 | 12 | 1,444 | .235 | — | .333 | 1,023 | .167 | 13,050 |
| E-1202 | 4 1/8 | 12 | 3,904 | .133 | — | .333 | — | .167 | 19,734 |
| H-1202 | 6 1/2 | 12 | 6,434 | .100 | — | .333 | — | .167 | 24,810 |
| A-1402 | 3/4 | 14 | 1,370 | .199 | — | .333 | — | .167 | 10,878 |
| B-1402 | 1 1/8 | 14 | 460 | .399 | — | .333 | 193 | .167 | 4,640 |
| 66" Beam or Column | | | | | | | | | |
| A-1202 | 3/4 | 12 | 1,766 | .240 | — | .367 | 1,347 | .183 | 13,646 |
| B-1202 | 1 1/8 | 12 | 549 | .481 | 418 | .367 | 209 | .183 | 5,055 |
| C-1202 | 2 1/4 | 12 | 1,313 | .285 | — | .367 | 846 | .183 | 12,030 |
| E-1202 | 4 1/8 | 12 | 3,549 | .180 | — | .367 | — | .183 | 18,415 |
| H-1202 | 6 1/2 | 12 | 5,849 | .120 | — | .367 | — | .183 | 23,230 |
| A-1402 | 3/4 | 14 | 1,245 | .241 | — | .367 | 949 | .183 | 10,133 |
| B-1402 | 1 1/8 | 14 | 419 | .483 | 318 | .367 | 159 | .183 | 3,840 |
| 72" Beam or Column | | | | | | | | | |
| A-1202 | 3/4 | 12 | 1,620 | .286 | — | .400 | 1,132 | .200 | 12,500 |
| B-1202 | 1 1/8 | 12 | 503 | .574 | 351 | .400 | 176 | .200 | 4,230 |
| C-1202 | 2 1/4 | 12 | 1,203 | .339 | — | .400 | 710 | .200 | 10,980 |
| E-1202 | 4 1/8 | 12 | 3,253 | .191 | — | .400 | — | .200 | 17,023 |
| H-1202 | 6 1/2 | 12 | 5,361 | .143 | — | .400 | — | .200 | 21,560 |
| A-1402 | 3/4 | 14 | 1,141 | .286 | — | .400 | 798 | .200 | 9,340 |
| B-1402 | 1 1/8 | 14 | 384 | .574 | 267 | .400 | 134 | .200 | 3,220 |
| 84" Beam or Column | | | | | | | | | |
| A-1202 | 3/4 | 12 | 1,388 | .390 | — | .467 | 832 | .233 | 9,992 |
| B-1202 | 1 1/8 | 12 | 431 | .780 | 258 | .467 | 129 | .233 | 3,100 |
| C-1202 | 2 1/4 | 12 | 1,031 | .461 | — | .467 | 522 | .233 | 8,670 |
| E-1202 | 4 1/8 | 12 | 2,788 | .260 | — | .467 | — | .233 | 13,993 |
| H-1202 | 6 1/2 | 12 | 4,595 | .195 | — | .467 | — | .233 | 17,975 |
| A-1402 | 3/4 | 14 | 979 | .390 | — | .467 | 586 | .233 | 7,682 |
| B-1402 | 1 1/8 | 14 | 329 | .781 | 197 | .467 | 98 | .233 | 2,370 |

When no numbers are shown, use the maximum uniform load.

Deflections are given in inches; loads in lbs.

Technical Information

Table 3 — Single Channel

| CAT. NO. | DEPTH (IN.) | GA. | MAXIMUM UNIFORM | | 1/180 SPAN | | 1/360 SPAN | | COL. LOAD |
|----------------------------|-------------|-----|-----------------|-------|------------|-------|------------|-------|-----------|
| | | | LOAD | DEFL. | LOAD | DEFL. | LOAD | DEFL. | |
| 96" Beam or Column | | | | | | | | | |
| A-1200 | 1½ | 12 | 441 | .914 | 258 | .533 | 129 | .267 | 3,108 |
| B-1200 | 1¾ | 12 | — | — | 42 | .533 | 21 | .267 | — |
| C-1200 | 1⅝ | 12 | 323 | 1.059 | 163 | .533 | 81 | .267 | 1,960 |
| E-1200 | 2¼ | 12 | 831 | .730 | — | .533 | 355 | .267 | 5,423 |
| H-1200 | 3¼ | 12 | 1,323 | .478 | — | .533 | 739 | .267 | 7,059 |
| A-1400 | 1½ | 14 | 304 | .903 | 180 | .533 | 90 | .267 | 2,615 |
| B-1400 | 1¾ | 14 | — | — | 32 | .533 | 16 | .267 | — |
| 108" Beam or Column | | | | | | | | | |
| A-1200 | 1½ | 12 | 393 | 1.156 | 204 | .600 | 102 | .300 | 2,456 |
| B-1200 | 1¾ | 12 | — | — | 33 | .600 | 16 | .300 | — |
| C-1200 | 1⅝ | 12 | 288 | 1.350 | 128 | .600 | 64 | .300 | — |
| E-1200 | 2¼ | 12 | 739 | .790 | 561 | .600 | 281 | .300 | 4,291 |
| H-1200 | 3¼ | 12 | 1,176 | .605 | — | .600 | 584 | .300 | 5,579 |
| A-1400 | 1½ | 14 | 270 | 1.141 | 142 | .600 | 71 | .300 | 1,708 |
| B-1400 | 1¾ | 14 | — | — | 25 | .600 | 13 | .300 | — |
| 120" Beam or Column | | | | | | | | | |
| A-1200 | 1½ | 12 | 354 | 1.425 | 165 | .667 | 83 | .333 | — |
| B-1200 | 1¾ | 12 | — | — | 27 | .667 | 13 | .333 | — |
| C-1200 | 1⅝ | 12 | 259 | 1.663 | 104 | .667 | 52 | .333 | — |
| E-1200 | 2¼ | 12 | 665 | .976 | 455 | .667 | 227 | .333 | 3,478 |
| H-1200 | 3¼ | 12 | 1,059 | .746 | — | .667 | 473 | .333 | 4,521 |
| A-1400 | 1½ | 14 | 244 | 1.413 | 114 | .667 | 57 | .333 | — |
| B-1400 | 1¾ | 14 | — | — | 21 | .667 | 10 | .333 | — |
| 144" Beam or Column | | | | | | | | | |
| A-1200 | 1½ | 12 | — | — | 115 | .800 | 57 | .400 | — |
| C-1200 | 1⅝ | 12 | — | — | 72 | .800 | 36 | .400 | — |
| E-1200 | 2¼ | 12 | 554 | 1.400 | 315 | .800 | 158 | .400 | — |
| H-1200 | 3¼ | 12 | 883 | 1.075 | 657 | .800 | 328 | .400 | — |
| A-1400 | 1½ | 14 | — | — | 80 | .800 | 40 | .400 | — |

When no numbers are shown, use the maximum uniform load.

Deflections are given in inches; loads in lbs.

Technical Information

Design Data — Metal Framing Channel (*continued*)

Table 3 — Double Channel (Single Channels Welded Back-to-Back)

| CAT. NO. | DEPTH (IN.) | GA. | MAXIMUM UNIFORM | | 1/180 SPAN | | 1/360 SPAN | | COL. LOAD | |
|----------------------------|-------------|-----|-----------------|-------|------------|-------|------------|-------|-----------|--|
| | | | LOAD | DEFL. | LOAD | DEFL. | LOAD | DEFL. | | |
| 96" Beam or Column | | | | | | | | | | |
| A-1202 | 3/4 | 12 | 1,215 | .509 | — | .533 | 637 | .267 | 7,675 | |
| B-1202 | 1 1/8 | 12 | 378 | 1.019 | 197 | .533 | 99 | .267 | — | |
| C-1202 | 2 1/4 | 12 | 903 | .603 | — | .533 | 400 | .267 | 6,640 | |
| E-1202 | 4 1/8 | 12 | 2,440 | .340 | — | .533 | 1,917 | .267 | 10,875 | |
| H-1202 | 6 1/2 | 12 | 4,021 | .255 | — | .533 | — | .267 | 14,120 | |
| A-1402 | 3/4 | 14 | 856 | .509 | — | .533 | 449 | .267 | 5,951 | |
| B-1402 | 1 1/8 | 14 | 288 | 1.020 | 150 | .533 | 75 | .267 | — | |
| 108" Beam or Column | | | | | | | | | | |
| A-1202 | 3/4 | 12 | 1,080 | .644 | — | .600 | 503 | .300 | 6,071 | |
| B-1202 | 1 1/8 | 12 | 355 | 1.290 | 156 | .600 | 78 | .300 | — | |
| C-1202 | 2 1/4 | 12 | 801 | .763 | 632 | .600 | 316 | .300 | 5,250 | |
| E-1202 | 4 1/8 | 12 | 2,169 | .430 | — | .600 | 1,515 | .300 | 8,599 | |
| H-1202 | 6 1/2 | 12 | 3,574 | .323 | — | .600 | — | .300 | 11,160 | |
| A-1402 | 3/4 | 14 | 761 | .644 | — | .600 | 355 | .300 | 4,702 | |
| B-1402 | 1 1/8 | 14 | 255 | 1.290 | 119 | .600 | 59 | .300 | — | |
| 120" Beam or Column | | | | | | | | | | |
| A-1202 | 3/4 | 12 | 971 | .795 | — | .667 | 408 | .333 | — | |
| B-1202 | 1 1/8 | 12 | 301 | 1.588 | 126 | .667 | 63 | .333 | — | |
| C-1202 | 2 1/4 | 12 | 721 | .941 | 512 | .667 | 256 | .333 | 4,250 | |
| E-1202 | 4 1/8 | 12 | 1,951 | .531 | — | .667 | 1,227 | .333 | 6,946 | |
| H-1202 | 6 1/2 | 12 | 3,216 | .398 | — | .667 | — | .333 | 9,040 | |
| A-1402 | 3/4 | 14 | 685 | .796 | — | .667 | 287 | .333 | 3,805 | |
| B-1402 | 1 1/8 | 14 | 230 | 1.600 | 96 | .667 | 48 | .333 | — | |
| 144" Beam or Column | | | | | | | | | | |
| A-1202 | 3/4 | 12 | 810 | 1.145 | 566 | .800 | 283 | .400 | — | |
| B-1202 | 1 1/8 | 12 | — | — | 88 | .800 | 44 | .400 | — | |
| C-1202 | 2 1/4 | 12 | 601 | 1.350 | 355 | .800 | 178 | .400 | — | |
| E-1202 | 4 1/8 | 12 | 1,626 | .764 | — | .800 | 852 | .400 | — | |
| H-1202 | 6 1/2 | 12 | 2,680 | .573 | — | .800 | 1,873 | .400 | — | |
| A-1402 | 3/4 | 14 | 571 | 1.146 | 399 | .800 | 199 | .400 | — | |
| B-1402 | 1 1/8 | 14 | — | — | 67 | .800 | 33 | .400 | — | |

When no numbers are shown, use the maximum uniform load.

Deflections are given in inches; loads in lbs.

Technical Information

Table 3 — Single Channel

| CAT. NO. | DEPTH (IN.) | GA. | MAXIMUM UNIFORM | | 1/180 SPAN | | 1/360 SPAN | | COL. LOAD |
|----------------------------|-------------|-----|-----------------|-------|------------|-------|------------|-------|-----------|
| | | | LOAD | DEFL. | LOAD | DEFL. | LOAD | DEFL. | |
| 168" Beam or Column | | | | | | | | | |
| A-1200 | 1½ | 12 | — | — | 84 | .933 | 42 | .467 | — |
| C-1200 | 1½ | 12 | — | — | 53 | .933 | 27 | .467 | — |
| E-1200 | 2¼ | 12 | 475 | 1.912 | 233 | .933 | 116 | .467 | — |
| H-1200 | 3¼ | 12 | 756 | 1.463 | 482 | .933 | 241 | .467 | — |
| A-1400 | 1½ | 14 | — | — | 60 | .933 | 30 | .467 | — |
| 192" Beam or Column | | | | | | | | | |
| E-1200 | 2¼ | 12 | — | — | 178 | 1.07 | 89 | .533 | — |
| H-1200 | 3¼ | 12 | 661 | 1.910 | 369 | 1.07 | 185 | .533 | — |
| 216" Beam or Column | | | | | | | | | |
| E-1200 | 2¼ | 12 | — | — | 140 | 1.20 | 70 | .600 | — |
| H-1200 | 3¼ | 12 | — | — | 292 | 1.20 | 146 | .600 | — |
| 240" Beam or Column | | | | | | | | | |
| E-1200 | 2¼ | 12 | — | — | 114 | .334 | 57 | .667 | — |
| H-1200 | 3¼ | 12 | — | — | 236 | .334 | 118 | .667 | — |

When no numbers are shown, use the maximum uniform load.

Deflections are given in inches; loads in lbs.

Technical Information

Design Data — Metal Framing Channel (continued)

Table 3 — Double Channel (Single Channels Welded Back-to-Back)

| CAT. NO. | DEPTH (IN.) | GA. | MAXIMUM UNIFORM | | 1/180 SPAN | | 1/360 SPAN | | COL. LOAD |
|----------------------------|-------------|-----|-----------------|-------|------------|-------|------------|-------|-----------|
| | | | LOAD | DEFL. | LOAD | DEFL. | LOAD | DEFL. | |
| 168" Beam or Column | | | | | | | | | |
| A-1202 | 3/4 | 12 | 694 | 1.563 | 916 | .933 | 208 | .467 | — |
| B-1202 | 1 1/8 | 12 | — | — | 64 | .933 | 32 | .467 | — |
| C-1202 | 2 1/4 | 12 | 515 | 1.850 | 261 | .933 | 130 | .467 | — |
| E-1202 | 4 1/8 | 12 | 1,394 | 1.040 | 1,255 | .933 | 626 | .467 | — |
| H-1202 | 6 1/2 | 12 | 2,298 | .780 | — | .933 | 1,326 | .467 | — |
| A-1402 | 3/4 | 14 | 489 | 1.563 | 293 | .933 | 147 | .467 | — |
| B-1402 | 1 1/8 | 14 | — | — | 49 | .933 | 25 | .467 | — |
| 192" Beam or Column | | | | | | | | | |
| A-1202 | 3/4 | 12 | — | — | 318 | 1.07 | 159 | .533 | — |
| — | — | — | — | — | — | — | — | — | — |
| C-1202 | 2 1/4 | 12 | — | — | 200 | 1.07 | 100 | .533 | — |
| E-1202 | 4 1/8 | 12 | 1,220 | 1.363 | 958 | 1.07 | 479 | .533 | — |
| H-1202 | 6 1/2 | 12 | 2,010 | 1.019 | — | 1.07 | 1,053 | .533 | — |
| A-1402 | 3/4 | 14 | — | — | 224 | 1.07 | 112 | .533 | — |
| — | — | — | — | — | — | — | — | — | — |
| 216" Beam or Column | | | | | | | | | |
| A-1202 | 3/4 | 12 | — | — | 252 | 1.20 | 126 | .600 | — |
| — | — | — | — | — | — | — | — | — | — |
| C-1202 | 2 1/4 | 12 | — | — | 158 | 1.20 | 79 | .600 | — |
| E-1202 | 4 1/8 | 12 | 1,084 | 1.725 | 757 | 1.20 | 379 | .600 | — |
| H-1202 | 6 1/2 | 12 | 1,788 | 1.288 | — | 1.20 | 832 | .600 | — |
| A-1402 | 3/4 | 14 | — | — | 177 | 1.20 | 89 | .600 | — |
| — | — | — | — | — | — | — | — | — | — |
| 240" Beam or Column | | | | | | | | | |
| A-1202 | 3/4 | 12 | — | — | 204 | 1.33 | 102 | .667 | — |
| — | — | — | — | — | — | — | — | — | — |
| C-1202 | 2 1/4 | 12 | — | — | 128 | 1.33 | 64 | .667 | — |
| E-1202 | 4 1/8 | 12 | — | — | 613 | 1.33 | 307 | .667 | — |
| H-1202 | 6 1/2 | 12 | 1,609 | 1.588 | — | 1.33 | 674 | .667 | — |
| A-1402 | 3/4 | 14 | — | — | 144 | 1.33 | 72 | .667 | — |
| — | — | — | — | — | — | — | — | — | — |

When no numbers are shown, use the maximum uniform load.

Deflections are given in inches; loads in lbs.

Technical Information

Table 4 — Safe Bearing Loads for 1½" Channel and Combinations

| SECTION | RECOMMENDED LOAD IN LBS. | SECTION | RECOMMENDED LOAD IN LBS. | SECTION | RECOMMENDED LOAD IN LBS. |
|---------|--------------------------|---------|--------------------------|---------|--------------------------|
| A-1200 | 5,000 | A-1200 | 3,500 | A-1200 | 8,000 |
| A-1400 | 3,500 | A-1400 | 2,500 | A-1400 | 5,500 |
| B-1200 | 6,000 | B-1200 | 4,000 | B-1200 | 9,000 |
| B-1400 | 3,400 | B-1400 | 2,600 | B-1400 | 4,800 |
| C-1200 | 5,000 | C-1200 | 3,500 | C-1200 | 8,000 |
| E-1200 | 5,000 | E-1200 | 3,500 | E-1200 | 8,000 |
| H-1200 | 4,000 | H-1200 | 2,000 | H-1200 | 5,500 |

Safety factor of 2½

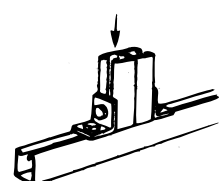
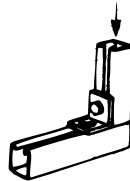
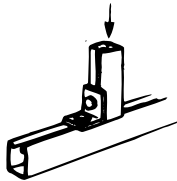
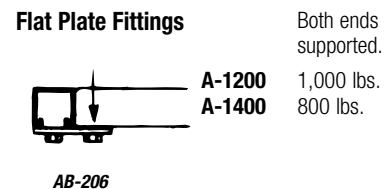
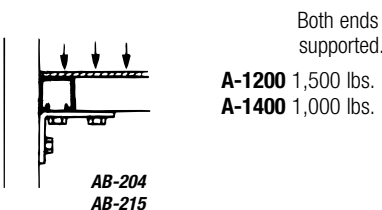
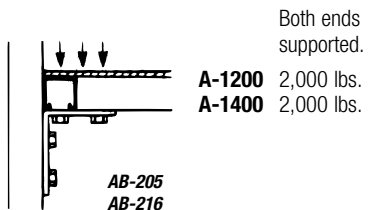
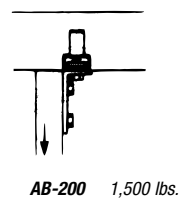
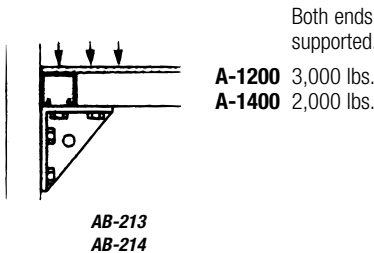
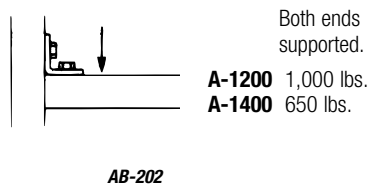
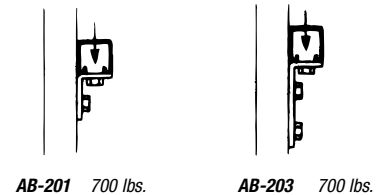
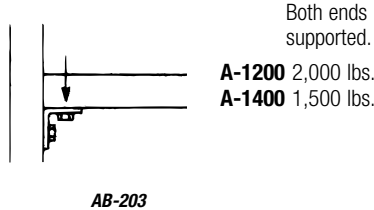
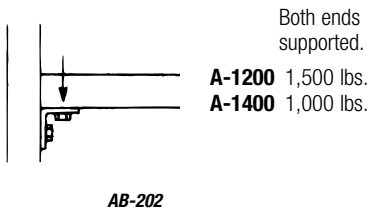

Table 5 — Design Load Table for Typical Channel Connections

Safety factor of 2½ based on ultimate strength of the connection. Load diagrams indicate up to three design loads, for 12 gauge, 14 gauge and 16 gauge channel applications.

90° Fittings (when used in position shown).



Technical Information

Design Applications

Cantilever Beams

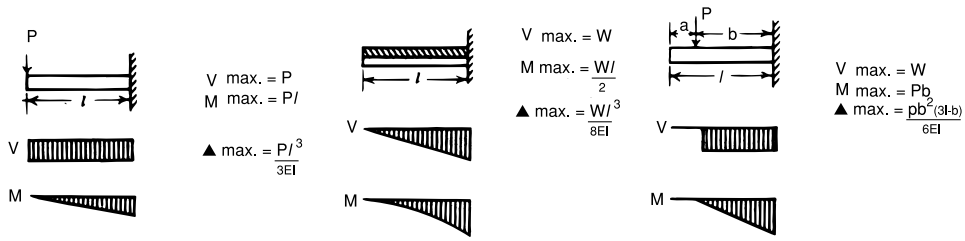

Simple Beams

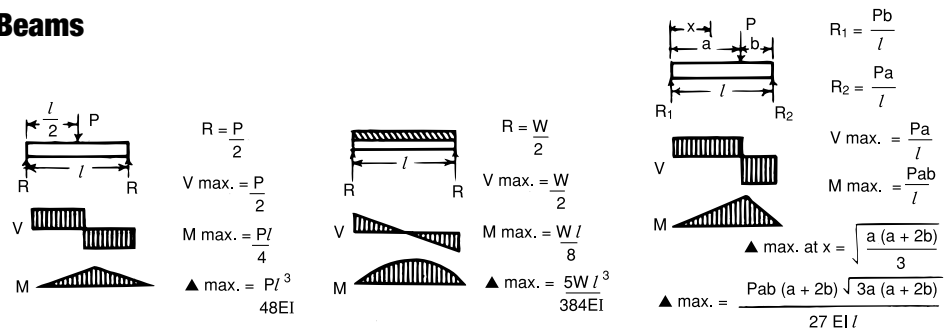

Beams Fixed on One End, Supported at Other

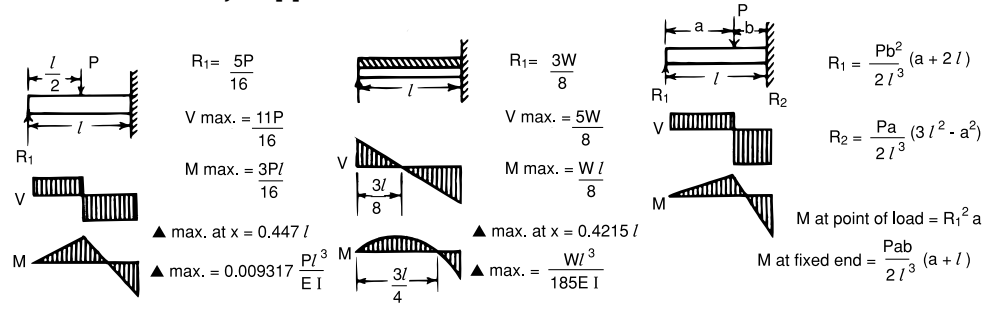

Beams Fixed at Both Ends

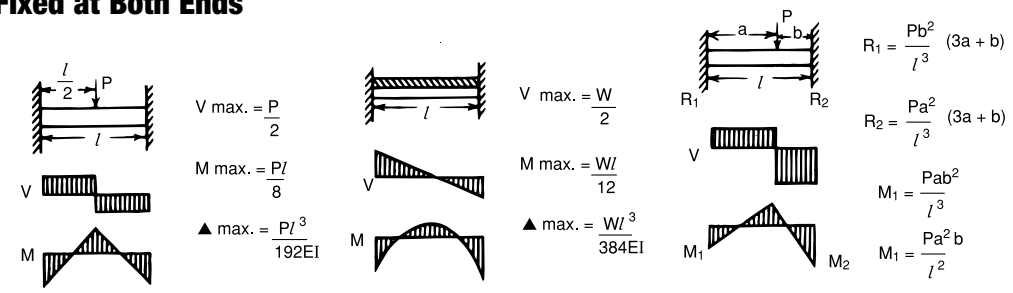







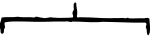
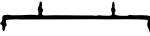

R – Reaction
 M – Moment
 P – Concentrated load
 W – Total uniform load
 V – Shear
 Δ – Deflection
 E – Modulus of Elasticity
 I – Moment of Inertia

Technical Information

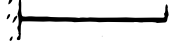
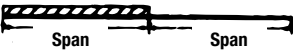
Load tables on **pages B-200–B-210** for A, B, C, E and H series channel are for single span beams supported at the ends. These can be used in the majority of cases. There are times when it is necessary to know what happens with other loading and support conditions. Some common arrangements are shown in Table 6. Simply multiply the loads from the Design Load Tables times the factors given in Table 6. Examples shown on **page B-214**.

Table 6 — Conversion Factors for Beams with Various Static Loading Conditions

| LOAD AND SUPPORT CONDITION | | | LOAD FACTOR | DEFLECTION FACTOR |
|----------------------------|---|--|-------------|-------------------|
| 1. | Simple Beam — Uniform Load |  | 1.00 | 1.00 |
| 2. | Simple Beam — Concentrated Load at Center |  | .50 | 1.25 |
| 3. | Simple Beam — Two Equal Concentrated Loads at ¼ Points |  | 1.00 | 1.10 |
| 4. | Beam Fixed at Both Ends — Uniform Load |  | 1.50 | .30 |
| 5. | Beam Fixed at Both Ends — Concentrated Load at Center |  | 1.00 | .40 |
| 6. | Cantilever Beam — Uniform Load |  | .25 | 2.40 |
| 7. | Cantilever Beam — Concentrated Load at End |  | .12 | 3.20 |
| 8. | Continuous Beam — Two Equal Spans — Uniform Load on One Span |  | 1.30 | .92 |
| 9. | Continuous Beam — Two Equal Spans |  | 1.00 | .42 |
| 10. | Continuous Beam — Two Equal Spans — Concentrated Load at Center of One Span |  | .62 | .71 |
| 11. | Continuous Beam — Two Equal Spans — Concentrated Load at Center of Both Spans |  | .67 | .48 |

Technical Information

Design Applications (continued)

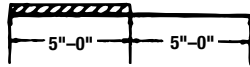

Example I

Problem:

Determine the load and deflection of an A-1200 beam continuous over one support and loaded uniformly on one span.

Solution:

- A. From load table 3 for A-1200 the load for a 5'0" span is 706 lbs. and deflection is .358".
- B. Multiply by factors from Table 6.
 $Load = 706 \text{ lbs.} \times 1.30 = 917.8 \text{ lbs.}$
 $Deflection = .358 \times .92 = .329"$

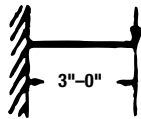

Example II

Problem:

Determine load and deflection of an E-1200 cantilever beam with a concentrated load on the end.

Solution:

- A. From load table 3 for E-1200 the load for a 3'0" span is 2216 lbs. and deflection is .088".
- B. Multiply by factors from Table 6.
 $Load = 2216 \text{ lbs.} \times .12 = 265.9 \text{ lbs.}$
 $Deflection = .088 \times 3.20 = .282"$

Illustration 1

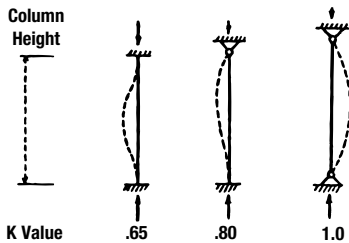

Column Loading

The load bearing capacity of column or compression members is a function of the inherent configurational strength, the unbraced length and design of the end connections.

Values of axial column loading given in Table 3 were calculated using a rotationally free and translation fixed correction at each end (see illustration I). This gives an end condition constant (K) of 1.

If other end conditions are used, axial loading should be calculated using procedures in the AISI specification for the design of cold formed steel structural members (SG671) and the engineering values for Superstrut channel given in Table 1.

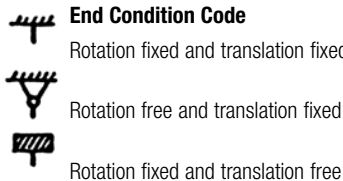

Technical Information

Table 7 — Load Carrying Capacities of Hot-Rolled Steel Rod

| DIMENSIONS (IN.) — LOADS | |
|--------------------------|------------------|
| NOMINAL ROD DIA. | ROOT AREA THREAD |
| 1/8 | .068 |
| 1/2 | .126 |
| 5/8 | .202 |
| 3/4 | .302 |
| 7/8 | .419 |

Safety factor of 5.

Table 8 — Rod Size Determined by Pipe Size for Fire Protection

| DIMENSIONS (IN.) — LOADS | |
|--------------------------|------------------|
| NOMINAL ROD DIA. | ROOT AREA THREAD |
| 3/4 to 2 | 1/8 |
| 2 1/2 to 3 1/2 | 1/2 |
| 4 to 5 | 5/8 |
| 6 | 3/4 |
| 8 to 12 | 7/8 |

Safety factor of 5.

Table 9 — Maximum Spacing between Pipe Supports

| Steel Pipe | | | | | | | | | | | | | | | | | | | |
|----------------------|-----|-----|---|-------|-------|-------|-------|-------|-------|----|----|----|----|----|----|----|----|----|----|
| Nom. Pipe Size (IN.) | 1/2 | 3/4 | 1 | 1 1/2 | 2 | 2 1/2 | 3 | 3 1/2 | 4 | 5 | 6 | 8 | 10 | 12 | 14 | 16 | 18 | 20 | 24 |
| Max. Spacing (FT.) | 5 | 6 | 7 | 9 | 10 | 11 | 12 | 13 | 14 | 16 | 17 | 19 | 22 | 23 | 25 | 27 | 28 | 30 | 32 |
| Copper Size | | | | | | | | | | | | | | | | | | | |
| Nom. Pipe Size (IN.) | 1/2 | 3/4 | 1 | 1 1/4 | 1 1/2 | 2 | 2 1/2 | 3 | 3 1/2 | 4 | | | | | | | | | |
| Max. Spacing (FT.) | 5 | 6 | 6 | 7 | 8 | 9 | 10 | 10 | 11 | 12 | | | | | | | | | |

Table 10 — Minimum Spacing (IN.) between Centers of Standard Pipe When Using Superstrut #702 Pipe Straps

| NOM. PIPE SIZE | 1/2 | 3/4 | 1 | 1 1/4 | 1 1/2 | 2 | 2 1/2 | 3 | 3 1/2 | 4 | 5 | 6 | 8 |
|----------------|---------|---------|---------|--------|--------|--------|---------|--------|--------|--------|--------|-------|--------|
| 1/2 | 1 1/16 | — | — | — | — | — | — | — | — | — | — | — | — |
| 3/4 | 1 1/16 | 1 1/16 | — | — | — | — | — | — | — | — | — | — | — |
| 1 | 1 1/2 | 1 5/8 | 1 3/4 | — | — | — | — | — | — | — | — | — | — |
| 1 1/4 | 1 3/4 | 1 7/8 | 2 | 2 1/4 | — | — | — | — | — | — | — | — | — |
| 1 1/2 | 1 15/16 | 2 1/16 | 2 3/16 | 2 7/16 | 2 9/16 | — | — | — | — | — | — | — | — |
| 2 | 2 3/16 | 2 5/16 | 2 1/2 | 2 3/4 | 2 7/8 | 3 1/8 | — | — | — | — | — | — | — |
| 2 1/2 | 2 7/16 | 2 9/16 | 2 3/4 | 3 | 3 1/8 | 3 1/4 | 3 3/8 | — | — | — | — | — | — |
| 3 | 2 13/16 | 2 11/16 | 3 1/16 | 3 3/16 | 3 1/2 | 3 3/4 | 4 | 4 1/16 | — | — | — | — | — |
| 3 1/2 | 3 1/8 | 3 1/4 | 3 3/8 | 3 5/8 | 3 3/4 | 4 1/16 | 4 1/8 | 4 3/8 | 4 1/16 | — | — | — | — |
| 4 | 3 1/16 | 3 3/16 | 3 15/16 | 4 1/16 | 4 1/8 | 4 5/8 | 4 15/16 | 5 1/4 | 5 1/8 | — | — | — | — |
| 6 | 4 3/4 | 4 7/8 | 5 | 5 1/4 | 5 1/2 | 5 5/8 | 5 7/8 | 6 3/16 | 6 1/2 | 6 3/16 | 7 1/16 | 8 1/8 | — |
| 8 | 5 1/16 | 6 | 6 1/8 | 6 1/4 | 6 1/2 | 6 3/4 | 7 | 7 1/16 | 7 1/8 | 8 | 8 1/16 | 9 1/4 | 10 1/8 |

Technical Information

Design Applications (continued)

Table 11 — Standard Dimensions and Weights of Piping Materials and Conduit

| MECHANICAL (SCHEDULE 40) | | |
|------------------------------|-----------------|---------------------|
| NOMINAL STD. PIPE SIZE (IN.) | PIPE O.D. (IN.) | COUPLING O.D. (IN.) |
| 1/2 | .84 | 1.06 |
| 3/4 | 1.05 | 1.31 |
| 1 | 1.32 | 1.58 |
| 1 1/4 | 1.66 | 1.90 |
| 1 1/2 | 1.90 | 2.20 |
| 2 | 2.38 | 2.75 |
| 2 1/2 | 2.88 | 3.25 |
| 3 | 3.50 | 4.00 |
| 3 1/2 | 4.00 | 4.63 |
| 4 | 4.50 | 5.00 |
| 5 | 5.56 | 6.30 |
| 6 | 6.63 | 7.39 |
| 8 | 8.63 | 9.23 |
| 10 | 10.75 | — |
| 12 | 12.75 | — |
| 14 | 14.00 | — |
| 16 | 16.00 | — |
| 18 | 18.00 | — |
| 20 | 20.00 | — |
| 22 | 22.00 | — |
| 24 | 24.00 | — |
| 26 | 26.00 | — |
| 28 | 28.00 | — |
| 30 | 30.00 | — |

| NOMINAL CONDUIT SIZE (IN.) | ELECTRICAL CONDUIT | |
|----------------------------|--------------------------------|------------------------------------|
| | RIGID STEEL CONDUIT O.D. (IN.) | THIN WALL (EMT) CONDUIT O.D. (IN.) |
| 1/2 | .84 | .71 |
| 3/4 | 1.05 | .92 |
| 1 | 1.32 | 1.16 |
| 1 1/4 | 1.66 | 1.51 |
| 2 | 2.38 | 2.20 |
| 2 1/2 | 2.88 | 2.88 |
| 3 | 3.50 | 3.50 |
| 4 | 4.50 | 4.50 |

* Includes weight of heaviest conductor combination

Technical Information

Table 12 — Extra Strong Pipe (Schedule 80)

| A.S.A. B36.10 SCHEDULE NOS. AND NOMINAL WALL THICKNESS DESIGNATIONS | NOMINAL PIPE SIZE (IN.) | OUTSIDE DIAMETER (IN.) | WALL THICKNESS (IN.) | INSIDE DIAMETER (IN.) |
|---|-------------------------|------------------------|----------------------|-----------------------|
| EXTRA STRONG PIPE AND SCHEDULE 80 PIPE (THROUGH 8") | 3/8 | .675 | .126 | .423 |
| | 1/2 | .840 | .147 | .546 |
| | 3/4 | 1.050 | .154 | .742 |
| | 1 | 1.315 | .179 | .957 |
| | 1 1/4 | 1.660 | .191 | 1.278 |
| | 1 1/2 | 1.900 | .200 | 1.500 |
| | 2 | 2.375 | .218 | 1.939 |
| | 2 1/2 | 2.875 | .276 | 2.323 |
| | 3 | 3.500 | .300 | 2.900 |
| | 3 1/2 | 4.000 | .318 | 3.364 |
| | 4 | 4.500 | .337 | 3.826 |
| | 5 | 5.563 | .375 | 4.813 |
| | 6 | 6.625 | .432 | 5.761 |
| EXTRA STRONG PIPE (10" THROUGH 24" OD) | 8 | 8.625 | .500 | 7.625 |
| | 10 | 10.750 | .500 | 9.750 |
| | 12 | 12.750 | .500 | 11.750 |
| | 14 OD | 14.000 | .500 | 13.000 |
| | 16 OD | 16.000 | .500 | 15.000 |
| | 18 OD | 18.000 | .500 | 17.000 |
| | 20 OD | 20.000 | .500 | 19.000 |
| SCHEDULE 80 PIPE (10" THROUGH 24" OD) | 24 OD | 24.000 | .500 | 23.000 |
| | 10 | 10.750 | .593 | 9.564 |
| | 12 | 12.750 | .687 | 11.376 |
| | 14 OD | 14.000 | .750 | 12.500 |
| | 16 OD | 16.000 | .842 | 14.314 |
| 18 OD | 18.000 | .937 | 16.126 | |
| 20 OD | 20.000 | 1.031 | 17.938 | |
| 24 OD | 24.000 | 1.218 | 21.564 | |

Table 13 — Pipe Covering Weights Thickness (Intended as Guide Only) and Weight of Calcium Silicate Covering

| NOMINAL PIPE SIZE | 260° THICK. (IN.) | 360° THICK. (IN.) | 440° THICK. (IN.) | 525° THICK. (IN.) | 600° THICK. (IN.) | 700° THICK. (IN.) | 800° THICK. (IN.) |
|-------------------|-------------------|-------------------|-------------------|-------------------|-------------------|-------------------|-------------------|
| 1 | 1 | 1 | 1 | 1 | 1 1/2 | 1 1/2 | 1 1/2 |
| 1 1/4 | 1 | 1 | 1 | 1 | 1 1/2 | 1 1/2 | 2 |
| 1 1/2 | 1 | 1 | 1 | 1 | 1 1/2 | 1 1/2 | 2 |
| 2 | 1 | 1 | 1 | 1 1/2 | 1 1/2 | 2 | 2 |
| 2 1/2 | 1 | 1 | 1 | 1 1/2 | 1 1/2 | 2 | 2 1/2 |
| 3 | 1 | 1 | 1 | 1 1/2 | 1 1/2 | 2 | 2 1/2 |
| 3 1/2 | 1 | 1 | 1 1/2 | 1 1/2 | 2 | 2 | 2 1/2 |
| 4 | 1 | 1 | 1 1/2 | 1 1/2 | 2 | 2 | 2 1/2 |
| 5 | 1 | 1 | 1 1/2 | 1 1/2 | 2 | 2 | 2 1/2 |
| 6 | 1 1/2 | 1 1/2 | 1 1/2 | 1 1/2 | 2 | 2 | 2 1/2 |
| 8 | 1 1/2 | 1 1/2 | 1 1/2 | 1 1/2 | 2 | 2 | 2 1/2 |

Technical Information

Design Applications (continued)

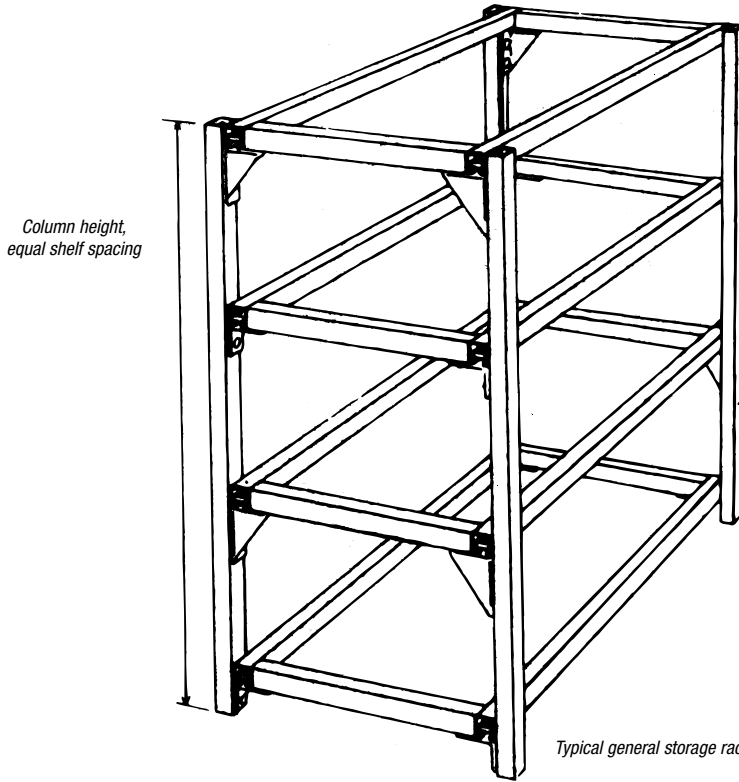

- General Storage Racks
- Pallet Racks
- Barrel Racks
- Bulk Furniture Racks
- Cable Racks
- Bar Stock Racks
- Display Racks
- Special Purpose Racks
- For Uniform Loads on Horizontal Members, See Table 3 (pages B-200–B-210)

Table 14 — Column Loading for Rack Construction

| COLUM HEIGHT | CAT. NO. | ALLOWABLE LOAD IN LBS. PER UPRIGHT | | | | | | | | |
|--------------|----------|------------------------------------|-------|-------|-------|-------|-------|-------|-------|-------|
| | | NUMBER OF SHELVES PER UPRIGHT | | | | | | | | |
| | | 2 | 3 | 4 | 5 | 6 | 7 | 8 | 9 | 10 |
| 6' | A-1200 | 2,237 | 1,925 | 1,650 | 1,437 | 1,290 | — | — | — | — |
| | A-1202 | 4,170 | 3,580 | 3,100 | 2,730 | 2,450 | — | — | — | — |
| | B-1400 | 800 | 820 | 790 | 700 | 630 | — | — | — | — |
| | B-1402 | 1,930 | 1,700 | 1,500 | 1,300 | 1,190 | — | — | — | — |
| 7' | A-1200 | 2,150 | 1,850 | 1,630 | 1,425 | 1,280 | 1,150 | — | — | — |
| | A-1202 | 4,000 | 3,525 | 3,000 | 2,700 | 2,430 | 2,200 | — | — | — |
| | B-1400 | 650 | 790 | 760 | 685 | 615 | 550 | — | — | — |
| | B-1402 | 1,800 | 1,650 | 1,450 | 1,300 | 1,180 | 750 | — | — | — |
| 8' | A-1200 | 2,000 | 1,820 | 1,600 | 1,400 | 1,250 | 1,150 | 1,050 | — | — |
| | A-1202 | 3,900 | 3,475 | 3,000 | 2,700 | 2,400 | 2,185 | 2,000 | — | — |
| | B-1400 | 580 | 750 | 730 | 660 | 610 | 540 | 510 | — | — |
| | B-1402 | 1,650 | 1,610 | 1,450 | 1,300 | 1,160 | 940 | 970 | — | — |
| 9' | A-1200 | 1,950 | 1,780 | 1,575 | 1,400 | 1,250 | 1,130 | 1,030 | 950 | — |
| | A-1202 | 3,800 | 3,400 | 3,020 | 2,675 | 2,400 | 2,180 | 1,975 | 1,800 | — |
| | B-1400 | — | 600 | 665 | 600 | 580 | 540 | 500 | 475 | — |
| | B-1402 | 1,500 | 1,500 | 1,430 | 1,275 | 1,160 | 1,000 | 900 | 800 | — |
| 10' | A-1200 | 1,870 | 1,700 | 1,500 | 1,300 | 1,200 | 1,100 | 1,000 | 900 | 800 |
| | A-1202 | 3,600 | 3,300 | 3,000 | 2,650 | 2,350 | 2,000 | 1,975 | 1,800 | 1,650 |
| | B-1400 | — | 550 | 650 | 625 | 580 | 535 | 490 | 450 | 425 |
| | B-1402 | 1,450 | 1,480 | 1,400 | 1,250 | 1,140 | 1,040 | 960 | 885 | 825 |

Technical Information

Federal Specifications (WW-H-171)/ Manufacturers Society Specifications (MSS SP69)



C-710
Adj. Steel Clevis
Sizes 3/4" through 20" IPS
Federal Type 1
SP69 Type 1



C-726
Steel Double Bolt Pipe Clamp
Sizes 1 1/2" through 24" IPS
Federal Type 3
SP69 Type 3

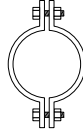

C-725
Steel Pipe Clamp
Sizes 1 1/2" through 24" IPS
Federal Type 4
SP69 Type 4



CF-710
Adj. Steel Band Hanger
Sizes 1/2" through 8"
IPS 3/4" through 4" tube
Federal Type 7

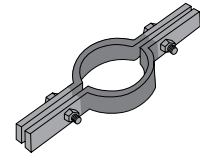

C-720/CT-720
Extension Pipe or Riser Clamp
Sizes 3/4" through 20"
IPS 1/2" through 6" tube
Federal Type 8
SP69 Type 8



C-727/CT-727
Adj. Swivel Ring Hanger
Sizes 1/2" through 8" IPS
1/2" through 4" tube
Federal Type 10
SP69 Type 10

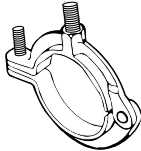

M-718/MT-718
MI Split Pipe Ring
w/wo turnbuckle adj.
Sizes 1/2" through 8" IPS
1/2" through 4" tube
Federal Type 11
SP69 Type 12



CL-710
Light-Duty Clevis Hanger
Sizes 1/2" through 4"
Federal Type 12



F-112
Forged Steel Turnbuckle
Sizes 3/8" through 1 1/2" rod
Federal Type 13
SP69 Type 13



F-111
Forged Steel Clevis
Sizes 3/8" through 1 1/2" rod
Federal Type 14
SP69 Type 13

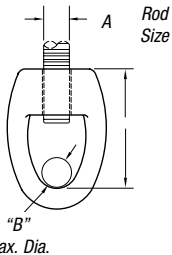

M-117
MI Socket only for
S Split Ring Hanger
Sizes 3/8" through 1 1/2" Rod
Federal Type 16
SP69 Type 16



E-120-A
Forged Steel Weldless Eye Nut
Sizes 3/8" through 1 1/2" rod
Federal Type 17
SP69 Type 17

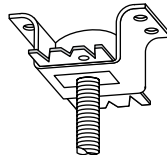

452
Steel Concrete Insert
Federal Type 19
SP69 Type 18

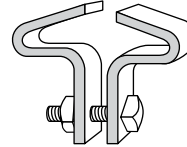

C-755 T/C-757 T
Center I-Beam Clamp
Federal Type 21
SP69 Type 21

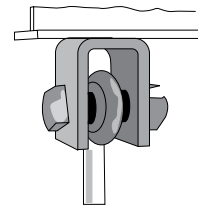

C-780
Welded attachment as
shown or inverted less bolt
Federal Type 22
SP69 Type 22



M-775-L/C-775-L
MI or Steel C-Clamp
Sizes 3/8" through 1 1/2"
Federal Type 23
SP69 Type 23



H-115
U-Bolt
Sizes 1/2" through 24" IPS
Federal Type 24
SP69 Type 24

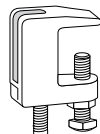

M-778
Top Beam C-Clamp
Sizes 3/8" through 3/4" rod
SP69 Type 19

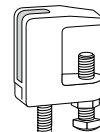

M-777
Junior Top Beam C-Clamp
Sizes 3/8" through 1/2" rod
SP69 Type 18

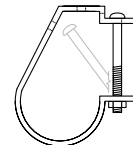

C-711
"J" Pipe Hanger
Sizes 1/2" through 8" pipe
SP69 Type 5

Technical Information

Federal Specifications (WW-H-171)/ Manufacturers Society Specifications (MSS SP69) (continued)



C-704-A
Offset J-Hook
Sizes ½" through 3" IPS
Federal Type 27



M-732-H
I-Beam w/Eye Nut
Federal w/o links Type 28
Federal w/links Type 29
SP69 Type 28



M-732/M-732 Ext
I-Beam Clamp
w/Swing Nut
Sizes ¾" through ¾" Rod
Federal Type 30
SP69 Type 30

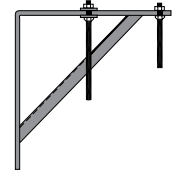

C-736
Light Welded Steel Bracket
Federal Type 32
SP69 Type 31

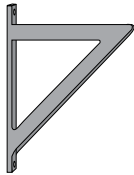

C-739-H
Heavy Welded Steel Bracket
Max. Load 3,000 lbs.
Federal Type 34
SP69 Type 33

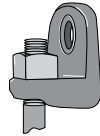

M-750
Side Beam Bracket
Sizes ¾" through ¾" Rod
Federal Type 35
SP69 Type 34



C-785-A
Pipe Stanchion Saddle
Sizes 4" through 36" IPS
Federal Type 38
SP69 Type 37



C-786
Adj. Pipe Saddle Support
Sizes 2½" through 36" IPS
Federal Type 39
SP69 Type 38

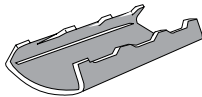

C-789
Steel Pipe Covering
Protection Saddle
Sizes up to and including
10" IPS
Federal Type 40A
SP69 Type 39

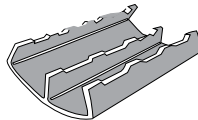

C-789-AL
Steel Pipe Covering
Protection Saddle
Sizes 12" IPS and larger
Federal Type 40B
SP69 Type 39

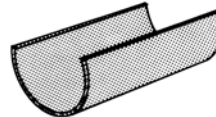

C-790
Insulation Protection Shield
for Vapor sealed pipe lines and
insulated copper tubing
Sizes ¾" through 12" IPS
Federal Type 41
SP69 Type 40



RC-729A
Single Pipe Roll
Sizes 1" through 24" IPS
Federal Type 42
SP69 Type 41



C-729
Adj. Roller Hanger
Sizes 1" through 20" IPS
Federal Type 44
SP69 Type 43



S-730-C
Pipe Roll Complete
Federal Type 45
SP69 Type 44



S-730-D
Adj. Pipe Roll & Base
Federal Type 47
SP69 Type 46