

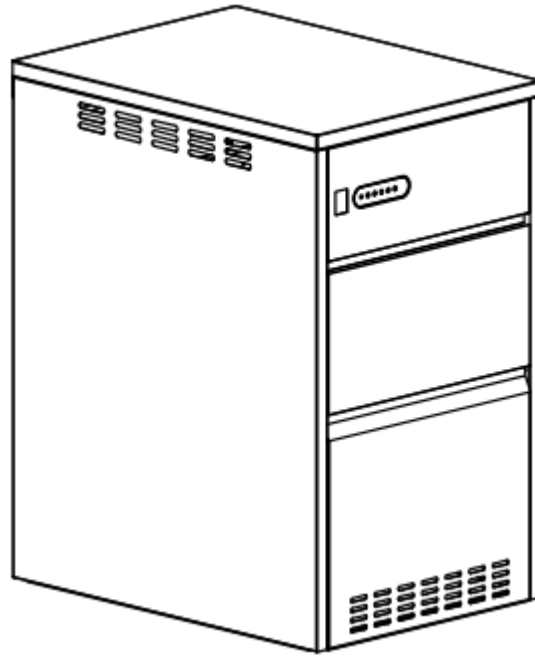

Automatic Flake Ice Maker

Instruction Manual



SZB-20

SZB-40

Thank you for selecting SPT Automatic Flake Ice Maker. Please follow and save this instruction manual.

Content

Features.....	1
Before First Use.....	1
Structure.....	2
Accessories.....	2
Installation Instructions.....	3
Maintenance.....	3
Specifications.....	3
Troubleshooting.....	4
Circuit Diagram.....	5
Warranty	

Features:

- Stainless Steel front panel and flat door
- LED indicators on operation board
- Internal water storage tank for water preservation
- Insulated ice storage cabinet
- Gravity based draining
- Auto-cleaning function: Every time the unit is turned on, it will go through an auto-cleaning process. During this process, the 3 indicator lights (“RUN”, “FAULT” and “WATER LOW”) will flash at the same time. This process takes about one minute
- Overheat protection: If the internal temperature is above 164°F, the unit will shut-off automatically with “FAULT” and “WATER LOW” lights flashing and the “RUN” light staying solid. The unit will resume operation when the internal temperature drops below 158°F.

Before First Use:

1. The unit should not be tilted more than 45° during transportation and unpacking. Do not turn the ice maker upside-down as this may damage the compressor or refrigeration system.
2. The flake ice maker should be placed on a flat, level and firm surface away from any heat sources or corrosive gas.
3. This unit is for Free-Standing use only. It vents from the sides. Do not place anything above the unit or install under-counter. There must be at least 3 feet of clearance on each side and at least 6-inches behind the unit.
4. Wait 12 hours after installation before turning on the ice maker.
5. Unit is designed for use in a 3-prong grounded outlet. Do not use adapters to bypass this feature.
6. If the power cord is damaged, it must be replaced by a qualified person to avoid electrical hazards.
7. Flake ice maker should be connected to a drinkable water supply only.
8. This appliance is not intended for use by children or other persons without assistance or supervision if their physical, sensory or mental capabilities prevent them from using it safely. Children should be supervised to ensure that they do not play with the appliance.
9. Please do not place the machine near flammable materials.
10. Use only new hose sets with the appliance. Do not use previously used hoses.

Structure:

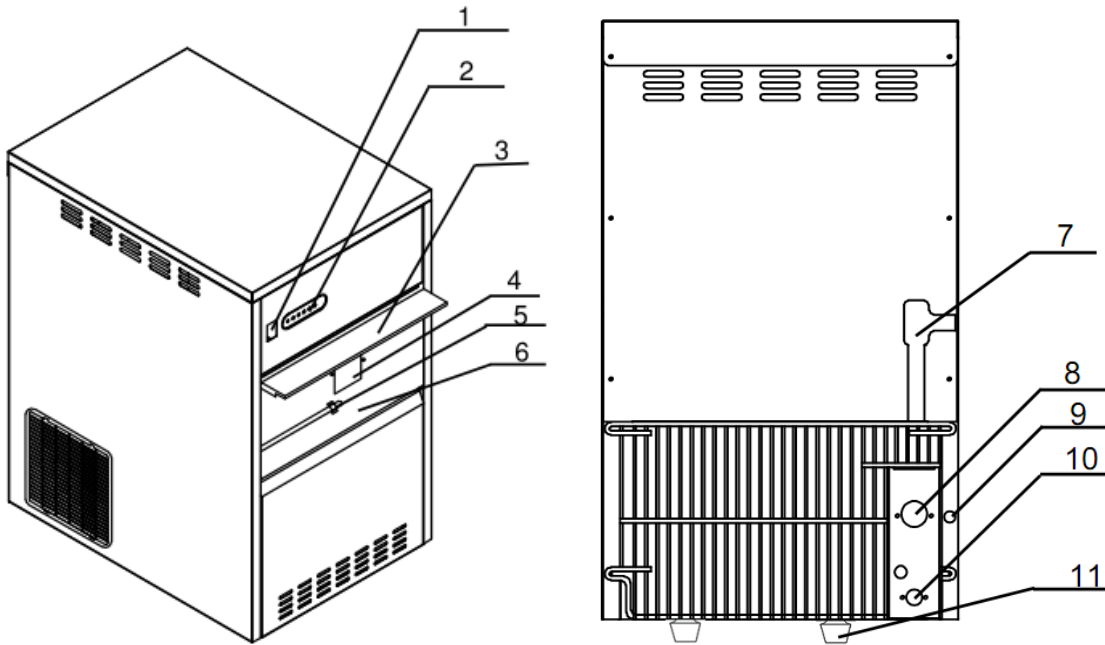

1. Power Switch

2. Display Panel

3. Ice Maker Door

4. Ice Outlet

5. Ice Full Sensor

6. Ice Storage Cabinet

7. Power Cord

8. Water Inlet

9. Drain Spout

10. Drain Outlet

11. Foot

Accessories :



Water Inlet Tube

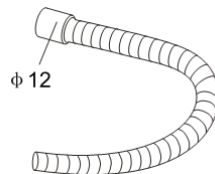

Water Drainage Tube



Squeeze Hose Clamp



Ice Shovel

Installation Instructions:

1. Unpack the ice maker and take out the attached documents and included parts, such as the water inlet and drain tubes, ice shovel and gaskets.
2. Install in the proper free-standing location. (See Before First Use)
3. Connect one end of the drain tube to the water outlet connector on the ice maker. Connect the other side to your drain or external condensation pump. (purchased separately from most hardware or plumbing stores)
4. Connect one end of the water inlet tube to the ice maker with the 3/4" screw type connector. Connect the other end to your water supply. The water pressure of the water supply pipe is 1.5 to 3 bar. (22 to 44 PSI)
5. Insert the plug into the power supply socket.

Maintenance:

- 1: If the compressor stops for any reason like water shortage, ice full, power off or loss of power; do not restart it right away. Please wait about 5-minutes.
- 2: Check the water inlet and drain line connectors regularly for any signs of cracks or wear.
- 3: If the ice maker will be unused for a long period of time, please switch off the power switch and wipe the inner liner of the ice storage container. Also, drain the internal water tank via Drain Spout. (Part No. 9)
- 4: Unplug the unit by holding the plug, not the cord wire.

Specifications:

Model	Ice Making Capacity* (lbs/24hrs)	Rated Voltage	Power Consumption (W)	Ice Storage Capacity (lbs)	Dimensions (in)
SZB-20	66	110-120V / 60Hz	270	7	13 X 19.8 X 23.8
SZB-40	88		380	12	15.7 X 21.4 X 27.6

* Based on water temperature at 50°F and ambient temperature at 59°F.

Troubleshooting:

Trouble	Causes	Solutions
The ice maker does not work.	<ol style="list-style-type: none"> 1. The voltage is too low. 2. The ambient temperature is too low (lower than 41°F) 	<ol style="list-style-type: none"> 1. Turn off the ice maker and restart it when the voltage is normal. 2. Use it when the ambient temperature is higher than 41°F.
“WATER LOW” indicator light is on.	<ol style="list-style-type: none"> 1. Water shortage from the water supply. 2. Water valve is damaged. 3. Water pressure is too low. 	<ol style="list-style-type: none"> 1. Check the water supply. 2. Check the water valve. 3. Water pressure should be higher than 1.5 bar.
Compressor does not work.	<ol style="list-style-type: none"> 1. Water shortage. 2. Ice is full. 	<ol style="list-style-type: none"> 1. Check the water supply system, including water valve and water tubes. 2. Remove the ice from the ice bucket.
Compressor works, but no ice is made.	<ol style="list-style-type: none"> 1. Refrigerant leakage. 2. The refrigeration system is blocked. 	<ol style="list-style-type: none"> 1. Contact refrigerator repair shops for recharging refrigerant. 2. Check whether the ventilation fan is working.
“FAULT” indicator light stays on.	<ol style="list-style-type: none"> 1. Flake ice motor is damaged. 2. Fan motor is damaged. 	Contact Sunpentown.
“ICE FULL” indicator light flashes.	The ice full sensor is loose or damaged.	Replace the ice full sensor.
“WATER LOW” and “ICE FULL” indicator lights flashes at the same time.	<ol style="list-style-type: none"> 1. Water inlet is clogged. 2. Ambient temperature is too low. 	Turn off the unit and turn it back on when the ambient temperature is high than 41°F.
“FAULT” and “WATER LOW” lights flash and the “RUN” light stays solid.	The unit is overheated.	The internal temperature is above 164°F. The unit will resume operation when the internal temperature drops below 158°F.

Please contact Sunpentown if the troubleshooting doesn't work

Circuit Diagram

Circuit Diagram

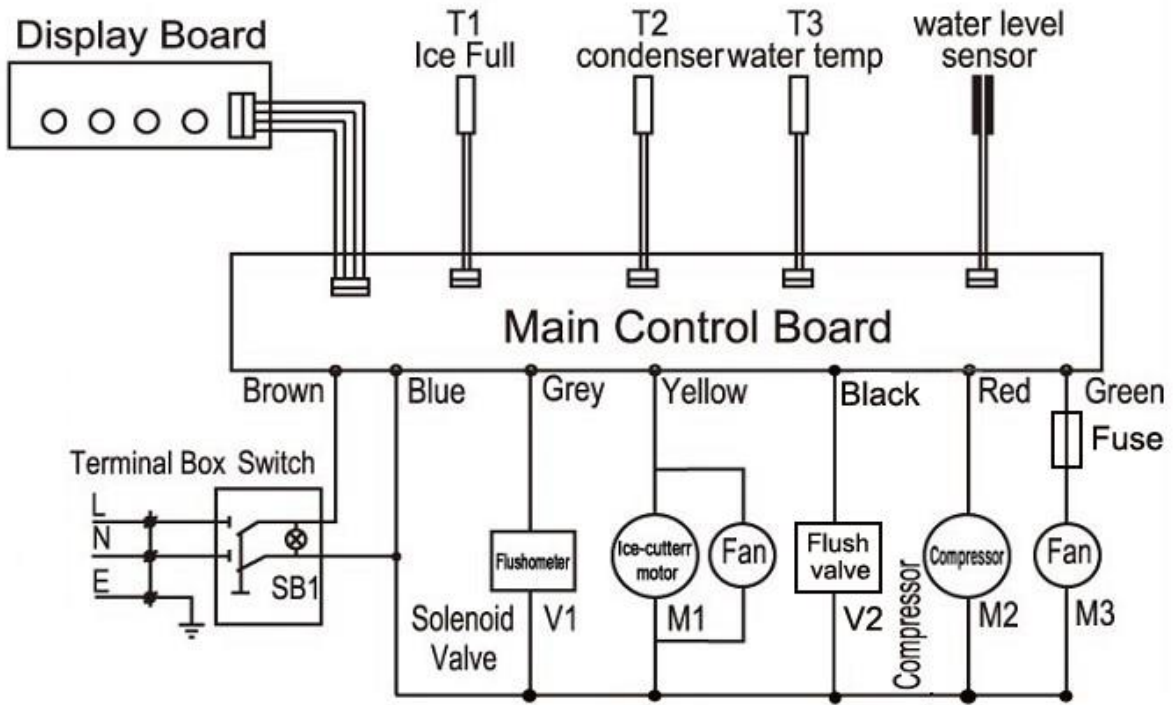



Your Guarantee

If this product is found to be faulty as a result of faulty materials or workmanship within one year from date of purchase, it will be repaired free of charge.

This guarantee is subject to the following terms:

- Sunpentown must be notified of the fault.
- Proof of purchase must be presented to Sunpentown's nominated representative.
- The warranty will be void if the product is modified, misused or repaired by an unauthorized person.
- The warranty after repair will not be extended beyond the original one-year period.
- All replacement parts will be new or reconditioned.
- Parts, which are replaced, become the property of Sunpentown.
- The warranty applies for the use of the product in the USA only.

What is NOT COVERED:

- Warranty does not include freight charges.
- Incidental or consequential damage caused by possible defects with this product.
- Damage to product caused by improper power supply voltage, accident, fire, floods or acts of nature.

This GUARANTEE is in addition to your Statutory Rights

SUNPENTOWN INTERNATIONAL INC.

Tel: 800-330-0388 Fax: 626-336-7116

14625 Clark Ave., City of Industry CA 91745

service@sunpentown.com

www.sunpentown.com