

The Luxury of Outdoor Living



Lido Chair and Ottoman Item#: 62408



ATTACH YOUR RECEIPT HERE

Keep a copy of your proof of purchase or order confirmation which will be needed if you need to contact us about warranty coverage.

Purchase Date: _____



SAVE THESE INSTRUCTIONS FOR FUTURE REFERENCE.



Questions, problems, missing parts?

Before returning to your retailer, our exceptional customer service is available.

Call us toll-free at **(866) 985-7877**, email us at cservice@welltraveled.net, or go online and live chat at www.wtliving.com. Our hours are: **9 a.m. – 6 p.m., EST, Monday – Friday**



BEFORE YOU BEGIN

Before beginning assembly, make sure all parts are present. Compare parts received with the “Parts List.” If any part is missing or damaged, do NOT attempt to assemble the product. Please read and understand this entire manual before attempting to assemble, operate or install this product. If you have any questions regarding the product, please call us toll-free at **(866) 985-7877**, email us at cservice@welltraveled.net, or go online and live chat at www.wtliving.com. Our hours are: **9 a.m. – 6 p.m., EST, Monday – Friday**



GENERAL INFORMATION

Your new chair and ottoman set are made from the finest materials available. It should provide many years of enjoyment with minimal care.

Keep your chair and ottoman set clean. For best results, clean with a soft, damp cloth. If you use furniture covers, always make sure the chair and ottoman set are clean and completely dry before covering, as mold may form in dark, wet places. Remove cushions prior to covering and store them in a dry, temperature controlled place. Check the connectors on your chair and ottoman set regularly to make sure they are secure.

The weight limit for one seat of the chair is 250 lbs.



SAFETY INFORMATION

WARNING

DO NOT stand or allow children to stand on the assembled product. Make sure connectors are securely in place. Perform periodic checks to make sure the connectors are secure and adjust if needed.

CAUTION

READ all instructions before beginning assembly. Failure to do so may result in faulty assembly and potential injury. Assemble the item on a soft, non-abrasive surface such as carpet or cardboard to avoid damaging the item.

SUGGESTIONS

Use at least two people for assembly. Assemble on a flat, soft ground. Do not tighten bolts fully until parts all connected.



CHAIR PARTS

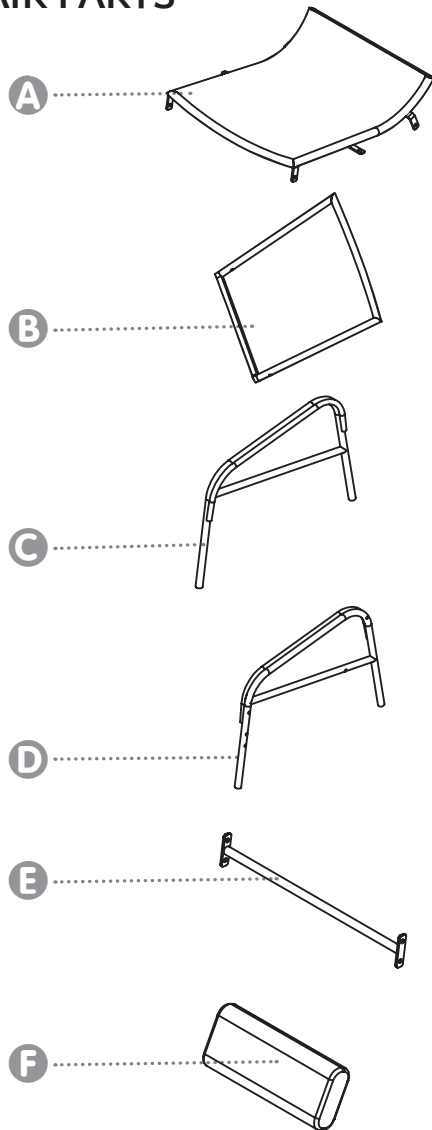

PART	DESCRIPTION	QUANTITY
A	Seat	1
B	Back	1
C	Left Arm	1
D	Right Arm	1
E	Bar	1
F	Lumbar Cushion	1



HARDWARE CONTENTS

CHAIR PARTS



J
M6x40 Bolt
Qty: 4



K
M6x20 Bolt
Qty: 10



L
Washer
Qty: 14



M
Allen Wrench
Qty: 1

OTTOMAN PARTS

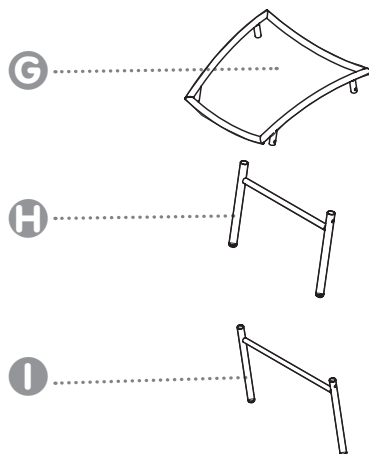

OTTOMAN PARTS



N
M6x35 Bolt
Qty: 4



O
Washer
Qty: 8



P
Spacer
Qty: 4



Q
Nut
Qty: 4

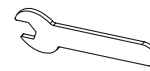

R
Wrench
Qty: 1

ASSEMBLY



1 Attach Chair Seat **A** to Chair Back **B** using 2 - M6x40 Bolts **J** and Washers **L**. Tighten with Allen Wrench **M**.



Hardware Used: M6x40 Bolt x 2
Washer x 2

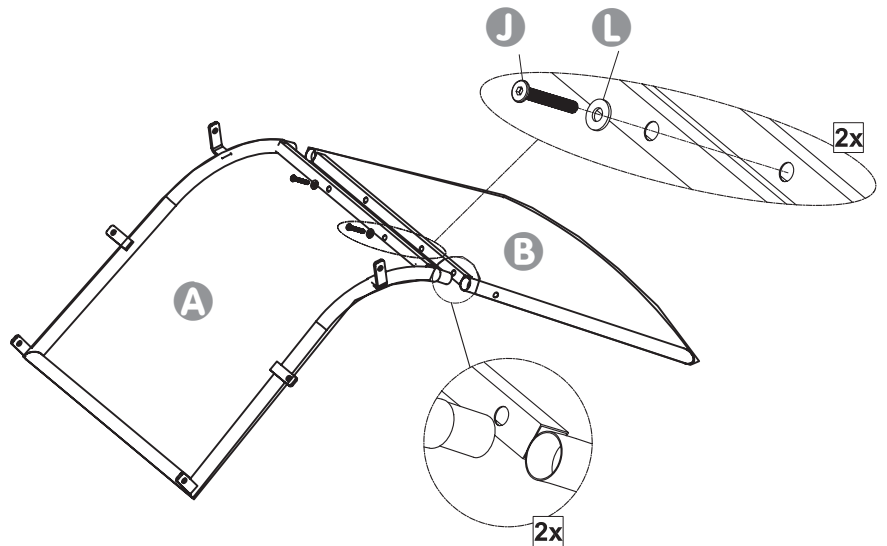

2 Attach Right and Left Arms **C** & **D** to assembled Seat/Back using M6x20 Bolts **K** and Washers **L** and M6x40 Bolts **J** and Washers **L**. Tighten with Allen Wrench **M**.



Hardware Used: M6x40 Bolt x 2
M6x20 Bolt x 6
Washer x 8

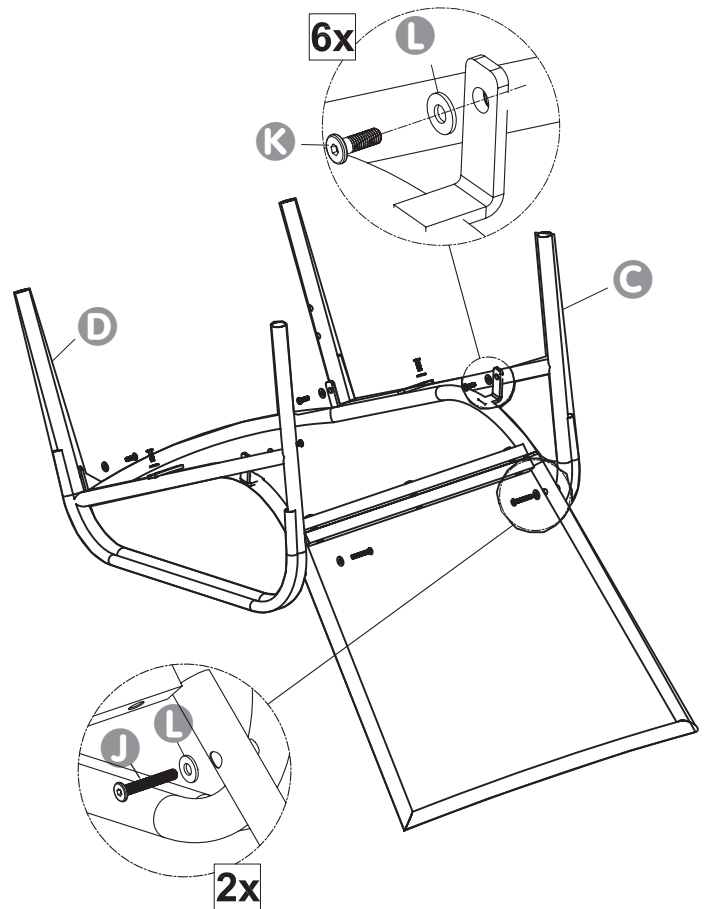

3 Attach the **Bar E** to the assembled chair using **M6x20 Bolt K** and **Washers L** on each side. Tighten with **Allen Wrench M**.



Hardware Used: M6x20 Bolt x 4
Washer x 4

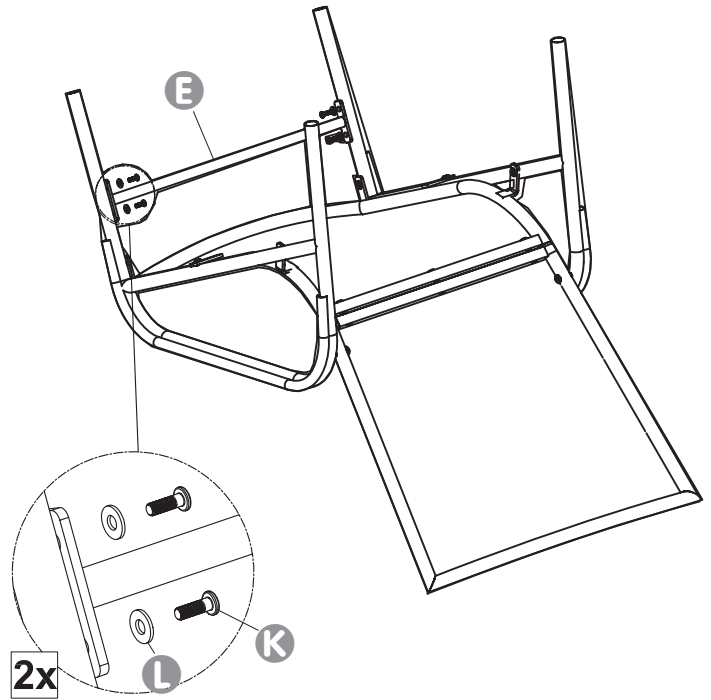

4 Turn the assembled chair upright and rest on a flat, level surface. Place the **Lumbar Cushion F** in the chair and enjoy your new seating!

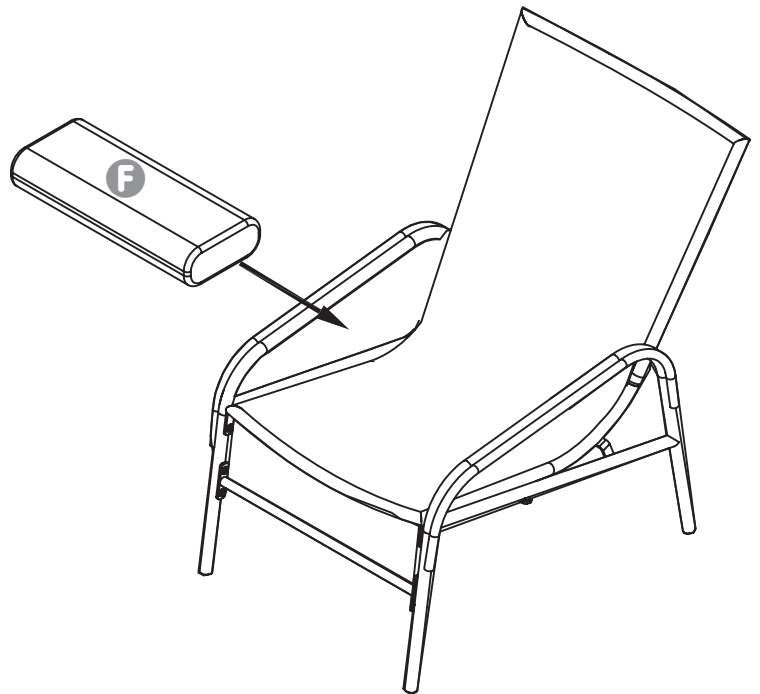

5 Attach **Front Leg H** and **Back Leg I** to **Ottoman Top G**. Slide **M6x35 Bolt N** through **Washer O** and then into **Spacer P**. Slide Bolt through hole in **Ottoman Top** and **Leg** and secure with **Washer Q** and **Nut R**. Tighten with **Wrench S** and **Allen Wrench M**.



Hardware Used: M6x35 Bolt x 4

Washer x 8

Spacer x 4



Nut x 4

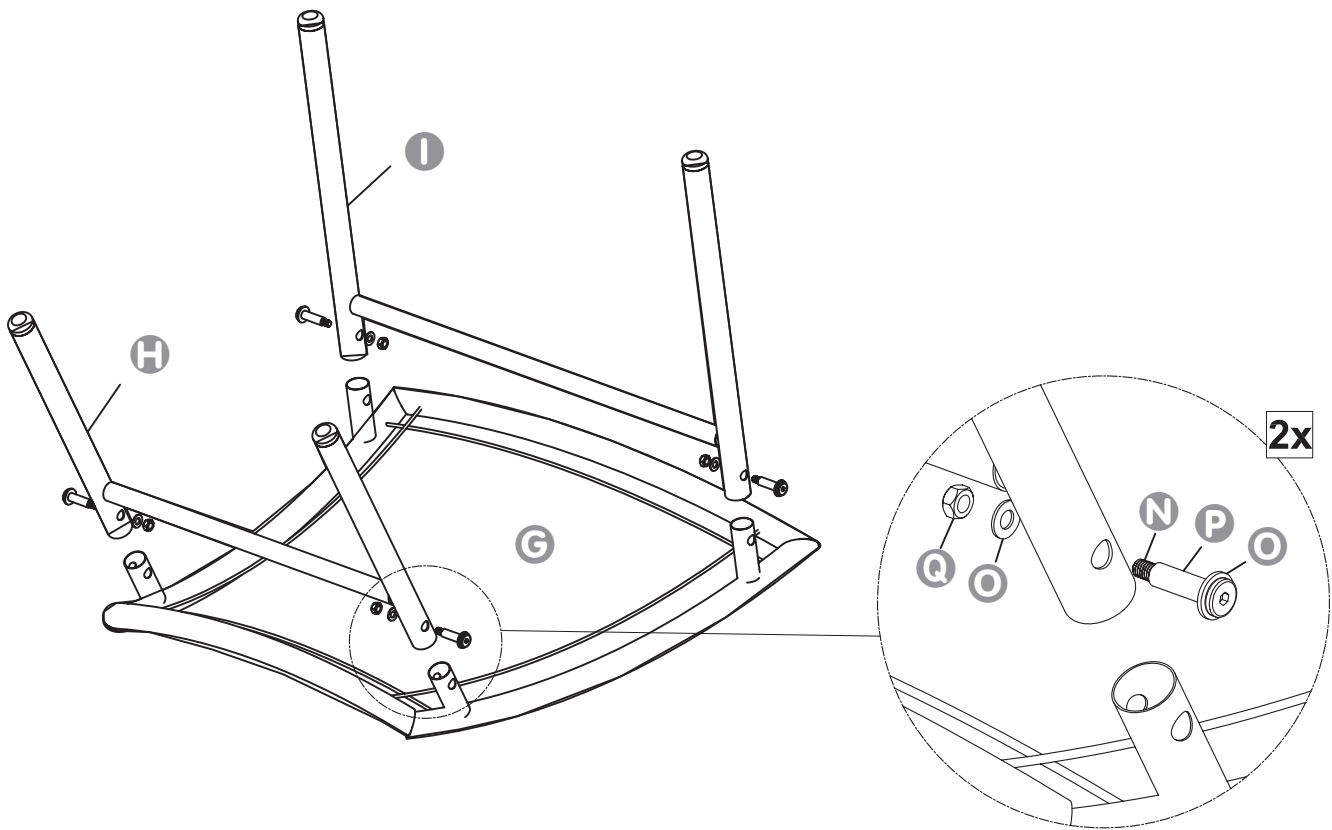



1 YEAR LIMITED WARRANTY

Customers in the Continental US

All components are warranted for a period of 1 year after date of purchase by the original owner against defects in materials and workmanship under normal use. This warranty does NOT cover normal wear and weathering, assembly and/or maintenance OR use in a commercial application if model is not designated as a commercial model. At Well Traveled Living's sole discretion, products under warranty will be repaired and/or replaced at no charge to the customer. Any returns sent back to Well Traveled Living must be sent via prepaid freight and in the original retail packaging.

For warranty service contact Well Traveled Living at the address, phone numbers or internet site and email listed in this owner's manual. Be sure to have your sales receipt, date of purchase and catalogue/model numbers available when calling. All warranty service will be coordinated by the Well Traveled Living's, Amelia Island, Florida service center.

This warranty is extended only to the original purchaser. Proof of purchase will be required before warranty service is rendered. The sales receipt is the only valid proof of purchase. This warranty only covers failures due to defects in materials or workmanship which occur during normal use. Failures and/or damage which result from accident, negligence, misuse, abuse, neglect, mishandling, alteration or modification, failure to maintain, improper assembly or maintenance, service by unauthorized agency or use of unauthorized components or damage that is attributable to acts of God are NOT covered.

This limited warranty gives you specific legal rights and you may also have other rights which vary from jurisdiction to jurisdiction. The provisions of the United Nations Convention on Contracts for the Sales of Goods shall not apply to this limited warranty or the sale of products covered by this limited warranty.

- THERE ARE NO EXPRESS WARRANTIES EXCEPT AS LISTED ABOVE
- PURCHASER ASSUMES ALL RISKS IN THE ASSEMBLY AND OPERATION OF THIS UNIT
- FAILURE TO FOLLOW WARNINGS AND OPERATIONAL INSTRUCTIONS CONTAINED IN THIS MANUAL CAN RESULT IN SEVERE PROPERTY DAMAGE AND/OR PERSONAL INJURY
- IN NO EVENT WILL WELL TRAVELED LIVING, OR ITS DIRECTORS, OFFICERS OR AGENTS BE LIABLE TO THE PURCHASER OR ANY THIRD PARTY, WHETHER IN CONTRACT, IN TORT, OR ON ANY OTHER BASIS, FOR ANY INDIRECT, SPECIAL, PUNITIVE, EXEMPLARY, CONSEQUENTIAL, OR INCIDENTAL LOSS, COST, OR DAMAGE ARISING OUT OF OR IN CONNECTION WITH THE SALE, MAINTENANCE, USE, OR INABILITY TO USE THE PRODUCT, EVEN IF WELL TRAVELED LIVING OR ITS DIRECTORS, OFFICERS OR AGENTS HAVE BEEN ADVISED OF THE POSSIBILITY OF SUCH LOSSES, COSTS OR DAMAGES, OR IF SUCH LOSSES, COSTS, OR DAMAGES ARE FORESEEABLE. IN NO EVENT WILL WELL TRAVELED LIVING, OR ITS OFFICERS, DIRECTORS, OR AGENTS BE LIABLE FOR ANY DIRECT LOSSES, COSTS OR DAMAGES THAT EXCEED THE PURCHASE PRICE OF THE PRODUCT.
- SOME JURISDICTIONS DO NOT ALLOW THE EXCLUSION OR LIMITATION OF INCIDENTAL OR CONSEQUENTIAL DAMAGES, SO THE ABOVE LIMITATION OR EXCLUSION MAY NOT APPLY TO THE PURCHASER.



Important Notice

Do NOT return to place of purchase—for customer service and warranty issues contact our Customer Service Center at: (866) 985-7877, email us at cservice@welltraveled.net, or go online and live chat at www.wtliving.com. Our hours are: 9 a.m. – 6 p.m., EST, Monday – Friday



Distributed By:
Well Traveled Living
716 S 8th Street, Amelia Island, FL 32034
wtliving.com | cservice@welltraveled.net
(866) 985-7877