

TRIBEST<sup>®</sup>  
**Z STAR**<sup>™</sup>  
manual juicer

**Z-710**  
Instruction Manual

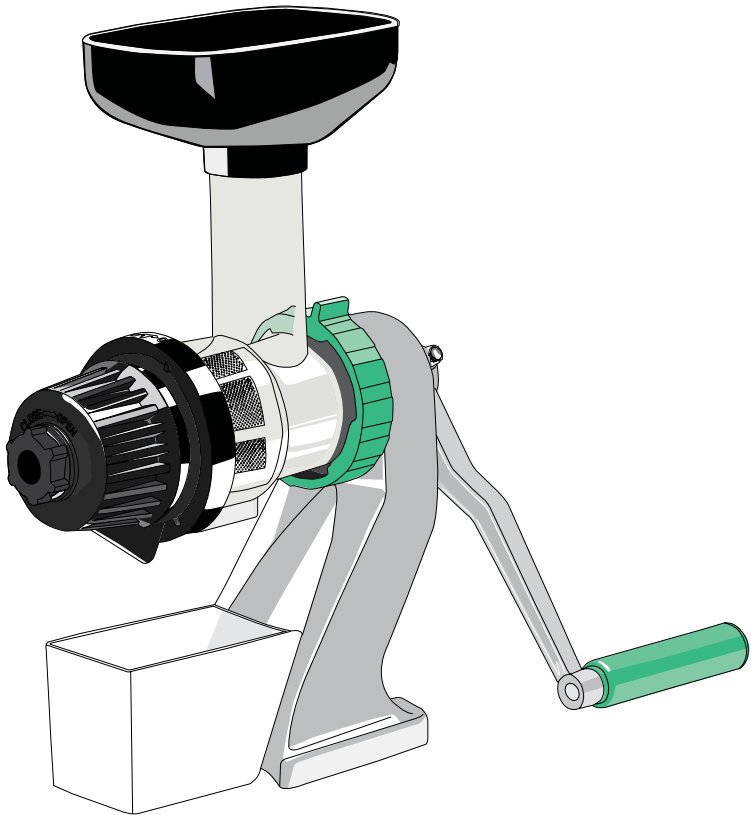

**SAVE THIS MANUAL - KEEP IT HANDY FOR QUICK REFERENCE**  
READ INSTRUCTIONS BEFORE USING



# TABLE OF CONTENTS

- Important Safety Instructions.....4
- Z-710 Manual Juicer Part Description.....5
- Z-710 Assembly and Operation.....6
- Disassembling the Z-710.....7
- Cleaning the Z-710.....7
- Troubleshooting.....8
- When You Need Service.....9
- Warranty.....10
- Product Specification.....12

## IMPORTANT SAFETY INSTRUCTIONS

1. Please read all instructions carefully.
2. Avoid contact with its moving parts while the Z-Star 710 is in operation.
3. Close supervision is necessary when any appliances are used by or near children.
4. Use only included accessories. Do not put any articles such as spoons, forks or knives into the Feeding Chute.
5. It is very dangerous to place fingers into the Feeding Chute while it is in operation. Make sure to always use the provided plunger to push down ingredients.
6. Please refer to “When You Need Service” in case your Z-710 is functioning abnormally.
7. Do not disassemble any parts other than those necessary for normal operation or cleaning of your Z-710.
8. Do not use hot or boiling water (above 104°F or 40°C) to clean the unit and parts. Deformation or other damages may result.
9. Do not use any bleach or harsh chemicals.
10. This machine is made for household use only.
11. Please refer to the “Assembly and Operation” before use.
12. Do not use the Z-710 for any other than its intended use.

**SAVE THESE INSTRUCTIONS**

# Z-710 MANUAL JUICER PART DESCRIPTION

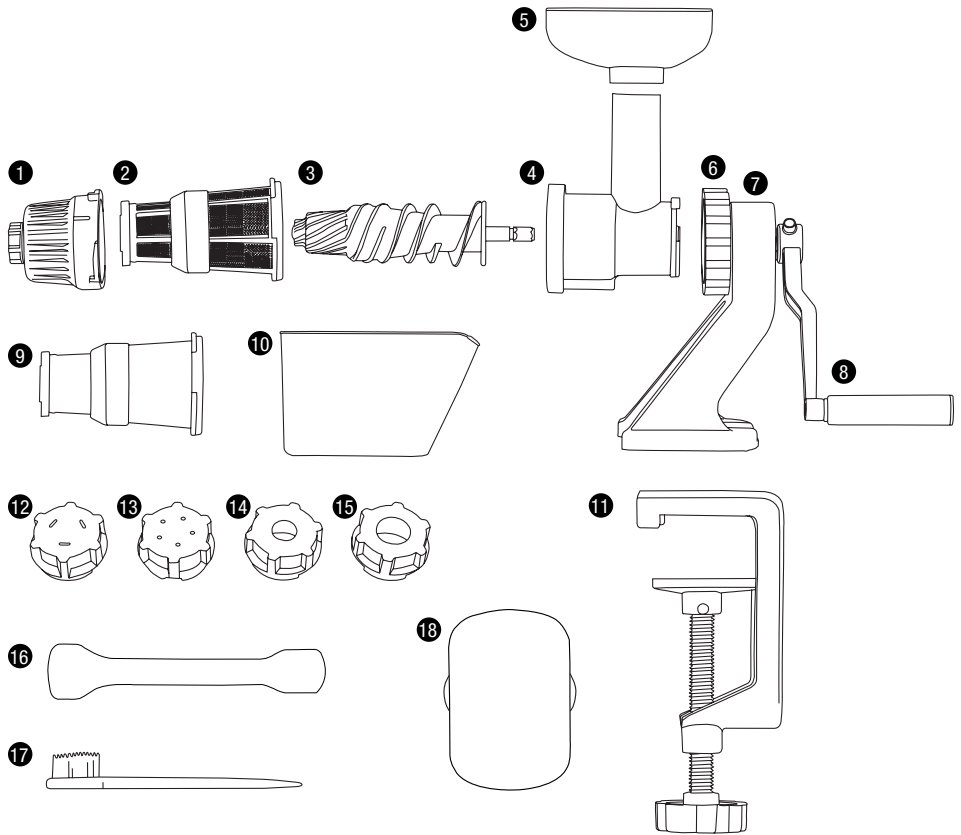

- 1. Screen Locking Cap
- 2. Juicing Screen
- 3. Auger
- 4. Auger Housing/Feeding Chute
- 5. Funnel
- 6. Auger Housing Retaining Ring
- 7. Base
- 8. Handle
- 9. Homogenizing Screen

- 10. Juice Container
- 11. Table Clamp
- 12. Fettuccini Nozzle
- 13. Spagetti Nozzle
- 14. Juicing Nozzle
- 15. Homogenizing Nozzle
- 16. Plastic Plunger
- 17. Cleaning Brush
- 18. Funnel Lid

# Z-710 MANUAL JUICER ASSEMBLY AND OPERATION

1. Place the base of the Z-710 at the edge of a counter or table top.
2. Fit the teeth of the Table Clamp into the groove in the Base of the Z-710. Secure the juicer to the counter or table top by tightening the screw.
3. Attach the Handle to the Base.
4. Insert the Auger into the Auger Housing and slide the Auger Housing into the Auger Housing Retaining Ring.
5. While holding the Auger Housing stable, turn the Auger Housing Retaining Ring clockwise (right) to lock the Auger Housing in place.
6. Pick the desired screen according to the foods that will be juiced and assemble as follows:

## **A. Juicing Screen: for juicing leafy greens, vegetables, and fruits**

Place the Juicing Screen into the front end of the Auger Housing. Make sure that the side labeled “UPPER” is facing upwards when inserted. Put the Screen Locking Cap over the screen and turn it counter-clockwise (left) to lock in place. Attach the Juicing Nozzle to the Screen Locking Cap by turning it counter-clockwise.

- Fibrous vegetables or fruits with seeds can be juiced by using the Homogenizing Nozzle instead of Juicing Nozzle.
- Small amounts of pulp can be in the juice depending on the produce used.

## **B. Homogenizing Screen: for making rice cakes/breadsticks, grinding (tomato, garlic, coffee beans, etc.), pasta noodles (spaghetti or fettuccini), or tofu.**

- a. Attach the Homogenizing Screen into the Auger Housing. Fasten and turn the Screen Locking Cap counter-clockwise to lock in place.
  - b. Place the desired nozzle into the Screen Locking Cap and turn it counter-clockwise.
- Use the Homogenizing Nozzle for homogenizing and grinding fresh garlic, onion, ginger or peppers.
  - Do not use the Homogenizing Nozzle for dried pepper, coffee beans etc.
7. Place the Funnel over the Feeding Chute of Auger Housing. Place the Juice Container underneath the specified Juice Outlets.
  8. Feed in fruits and vegetables in small amounts into the Funnel as you crank the Handle. Use the Plastic Plunger for assistance in pushing down food.
    - a. Food needs to be cut into smaller lengthwise pieces before juicing.
    - b. There may be some squeaking noises while operating, this is normal.

## DISASSEMBLING THE Z-710 MANUAL JUICER

1. Separate the Screen Locking Cap and Nozzle from the unit by turning clockwise.
2. Pull to remove the assembled Screen.
3. Turn the Auger Housing Retaining Ring counter-clockwise to separate it from the base.
4. Remove Auger from the Auger Housing.

## CLEANING THE Z-710 MANUAL JUICER

1. Be sure to clean and properly store the parts of the unit after every operation. When the Screens are not cleaned immediately after every use the residue may dry, blocking the holes from filtering and juicing.
2. Use lukewarm water with mild detergent. Do not use hot water or any harsh chemicals, such as bleach. It may result to deformation of parts.
3. To remove colored stains, soak parts in 70% white wine vinegar and 30% water.

# TROUBLESHOOTING

SYMPTOM	SOLUTION
Loud Noise	<ul style="list-style-type: none"><li>• Make sure the Z-710 is on a level flat surface.</li></ul>
Difficulty feeding foods into the machine	<ul style="list-style-type: none"><li>• Materials may need to be cut into smaller lengthwise pieces.</li></ul>
Auger Housing does not fit onto the base	<ul style="list-style-type: none"><li>• Check to see if there are any foreign materials inside.</li></ul>
Juice leaks from the back of the Auger Housing	<ul style="list-style-type: none"><li>• The Auger Housing Retaining Ring may be loose, try reassembling</li><li>• You may have overloaded the unit; reduce the amount of food/produce being put in.</li></ul>



## WHEN YOU NEED SERVICE

In the unlikely event that you do need service on your Z-710 Manual Juice Extractor, or if it fails to function properly while within the warranty period (normal household operation only), please contact the nearest authorized Z-710 Service Center. PLEASE FOLLOW THE INSTRUCTIONS BELOW:

### SERVICE CENTER

Tribest Corp.

1143 N. Patt St., Anaheim, CA 92801, USA

TEL: 714-879-7150, TOLL FREE: 888-254-7336, FAX: 714-879-7140

EMAIL: [service@tribest.com](mailto:service@tribest.com) WEBSITE: [www.tribest.com](http://www.tribest.com)

- Call to obtain a Return Authorization Number to send your Z-Star Z-710 or part back to the service center. Explain the problem you are experiencing.
- Pack your Z-710 or part securely in its original shipping box. Make sure all necessary parts are enclosed.
- Fill out the Service Request Form and enclose it in the shipping box.
- Securely seal the shipping box.
- Address the box to the Service Center. Be sure to put your return address and the Return Authorization Number on the outside of the package.
- It is always wise to insure the package against possible damages or loss in transit. Ship prepaid.

## WARRANTY

We warrant to you, the end-user customer who has properly registered after purchasing the Z-Star® Z-710 Juice Extractor for a valuable consideration, that the plastic juicing parts and metal clamp parts will be free from defects in materials and workmanship for a period of 1 year from the date of purchase. All other parts, including but not limited to the Juice Container and the Plastic Plunger are not subject to any warranty. Warranty does not cover normal wear and tear.

In order for you to receive the benefits of this warranty, you are required to complete and mail the Warranty Registration Card, containing all the requested information, to us within ten (10) days following the purchase of your Z-710 Manual Juicer.

1. No warranty will be provided until after we have actually received the enclosed warranty registration card, containing all the requested information, within ten (10) days of the date of original purchase. The warranty is only good for the original purchaser for value. This warranty is non-transferable.
2. If the Z-710 exhibits defects while in normal household use, we will, upon our actual receipt of a written notice of such defects from you during the warranty period, either repair or replace, at our option, the Z-710 that has verifiable manufacturing defects. However, we have no such obligation to repair or replace until after you have, by insured mail and in protective packaging\*, delivered the Z-710 to the location of your Service Center as set forth on page 9. Replacement Z-710 may be either new or like new. Z-710 may contain re-manufactured or re-conditioned parts, which are equivalent to the new in performance or may have been subject to incidental use.
3. We do not warrant that the operation of the Z-710 will be uninterrupted or error free. In no event shall our liability exceed the retail value of the Z-710.
4. All warranty and repair services must be performed at a warranty service center, which is located within the country where the machine was originally purchased. However, in the event that: [i] the machine must be serviced at a service center, which is not located within the country where the machine was purchased; or [ii] there is no service center within the country where the machine is located and must be shipped to a service center in another country, then those service centers are responsible for the parts and service only, and any and all costs relating to the shipping, delivery and handling of the machine to and from those service center shall be the sole responsibility of the owner.

This warranty does not cover defects resulting from: [a] failure to operate the Z-710 in accordance with the instructions; [b] use of parts or supplies not provided or authorized by us; [c] negligent, improper or inadequate maintenance; [d] service performed or attempted by unauthorized service person; [e] damages, accidental or otherwise to the Z-710, which are not directly caused by us or the manufacturer; or [f] damages resulting from abuse, tampering, misuse, commercial use, or unauthorized modification of the Z-710.

WE MAKE NO OTHER EXPRESS OR IMPLIED WARRANTY OR CONDITION WHETHER WRITTEN OR ORAL TO THE EXTENT ALLOWED BY LOCAL LAW, ANY IMPLIED WARRANTY OF FITNESS FOR A PARTICULAR PURPOSE OR IMPLIED WARRANTY OR CONDITION OF MERCHANTABILITY IS LIMITED TO ONE (1) YEAR. In the event that such limitation or exclusion on the duration of an implied warranty is not allowed in the state or county wherein you reside, the above limitation or exclusion will not apply. This warranty gives you specific legal rights and protection, and you might also have other rights that vary from state to state, or country to country.

TO THE EXTENT ALLOWED BY LOCAL LAW, THE REMEDIES IN THIS WARRANTY STATEMENT ARE YOUR SOLE AND EXCLUSIVE REMEDIES. EXCEPT AS INDICATED ABOVE, IN NO EVENT WILL WE BE LIABLE FOR DIRECT, SPECIAL, INCIDENTAL, CONSEQUENTIAL (INCLUDING LOST PROFIT, OR OTHER DAMAGE, WHETHER BASED IN CONTRACT, TORT, OR OTHERWISE. Some states or counties may not allow the exclusion or limitation of incidental or consequential damages. If you reside in such a state or county, the above limitation or exclusion may not be applicable.

Do not send your Z-710 back to the Service Center without a Return Authorization No.

**\*Save Original Shipping Box**

## PRODUCT SPECIFICATION

ITEM	MANUAL VEGETABLE & FRUIT JUICER
MODEL	Z-710
SIZE	13.2in (335mm) x 12.6in (320mm) x 4.9in (125mm)
WEIGHT	6.8lbs (3.1kg)

© 2013 Tribest Corp.

No copies, transmission, or translation into other languages of this manual by any means without written permission of Tribest Corp. is allowed. All rights are reserved.

## NOTES

# NOTES

## NOTES



**Tribest Corporation**

P.O. Box 4089, Cerritos, CA 90703  
toll free: 888-254-7336 | fax: 714-879-7140  
[www.tribest.com](http://www.tribest.com) | [service@tribest.com](mailto:service@tribest.com)