

## Item # GEN3KIT30A

### INSTRUCTION MANUAL



Connect the parallel cables, making sure to first ground the cable. Be certain to match the same color wire into A and B. Start the GEN2000I first. When it is running you can start GEN1000I-PL.

This should give you a combined max output of 3,000 Surge Watts / 2,500 Running Watts.



**Item # GEN2000I**  
**2200 SURGE WATTS / 1800 RUNNING WATTS**  
**GASOLINE INVERTER**  
**PORTABLE GENERATOR**  
**INSTRUCTION MANUAL**



**READ ALL INSTRUCTIONS AND WARNINGS BEFORE USING THIS PRODUCT.**

This manual provides important information on proper operation & maintenance. Every effort has been made to ensure the accuracy of this manual. These instructions are not meant to cover every possible condition and situation that may occur. We reserve the right to change this product at any time without prior notice.

**IF THERE IS ANY QUESTION ABOUT A CONDITION BEING SAFE OR UNSAFE,  
DO NOT OPERATE THIS PRODUCT!**

**Visit our website for Frequently Asked Questions <http://sportsmanseriesbrand.com>**

**DO NOT RETURN THIS GENERATOR TO THE RETAILER!**

If you experience a problem, have questions or need parts for this product, call Customer Service at 1-866-460-9436, Monday-Friday, 8 AM - 4 PM Central Time. A copy of the sales receipt is required.

**FOR CONSUMER USE ONLY – NOT FOR PROFESSIONAL USE.**

**KEEP THIS MANUAL, SALES RECEIPT & APPLICABLE WARRANTY FOR FUTURE REFERENCE.**

**CALIFORNIA PROPOSITION 65**

WARNING: This product, or the exhaust from this product, may contain chemicals including lead compounds which are known to the State of California to cause cancer and birth defects or other reproductive harm.

For more information, view OEHHA's Proposition 65 page: <https://www.p65warnings.ca.gov>



## **CARBON MONOXIDE**

Using a generator indoors **CAN KILL YOU IN MINUTES**

Generator exhaust contains carbon monoxide (CO). This is a poison you cannot see or smell. If you can smell the generator exhaust, you are breathing CO. But even if you cannot smell the exhaust, you could be breathing CO.

## **CALIFORNIA PROPOSITION 65**

WARNING: This product, or the exhaust from this product, may contain chemicals including lead compounds which are known to the State of California to cause cancer and birth defects or other reproductive harm.

For more information, view OEHHA's Proposition 65 page: <https://www.p65warnings.ca.gov>

## Model GEN2000I 2200 Surge Watts / 1800 Running Watts

This unit is a Gasoline Fuel powered Inverter generator.

### FEATURES:

- 2200 Surge Output / 1800 Running Watts
- 120V Operation
- 3.0 HP Engine, 4 Stroke , 4650 RPM
- Displacement (CC): 79.7
- Low Oil Shut Off
- UL Listed Electrical Components
- Engine Shut Off Switch
- Power Outlets
- Spark Plug Model NGK CR7HSA
- 1-12V DC Outlet
- 2-120V Outlets
- Parallel Port Outlet Capability
- 1 Gallon Max Capacity Gasoline Fuel Tank
- Complies with EPA emissions & CARB
- Decibel Rating < 60 db 0% load measured at 23 feet
- Run time =7 hrs @ 50% load Gasoline
- Fuel Type: Unleaded Gasoline Only with Octane rating 87 or higher
- If you are using a generator above sea level, the generator may not function properly because of air flow getting through the mixer.
- High Altitude Use: This generator is not recommended for high altitude use above 3,000 feet.



### 2 YEAR LIMITED EMISSION-RELATED WARRANTY

THIS ENGINE MEETS U.S. EPA EMISSION STANDARDS UNDER 40 CFR 1054.625 .The emission-related limited warranty is valid for two (2) years. Keep the purchase receipt and mail in the product registration card for proof of purchase. Buffalo Corp limits emission-related warranty repairs to authorized service centers for owners located within 100 miles of an authorized service center. For owners located more than 100 miles from an authorized service center, Buffalo Corp will, in its sole discretion, either pay for shipping costs to and from an authorized service center, provide for a service technician to come to the owner to make the warranty repair, or pay for the repair to be made at a local non-authorized service center. The provisions of this paragraph apply only for the contiguous states, excluding the states with high-altitude areas identified in 40 CFR part 1068, Appendix III.

To exercise this warranty, DO NOT RETURN TO RETAILER. Instead, call Customer Service toll free at 1-866-460-9436 (email address [info@buffalotools.com](mailto:info@buffalotools.com)) and you will be instructed on where to take the engine for warranty service. Take the generator and proof of purchase (your receipt) to the repair facility recommended by the Customer Service Representative. The warranty does not extend to generators damaged or affected by fuel contamination, accidents, neglect, misuse, unauthorized alterations, use in an application for which the product was not designed and any other modifications or abuse.

### 1 YEAR LIMITED WARRANTY (30 Day Limited Warranty for Commercial and Rental Purpose)

Generators are warranted to be free from defects in materials and workmanship for a period of 1 YEAR from date of original purchase. Buffalo Corp. is not liable for any indirect, incidental or consequential damages from the sale or use of this product. Any implied warranties are limited to 1 YEAR as stated, or as otherwise stated, in this written limited warranty. Some states do not allow the exclusion or limitation of incidental or consequential damages. Some states do not allow limitation on the length of an implied warranty. Buffalo Corp will repair or replace, at its discretion, any part that is proven to be defective in materials or workmanship under normal use during the 1 YEAR warranty period. Warranty repairs or replacements will be made without charge for parts or labor. Parts replaced during warranty repairs will be considered as part of the original product and will have the same warranty period as the original product. This warranty gives you specific legal rights, and you may have other rights that vary state to state

# TABLE OF CONTENTS

|   |    |
|---|----|
| RECOGNIZE SAFETY SYMBOLS, WORDS AND LABELS..... | 5  |
| PACKAGE CONTENTS                                |    |
| PACKAGE CONTENTS .....                          | 10 |
| COMPONENTS .....                                | 11 |
| PREPARING THE GENERATOR FOR USE .....           | 11 |
| Using This Generator For The First Time.....    | 12 |
| Step 1 – Add Oil .....                          | 12 |
| Step 2 – Connect Fuel.....                      | 13 |
| Step 3 – Ground The Generator.....              | 14 |
| Subsequent Use Of This Generator.....           | 14 |
| Step 1 – Verify Oil Level .....                 | 14 |
| Step 3 – Ground The Generator.....              | 15 |
| STARTING THE GENERATOR.....                     | 15 |
| USING THE GENERATOR.....                        | 16 |
| AC Usage.....                                   | 16 |
| AC Parallel Usage.....                          | 18 |
| DC Usage.....                                   | 19 |
| STOPPING THE GENERATOR.....                     | 19 |
| MAINTENANCE/CARE .....                          | 20 |
| Recommended Maintenance Schedule .....          | 20 |
| Cleaning The Generator.....                     | 20 |
| Checking The Oil Level .....                    | 20 |
| Changing/Adding Oil .....                       | 21 |
| Air Filter Maintenance .....                    | 22 |
| Spark Plug Maintenance .....                    | 22 |
| Spark Arrestor .....                            | 23 |
| Changing Fuel Line .....                        | 23 |
| Fuel Tank Usage & Maintenance.....              | 23 |
| STORAGE/TRANSPORT PROCEDURES .....              | 23 |
| TROUBLESHOOTING .....                           | 24 |
| SPECIFICATIONS .....                            | 25 |
| PARTS DIAGRAM .....                             | 26 |
| WIRING DIAGRAM .....                            | 30 |
| EMISSIONS CONTROL SYSTEM WARRANTY .....         | 31 |

# RECOGNIZE SAFETY SYMBOLS, WORDS AND LABELS

## What You Need to Know About Safety Instructions

Warning and Important Safety Instructions appearing in this manual are not meant to cover all possible conditions and situations that may occur. Common sense, caution and care must be exercised when operating or cleaning tools and equipment.

Always contact your dealer, distributor, service agent or manufacturer about problems or conditions you do not understand.



This is the safety alert symbol. It is used to alert you to potential personal injury hazards. Obey all safety messages that follow this symbol to avoid possible injury or death.



DANGER indicates an imminently hazardous situation which, if not avoided, will result in death or serious injury.



WARNING indicates a potentially hazardous situation which, if not avoided, could result in death or serious injury.



CAUTION indicates a potentially hazardous situation which, if not avoided, may result in minor or moderate injury.



CAUTION used without the safety alert symbol indicates a potentially hazardous situation which, if not avoided, may result in property damage.

### High Altitude Use:

This generator is not recommended for high altitude use above 3,000 feet.

### Legal Requirements:

Federal and/or State Occupational Safety and Health Administration (OSHA) regulations, local codes, and/or ordinances may apply to the intended use of this generator. Consult a qualified electrician, electrical inspector, and/or the local agency having jurisdiction. Some areas require generators to be registered with local utility companies. Additional regulations may apply if this generator will be used at a construction site.

## IMPORTANT SAFETY INSTRUCTIONS

# STOP!

Before using this generator and if you have any questions regarding the hazard and safety notices listed in this manual and/or on this generator, call 1-866-460-9436, Monday - Friday, 8 AM - 4 PM Central Time.

### **DANGER**

**Carbon Monoxide Gas:** When in operation, the exhaust from this generator contains poisonous carbon monoxide gas. Carbon monoxide gas is both odorless and colorless AND may be present even if you do not see or smell gas. Breathing this poison gas can lead to headaches, dizziness, drowsiness, loss of consciousness and eventually death.

- Use this generator ONLY outdoors in non-confined areas.
- Keep at least several feet of clearance on all sides to allow proper ventilation for this generator.

### **DANGER**

**Powerful Voltage:** This generator produces powerful voltage, which can result in electrocution.

- ALWAYS ground this generator before using it. (See "Ground the Generator" section in this manual).
- Only electrical devices should be plugged into this generator, either directly or with an extension cord. NEVER connect a building electrical system to this generator without a qualified electrician. *Doing so voids your warranty.* Such connections must isolate generator power from utility power and comply with local electrical laws and codes. Failure to comply can create a back feed into utility lines creating an electrocution hazard, which may result in serious injury or death to utility workers. Such a back feed may cause this generator to explode, burn and create fires when utility power is restored.
- Do not use this generator in wet conditions (rain, snow, active sprinkler system, wet hands, etc.). Always keep this generator dry and operate it with dry hands.
- Do not touch bare wires or outlets (receptacles).
- Do not allow children or non-qualified persons to operate this generator.

### **DANGER**

**High Temperatures:** This generator produces heat when in operation. Temperatures near the exhaust can exceed 150 Degrees Fahrenheit (65 Degrees Celsius).

- Do not touch hot surfaces. Observe all warning placards on this generator denoting hot surfaces.
- Allow this generator to cool for several minutes after use before touching the engine, muffler or other areas that are hot during operation and before storing indoors.
- Hot exhaust may ignite some materials. Keep flammable materials away from this generator.
- Keep at least several feet of clearance on all sides of this generator during operation. Do not enclose this generator in any structure.

### **WARNING**

**Usage:** Avoid the use of extension cords if possible. If you choose to use them, be sure they are sized adequately to handle the flow of electricity. An undersized cord can overheat, short out and cause a fire.

**⚠ CAUTION**

**Usage:** Misuse of this generator can damage it or shorten its life.

- Use this generator only for its intended purpose.
- Operate this generator only on a dry, level surface.
- Allow this generator to run for several minutes before connecting any electrical devices.
- Promptly turn off any malfunctioning devices and disconnect them.
- Do not operate an excessive number of electrical devices in excess of the wattage capacity of this generator.
- Do not turn on electrical devices until *after* they are connected to this generator.
- Turn off all connected electrical devices before stopping this generator.

**⚠ WARNING**

**Usage:** Consult a physician(s) before using this generator if using a pacemaker. Electromagnetic fields in close proximity to a heart pacemaker could cause a pacemaker to malfunction or fail. Caution is necessary when near the engine's recoil starter.

**⚠ CAUTION**

**Usage:** Prolonged exposure to high noise levels can be hazardous to hearing. Always wear ANSI-approved hearing protection when operating or working around the generator when it is running.



## **⚠ WARNING**

THIS GENERATOR PRODUCES HEAT WHEN RUNNING. TEMPERATURES NEAR EXHAUST CAN EXCEED 150°F. (65° C) DO NOT TOUCH HOT SURFACES. PAY ATTENTION TO WARNING LABELS ON THE GENERATOR DENOTING HOT PARTS OF THE MACHINE. ALLOW GENERATOR TO COOL AFTER USE BEFORE TOUCHING ENGINE OR AREAS WHICH HEAT DURING USE.

## **⚠ WARNING**

This product, or exhaust from the generator, can expose you to chemicals including lead compounds which are known to the State of California to cause cancer. For more information, visit [www.P65Warnings.ca.gov](http://www.P65Warnings.ca.gov)

## **⚠ WARNING**

EXHAUST CONTAINS POISONOUS CARBON MONOXIDE GAS THAT CAN BUILD UP TO DANGEROUS LEVELS IN CLOSED AREAS. BREATHING CARBON MONOXIDE CAN CAUSE UNCONSCIOUSNESS OR DEATH. Never run the generator in a closed or even partly closed area where people may be present.

## **⚠ WARNING**

THE GENERATOR IS A POTENTIAL SOURCE OF ELECTRICAL SHOCK IF NOT KEPT DRY. Do not expose the generator to moisture, rain or snow. Do not operate the generator with wet hands. READ OWNER'S MANUAL CAREFULLY BEFORE OPERATION.

## **⚠ DANGER**

IMPROPER CONNECTIONS TO A BUILDING CAN ALLOW ELECTRICAL CURRENT TO BACKFEED INTO UTILITY LINES, CREATING AN ELECTROCUTION HAZARD. Connections to a building must isolate generator power from utility power and comply with all applicable laws and electrical codes.

## **⚠ WARNING**

GASOLINE IS HIGHLY FLAMMABLE AND EXPLOSIVE. YOU COULD BE BURNED OR SERIOUSLY INJURED IF THE GASOLINE IS IGNITED. Before refueling, stop the engine and keep heat, sparks and flame away. Handle fuel only outdoors. Do not fill the fuel tank above the upper limit line. Wipe up spills immediately.

In addition to the previously described safety information, familiarize yourself with all safety and hazard notices on this generator.

**⚠ DANGER POISONOUS GAS**

Generator exhaust contains toxic carbon monoxide gas. Breathing exhaust can cause loss of consciousness and shortness of breath. NEVER operate generator in poorly ventilated areas.

**⚠ WARNING**

Risk of electric shock. Do not remove cover. No user serviceable parts inside. Refer servicing to qualified service personnel.

**⚠ WARNING! RISK OF ELECTRIC SHOCK**

**This generator produces high voltage.**  
 Always ground properly before use.  
 Do not connect to any building electrical system.  
 Never use in rainy or wet conditions.  
 Never touch bare wires or receptacles.  
 Never allow children or non-qualified person to operate.



USE THIS GENERATOR ONLY OUTDOORS IN NON-CONFINED AREAS. DO NOT SECURE THE GENERATOR WITH A CHAIN OR ROPE, AS THIS WILL MAKE IT DIFFICULT TO MOVE IN AN EMERGENCY.

**⚠ DANGER**

Using a generator indoors CAN KILL YOU IN MINUTES. Generator exhaust contains carbon monoxide. This is a poison you cannot see or smell.

|   |  |
|---|--|
|   |  |
| <b>NEVER</b> use inside a home or garage, EVEN IF doors and windows are open. | Only use <b>OUTSIDE</b> and far away from windows, doors, and vents. |

**Avoid other generator hazards. READ MANUAL BEFORE USE.**

**⚠ CAUTION! HOT EXHAUST**

**⚠ DO NOT TOUCH**



**⚠ CAUTION! HIGH TEMPERATURE DO NOT TOUCH**



## PACKAGE CONTENTS

The following items are supplied with this Model GEN2000I Portable Gasoline Inverter Generator. Verify that all items are included.

# STOP!

If there are missing items, call 1-866-460-9436, Monday - Friday, 8 AM - 4 PM Central Time for customer service. **DO NOT RETURN THIS GENERATOR TO THE RETAILER.**

| Item List:   |  |
|--|--|
|   | Set of 2 DC connector wires for charging 12 Volt automotive-type batteries |
|   | Spark plug wrench  |
|  | Funnel for adding Oil  |

|   |                       |
|---|-----------------------|
|  | T Type Wrench         |
|  | Sockets               |
|  | Crosshead screwdriver |

## GENERATOR COMPONENTS

Observe the locations and functions of the various components and controls of this generator.

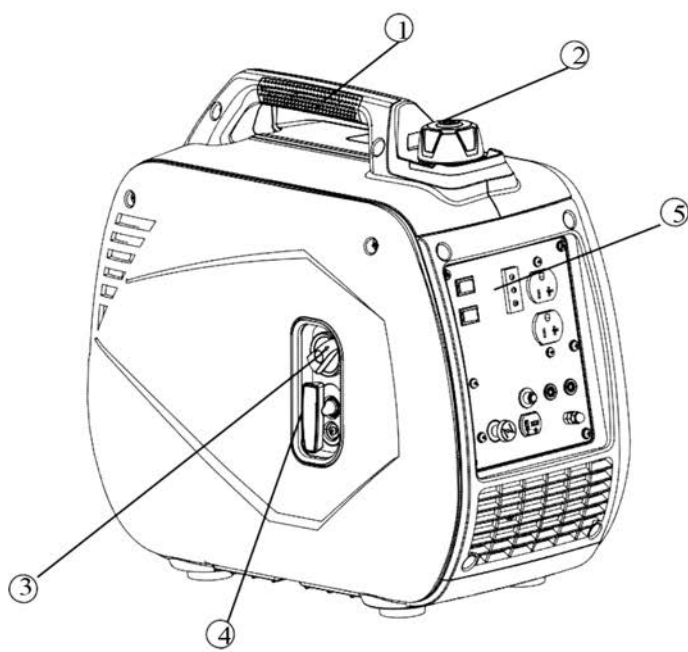

1. Carrying handle
2. Fuel Cap
3. Fuel Switch
4. Recoil Starter Grip
5. Control Panel

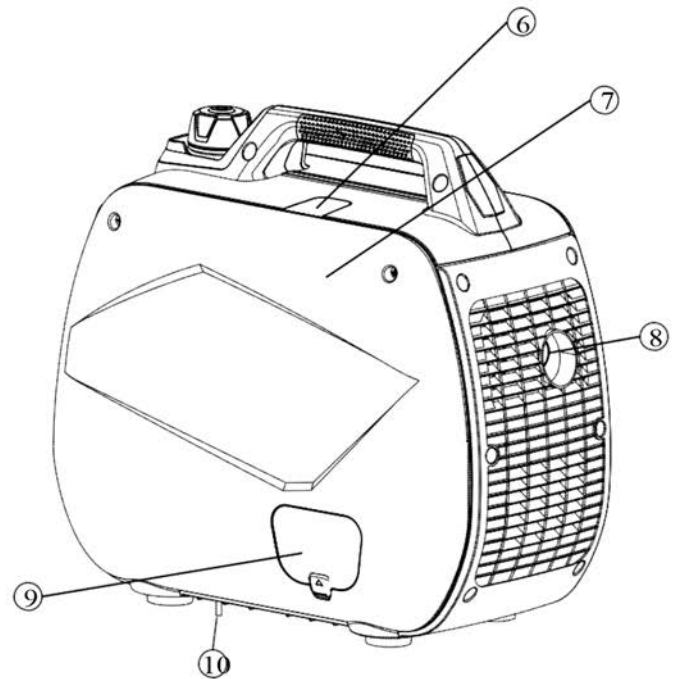

6. Spark Plug Cap
7. Removable Service Panel
8. Muffler
9. Oil Check Access
10. Fuel drain pipe

To prevent electrical shock from faulty appliances, the generator should be grounded. Connect a length of heavy wire between the ground terminal and the ground source.

Consult with a qualified electrician to ensure compliance with local electrical codes.

### ATTENTION:

The Air-fuel Mixer is not adjustable. Tampering with the governor can damage your generator and electrical devices, and will void your warranty.

# PREPARING THE GENERATOR FOR USE

## Using this Generator for the First-Time

# STOP!

# CAUTION

The following section describes the required steps for preparing this generator for the first use. Failure to correctly perform these steps can damage this generator and/or shorten its life. If still unsure about how to perform any of these steps after reading this section, call 1-866-460-9436 Monday - Friday, 8 AM - 4 PM Central Time for customer service.

If this generator is being used for the first time, the following few steps are required to prepare it for operation:

### Step 1 - Add Oil

This generator requires engine oil to function. Engine oil is a major factor affecting engine performance and service life. When new from the package, this generator contains no oil in the engine crankcase. Add the correct quantity of oil before operating this generator for the first time. When replenishing oil for subsequent use of this generator, always determine that this generator has the correct quantity of oil.

|  |                                     |
|--|-------------------------------------|
| <b>Model GEN2000i Oil Capacity</b>         | 13.5 ounces                         |
| <b>Model GEN2000i Oil Type Recommended</b> | High Detergent Motor Oil, SAE10W-30 |

To add oil:

1. Confirm that this generator is on a level surface.
2. Unscrew the oil filler/dipstick cap from the engine as illustrated in Figure 1.
3. Using a funnel, add high detergent motor oil to fill the engine crankcase to the correct quantity. SAE10W-30 oil is recommended for general, all-temperature use. **When the engine crankcase is full, the oil level should reach all the way up to the threads** as illustrated in Figure 2.
4. Replace the oil filler/dipstick cap.

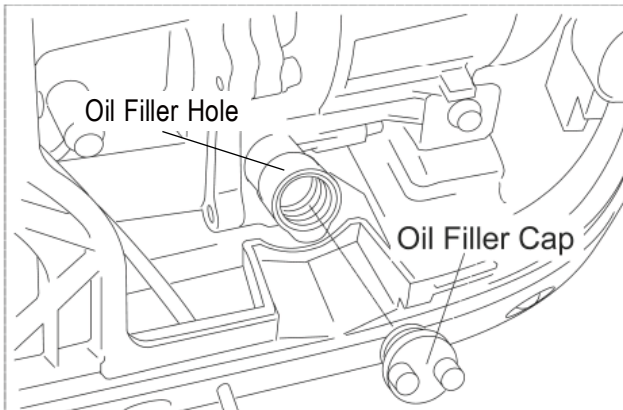

Figure 1 - Unscrew the Oil Cap



Figure 2 - Add Oil To TOP Of Threads

## Step 2 – Connect Fuel

Add Unleaded gasoline only with an octane rating of 87 or higher.  
Maximum Capacity: 1.0 Gallons

### Pre-Operation Check List

Step 1 Check that the gas supply source is in good condition. Check that the gas inlet connection is tightly fixed and not leaking.

Step 2 CHOKE VALVE GRIP is at CHOKE (CLOSE) position. The generator may be hard to start if CHOKE VALVE GRIP is at RUN (OPEN) position.

Step 3 Check if engine oil is full.

Step 4 Make sure GROUND TERMINAL is properly grounded.

Step 5 AC OUTPUT no load connected.

Disconnect all electrical loads from the generator set before starting the engine. The generator may be hard to start if a load is connected.

Step 6 DC OUTPUT no load connected.

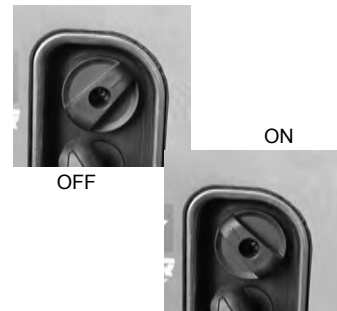
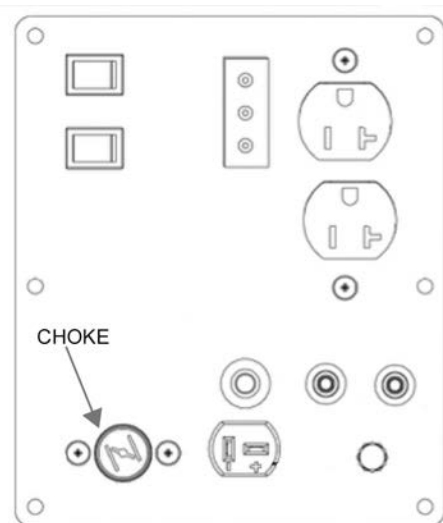

### Step 3 - Ground the Generator

#### **WARNING**

Failure to properly ground this generator can result in electrocution.

Ground this generator by tightening the grounding nut against a grounding wire as illustrated in Figure 3. A No. 12 AWG (American Wire Gauge) stranded copper wire is generally an acceptable grounding wire. The other end of this grounding wire should be connected to a copper or brass grounding rod that is driven into the earth.

Grounding codes can vary by location. Contact a local electrician for information on grounding regulations for your area.

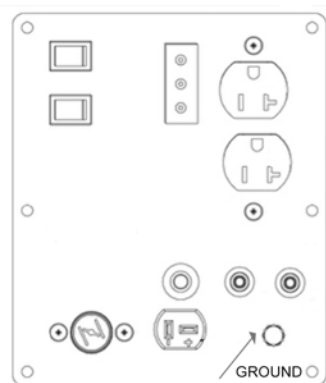

Figure 3 - Attaching the Grounding Wire to this Generator

### Subsequent Use of this Generator

For subsequent uses of this generator after the first use, certain steps still must be completed to prepare it for operation.

**IMPORTANT:** Be familiar with the procedures described in the previous section titled “Using the Generator for the First Time” of this manual. If not, review this section now.

### Step 1 - Verify Oil Level

Even though this generator is equipped with an automatic shutoff to protect it from damage due to low oil, it is important to check the oil level in the engine crankcase before each use to ensure that there is sufficient quantity.

1. Verify that this generator is on a level surface.
2. Unscrew the oil filler/dipstick cap from the engine.
3. With a dry cloth, wipe the oil off of the dipstick that is located on the inside of the cap.
4. Fully insert the dipstick without screwing the filler/dipstick cap and then remove again. There should be oil on the dipstick. If there is no oil on the dipstick, or oil is visible only at the very end of the dipstick, add oil until the engine crankcase is filled. (See “Changing/Adding Oil” in the “Maintenance/Care” section of this manual).
5. Confirm that the oil filler/dipstick cap is properly screwed in place when finished verifying the oil level.

|  |                                     |
|--|-------------------------------------|
| <b>Model GEN2000I Oil Capacity</b>         | 13.5 ounces                         |
| <b>Model GEN2000I Oil Type Recommended</b> | High Detergent Motor Oil, SAE10W-30 |

### Step 3 - Ground the Generator

#### **WARNING**

Failure to properly ground this generator can result in electrocution.

Ground this generator by tightening the grounding nut against a grounding wire as previously illustrated in Figure 3. A generally acceptable grounding wire is a No. 12 AWG (American Wire Gauge) stranded copper wire. The other end of this grounding wire should be connected to a copper or brass grounding rod that is driven into the earth. Grounding codes can vary by location. Contact a local electrician for information on grounding regulations for your area.

## STARTING THE GENERATOR

# STOP!

Before starting this generator, confirm that all the steps in the section titled, "Preparing the Generator for Use," of this manual have been correctly completed. If unsure about how to perform any of these steps, call 1-866-460-9436, Monday - Friday, 8 AM - 4 PM Central Time for customer service.

#### **CAUTION**

Disconnect all electrical loads from this generator before attempting to start.

- Step 1 Make sure unleaded gasoline fuel has been added to the tank.
- Step 2 Turn ENGINE SWITCH at ON position.
- Step 3 Move Choke Lever to CHOKE position.
- Step 4 For recoil start: Pull the STARTER GRIP slowly until resistance is felt and then pull rapidly. After the engine started, return the STARTER GRIP gently to prevent damage to the starter or housing. DO NOT allow the starter grip to snap back. Return it slowly by hand.
- Step 5 Turn the CHOKE LEVER to RUN position.

### Choke Rod

The choke is used to provide an enriched fuel mixture when starting a cold engine. It can be opened and closed by operating the choke rod manually. Pull the rod out toward CLOSED to enrich the mixture for cold starting



## USING THE GENERATOR

After the engine has been running for several minutes, electrical devices may be connected to this generator.

### AC Usage

Electrical devices running on AC current may be connected according to their wattage requirements. The rated (running) and surge wattage:

|   |      |
|---|------|
| <b>Model GEN2000I Rated (Running) Wattage</b> | 1800 |
| <b>Model GEN2000I Surge Wattage</b>           | 2200 |

The *rated (running) wattage* corresponds to the maximum wattage a generator can output on a continuous basis.

The *surge wattage* corresponds to the maximum amount of power a generator can output for a short time. Many electrical devices, such as a refrigerator, require short bursts of extra power for starting and stopping fan motors, etc., in addition to their listed rated wattage. Motorized devices typically require more than their rated wattage for startup. The surge wattage ability of a generator allows for this extra power requirement.

The total running wattage requirement of the electrical devices connected to a generator should not exceed the rated wattage of the generator itself. To calculate the total wattage requirement of the electrical devices to be connected, look up the rated (running) wattage of each device and add these numbers together to find the total wattage that all of the devices together will draw from the generator. If the total wattage of the selected devices exceeds the rated wattage of the generator, DO NOT connect all of the devices. Select a combination of the electrical devices that will have a total wattage less than or equal to the rated wattage for the generator, i.e., no more than 1800 watts for this generator.

### **⚠ CAUTION**

This generator can run at its surge wattage capacity for only a short time. Connect electrical devices requiring a rated (running) wattage equal to or less than the rated wattage of this generator. Never connect devices requiring a rated wattage equal to the surge wattage of a generator.

A device's rated (running) wattage should be listed somewhere on the device itself and/or in its manual. If the wattage specification for a device is not available, the wattage can be calculated by multiplying the Voltage requirement (120 or 240) by the Amperage drawn.

Watts = Volts x Amperes

Or, the wattage required by a device can be estimated by using the following chart (see Figure 7). The chart provides only estimates and it is better to know the exact wattage of each electrical device to be powered by this generator.

| Electrical Device                  | Rated (Running) Watts | Additional Surge Watts |
|------------------------------------|-----------------------|------------------------|
| air compressor (1 HP)              | 1500                  | 3000                   |
| air compressor (1 - 1/2 HP)        | 2500                  | 2500                   |
| airless sprayer (1/3 HP)           | 600                   | 1200                   |
| box fan                            | 300                   | 600                    |
| clock radio AM/FM                  | 300                   | 0                      |
| coffee maker                       | 1500                  | 0                      |
| computer w/17 inch monitor         | 800                   | 0                      |
| deep freezer                       | 500                   | 500                    |
| electric drill (1/2 HP)            | 1000                  | 1000                   |
| DVD/CD player or VCR               | 100                   | 0                      |
| furnace fan blower (1/2 HP)        | 800                   | 1300                   |
| garage door opener (1/2 HP)        | 480                   | 520                    |
| hot plate                          | 2500                  | 0                      |
| light bulb (75 watt)               | 75                    | 0                      |
| microwave oven (1000 watt)         | 1000                  | 0                      |
| quartz halogen work light          | 1000                  | 0                      |
| refrigerator/freezer (18 Cu. Ft.)  | 800                   | 1600                   |
| saw - circular (7 1/4 inch)        | 1500                  | 1500                   |
| saw - miter (10 inch)              | 1800                  | 1800                   |
| saw - reciprocating                | 960                   | 1040                   |
| security system                    | 180                   | 0                      |
| electric stove - single element    | 1500                  | 0                      |
| sump pump                          | 800                   | 1200                   |
| television (27 inch color)         | 500                   | 0                      |
| electric water heater (40 gallon)  | 4000                  | 0                      |
| window air conditioner (10000 BTU) | 1200                  | 1800                   |
| window fan                         | 300                   | 600                    |

**Figure 7 - Estimated wattage requirements for common electrical devices.**

Connect electrical devices to this generator according to the following procedure:

1. Allow the engine to run for several minutes after it has been started.
2. Confirm that the electrical device is switched off prior to plugging it into this generator.

**CAUTION**

Connect only electrical devices that are in good working order. Faulty devices or power cords present the risk of electrical shock. Immediately turn off and disconnect any device that commences to operate abnormally, sluggish or abruptly stops. Determine if the problem was the device or the rated load capacity of this generator has been exceeded.

**NOTE:** While this generator is running, power is available from either the standard 120 Volt outlets or the 12 Volt DC outlet. Both 120 Volts and 12V can be simultaneously drawn from this generator.

3. Turn on the connected electrical devices beginning with the device with the highest rated wattage requirement and then each additional device with the next lower rated wattage requirement.

**CAUTION**

Do not connect 50Hz or 3-phase loads to this generator.

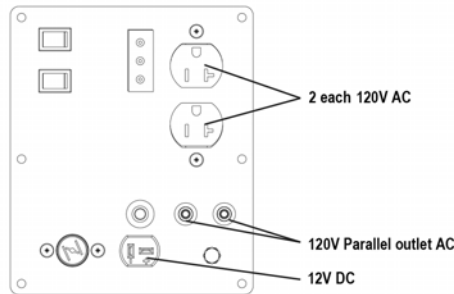

Figure 8 - Outlets available on this generator

**SOME NOTES ABOUT POWER CORDS**

Long or thin cords can require more wattage from a generator to power an electrical device. Figure 9 shows the recommended cords according to the power requirement of the electrical device. When using cords that exceed these specifications, allow for the electrical device to have a slightly higher rated wattage requirement.

| Device Requirements |              |              | Max. Cord Length (ft) by Wire Gauge |          |          |          |          |
|---------------------|--------------|--------------|-------------------------------------|----------|----------|----------|----------|
| Amps                | Watts (120V) | Watts (240V) | #8 wire                             | #10 wire | #12 wire | #14 wire | #16 wire |
| 2.5                 | 300          | 600          | NR                                  | 1000     | 600      | 375      | 250      |
| 5                   | 600          | 1200         | NR                                  | 500      | 300      | 200      | 125      |
| 7.5                 | 900          | 1800         | NR                                  | 350      | 200      | 125      | 100      |
| 10                  | 1200         | 2400         | NR                                  | 250      | 150      | 100      | 50       |
| 15                  | 1800         | 3600         | NR                                  | 150      | 100      | 65       | NR       |
| 20                  | 2400         | 4800         | 175                                 | 125      | 75       | 50       | NR       |
| 25                  | 3000         | 6000         | 150                                 | 100      | 60       | NR       | NR       |
| 30                  | 3600         | 7200         | 125                                 | 65       | NR       | NR       | NR       |
| 40                  | 4800         | 9600         | 90                                  | NR       | NR       | NR       | NR       |

NR = Not Recommended.

Figure 9 - Maximum Extension Cord Lengths by Power Requirement

**ECONOMY SWITCH**

The Economy Switch automatically reduces engine speed when loads are turned off or disconnected. When appliances are turned on or reconnected, the engine returns to the proper speed to power the electrical load. If high electrical loads are connected simultaneously, turn the Economy switch to the OFF position to reduce voltage changes.

**ECONOMY ON:** Recommended to minimize fuel consumption and further reduce noise levels when less than a full load is applied to the generator.

**ECONOMY OFF:** The Economy function will not operate. When using the DC output, turn the Economy Switch to the OFF position. Make sure the Economy Switch is in the OFF position before starting. Turn the Economy Switch to the ON position after the engine has warmed up for 2 or 3 minutes

## AC PARALLEL TERMINALS

The parallel port terminals are used with a parallel kit (sold separately). It will allow two generators to be linked to increase output. The black and white wire connections are non-polarized and can be inserted into either the left or right ports.

NOTE: Do not disconnect cables while the generator is running. The generator or the load may be damaged.

NOTE: Only connect two identical Inverter Generators together using a Parallel Kit.

### **⚠ WARNING**

Do not pair more than 2 generators.

Only use the BUFFALO parallel output cable for parallel operation (sold separately).

### **⚠ CAUTION**

You can use the outlets on the control panel of the generator while operating in parallel. Do not exceed combined load on all outlets 26 amps running or 33 amps surge.

### **⚠ WARNING**

If parallel cables are not properly connected to the generators, either or both generators can be damaged and could explode.

### **⚠ CAUTION**

DO NOT connect or disconnect the parallel connection cable from the control panel while the generators are running. Turn off both generators before disconnecting parallel cables.

Before connecting an appliance to a generator, make sure that the appliance is in good working order and that its electrical rating does not exceed that of the outlet. Most appliances require more than their electrical rating for startup.

1. Have both generators ready to operate.
2. Plug in BOTH parallel cables FIRST. If you attach black wire on left A and white wire on right B, duplicate the same position on the opposite generator.
3. Attach both ground connections on both control panels.
4. Power up each generator, with the Economy Switch in off position.
5. After running a few minutes, plug in appliances into RV cable or outlet on control panel. Make sure appliances are off.
6. Gradually turn on each appliance after making sure both generators are in normal running (the output indicator LED (green) flashes).

**Note:** The required power of the electrical appliance connected to the parallel outlet cannot exceed the rated output of paralleled generators. See specifications page in owner's manual.

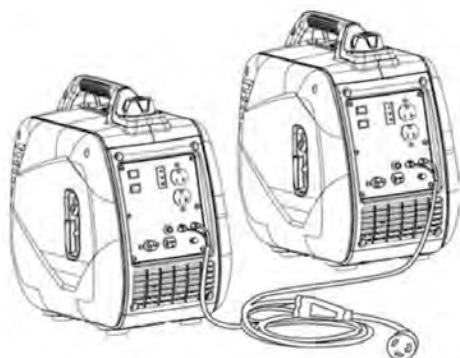

### **Turning Off Generators while in Parallel Function**

1. Disconnect or turn off item plugged into parallel receptacle.
2. Turn off both generators.
3. Carefully disconnect the parallel cables from both generators

## DC Usage

### CAUTION

The DC outlet is only for recharging 12 Volt automotive-type batteries. Do not connect any other device to this outlet.

### CAUTION

Use this generator only for recharging 12 Volt batteries. NEVER attempt to jumpstart a car with this generator.

### DANGER

Failing to use the correct procedure can cause a battery to explode, seriously injuring anyone nearby. Keep heat, sparks, flame and smoking materials away from the battery.

To connect 12 Volt batteries to the DC outlet:

1. Connect the red charging wire to the positive terminal of the battery and the black charging wire to the negative terminal of the battery.
2. Connect the plug end of the wire to the 12V DC outlet on this generator.
3. Start this generator.
4. When disconnecting, always disconnect the wires from this generator first to avoid a spark.

### DANGER

**Storage batteries emit highly explosive hydrogen gas when charged.**

**Batteries also contain acid, which can cause severe chemical burns.**

- Do not allow open flames or cigarettes nearby for several minutes after charging a battery.
- Always wear protective goggles and rubber gloves when charging a battery.
  - If battery acid gets on the skin, flush with water.
  - If battery acid gets in the eyes, flush with water and immediately call a physician.
  - If battery acid is swallowed, drink large quantities of milk and immediately call a physician.

## STOPPING THE GENERATOR

To stop this generator:

1. Turn off all connected electrical devices and then unplug them.
2. Allow this generator to run for several more minutes with no electrical devices connected to help stabilize the temperature of this generator.
3. Turn off the engine switch.

### WARNING

Allow this generator to cool down before touching areas that become hot during operation.

## MAINTENANCE/CARE

Proper routine maintenance of this generator is essential for safe, economical, and trouble-free operation. It will help prolong the life of this generator as well as help reduce air pollution. Perform maintenance checks and procedures according to the schedule in Figure 10.

# STOP!

If you have questions about maintenance procedures described in this manual, call 1-866-460-9436, Monday - Friday, 8 AM - 4 PM Central Time.

### **CAUTION**

Never perform maintenance procedures while this generator is running. Allow this generator to cool before commencing any maintenance procedures. Keep heat, sparks and flame away.

### **WARNING**

Improper maintenance and/or failure to correct any problems prior to operating this generator can cause a malfunction which could cause death or serious injury. Always follow the inspection and maintenance recommendations and schedules in this manual.

## Recommended Maintenance Schedule

|                   |              | Each Use | Every Month or Each 20 Hrs | Every 3 Months or Each 50 Hrs | Every 6 Months or Each 100 Hrs | Every Year or Each 300 Hrs |
|-------------------|--------------|----------|----------------------------|-------------------------------|--------------------------------|----------------------------|
| Engine Oil        | Check Level  | X        |                            |                               |                                |                            |
|                   | Replace      |          | X (First Use)              |                               | X                              |                            |
| Air Filter        | Check        |          |                            |                               |                                |                            |
|                   | Clean        |          |                            | X                             |                                | X                          |
| Fuel Filler       | Clean        |          |                            |                               | X                              |                            |
| Spark Plug        | Check/Clean  |          |                            | X                             |                                |                            |
|                   | Clean        |          |                            |                               |                                | X                          |
| Spark Arrestor    | Clean        |          |                            |                               | X                              |                            |
| Valve<br>Cleanace | Check/adjust |          |                            |                               |                                | X                          |

Figure 10 - Recommended maintenance schedule

## Cleaning the Generator

Always try to use this generator in a cool dry place. If this generator becomes dirty, the exterior can be cleaned with a damp cloth, soft brush, vacuum and/or pressurized air.

Never clean this generator with a bucket of water and/or a hose as water can get inside and cause a short circuit or corrosion.

Never use gasoline to clean parts of this generator.

## Checking the Oil Level

Even though this generator is equipped with an automatic shutoff to protect it from damage due to low oil, it is important to check the oil level in the engine crankcase before each use to ensure that there is a sufficient quantity.

To check the oil level:

1. Verify that this generator is shut down and on a level surface.
2. Unscrew the oil filler/dipstick cap from the engine as illustrated in Figure 11.
3. With a dry cloth, wipe the oil off of the dipstick that is located on the inside of the cap.
4. Insert the dipstick as if replacing the cap and then remove again. There should be oil on the dipstick. If there is no oil on the dipstick, or oil is visible only at the very end of the dipstick, add oil until the engine crankcase is filled (see "Changing/Adding Oil" in this section of this manual).
5. Confirm that the oil filler/dipstick cap is properly in place when finished verifying the oil level.

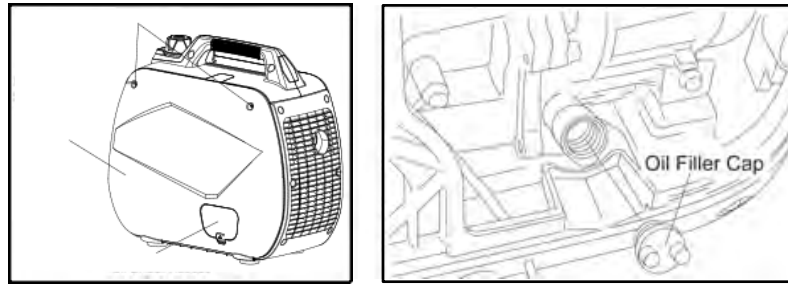

Figure 11 - Checking the Oil

## Changing/Adding Oil

The oil level in this generator should be checked before each use. When the oil level is low, add oil until the level is sufficient to operate this generator.

To drain the oil from this generator:

The oil should be changed after the first 20 hours of operation. The oil should then be changed every 6 months, or for every 100 hours of use time, or when it has become contaminated with water and/or dirt.

Drain the oil while the engine is still warm to assure rapid and complete draining.

1. Loosen the cover screw and remove the maintenance cover. (Fig 11A)
2. Remove the oil filler cap (Fig 11B).
3. Drain dirty oil into a container.
4. Refill with the recommended oil, and check the oil level.
5. Reinstall the maintenance cover and tighten the cover screw securely.
6. Engine oil capacity: 13.5 ounces
7. Wash your hands with soap and water after handling used oil.

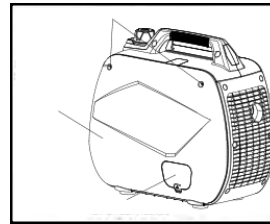

(Fig 11A)

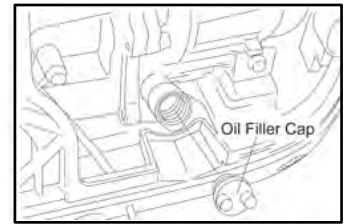

(Fig 11B)

**NOTE: Never dispose of used motor oil in the trash, down a drain or on the ground. Put oil in a sealed container and contact your local recycling center or auto garage to arrange oil disposal.**

To add oil to the engine crankcase:

1. Confirm that this generator is on a level surface.
2. Unscrew the oil filler/dipstick cap from the engine as illustrated in Figure 11 above.
3. Using a funnel, add high detergent motor oil to fill the engine crankcase to the correct quantity. SAE10W-30 oil is recommended for general use.

When the engine crankcase is full, the oil level should reach the lower lip of the oil filling opening as shown in Figure 12.

|  |                                     |
|--|-------------------------------------|
| <b>Model GEN2000I Oil Capacity</b>         | 13.5 ounces                         |
| <b>Model GEN2000I Oil Type Recommended</b> | High Detergent Motor Oil, SAE10W-30 |



Figure 12 - Adding Oil

## Air Filter Maintenance

A dirty air cleaner will restrict air flow to the carburetor. To prevent carburetor malfunction, service the air cleaner regularly. Service more frequently when operating the generator in extremely dirty areas.



### WARNING!

Do not use gasoline or low flash point solvents for cleaning. They are flammable and explosive under certain conditions.



### CAUTION:

Never run the generator without the air filter, otherwise rapid engine wear may result.

1. Loosen the cover screws and remove the maintenance cover. (Fig. 14A)
2. Remove the air cleaner cover. (Fig. 14B)
3. Wash the filter in a non-flammable or high flash point solvent and dry it thoroughly.
4. Soak the filter in clean engine oil and squeeze out the excess oil.
5. Reinstall the air filter and the air cleaner cover. Tighten the cover screw securely.
6. Reinstall the maintenance cover and tighten the cover screw securely.

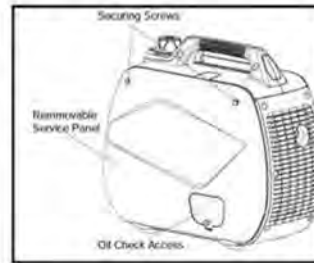

Fig. 14A

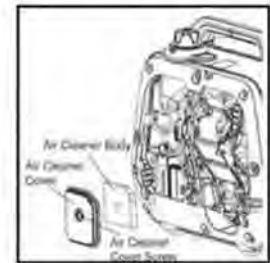
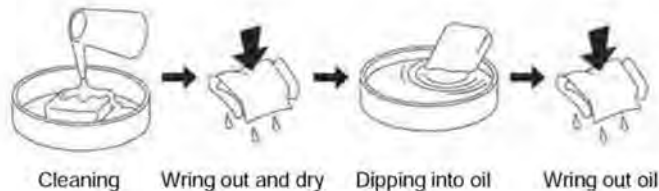

Fig. 14B



## Spark Plug Service

- To ensure proper engine operation, the spark plug must be properly gapped and free of deposits.
1. Loosen the cover screws and remove the maintenance cover, (Fig.15A)
  2. Remove the spark plug cap. (Fig. 15B)
  3. Clean any dirt from around the spark plug base.
  4. Use the wrench to remove the spark plug. (Fig. 15C).
  5. Visually inspect the spark plug. Discard it if the insulator is cracked or chipped. Clean the spark plug with a wire brush if it is to be reused.
  6. Measure the plug gap with a feeler gauge. The gap should be 0.60-0.80mm (0.024-0.032"). Correct as necessary by carefully bending the side electrode. (Fig. 15 D)
  7. Install the spark plug carefully, by hand, to avoid cross-threading. NGK CR7HSA is recommended.
  8. After a new spark plug has been seated by hand, it should be tightened 1/2 turn with a wrench to compress its washer.
  9. If a used plug is being reinstalled, it should only require 1/8 to 1/4 turn after being seated.
  10. Reinstall the spark plug cap on the spark plug securely.



### CAUTION:

Make sure engine is cool before servicing or removing spark plug.



Fig. 15A



Fig 15B



Fig 15B



Fig 15C

0.60-0.80mm  
(0.024-0.032 In)

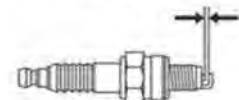

Fig 15D

## Spark Arrestor

1. Allow the engine to cool completely before servicing the spark arrester.
2. Remove the three screws holding the cover plate which retains the end of the spark arrester to the muffler.
3. Remove the spark arrester screen.
4. Carefully remove the carbon deposits from the spark arrester screen with a wire brush.
5. Replace the spark arrester if it is damaged.
6. Position the spark arrester in the muffler and attach with the three screws.

## Changing Fuel Line

Fuel line installation instruction (include the carburetor and the fuel tank ,etc. ) :

1. Connect clamp to the fuel hose;
2. Slide fuel hose onto connection until it touches the bottom;
3. Then secure with clamp.

## Fuel tank usage and maintenance instructions

1. Please pay attention to the cleanliness of the fuel tank inside when you add the fuel into the fuel tank at the first time, and use a small amount of diesel oil (kerosene) to flush fuel tank inside, after flushed fuel tank inside, and then start filling the fuel.
2. Please pay attention to the sundries will be went into the fuel tank inside when you are filling the fuel; and the fuel quality will affect the performance and safety of the equipment.
3. Please note that the tank should be kept at least a certain amount of space for the expansion of fuel. The rated capacity should be controlled in the fuel tank of the maximum liquid capacity of 95%.
4. Fuel tank pipeline must not use the materials which can cause pipeline blockage due to dissolution.
5. The fuel tank should be regularly discharged residues; After discharging residues, the fuel tank can be used again.
6. Please pay attention to fire safety when you are using the fuel tank.
7. The fuel tank should avoid exposure, and should be placed far away from the fire source, no smoking in the vicinity of the fuel tank, no spark or flame, volatile fuel will cause an explosion.
8. The fuel tank should be regularly checked if the rubber sealing has being aged or not, if you find the components are damaged, please immediately stop using, and replace it.

## Storage/Transport Procedures

To prevent fuel spill when transporting or during temporary storage, the generator should be secured upright in its normal operating position, with the engine switch OFF.

1. Be sure the storage area is free of excessive humidity and dust.
  - a. Keep heat, sparks, and flame away.
  - b. Handle fuel only outdoors.
  - c. Wipe up spills immediately.
  - d. Keep out of reach of children and pets.
2. Drain the fuel.
  - a. Drain all gasoline from the fuel tank into an approved gasoline container.
  - b. Loosen the screw of the service panel and remove the service panel, loosen the carburetor bolt and drain the gasoline to a suitable container by the fuel drain pipe.
  - c. When all the fuel is drained, turn the petcock to the OFF position, and tighten the drain screw securely.
3. Clear the engine oil.
4. Remove the spark plug and pour about a table- spoon of clean engine oil into the cylinder. Crank the engine several revolutions to distribute the oil, the reinstall the spark plug.
5. Reinstall the spark plug cap on the spark plug securely.
6. Reinstall the spark plug Access.
7. Reinstall the maintenance cover and tighten the cover screw securely.
8. Pull the starter grip slowly until resistance is felt, then return the starter grip gently. This closes the valves so moisture cannot enter.



# Troubleshooting

## Troubleshooting

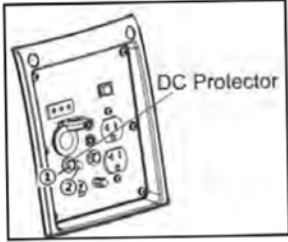

### Generator won't produce power

- Safety device (DC protector) to "OFF" ② ...  
Press the DC protector to "ON" ①.
- Safety device (AC) to "OFF" ....  
AC protected automatically by inverter
- Stop the Engine ,then restart..



### WARNING!

Be sure that is no spilled fuel around the spark plug.  
Spilled fuel may ignite.

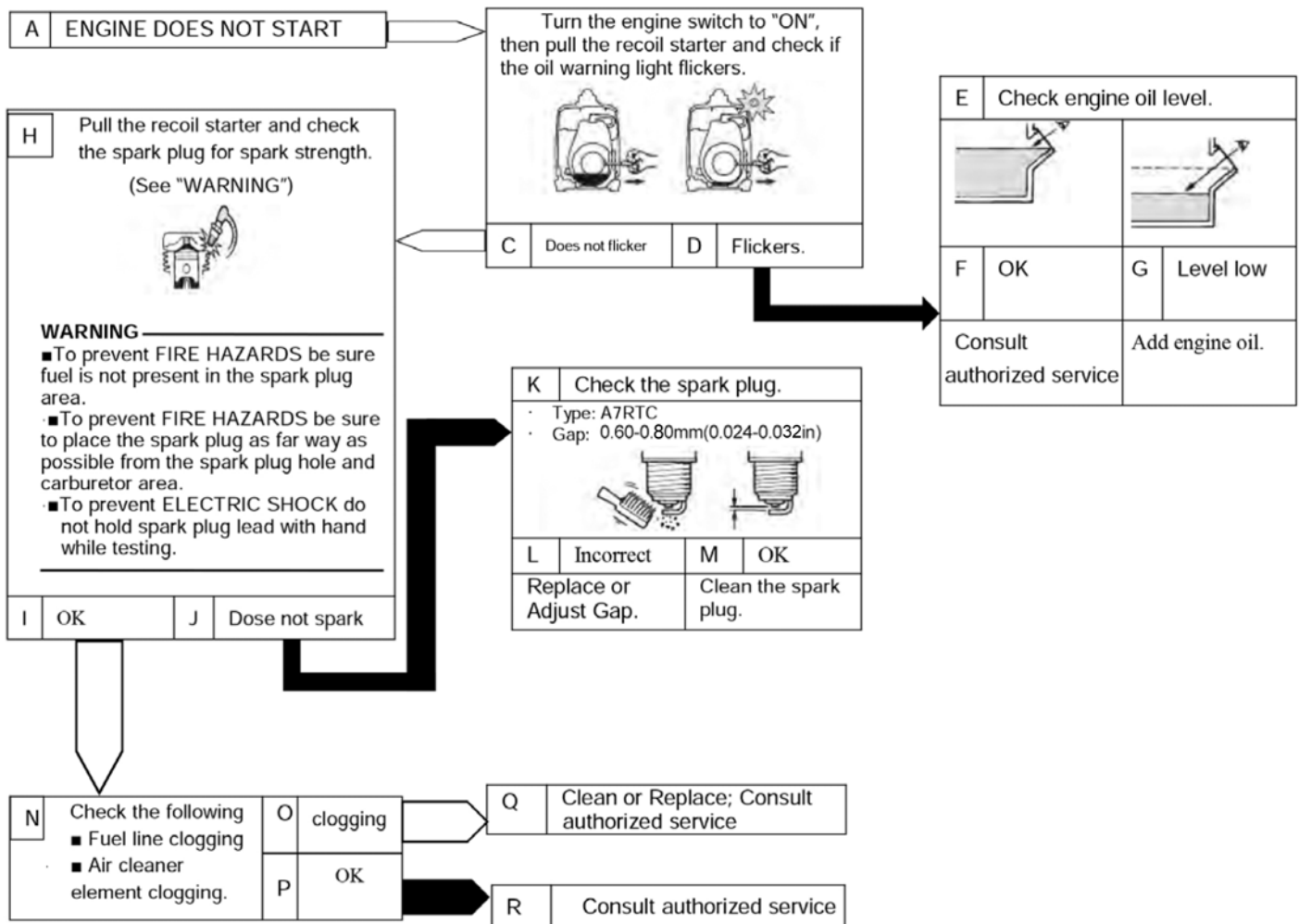

# SPECIFICATIONS

GEN2000I 2200 Surge Watt / 1800 Running Watt Portable Gasoline Inverter Generator

## Generator

|      |   |
|------|---|
| Type | Revolving Magnetic Field, Self Exciting, Multi-Pole, Single Phase |
|------|---|

## AC Output

|                      |        |
|----------------------|--------|
| Rated Wattage (W)    | 1800   |
| Surge Wattage (W)    | 2200   |
| Rated Voltage (V)    | 120    |
| Rated Amperage       | 15     |
| Rated Frequency (Hz) | 60     |
| Phase                | Single |

## DC Output

|                              |    |
|------------------------------|----|
| Voltage (V)                  | 12 |
| Circuit Breaker Amperage (A) | 8  |

## Engine

|                            |  |
|----------------------------|--|
| Engine Type                | 4-stroke single cylinder with forced air cooling system. |
| Engine Displacement        | 79.7cc   |
| Engine Model (HP)          | 3.0  |
| Compression Ratio          | 9:1  |
| Ignition System            | CDI  |
| Starting System            | Recoil   |
| Bore* Stroke (mm)          | 48.6x43.0  |
|                            |  |
| Continuous Operating Hours | Run time = 7 hrs @ 50% load Gasoline fuel                |
|                            |  |
| Oil Capacity (SAE10W-30)   | 13.5 ounces  |
|                            |  |
|                            |  |

# PARTS DIAGRAM

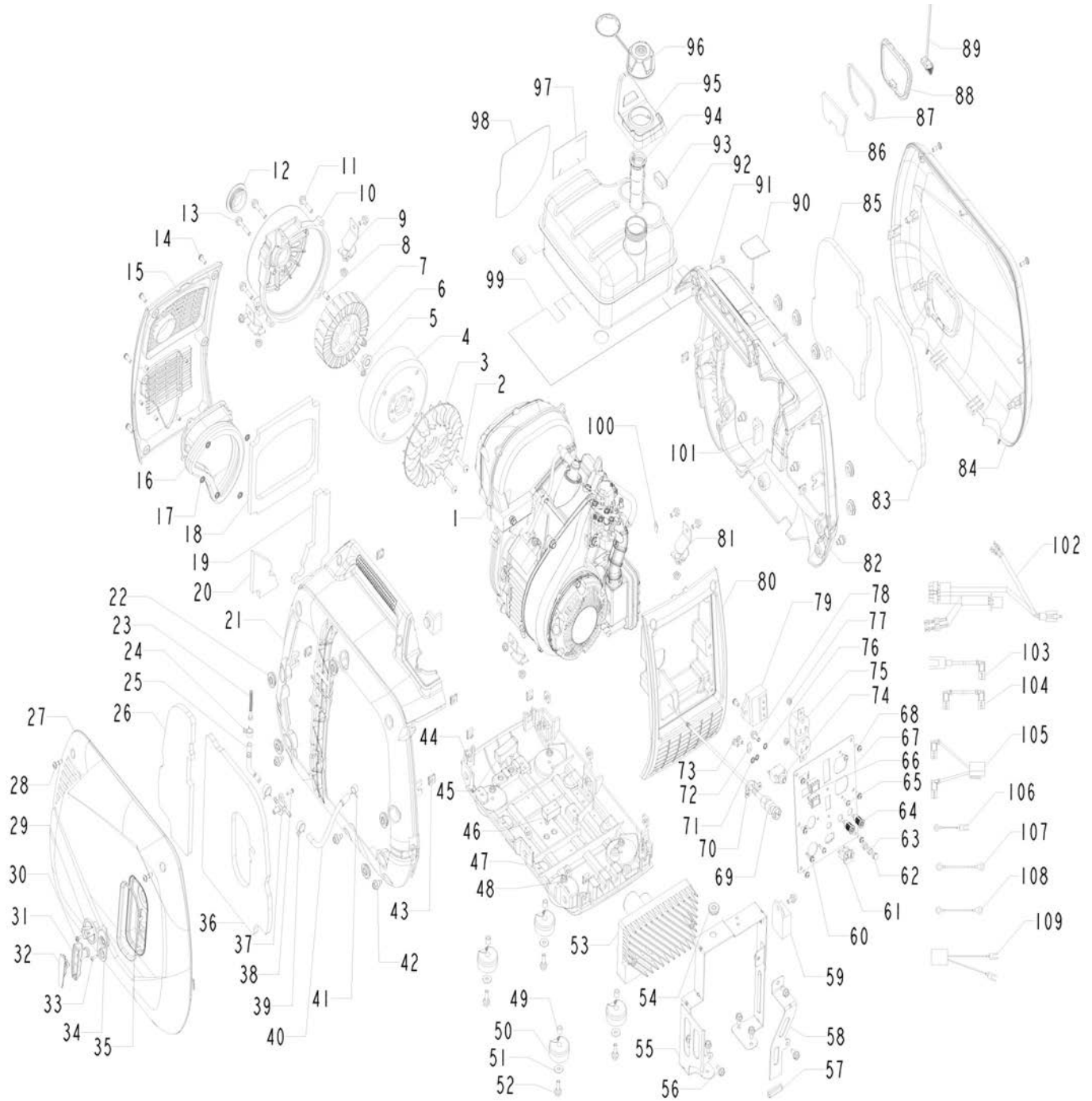

| #  | Part Number     | Description                              | QTY. |
|----|-----------------|--|------|
| 1  | 101200040001000 | Engine                                   | 1    |
| 2  | B02210601627    | Cross Recess Head Screw                  | 2    |
| 3  | 32100422003800  | Fan                                      | 1    |
| 4  | 22070422003000  | Alternator                               | 1    |
| 5  | 34010114001000  | Hexagon Flange Nut                       | 1    |
| 6  | B02040503565    | Inner Hexagon Screw                      | 2    |
| 7  | 22050422003000  | Stator                                   | 1    |
| 8  | 31140127002000  | Pin                                      | 2    |
| 9  | 22030422003800  | Shock Absorbing Foot                     | 2    |
| 10 | 32070422003000  | End Cover                                | 1    |
| 11 | B01310603065    | Increased Flange Bolt                    | 3    |
| 12 | 32080422003000  | Plug, end cover                          | 1    |
| 13 | B01310603566    | Increased Flange Bolt                    | 2    |
| 14 | B13080501627    | Screw                                    | 13   |
| 15 | 34120422003800  | Rear Exhaust Cover                       | 1    |
| 16 | 34130422003800  | Rubber Duct                              | 1    |
| 17 | 30010222511060  | Retainer Ring                            | 5    |
| 18 | 34140422003000  | Insulating Foam, Exhaust Port            | 1    |
| 19 | 34160422003000  | Insulating Foam, Right Inlet             | 1    |
| 20 | 34150422003000  | Insulating Foam, Left Inlet              | 1    |
| 21 | 24030422005000  | Leif Boly                                | 1    |
| 22 | 34040422003800  | Rubber Grommet                           | 10   |
| 23 | 20140421200000  | Fuel Filter                              | 1    |
| 24 | 31210421202000  | Clamp                                    | 1    |
| 25 | 33100422003800  | Oil Pipe                                 | 1    |
| 26 | 34200422003000  | Left Foam Seal II                        | 1    |
| 27 | 34180422005750  | Left Body Cover                          | 1    |
| 28 | 30230421202000  | Screw M6*17                              | 4    |
| 29 | 34220422003800  | Fuel Petcock Knob                        | 1    |
| 30 | 30040422001670  | Screw M4*11                              | 1    |
| 31 | 30160421202000  | Pull Start Handle                        | 1    |
| 32 | 30170421202000  | Pull Start Handle Cover                  | 1    |
| 33 | B05210501607    | Truss Head Tapping Screw                 | 1    |
| 34 | 34210422003800  | Rope Guide Plate Assembly                | 1    |
| 35 | 34330422003000  | Decorating Ring                          | 1    |
| 36 | 34190422003000  | Left Foam Seal I                         | 1    |
| 37 | 20110421200001  | Fuel Cock                                | 1    |
| 38 | B05210401607    | Truss Head Tapping Screw                 | 1    |
| 39 | 31190421202000  | Clamp                                    | 2    |
| 40 | 33110422003800  | Fuel Hose, Carburetor                    | 1    |
| 41 | 31200421202000  | Clamp                                    | 1    |
| 42 | 31150422003020  | Shoulder Screws                          | 6    |
| 43 | 30220421202000  | Spring Nut                               | 12   |
| 44 | 31070422003020  | Square Nut                               | 6    |
| 45 | 31030422003800  | Cushion Pad                              | 1    |
| 46 | 31040422003800  | Bumper Block,Engine                      | 1    |
| 47 | 21020422003000  | Body Base Plate                          | 1    |
| 48 | B04280600047    | Flange Nut                               | 8    |
| 49 | 31020412600010  | Spacer                                   | 4    |
| 50 | 31050422003800  | Damping Foot                             | 4    |
| 51 | B07020006047    | Flat Gasket                              | 4    |
| 52 | B01310602067    | Flange Nut                               | 4    |
| 53 | 21040422005000  | Inverter Assy                            | 1    |
| 54 | 31140422003800  | Damping Ring, Fuel Tank                  | 1    |
| 55 | B01310601267    | Flange Bolt M6*12                        | 13   |
| 56 | B02270403027    | Cross Recess Head Screw                  | 2    |
| 57 | 31130422003800  | Rubber Cushion,Inverter Mounting Bracket | 1    |

| #   | Part Number    | Description                          | QTY. |
|-----|----------------|--------------------------------------|------|
| 58  | 31120422003800 | Inverter Mounting Bracket ,Front     | 1    |
| 59  | 23250421200000 | Voltage regulator                    | 1    |
| 60  | B13080400827   | Screw                                | 2    |
| 61  | 22060411500000 | T Type Socket                        | 1    |
| 62  | B04190600044   | Cap Nut                              | 1    |
| 63  | B04010600048   | Hex Nut                              | 2    |
| 64  | 20110421202000 | Parallel Connection Socket           | 2    |
| 65  | B02210401227   | Cross Recess Head Screw              | 6    |
| 66  | 22030410900000 | Engine Switch                        | 2    |
| 67  | 25020452005800 | Panel Assy                           | 1    |
| 68  | B02210501227   | Cross Recess Head Screw              | 4    |
| 69  | 32160422003800 | Choke Lever Mounting Plate           | 1    |
| 70  | 22080422003000 | Choke Lever                          | 1    |
| 71  | B07180005056   | Lock Washer 5                        | 2    |
| 72  | 32060421202000 | Grounding Piece 5                    | 1    |
| 73  | B13080500827   | Screw                                | 2    |
| 74  | B28421080010   | Circuit Breaker                      | 1    |
| 75  | 22070413200000 | 120V Socket                          | 1    |
| 76  | B07180006056   | Lock Washer 6                        | 2    |
| 77  | B04280400047   | Flang Nut M4                         | 2    |
| 78  | B01310601628   | Flang Blot M6*16                     | 1    |
| 79  | 25030422003000 | Light Indicator Assembly             | 1    |
| 80  | 34110422003800 | Front Cover                          | 1    |
| 81  | 22030422003801 | Shock Absorbing Foot                 | 2    |
| 82  | 24050422005000 | Right Casing                         | 1    |
| 83  | 34240422003000 | Insulating Foam I, Right Body Cover  | 1    |
| 84  | 34230422005750 | Right Body                           | 1    |
| 85  | 34250422003000 | Insulating Foam II, Right Body Cover | 1    |
| 86  | 34280422003000 | Foam II, Oil Fill Cover              | 1    |
| 87  | 34290422003000 | Foam II, Oil Fill Cover              | 1    |
| 88  | 34260422003750 | Oil Fill Cover                       | 1    |
| 89  | 34270422003800 | Tether, Oil Fill Cover               | 1    |
| 90  | 34100422003800 | Spark Plug Access Cover              | 1    |
| 91  | B02210602027   | Cross Recess Head Screw              | 2    |
| 92  | 23010422005800 | Fuel Tank                            | 1    |
| 93  | 33060422003800 | Tank Mounting Rubber Cushion         | 2    |
| 94  | 21030421202000 | Fuel Filter                          | 1    |
| 95  | 34080422005000 | Rubber Mat, fuel filling Port        | 1    |
| 96  | 21120421202001 | Fuel Tank Cap                        | 1    |
| 97  | 33070422003000 | Silver Paper I                       | 1    |
| 98  | 33080422003000 | Silver Paper II                      | 1    |
| 99  | 33090422003000 | Silver Paper III                     | 1    |
| 100 | 30090422001000 | Grounding Piece 6                    | 1    |
| 101 | 34030422003800 | Rubber Pad                           | 2    |
| 102 | 21070422003000 | Cable Assy                           | 1    |
| 103 | 35110422005000 | Parallel Cable                       | 2    |
| 104 | 35130422003000 | Connection Cabel,DC protector        | 1    |
| 105 | 35120422003000 | DC Connecting Cable (American)       | 1    |
| 106 | 35080422003000 | Ground Wire5-5                       | 1    |
| 107 | 35090422003000 | Ground Wire5-6                       | 1    |
| 108 | 32090422003000 | Ground Wire6-6                       | 1    |
| 109 | 22070421202000 | AC Connecting Cable                  | 1    |
| 110 |                |                                      |      |
| 111 |                |                                      |      |
| 112 |                |                                      |      |
| 113 |                |                                      |      |
| 114 |                |                                      |      |

# PARTS DIAGRAM

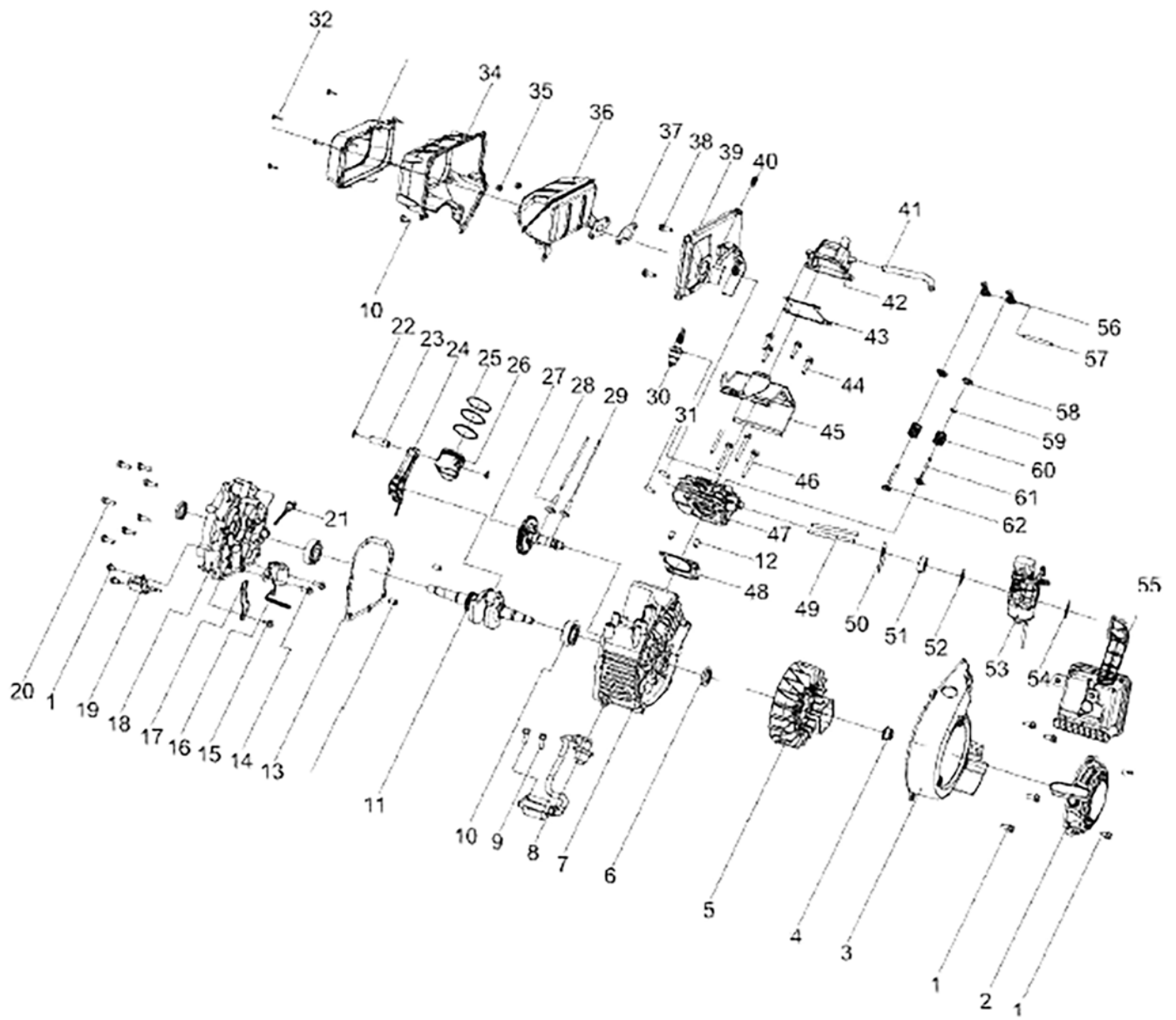

## PARTS DIAGRAM

| #  | Part Number    | Description                                | QTY. |
|----|----------------|--|------|
| 1  | B01310601466   | Bolt, Flange M6*14                         | 7    |
| 2  | 26040119001000 | Stater Assy.                               | 1    |
| 3  | 36070120001000 | Case, Fan                                  | 1    |
| 4  | 34060119001020 | Nut M12                                    | 1    |
| 5  | 38030119001000 | Rotor Assy.                                | 1    |
| 6  | B15302035053   | Oil Seal $\Phi 20 \times \Phi 35 \times 5$ | 2    |
| 7  | 31070120001000 | Crankcase                                  | 1    |
| 8  | 38020119001000 | Ignition Coil Assy.                        | 1    |
| 9  | B01310602066   | Bolt, Flange M6*20                         | 2    |
| 10 | B12016020453   | Bearing 6204/P53                           | 2    |
| 11 | 24020120001000 | Crankshaft Assy.                           | 1    |
| 12 | 31140127002000 | Pin, Dowel                                 | 4    |
| 13 | 31020120001000 | Gasket, Crankcase Cover                    | 1    |
| 14 | B01310601666   | Bolt, Flange M6*16                         | 2    |
| 15 | B01310601266   | Bolt, Flange M6*12                         | 2    |
| 16 | 31030119001000 | Oil Lever Gauge Assy.                      | 1    |
| 17 | 31040120001000 | Clamp                                      | 1    |
| 18 | 31010120001000 | Cover Crankcase                            | 1    |
| 19 | 38010119001000 | Coil Assy.                                 | 1    |
| 20 | B01310602066   | Bolt, Flange M6*20                         | 9    |
| 21 | 31050120001000 | Oil Dipstick Assy.                         | 1    |
| 22 | 34030119001000 | Circlip                                    | 2    |
| 23 | 34020119001000 | Pin, Piston                                | 1    |
| 24 | 24030119001000 | Connecting Rod Assy.                       | 1    |
| 25 | 24040119001000 | Piston Ring Set                            | 1    |
| 26 | 34010119001000 | Piston                                     | 1    |
| 27 | 22040119001000 | Camshaft Assy.                             | 1    |
| 28 | 32060120001000 | Lifter, Valve                              | 2    |
| 29 | 32080120001000 | Rod, Valve Push                            | 2    |
| 30 | 31250114001000 | Plug, Spark A7RTC                          | 1    |
| 31 | 32120119001000 | Bolt, Stud                                 | 2    |
| 32 | B020048016C6   | Screw, ST4.8*16                            | 5    |
| 33 | 36030120001000 | Duct                                       | 1    |
| 34 | 36310119001000 | Protector Assy.                            | 1    |
| 35 | B04280600026   | Nut M6                                     | 4    |

| #  | Part Number    | Description            | QTY. |
|----|----------------|------------------------|------|
| 38 | B01310601666   | Bolt, Flange M6*16     | 2    |
| 39 | 36100120001000 | Protector Assy.        | 1    |
| 40 | 36060120001000 | Nut Spring             | 1    |
| 41 | 37060120001000 | Pipe, Breather         | 1    |
| 42 | 32200120001000 | Cover, Cylinder Head   | 1    |
| 43 | 32110120001000 | Gasket, Cylinder       | 1    |
| 44 | B01310601866   | Bolt, Flange M6*18     | 4    |
| 45 | 36010120001000 | Air Shroud, Cylinder 1 | 1    |
| 46 | B01310605086   | Bolt, Flange M6*50     | 4    |
| 47 | 22020120001000 | Head, Cylinder         | 1    |
| 48 | 32130119001000 | Gasket, Cylinder Head  | 1    |
| 49 | 32050135001000 | Bolt, Stud             | 2    |
| 50 | 32120120001000 | Gasket, Manifold       | 1    |
| 51 | 32130120001000 | Joint                  | 1    |
| 52 | 37020120001000 | Gasket, Manifold       | 1    |
| 53 | 27430119001000 | Carburetor Assy.       | 1    |
| 54 | 37030120001000 | Gasket Air Cleaner     | 1    |
| 55 | 27030120001000 | Air Cleaner            | 1    |
| 56 | 22030120001000 | ARM, Valve Rocker      | 2    |
| 57 | 32030120001000 | Shaft, Rocker          | 1    |
| 58 | 33110114001000 | Retainer, Valve Spring | 2    |
| 59 | 31010114001000 | Seal, Valve Stem       | 1    |
| 60 | 32050120001000 | Spring, Compression    | 2    |
| 61 | 32010120001000 | Valve, Exhaust         | 1    |
| 62 | 32020120001000 | Valve, Intake          | 1    |

# Wiring Diagram

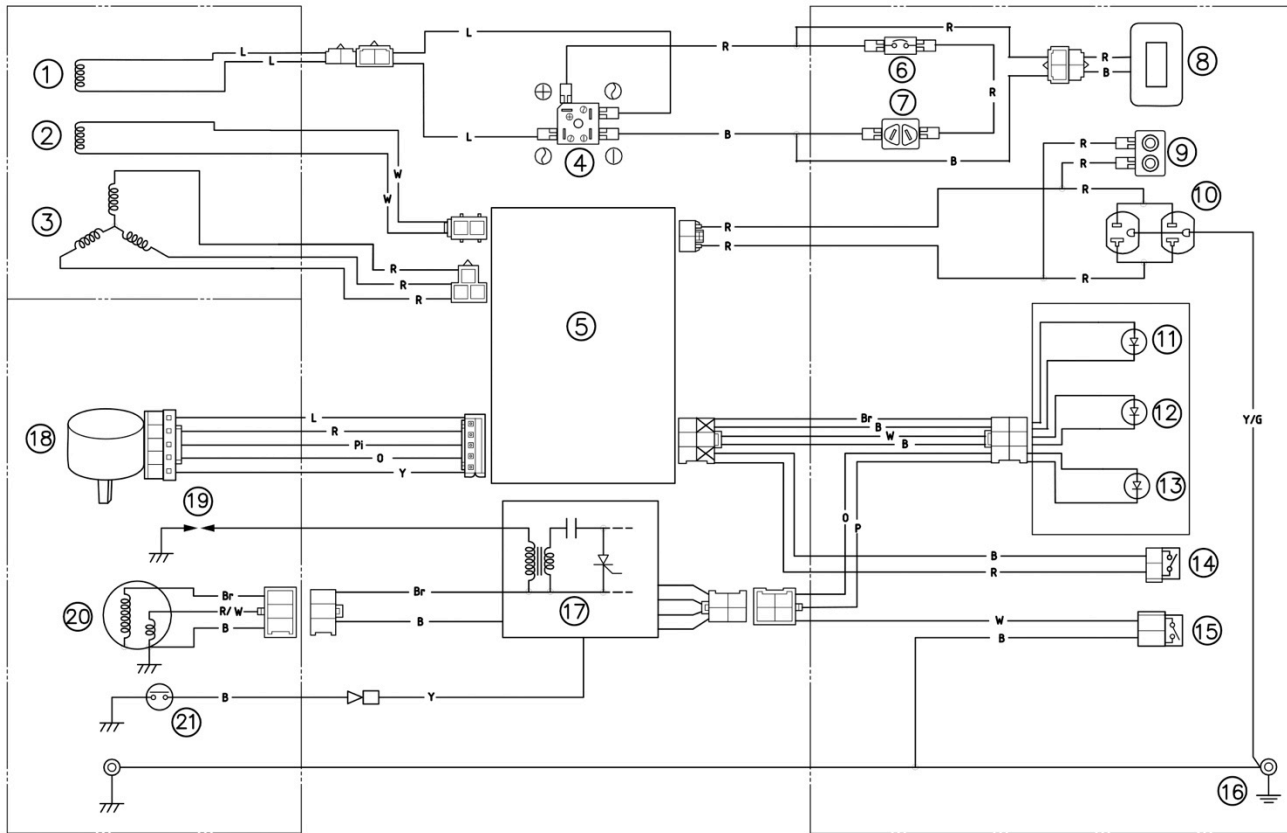

- ① DC WINDING
- ② SUB WINDING
- ③ MAIN WINDING
- ④ RECTIFIER
- ⑤ INVERTER UNIT
- ⑥ CIRCUIT BREAKER (DC)
- ⑦ DC OUTPUT RECEPTACLE
- ⑧ USB OUTPUT RECEPTACLE
- ⑨ TWIN TECH (PARALLEL TERMINAL)
- ⑩ AC OUTPUT RECEPTACLE
- ⑪ OUTPUT INDICATOR
- ⑫ OVERLOAD INDICATOR
- ⑬ OIL ALERT INDICATOR
- ⑭ ECO THROTTLE SWITCH
- ⑮ ENGINE STOP SWITCH
- ⑯ GROUND (Earth) terminal
- ⑰ C. D. I. UNIT
- ⑱ THROTTLE CONTROL MOTOR
- ⑲ SPARK PLUG
- ⑳ C. D. I. MAGNETO
- ㉑ OIL LEVEL SWITCH

Color code

|     |              |
|-----|--------------|
| B   | Black        |
| Br  | Brown        |
| G   | Green        |
| L   | Blue         |
| O   | Orange       |
| P   | Purple       |
| R   | Red          |
| W   | White        |
| Y   | Yellow       |
| Y/G | Yellow/Green |
| R/W | Red/White    |

# EMISSION CONTROL SYSTEM WARRANTY

## BUFFALO CORPORATION

### Your Warranty Rights and Obligations

The California Air Resources Board, U.S. EPA and Buffalo Corp. are pleased to explain the Emission Control System Warranty on your 2018 model year new outdoor power equipment engine.

#### California

In California, new spark-ignited small off-road equipment engines must be designed, built and equipped to meet the State's stringent anti-smog standards.

#### Other States, U.S. Territories

In other areas of the United States, your engine must be designed, built and equipped to meet the U.S. EPA emission standards for spark-ignited engines at or below 19 kilowatts.

#### All of the United States

Buffalo Corp. must warrant the emission control system on your power equipment engine for the periods of time listed below provided there has been no abuse, neglect or improper maintenance of your power equipment engine. Where a warrantable condition exists, Buffalo Corp. will repair your power equipment engine at no cost to you including diagnosis, parts and labor.

Your emissions control system may include parts such as: carburetors or fuel injection system, ignition system, catalytic converters, fuel tanks, valves, filters, clamps, connectors, and other associated components. Also, included may be hoses, belts, connectors, sensors, and other emission-related assemblies.

#### Manufacturer's Warranty Coverage:

The emission control system is warranted for two years. If any emissions-related part on your engine is defective, the part will be repaired or replaced by Buffalo Corp.

#### Owner's Warranty Responsibility

As the power equipment engine owner, you are responsible for the performance of the required maintenance listed in your owner's manual. BUFFALO CORP. recommends that you retain all receipts covering maintenance on your power equipment engine, but BUFFALO CORP. can not deny warranty solely for the lack of receipts or for your failure to ensure the performance of all scheduled maintenance.

As the power equipment engine owner, you should however be aware that BUFFALO CORP. may deny your warranty coverage if your power equipment engine or a part has failed due to abuse, neglect, improper maintenance or unapproved modifications.

You are responsible for presenting your power equipment engine to distribution center or service center authorized by BUFFALO CORP. as soon as the problem exists.

The warranty repairs should be completed in a reasonable amount of time, not to exceed 30 day.

If you have any questions regarding your warranty rights and responsibilities, you should contact Buffalo Corp. customer service representative at 1-866-460-9436 or write to [info@bufflotools.com](mailto:info@bufflotools.com)

#### DEFECTS WARRANTY COVERAGE

Adopted by the Air Resources Board, Buffalo Corp. warrants to the ultimate purchaser and each subsequent purchaser that the small off-road engine (SORE)(1) has been designed, built and equipped so as to conform with all applicable regulations; and (2) is free from defects in materials and workmanship that cause the failure of a warranted part to conform with those regulations as may be applicable to the terms and conditions stated below.

(a) The warranty period begins on the date the engine is delivered to an ultimate purchaser or first placed into service. The warranty period is two years.

(b) Subject to certain conditions and exclusions as stated below, the warranty on emissions related parts is as follows:

(1) Any warranted part that is not scheduled for replacement as required maintenance in your Owner's Manual is warranted for the warranty period stated above. If the part fails during the period of warranty coverage, the part will be repaired or replaced by Buffalo Corp. According to Subsection (4) below. Any such part repaired or replaced under warranty will be warranted for the remainder of the periods.

(2) Any warranted part that is scheduled only for regular inspection in your owner's manual is warranted for the warranty period stated above. Any such part repaired or replaced under warranty will be warranted for the remaining warranty period.

(3) Any warranted part that is scheduled for replacement as required maintenance in your owner's manual is warranted for the period of time before the first scheduled replacement date for that part. If the part fails before the first scheduled replacement, the part will be repaired or replaced by Buffalo Corp. According to Subsection (4) below. Any such part repaired or replaced under warranty will be warranted for the remainder of the period prior to the first scheduled replacement point for the part.

(4) Repair or replacement of any warranted part under the warranty provisions herein must be performed at a warranty station at no charge to the owner.

(5) Notwithstanding the provisions herein, warranty services or repair will be provided at all of our distribution centers that are franchised to service the subject engines.



- (6) The engine owner must not be charged for diagnostic labor that leads to the determination that a warranted part is in fact defective, provided that such diagnostic work is performed at a warranty station.
- (7) Buffalo Corp. is liable for damages to other engine components proximately caused by a failure under warranty of any warranted part.
- (8) Throughout the engine warranty period stated above, Buffalo Corp. will maintain a supply of warranted part sufficient to meet the expected demand for such parts.
- (9) Any replacement may be used in the performance of any warranty maintenance or repairs and must be provided without charge to the owner. Such use will not reduce the warranty obligations of Buffalo Corp.
- (10) Add-on or modified parts that are not exempted by the Air Resources Board may not be used. The use of any non-exempted add-on or modified parts by the ultimate purchaser will be grounds for disallowing a warranty claims. Buffalo Corp. will not be liable to warrant failures of warranted parts caused by the use of a non-exempted add-on or modified part.
- (11) The manufacturer issuing the warranty shall provide any documents that describe that manufacturer's warranty procedures or policies within five working days of request by the Air Resources Board.

#### **EMISSION WARRANTY PARTS LIST**

- (1) Fuel Metering System:
  - (a) Gasoline carburetor assembly and its internal components
  - (b) Carburetor gaskets
  - (c) Fuel line
  - (d) Clamps
  - (e) Fuel tank
  - (f) Fuel line fittings
  - (g) Pressure regulator(if equipped)
  - (h) Mixer assembly and its internal components (if equipped)
- (2) Air induction system including:
  - (a) Intake pipe/manifold
  - (b) Air cleaner
- (3) Ignition system including:
  - (a) Spark plug
  - (b) Ignition coil
- (4) Catalytic muffler assembly including:
  - (a) Muffler gasket
  - (b) Exhaust manifold
  - (c) Catalytic converter (if available)
- (5) Crankcase breather assembly including:
  - (a) Breather connection tube
- (6) Fuel tank evaporative emissions control system including:
  - (a) Purge valves
  - (b) Carbon canister
  - (c) Canister mounting brackets
  - (d) Fuel cap
  - (e) Fuel tank
- (7) Miscellaneous items used in above systems including:
  - (a) Switches
  - (b) Hoses, belts connectors and assemblies
- (8) Air injection system
  - (a) Pulse valve

201804

**Item # GEN1000I-PL**



## **1,000 MAX WATTS INVERTER GENERATOR**

### **INSTRUCTION MANUAL**

#### **READ ALL INSTRUCTIONS AND WARNINGS BEFORE USING THIS PRODUCT.**

This manual provides important information on proper operation & maintenance. Every effort has been made to ensure the accuracy of this manual. These instructions are not meant to cover every possible condition and situation that may occur. We reserve the right to change this product at any time without prior notice.

#### **IF THERE IS ANY QUESTION ABOUT A CONDITION BEING SAFE OR UNSAFE, DO NOT OPERATE THIS PRODUCT!**

If you experience a problem, have questions or need parts for this product, call Customer Service at **1-866-460-9436, Monday-Friday, 8 AM - 4 PM Central Time**. A copy of the sales receipt is required.

#### **FOR CONSUMER USE ONLY – NOT FOR PROFESSIONAL USE.**

#### **KEEP THIS MANUAL, SALES RECEIPT & APPLICABLE WARRANTY FOR FUTURE REFERENCE.**

#### **CALIFORNIA PROPOSITION 65**

**WARNING:** This product can expose you to chemicals including lead, which is known to the State of California to cause cancer, and Carbon Monoxide, which is known to the State of California to cause birth defects or other reproductive harm. For more information go to [www.P65Warnings.ca.gov](http://www.P65Warnings.ca.gov)

### **2 YEAR LIMITED EMISSION-RELATED WARRANTY**

THIS ENGINE MEETS U.S. EPA EMISSION STANDARDS UNDER 40 CFR 1054.625. The emission-related limited warranty is valid for two (2) years. Keep the purchase receipt and mail in the product registration card for proof of purchase. Buffalo Corp limits emission-related warranty repairs to authorized service centers for owners located within 100 miles of an authorized service center. For owners located more than 100 miles from an authorized service center, Buffalo Corp will, in its sole discretion, either pay for shipping costs to and from an authorized service center, provide for a service technician to come to the owner to make the warranty repair, or pay for the repair to be made at a local non-authorized service center. The provisions of this paragraph apply only for the contiguous states, excluding the states with high-altitude areas identified in 40 CFR part 1068, Appendix III.

To exercise this warranty, DO NOT RETURN TO RETAILER. Instead, call Customer Service toll free at 1-866-460-9436 (email address [info@buffalotools.com](mailto:info@buffalotools.com)) and you will be instructed on where to take the engine for warranty service. Take the generator and proof of purchase (your receipt) to the repair facility recommended by the Customer Service Representative. The warranty does not extend to generators damaged or affected by fuel contamination, accidents, neglect, misuse, unauthorized alterations, use in an application for which the product was not designed and any other modifications or abuse.

#### **1 YEAR LIMITED WARRANTY (30 Day Limited for Commercial/Rental Purpose)**

Generators are warranted to be free from defects in materials and workmanship for a period of 1 YEAR from date of original purchase. Buffalo Corp. is not liable for any indirect, incidental or consequential damages from the sale or use of this product. Any implied warranties are limited to 1 YEAR as stated, or as otherwise stated, in this written limited warranty. Some states do not allow the exclusion or limitation of incidental or consequential damages. Some states do not allow limitation on the length of an implied warranty. Buffalo Corp will repair or replace, at its discretion, any part that is proven to be defective in materials or workmanship under normal use during the 1 YEAR warranty period. Warranty repairs or replacements will be made without charge for parts or labor. Parts replaced during warranty repairs will be considered as part of the original product and will have the same warranty period as the original product. This warranty gives you specific legal rights, and you may have other rights that vary state to state.

## Notice Regarding Emissions:

Engines certified to comply with California and U.S. EPA emission regulations for SORE (Small Off Road Equipment) are certified to operate on regular unleaded gasoline and may include the following emission control systems: Three-Way Catalyst (TWC) (if equipped), and Engine Modifications (EM).

## Legal Requirements:

Federal and/or State Occupational Safety and Health Administration (OSHA) regulations, local codes, and/or ordinances may apply to the intended use of this generator. Consult a qualified electrician, electrical inspector, and/or the local agency having jurisdiction. Some areas require generators to be registered with local utility companies. Additional regulations may apply if this generator will be used at a construction site.

## IMPORTANT SAFETY INSTRUCTIONS

# STOP!

Before using this generator and if you have any questions regarding the hazard and safety notices listed in this manual and/or on this generator, call 1-866-460-9436, Monday - Friday, 8 AM - 4 PM Central Time.

### **DANGER**

**Carbon Monoxide Gas:** When in operation, the exhaust from this generator contains poisonous carbon monoxide gas. Carbon monoxide gas is both odorless and colorless AND may be present even if you do not see or smell gas. Breathing this poison gas can lead to headaches, dizziness, drowsiness, loss of consciousness and eventually death.

- USE THIS GENERATOR ONLY OUTDOORS IN NON-CONFINED AREAS. DO NOT SECURE THE GENERATOR WITH A CHAIN OR ROPE, AS THIS WILL MAKE IT DIFFICULT TO MOVE IN AN EMERGENCY.
- Keep at least several feet of clearance on all sides to allow proper ventilation for this generator.

### **WARNING**

**Chemicals:** This product can expose you to chemicals including lead, which is known to the State of California to cause cancer, and Carbon Monoxide, which is known to the State of California to cause birth defects or other reproductive harm. For more information go to [www.P65Warnings.ca.gov](http://www.P65Warnings.ca.gov)

**⚠ WARNING**

**Flammable Gasoline:** This generator may emit highly flammable and explosive gasoline vapors, which can cause severe burns or even death. A nearby open flame can lead to an explosion even if not directly in contact with gasoline.

- Do not operate this generator near open flame.
- Do not smoke near this generator.
- Always operate this generator on a firm, level surface.

**Gasoline is highly flammable and explosive. Handling fuel can result in serious injury or burns.**

- Always shut down this generator before refueling. Refuel in a well-ventilated area. Keep heat, sparks and flame away while refueling and away from the location where gasoline is stored. Never refuel indoors where gasoline fumes may reach flames and/or sparks.
- Allow this generator to cool for at least 2 minutes before removing the fuel tank cap. Loosen the cap slowly to relieve pressure in the fuel tank. Avoid spilling fuel.
- Do not fill the fuel tank above the upper limit line. Gasoline may expand during operation. Do not fill to the top of the tank.
- Always check for spilled gasoline and immediately wipe it up before starting this generator.
- Empty the fuel tank before storing or transporting this generator.
- Always handle fuel outdoors.
- Before transporting, turn the fuel valve to the “OFF” position and disconnect the spark plug.

NOTE: DO NOT USE GASOLINE CONTAINING MORE THAN 10% ETHANOL (e10)

**⚠ WARNING**

**Usage:** Consult a physician(s) before using this generator if using a pacemaker. Electromagnetic fields in close proximity to a heart pacemaker could cause a pacemaker to malfunction or fail. Caution is necessary when near the engine’s recoil starter.

**⚠ CAUTION**

**Usage:** Prolonged exposure to high noise levels can be hazardous to hearing. Always wear ANSI-approved hearing protection when operating or working around the generator when it is running.

**⚠ DANGER**

**Powerful Voltage:** This generator produces powerful voltage, which can result in electrocution.

- ALWAYS ground this generator before using it. (See “Ground the Generator” section in this manual).
- Only electrical devices should be plugged into this generator, either directly or with an extension cord. NEVER connect a building electrical system to this generator without a qualified electrician. *Doing so voids your warranty.* Such connections must isolate generator power from utility power and comply with local electrical laws and codes. Failure to comply can create a back feed into utility lines creating an electrocution hazard, which may result in serious injury or death to utility workers. Such a back feed may cause this generator to explode, burn and create fires when utility power is restored.
- Use a ground fault circuit interrupter (GFCI) in highly conductive areas such as metal decking or steel work. GFCIs are available in-line with some extension cords.
- Do not use this generator in wet conditions (rain, snow, active sprinkler system, wet hands, etc.). Always keep this generator dry and operate it with dry hands.
- Do not allow children or non-qualified persons to operate this generator.

**⚠ WARNING**

*GASOLINE IS HIGHLY FLAMMABLE AND EXPLOSIVE. YOU COULD BE BURNED OR SERIOUSLY INJURED IF THE GASOLINE IS IGNITED. Before refueling, stop the engine and keep heat, sparks and flame away. Handle fuel only outdoors. Do not fill the fuel tank above the upper limit line. Wipe up spills immediately.*

**⚠ WARNING**

*IMPROPER CONNECTIONS TO A BUILDING CAN ALLOW ELECTRICAL CURRENT TO BACKFEED INTO UTILITY LINES, CREATING AN ELECTROCUTION HAZARD. Connections to a building must isolate generator power from utility power and comply with all applicable laws and electrical codes.*

**⚠ DANGER**

**High Temperatures:** This generator produces heat when in operation. Temperatures near the exhaust can exceed 150 Degrees Fahrenheit (65 Degrees Celsius).

- Do not touch hot surfaces. Observe all warning placards on this generator denoting hot surfaces.
- Allow this generator to cool for several minutes after use before touching the engine, muffler or other areas that are hot during operation and before storing indoors.
- Hot exhaust may ignite some materials. Keep flammable materials away from this generator.
- Keep at least several feet of clearance on all sides of this generator during operation. Do not enclose this generator in any structure.

**⚠ CAUTION**

**Usage:** Misuse of this generator can damage it or shorten its life.

- Use this generator only for its intended purpose.
- Operate this generator only on a dry, level surface. Do not secure the generator with a chain or rope, which would prevent it from being moved in an emergency.
- Allow this generator to run for several minutes before connecting any electrical devices.
- Promptly turn off any malfunctioning devices and disconnect them.
- Do not operate an excessive number of electrical devices in excess of the wattage capacity of this generator.
- Do not turn on electrical devices until *after* they are connected to this generator.
- Turn off all connected electrical devices before stopping this generator.

**⚠ CAUTION**

**Usage:** Prolonged exposure to high noise levels can be hazardous to hearing. Always wear ANSI-approved hearing protection when operating or working around the generator when it is running.

**⚠ WARNING**

**Usage:** Avoid the use of extension cords if possible. If you choose to use them, be sure they are sized adequately to handle the flow of electricity. An undersized cord can overheat, short out and cause a fire.

**Included with this Generator:**

DC connector wires for connecting 12 Volt automotive-type batteries  
Spark plug wrench  
Screwdriver

**⚠ WARNING**

**Usage:** Avoid the use of extension cords if possible. If you choose to use them, be sure they are sized adequately to handle the flow of electricity. An undersized cord can overheat, short out and cause a fire.

**⚠ DANGER**

*EXHAUST CONTAINS POISONOUS CARBON MONOXIDE GAS THAT CAN BUILD UP TO DANGEROUS LEVELS IN CLOSED AREAS. BREATHING CARBON MONOXIDE CAN CAUSE UNCONSCIOUSNESS OR DEATH. Never run the generator in a closed or even partly closed area where people may be present.*

# FEATURES:

- 0.55 Gallon Fuel Tank
- 1,000 Watts Max/800 W Min AC output
- 5,000 RPM
- 40cc, 4 stroke
- Low oil shutdown
- Recoil Start
- Run Time : 6.3 Hours at 50% load
- Noise Level : 56db at 0% load @23 Ft
- 1.3 HP
- 7.5 ounces Oil
- EPA / CARB Approved
- High Altitude Use: This generator is not recommended for high altitude use above 3,000 feet.

## DESCRIPTION

- |                            |                              |                              |
|----------------------------|------------------------------|------------------------------|
| (1) Economy control switch | (2) Engine switch            | (3) Fuel tank                |
| (4) Spark plug             | (5) Muffler                  | (6) Carrying handle          |
| (7) Choke lever            | (8) AC pilot light           | (9) Overload indicator light |
| (10) Oil warning light     | (11) Ground (earth) terminal | (12) DC protector            |
| (13) DC receptacle         | (14) AC receptacle           |                              |
| (16) Fuel filter           | (17) Fuel tank cap           | (18) Fuel pump               |
| (19) Recoil starter        | (20) Fuel cock               | (21) Oil filler cap          |
| (22) Air filter cover      |                              |                              |

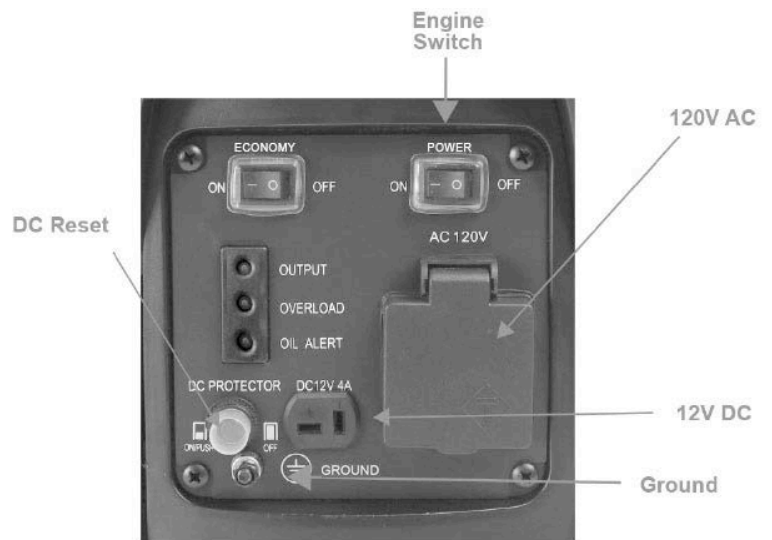
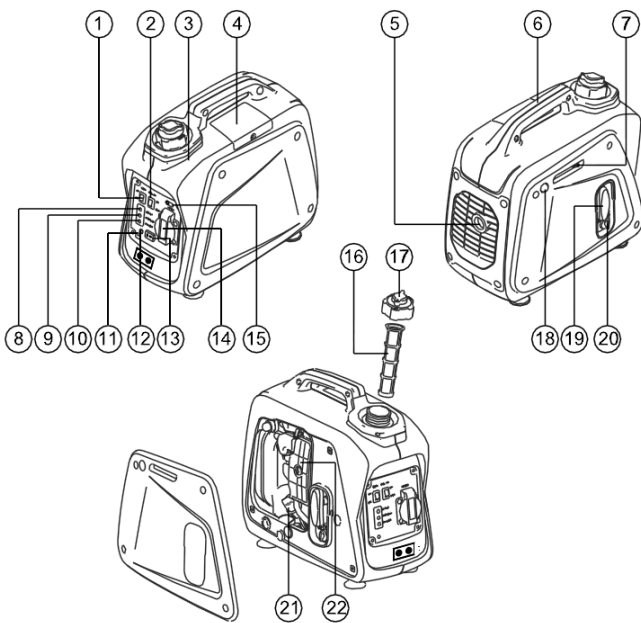

This is a Gasoline Powered Inverter Generator that offers clean power for electronics.

### 1) ENGINE SWITCH

The engine switch controls the ignition system.

To Start generator, turn POWER switch ON. Then the engine can be started by sliding Choke lever to CHOKE then pull Recoil. Allow engine to run for a few seconds then slide the Choke Lever to OFF.

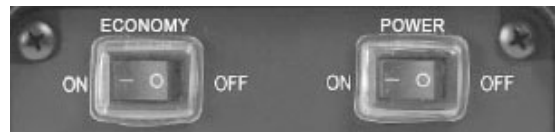

To Stop generator, press POWER switch to OFF. The engine will not run.

## 2) ECONOMY CONTROL SWITCH

When the economy control switch is turned "ON", the economy control unit controls the engine speed according to the connected load. The results are better fuel connection and less noise. (Turn OFF when using less voltage.)

## 3) LOW OIL ALERT SENSOR

When the oil level falls below the acceptable level, the engine stops automatically. Unless you refill with oil, the engine will not start again.

## 4) OVERLOAD INDICATOR LIGHT

The overload indicator light comes on when an overload of a connected electrical device is detected, the inverter unit overheats, or the AC output voltage rises. The electronic breaker will then activate, stopping power to the generation in order to protect the generator and any connected electric devices. The output pilot light will flicker GREEN, the overload indicator light will turn RED, & the engine will stop.

(a) Turn off any connected electric devices and stop the engine

(b) Reduce the total wattage of connected electric.

(c) Check for blockages in the cooling air inlet and the control unit & restart engine.

- The generator AC output automatically resets when the engine is stopped and then restarted. The overload indicator light may come on for a few seconds at first when using electric devices that require a large starting current, such as a compressor or a submersible pump. However, this is not a malfunction.

## 5) DC CIRCUIT PROTECTOR

The DC circuit protector turns off automatically when the load exceeds the generator rated output. Reduce the load to within specified generator rated output if the DC circuit protector turns off.

## 6) FUEL COCK

The fuel cock is used to supply fuel from the tank to the carburetor.

Turn ON when getting ready to start the generator. Turn OFF when finished using the generator.

### CHECK ENGINE FUEL

- Make sure there is sufficient fuel in the tank.
- If fuel is low, refill with unleaded automotive gasoline.
- Be sure to use the fuel filter screen on the fuel filter neck.
- Recommended fuel: Unleaded gasoline.
- Fuel tank capacity: 0.55 Gallon
- Do not refill tank while engine is running or hot.
- Close fuel cock before refueling with fuel.
- Be careful not to admit dust, dirt, water or other foreign objects into fuel.
- Do not fill above the top of the fuel filter or it may overflow when the fuel heats up later and expands.
- Keep open flames away.

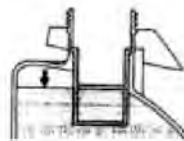



## CHECK ENGINE OIL

Remove side panel, remove oil filler cap and check the engine oil level. Make sure the engine oil is at the upper level of the oil filler hole.

- **WARNING:** The generator has been shipped without engine oil. Fill with oil or it will not start.
- Do not tilt the generator when adding engine oil. This could result in overfilling and damage to the engine
- If oil level is below the lower level line, refill with suitable oil to upper level line. Do not screw in the oil filler cap when checking oil level.
- Oil Type: SAE 10W30 Oil Capacity: 7.5 ounces

## GROUND

Ground this generator by tightening the grounding nut against a grounding wire. (See Figure 3.)

Use a No. 12 AWG (American Wire Gauge) stranded copper wire, which is generally considered an acceptable grounding wire. The other end of this grounding wire should be connected to a copper or brass grounding rod that is driven into the earth. Proper grounding of the generator will help prevent electrical shock in the event of a ground fault condition in the generator or in connected electrical devices. Proper grounding also helps dissipate static electricity, which often builds up in ungrounded devices.



Figure 3

The Grounding Terminal is located on the front of the generator, to the right of the AC Output socket.

## OPERATION

### STARTING THE ENGINE

- Before starting the engine, do not connect electric apparatus.
1. Turn the fuel cock lever to the “ON” position.
  2. Turn the fuel tank cap air vent knob clockwise to the “OPEN” position. Turn the engine switch to the “ON” or “RUN” position.
  3. Turn the choke lever to the "Close/Choke" position.
  4. PUMP the PRIMER button until the glass bowl is full.
  5. Pull the recoil starter handle slowly until resistance is felt. This is the “Compression” point. Return the handle to its original position and pull swiftly. Do not fully pull out the rope. After starting, allow the starter handle to return to its original position while still holding the handle. Grasp the carrying handle firmly to prevent the generator from falling over when pulling the recoil starter.
  6. Warm up the engine without a load for a few minutes.
  7. Turn the choke lever back to RUN position, then plug in appliances.



### USING ELECTRIC POWER

#### AC APPLICATION

- (a) Turn off the switch(es) of the electrical appliance(s) before connecting to the generator.
  - (b) Insert the plug(s) of the electrical appliance(s) into the receptacle.
- Be sure the electric apparatus is turned off before plugging in.
  - Be sure the total load is within generator rated output.
  - Be sure the socket load current is within socket rated current.
  - The economy control switch must be turned to “OFF” when using electric devices that require a large starting current, such as a compressor or a submersible pump.

## DC APPLICATION

This usage is applicable to 12V battery charging.

Be sure the Economy Control Switch is turned off while charging the battery.

## PARALLEL OUTLETS

Parallel two generators through using Parallel terminal connecting the special terminal. the parallel operating need two generators with parallel function and special cable.

- (a) Connect the special cable
- (b) Start two generators separately
- (c) The two generators running well, and green light is on, the parallel is ok. Then you can connect the device.

### NOTE:

- Turn the economic switches of two generators on or off at the same time.
- The two generator's parallel rated output is 90%of the total of two generator's rated output.
- Shut down as order. Disconnect the electric device firstly, and stop the two generators, disconnect the special cable at the end.
- Don't connect or disconnect the special cable when the generators are running.
- The parallel running is only apply to the same model with parallel function. The parallel running is only apply to the same model with parallel function.

## STOPPING THE ENGINE

Turn off the power switch of the electric apparatus or disconnect any electric devices.

Turn the POWER switch to "**STOP**" position.

Turn the fuel cock lever to "**OFF**".

Turn the fuel tank cap air vent knob counterclockwise to the "**CLOSED**" position

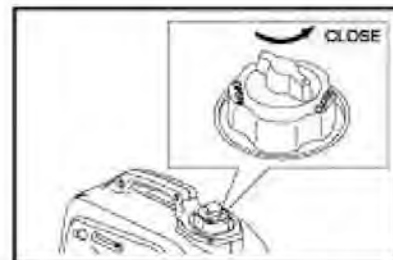
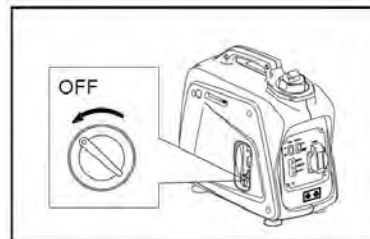

## MAINTENANCE CHART

Regular maintenance is important for the best performance and safe operation.

| Item                 | Remarks   | Pre-operation<br>Check (daily) | Initial<br>1 months<br>or 20 Hr | Every<br>3 months<br>or 50 Hr | Every<br>6 months<br>or 100 Hr | Every<br>12 months<br>or 300 Hr |
|----------------------|---|--------------------------------|---------------------------------|-------------------------------|--------------------------------|---------------------------------|
| Spark Plug           | Check condition adjust gap and clean.<br>Replace if necessary.    |                                |                                 | ●                             |                                |                                 |
| Engine Oil           | Check oil level   | ●                              |                                 |                               |                                |                                 |
|                      | Replace   |                                | ●                               |                               | ●                              |                                 |
| Oil filter           | Clean oil filter  |                                |                                 |                               | ●                              |                                 |
| Air Filter           | Clean. Replace if necessary.                                      |                                |                                 | ●                             |                                |                                 |
| Fuel Filter          | Clean fuel cock filter. Replace if<br>necessary                   |                                |                                 |                               | ●                              |                                 |
| Choke                | Check choke operation   | ●                              |                                 |                               |                                |                                 |
| Valve Clearance      | Check and adjust when engine is cold.                             |                                |                                 |                               |                                | ●                               |
| Fuel Line            | Check fuel hose for crack or damage.<br>Replace if necessary.     | ●                              |                                 |                               |                                |                                 |
| Exhaust System       | Check for leakage. Retighten or<br>replace gasket if necessary    | ●                              |                                 |                               |                                |                                 |
|                      | Check muffler screen.<br><br>Clean / replace if necessary.        |                                |                                 |                               |                                | ●                               |
| Carburetor           | Check choke operation   | ●                              |                                 |                               |                                |                                 |
| Cooling system       | Check fan damage.   |                                |                                 |                               |                                | ●                               |
| Starting system      | Check recoil starter operation.                                   | ●                              |                                 |                               |                                |                                 |
| Idle speed           | Check and adjust engine idle speed                                |                                |                                 |                               |                                | ●                               |
| Fittings / Fasteners | Check all fittings and fasteners correct<br>if necessary.         |                                |                                 |                               | ●                              |                                 |
| Crankcase breather   | Check breather hose for cracks or<br>damage. Replace if necessary |                                |                                 |                               |                                | ●                               |
| Generator            | Check the pilot light comes on                                    | ●                              |                                 |                               |                                |                                 |

## ENGINE OIL REPLACEMENT

1. Place the machine on a level surface and warm up the engine for several minutes. Then stop the engine and turn the fuel cock knob to "OFF". Turn the fuel tank cap air vent knob clockwise.

2. Loosen the screw and remove the cover.

3. Remove the oil filler cap

4. Place an oil pan under the engine.  
Tilt the generator to drain the oil completely

5. Replace the generator on a level surface.

6. Add engine oil to the upper level.

7. Install the oil filler cap

8. Install the cover and tighten the screw

- Engine Oil SAE 10W30 Capacity: 7.5 oz.

- Be sure no foreign material enters the crankcase.

- Do not tilt the generator when adding engine oil. This could result in overfilling and damage to the engine

- Clean the oil filter every other 100 hr.

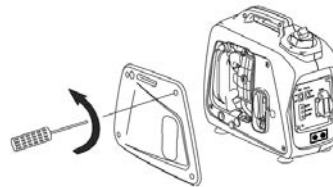
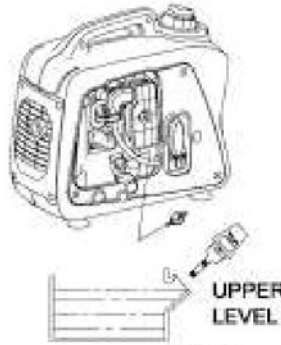

## WASHABLE AIR FILTER

Maintaining an air cleaner in proper condition is very important. Dirt induced through improperly installed, improperly serviced, or inadequate elements damages and wears out engines. Keep the element always clean.

1. Remove the cover.

2. Remove the air filter cover and element.

3. Wash the element in solvent and dry.

4. Oil the element and squeeze out excess oil. The element should be wet but not dripping.

5. Insert the element into the air filter.

6. Install the cover.

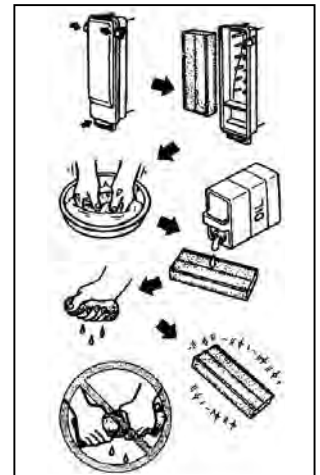

The engine should never run without the Filter; excessive piston and/or cylinder wear may result.

## CLEANING AND ADJUSTING SPARK PLUG

1. Remove the cover.

2. Check for discoloration and remove the carbon.

3. Check the spark plug type and gap.

Standard Spark Plug: CMR6A

Spark Plug Gap: 0.6-0.7 mm (0.024-0.028 in)

4. Install the spark plug.

5. Install the cover

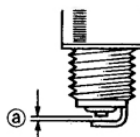

## FUEL TANK FILTER

1. Remove the fuel tank cap and filter.
  2. Clean the filter with solvent. If damaged, replace.
  3. Wipe the filter and insert it.
- Be sure the tank cap is tightened securely.

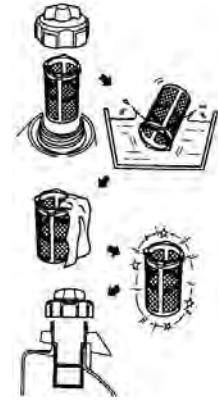

## MUFFLER SCREEN

- The engine and muffler will be very hot after the engine has been run.
- Avoid touching the engine and muffler while they are still hot with any part of your body or clothing during inspection or repair.

1. Remove the cover.
2. Remove the muffler screen.
3. Use the flathead screw driver to pry the spark arrester out from the muffler
4. Remove the carbon deposits on the muffler screen and spark arrester using a wire brush.
5. Install the muffler screen.
6. Install the cover

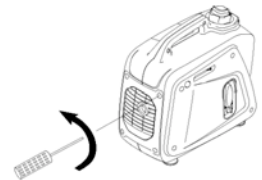

## TROUBLE SHOOTING

### Engine won't start

#### 1. Fuel systems

No fuel supplied to combustion chamber.

- No fuel in tank....Supply fuel.
- Fuel in tank....Fuel tank cap air vent knob to **"OPEN"**, fuel cock knob to **"OPEN"**.
- Clogged fuel line....Clean fuel line.
- Clogged carburetor....Clean carburetor.

#### Engine oil system

Insufficient

- Oil level is low....Add engine oil.

#### Electrical systems

Poor spark

- Spark plug dirty with carbon or wet....Remove carbon or wipe spark plug dry.

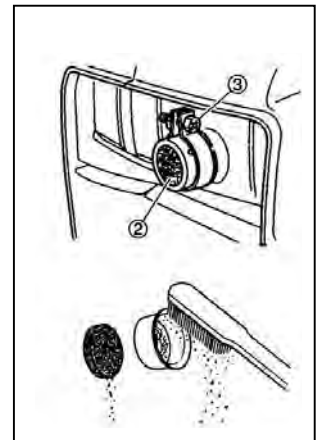

- Faulty ignition system....Consult dealer.

Compression insufficient

- Worn out piston and cylinder....Consult dealer.

**Generator won't produce power**

Safety device (AC) to "OFF" ...Stop the engine, then restart.

Safety device (DC) to "OFF" ...Press to reset the DC protector

**STORAGE**

Long term storage of your machine will require some preventive procedures to guard against deterioration.

**1) DRAIN THE FUEL**

1. Remove the fuel tank cap, drain the fuel from the fuel tank.
2. Remove the cover, drain fuel from the carburetor by loosening the carb hose.

**2) ENGINE**

1. Remove the spark plug, pour in about one tablespoon of SAE 10W30 motor oil into the spark plug hole and reinstall the spark plug.
2. Use the recoil starter to turn the engine over several times (with ignition off).
3. Pull the recoil starter until you feel compression.
4. Stop pulling.
5. Clean exterior of the generator and apply a rust inhibitor.
6. Store the generator in a dry, well-ventilated place, with the cover place over it.
7. The generator must remain in a vertical position.

**SPECIFICATION**

|                  |              |                    |      |
|------------------|--------------|--------------------|------|
| <b>MODEL</b>     |              | <b>GEN1000I-PL</b> |      |
| <b>GENERATOR</b> | Type         | Invertor Generator |      |
|                  | AC Voltage   |                    |      |
|                  |              | 60Hz               | 120V |
|                  | Max. Output  | 1.00 kVA           |      |
|                  | Rated Output | 0.80 kVA           |      |
|                  | Power Factor | 1.0                |      |
| DC Output        | 12V / 4.0A   |                    |      |

|                  |                                |   |
|------------------|--------------------------------|---|
| <b>ENGINE</b>    | Model                          | XY139F-6                                  |
|                  | Type                           | Air-cooled, 4 cycle, OHV, Gasoline Engine |
|                  | Bore × Stroke    mm × mm       | 39 × 33.5                                 |
|                  | Displacement                   | 40 cc                                     |
|                  | Max. Output                    | 0.9KW / 5500rpm                           |
|                  | Fuel                           | Regular Automobile Gasoline               |
|                  | Fuel tank Capacity             | 0.55 Gallon                               |
|                  | Rated Continuous Operation     | 6.3 hr @ 50% load                         |
|                  | Lubricating oil                | SAE 10W30                                 |
|                  | Lubricating oil Capacity       | 7.5 ounce                                 |
|                  | Starting System                | Recoil Starter                            |
|                  | Ignition system                | C.D.I.                                    |
|                  | Spark Plug: Type               | CMR6A (TORCH)                             |
| <b>DIMENSION</b> | Net dimension    L × W × H     | 395 × 209 × 355                           |
|                  | Overall dimension    L × W × H | 425 × 230 × 380                           |
|                  | Net Weight                     | 9.2 Kg                                    |
|                  | Gross Weight                   | 11.4Kg                                    |

- Specifications subject to change without prior notice.

- High Altitude Use: This generator is not recommended for high altitude use above 3,000 feet.

## **STORAGE INSTRUCTIONS**

Long term storage of your machine will require some preventive procedures to guard against deterioration.

### **1. DRAIN THE FUEL**

Remove the fuel tank cap, drain the fuel from the fuel tank

### **2. ENGINE**

Remove spark plug, pour in about one tablespoon of SAE 10W30 motor oil into the spark plug hole and reinstall spark plug. Use the recoil starter to turn the engine over several times (with ignition off).

Pull the recoil starter until you feel compression.

Stop pulling.

Clean exterior of the generator and apply a rust inhibitor.

Store the generator in a dry, well-ventilated place, with the cover place over it.

The generator must remain in a vertical position



# WIRING DIAGRAM

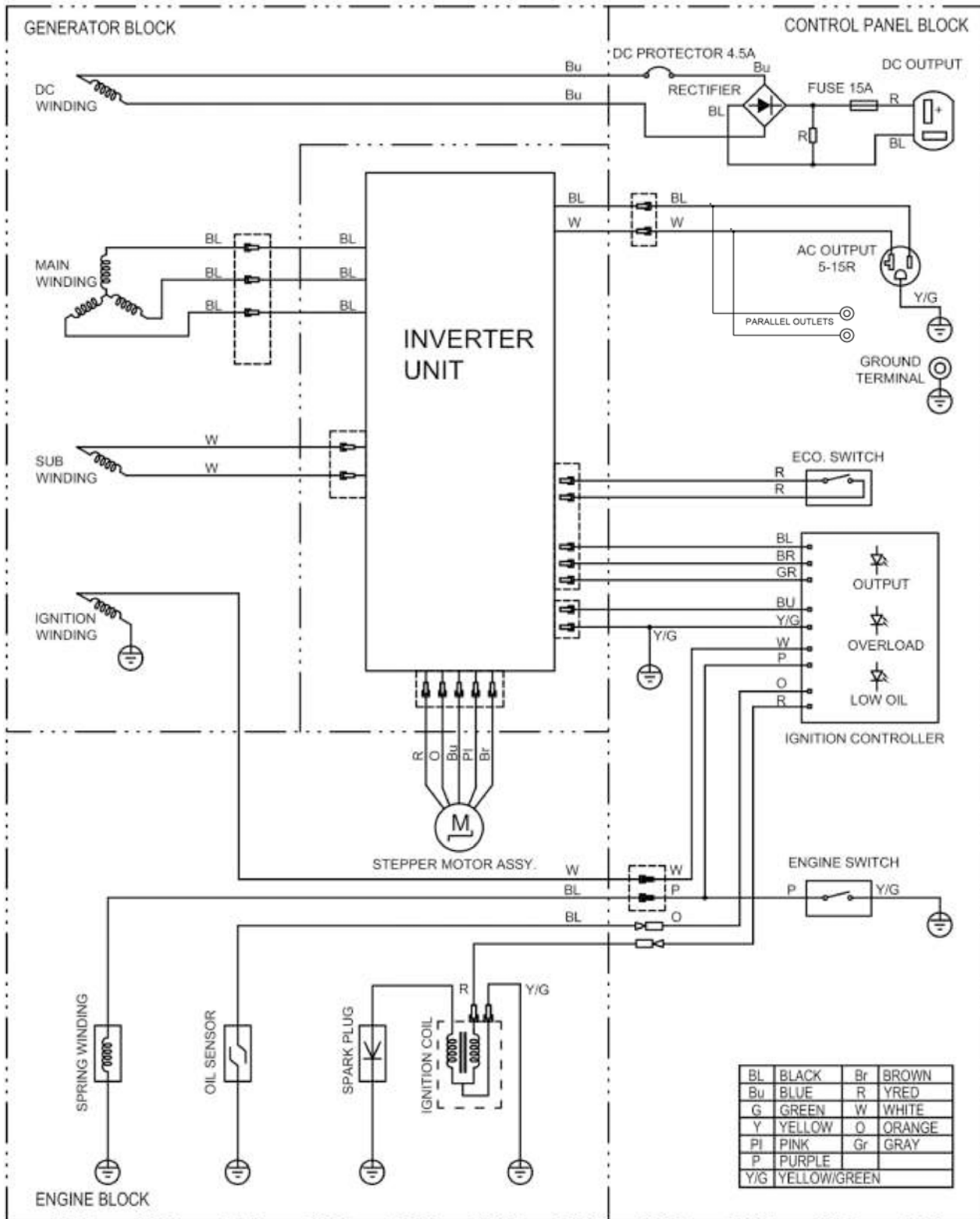

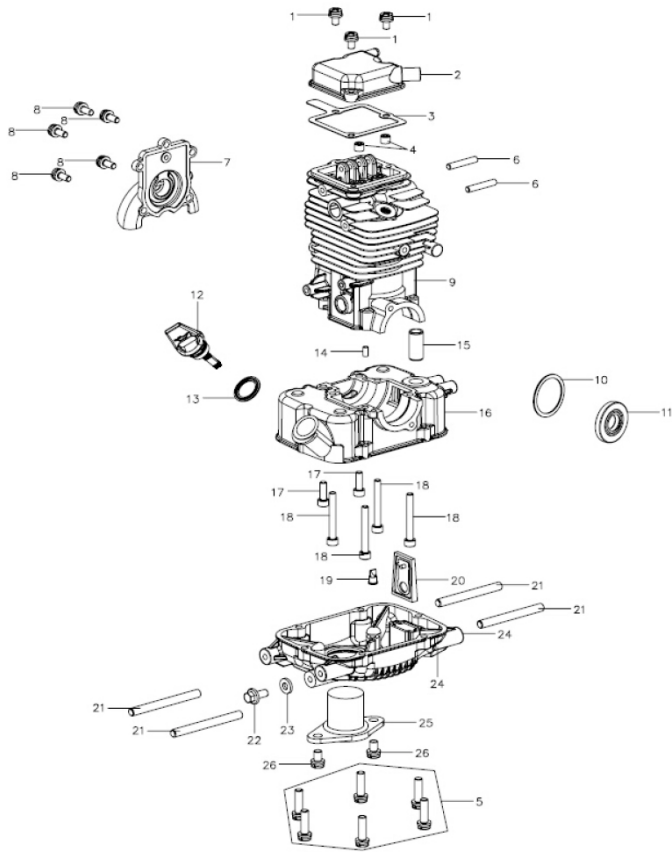

**FIG. A CRANKCASE ASSY**

| No. | Part No.       | Description               | Qty |
|-----|----------------|---------------------------|-----|
| 1   | 00252000502011 | Screw M5×20               | 3   |
| 2   | 14760100001001 | Cylinder Head Cover       | 1   |
| 3   | 14760100002011 | Cylinder Head Cover Seal  | 1   |
| 4   | 14760101001001 | Valve Oil Seal            | 2   |
| 5   | 00252000502511 | Dual-Head Bolts M5×70     | 6   |
| 6   | 14760100005041 | Dual-Head Bolts M5×28     | 2   |
| 7   | 14760100003001 | Cam Chamber Cover         | 1   |
| 8   | 00252000501411 | Screw M5×14               | 5   |
| 9   | 14810101000101 | Upper Crankcase           | 1   |
| 10  | 14770100004041 | Washer 30×37×1            | 1   |
| 11  | 14760100007102 | Oil Seal 15×35×5          | 1   |
| 12  | 14760102101003 | Oil Gauge                 | 1   |
| 13  | 14760102102101 | Oil Gauge Gasket          | 1   |
| 14  | 00510000400801 | Dowel Pin 4×8             | 1   |
| 15  | 14760102003001 | Ventilation Nozzle        | 1   |
| 16  | 14760102001001 | Lower Crankcase           | 1   |
| 17  | 00204000501641 | Screw M5×16               | 2   |
| 18  | 00204000504041 | Screw M5×40               | 4   |
| 19  | 14760102002101 | Rubber One-Way Valve      | 1   |
| 20  | 14760501000001 | One-Way Valve Components  | 1   |
| 21  | 14760103003011 | Dual-Head Bolts M6×36     | 4   |
| 22  | 00031000601212 | Hexagon Flange Bolt M6×12 | 1   |
| 23  | 14760103002031 | Aluminium Gasket 6×13×2   | 1   |
| 24  | 14760103001001 | Oil Pan                   | 1   |
| 25  | 14620103100002 | Oil Level Sensor          | 1   |
| 26  | 00252000601811 | Screw M6×18               | 2   |

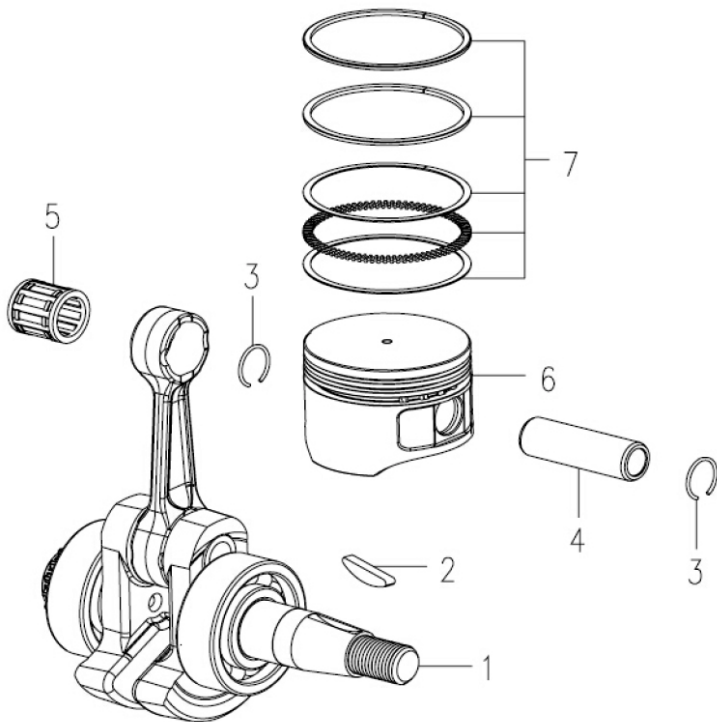

**FIG B. CRANKSHAFT PISTON**

| No. | Part No.       | Description            | Qty |
|-----|----------------|------------------------|-----|
| 1   | 14760302000001 | Connecting Rod         | 1   |
| 2   | 11310300010001 | Woodruff Key           | 1   |
| 3   | 14760300001002 | Piston Pin Clip        | 2   |
| 4   | 14760300002002 | Piston Pin             | 1   |
| 5   | 00833710141402 | Needle Bearing K101414 | 1   |
| 6   | 14810301001001 | Piston                 | 1   |
| 7   | 14780301006001 | Piston Ring            | 1   |

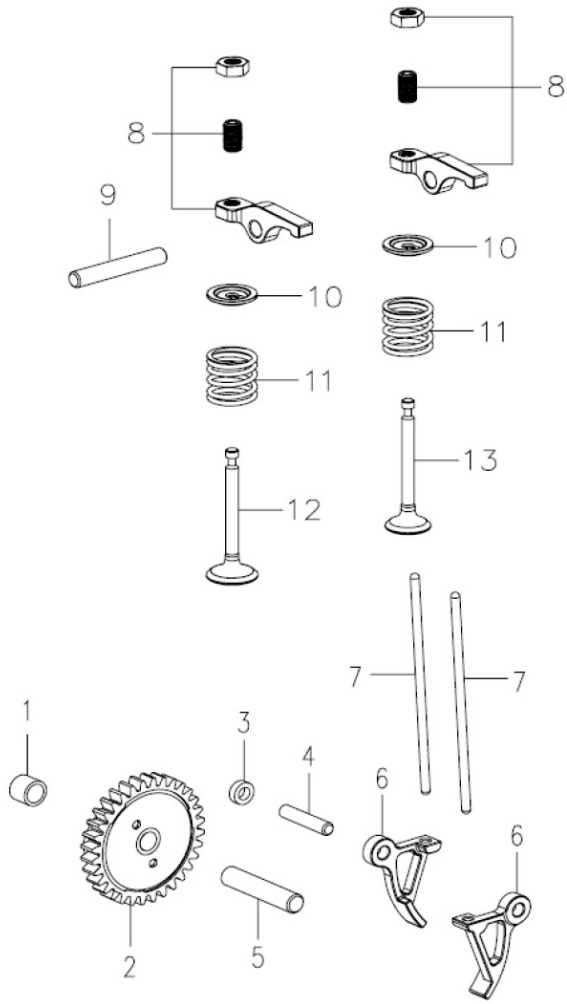

**FIG C. CAMSHAFT**

| No. | Part No.       | Description              | Qty |
|-----|----------------|--------------------------|-----|
| 1   | 14760100006001 | Dowel Bush               | 1   |
| 2   | 14760401100012 | Camshaft                 | 1   |
|     | 14760401001002 | Decompression of the pin | 1   |
|     | 14760401002102 | Torsional spring         | 1   |
|     | 14760401003002 | Cover for cam            | 1   |
| 3   | 14760400010041 | Rocker Gasket            | 1   |
| 4   | 00504000402003 | Pin4 g4×20               | 1   |
| 5   | 00504000603003 | Pin4 g6×30               | 1   |
| 6   | 14760400006002 | Lower Rocker             | 2   |
| 7   | 14760400009002 | Tappet                   | 2   |
| 8   | 14760400005002 | Upper Rocker             | 2   |
| 9   | 00504000503203 | Pin 5 g6×32              | 1   |
| 10  | 14760400003002 | Valve Spring Seat        | 2   |
| 11  | 14760400004002 | Valve Spring             | 2   |
| 12  | 14760400001003 | Intake Valve             | 1   |
| 13  | 14760400002003 | Exhaust Valve            | 1   |

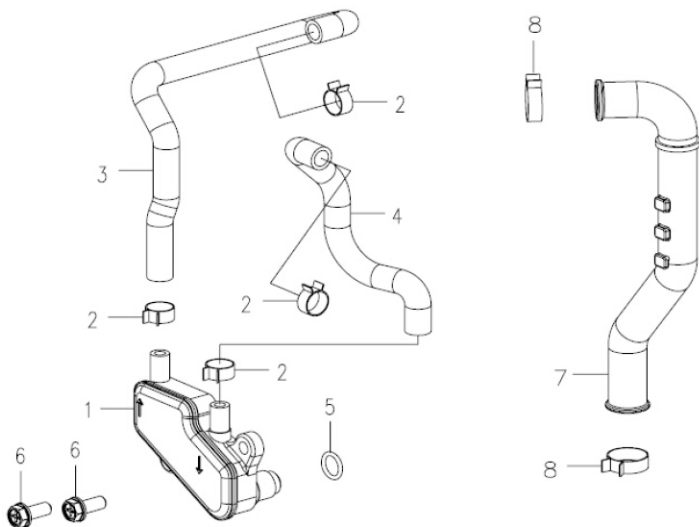

**FIG D. LUBRICATION SYSTEM**

| No. | Part No.       | Description               | Qty |
|-----|----------------|---------------------------|-----|
| 1   | 14760502000101 | Deaerator                 | 1   |
| 2   | 14760500005001 | Pipe Hoop 9               | 4   |
| 3   | 14610500002001 | Respiratory Tube          | 1   |
| 4   | 14610500003001 | Outlet Tube               | 1   |
| 5   | 14760500004003 | O Ring                    | 1   |
| 6   | 00031000501612 | Hexagon Flange Bolt M5×16 | 2   |
| 7   | 14610500001001 | Upper Oil Pipe            | 1   |
| 8   | 11311600006002 | Pipe Hoop 13              | 2   |

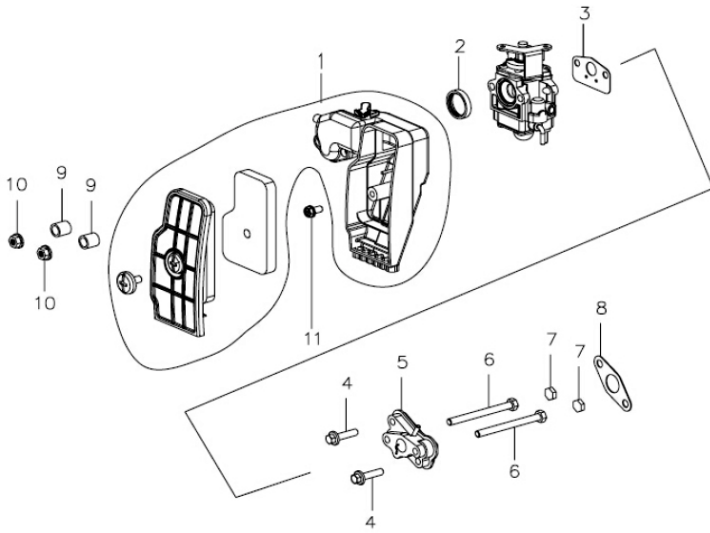

**FIG E. AIR CLEANER**

| No. | Part No.       | Description                  | Qty |
|-----|----------------|------------------------------|-----|
| 1   | 14760801000002 | Air Filter                   | 1   |
|     | 14760801003002 | Foam                         | 1   |
|     | 14760801007021 | big head chrome plated Screw | 1   |
| 2   | 14760800004001 | Gasket of Air Filter         | 1   |
| 3   | 14780800003002 | Gasket of Carburator         | 1   |
| 4   | 00033000502211 | Hexagon Flange Bolts M5×22   | 2   |
| 5   | 14810800002001 | Insulation Board Components  | 1   |
| 6   | 00026000505551 | Hexagon Flange Bolts M5×55   | 2   |
| 7   | 14810800003001 | Block rubber                 | 2   |
| 8   | 14810800001012 | Insulation Board Gasket      | 1   |
| 9   | 15561100004002 | Fan Volute Bush              | 2   |
| 10  | 00129000500011 | Hexagon Flange Bolts M5      | 2   |
| 11  | 00427014801641 | Tap Screw ST4.8×16-F.H       | 1   |

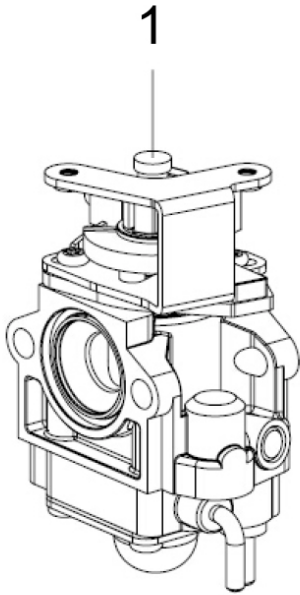

**FIG.F CARBURETOR**

| No. | Part No.       | Description | Qty |
|-----|----------------|-------------|-----|
| 1   | 14760901000001 | Carburator  | 1   |

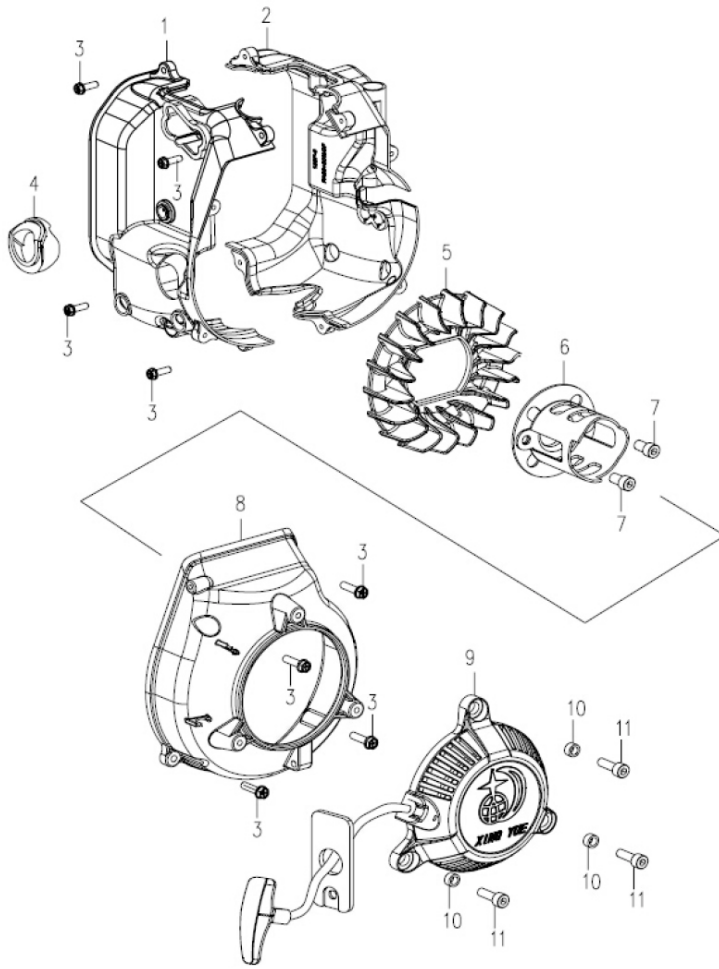

**FIG G. RECOIL STARTER**

| No. | Part No.       | Description                  | Qty |
|-----|----------------|------------------------------|-----|
| 1   | 14811100001001 | Air Guide Sleeve A           | 1   |
| 2   | 14761100014001 | Air Guide Sleeve B           | 1   |
| 3   | 00427014801641 | Tap Screw ST4.8×16           | 8   |
| 4   | 14611100006002 | Oil Filler Hole Airproof Pad | 1   |
| 5   | 14761100001002 | Cooling Fan                  | 1   |
| 6   | 14760602000001 | Starting Hub                 | 1   |
| 7   | 00204000601041 | Inner Hexagon Screw M6×10    | 2   |
| 8   | 14761100002002 | Fan Volute                   | 1   |
| 9   | 14760601000002 | Recoil Starter               | 1   |
|     | 15560602001101 | Handle                       | 1   |
|     | 15560602003001 | Fender                       | 1   |
| 10  | 15600600002003 | Recoil Starter Bush          | 3   |
| 11  | 00031000501611 | Hexagon Flange Bolts M5×16   | 3   |

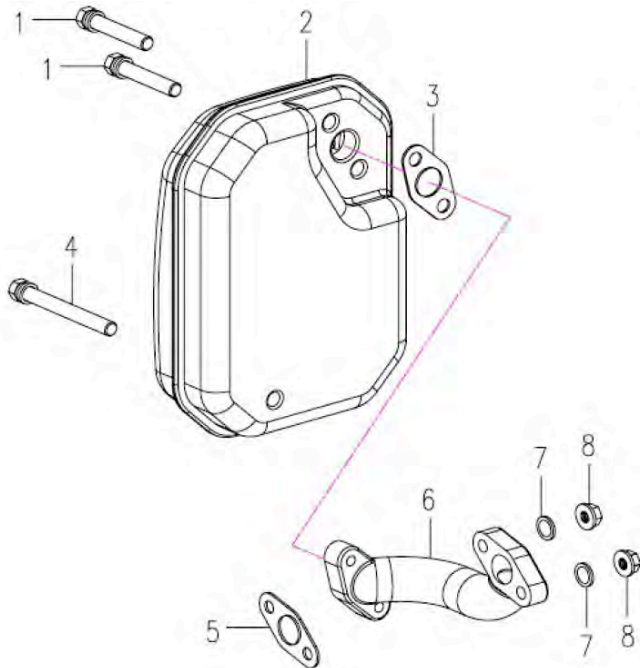

**FIG H. MUFFLER**

| No. | Part No.       | Description           | Qty |
|-----|----------------|-----------------------|-----|
| 1   | 00722000603511 | Bolt M6×35            | 2   |
| 2   | 14760701000001 | Muffler               | 1   |
| 3   | 14760700001011 | Muffler Pipe Gasket   | 1   |
| 4   | 00722000605511 | Bolt M6×55            | 1   |
| 5   | 14760700003011 | Muffler Gasket        | 1   |
| 6   | 14760700002003 | Muffler Pipe          | 1   |
| 7   | 00030000500041 | Washer 5              | 2   |
| 8   | 00101000500011 | Hexagon Flange Nut M5 | 2   |

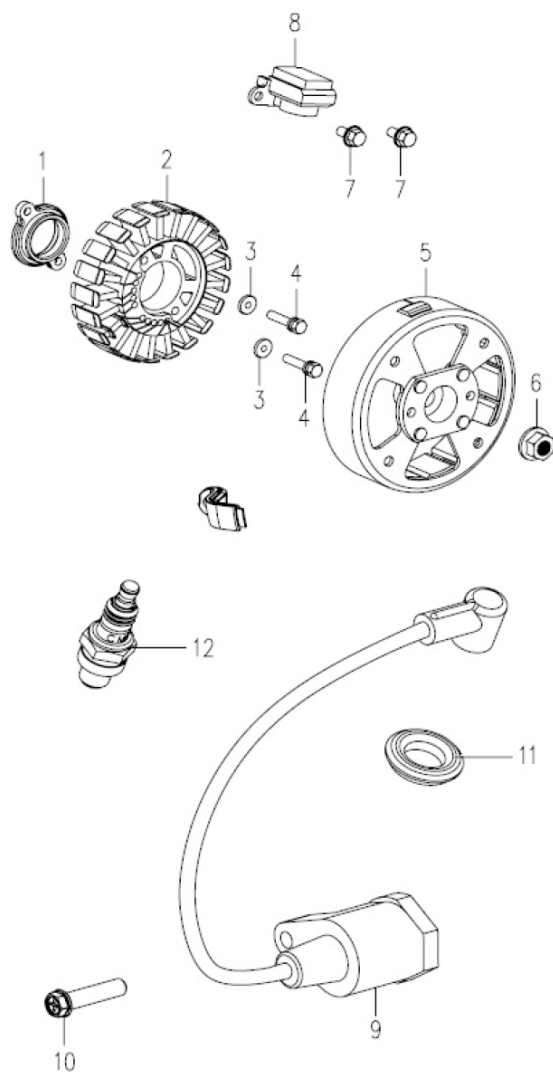

**FIG I. GENERATOR**

| No. | Part No.       | Description                 | Qty |
|-----|----------------|-----------------------------|-----|
| 1   | 14761000001001 | Locating Plate              | 1   |
| 2   | 14761001101101 | Stator 0.8KW 230V 580Hz     | 1   |
|     | 14761000002002 | Bushing                     | 1   |
| 3   | 00030000500041 | Washer 5                    | 1   |
| 4   | 00033000502211 | Hexagon Flange Bolts M5×35  | 2   |
| 5   | 14761001200101 | Rotor                       | 1   |
| 6   | 00129001000032 | Hexagon Flange Nut M10×1.25 | 1   |
| 7   | 00033000501001 | Hexagon Flange Bolts M5×10  | 2   |
| 8   | 14761000004002 | Trigger                     | 1   |
| 9   | 14761003000101 | Ignition Coil               | 1   |
| 10  | 00241004802541 | Tap Screw ST4.8×25-F.H      | 1   |
| 11  | 14761000003001 | Ignition Coil Cap Seal      | 1   |
| 12  | 14761002000001 | Spark Plug CMR6A            | 1   |

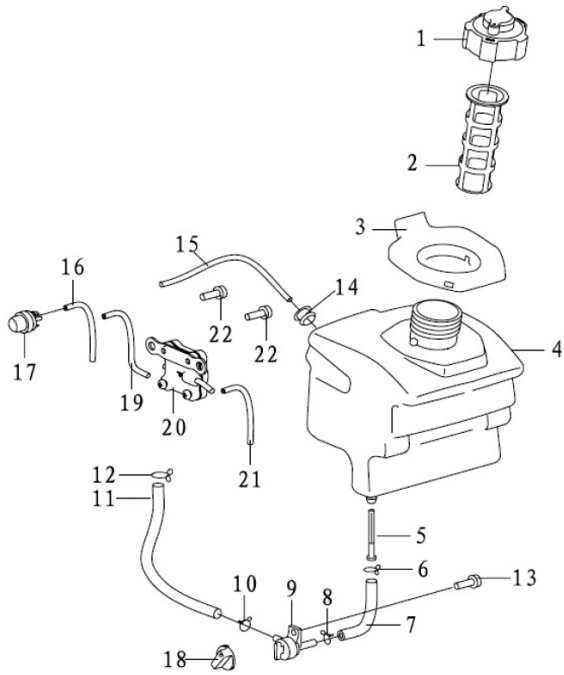
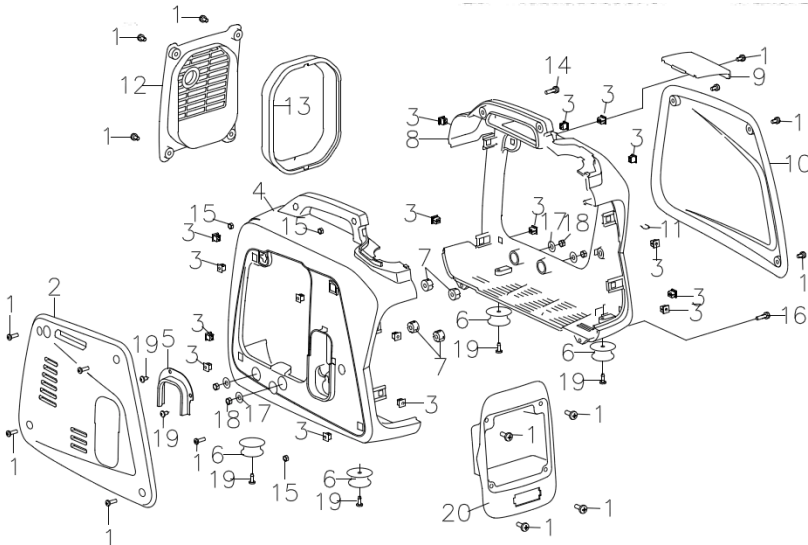

**FIG J. FUEL TANK(EPA)**

| No. | Part No.     | Description                       | Qty |
|-----|--------------|-----------------------------------|-----|
| 1   | 462405010000 | Fuel Tank Cap Assy.               | 1   |
| 2   | 462405020000 | Fuel Tank Filter                  | 1   |
| 3   | 460703000080 | Fuel Tank Port Rubber             | 1   |
| 4   | 460705010011 | Fuel Tank (EPA)                   | 1   |
| 5   | 462405030000 | Fuel Outlet Filter                | 1   |
| 6   | 480202020110 | Steel Wire Clamp $\varnothing$ 11 | 1   |
| 7   | 460705000011 | Fuel Hose(EPA)                    | 1   |
| 8   | 480202020100 | Steel Wire Clamp $\varnothing$ 10 | 1   |
| 9   | 460705020000 | Fuel Cock                         | 1   |
| 10  | 480202010090 | Steel Wire Clamp $\varnothing$ 9  | 1   |
| 11  | 460705000021 | Fuel Hose 4.5×7.5×180(EPA)        | 1   |
| 12  | 480202010080 | Steel Wire Clamp $\varnothing$ 8  | 1   |
| 13  | 004210148013 | Tap Screw GB/T845 ST4.8×13-F      | 1   |
| 14  | 460705010020 | Fuel-hole Plug                    | 1   |
| 15  | 480201250511 | Fuel Hose 2.5×5×120(EPA)          | 1   |
| 16  | 480201250511 | Fuel Hose 2.5×5×80(EPA)           | 1   |
| 17  | 460705040000 | Fuel Lubricator                   | 1   |
| 18  | 460705010040 | Fuel Cock Knob                    | 1   |
| 19  | 480201250511 | Fuel Hose 2.5×5×95(EPA)           | 1   |
| 20  | 460705050000 | negative pressure pump            | 1   |
| 21  | 480201250511 | Fuel Hose 2.5×5×110(EPA)          | 1   |
| 22  | 004210348095 | Tap Screw GB/T845 ST4.8×9.5-F     | 2   |

**FIG K. SHELL**

| No. | Part No.     | Description                        | Qty |
|-----|--------------|------------------------------------|-----|
| 1   | 004210148013 | Screw 4.8×13-F                     | 18  |
| 2   | 460703000050 | Right Side Cover                   | 1   |
| 3   | 460703000110 | Fastener                           | 17  |
| 4   | 460703000040 | Right Cover of Shell               | 1   |
| 5   | 460703000061 | Edge Protection                    | 1   |
| 6   | 460703000140 | Vibration Absorber                 | 4   |
| 7   | 460703000120 | Rubber Pad $\Phi$ 6× $\Phi$ 16×10  | 4   |
| 8   | 460703000010 | Left Cover of Shell                | 1   |
| 9   | 460703000030 | Upper Cover                        | 1   |
| 10  | 460703000020 | Left Side Cover                    | 1   |
| 11  | 461503000080 | Clamp                              | 1   |
| 12  | 460703000090 | Muffler Cover                      | 1   |
| 13  | 460703000100 | Muffler Cover Seal                 | 1   |
| 14  | 007090005018 | Screw GB/T9074.4 M5×18             | 2   |
| 15  | 001200005001 | Hexagon Nut M5                     | 4   |
| 16  | 002260005016 | Cross Pan Head Screw M5×16         | 2   |
| 17  | 460703000130 | Rubber Pad $\Phi$ 6.5× $\Phi$ 16×2 | 4   |
| 18  | 001410006001 | Lock Nut GB/T6187 M6               | 4   |
| 19  | 004210348095 | Tap Screw GB/T845 ST4.8×9.5-F      | 6   |
| 20  | 460703000070 | Panel Box                          | 1   |



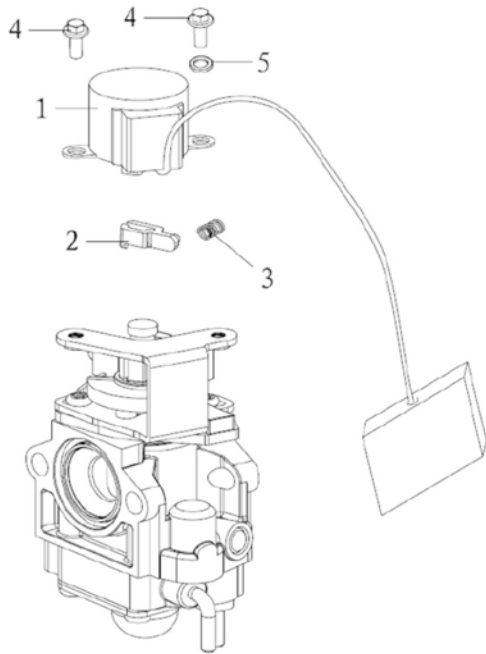

**FIG L. GOVERNOR**

| No. | Part No.     | Description      | Qty |
|-----|--------------|------------------|-----|
| 1   | 460720020000 | Stepper Motor    | 1   |
| 2   | 155609000020 | Drive Arm        | 1   |
| 3   | 155609000010 | Drive Arm Spring | 1   |
| 4   | 007080004006 | Screw M4×6       | 2   |
| 5   | 003000004001 | Spring Washer 4  | 1   |

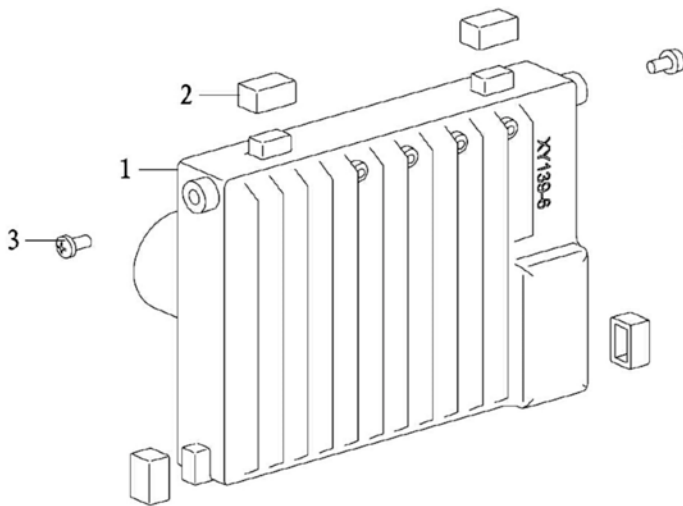

**FIG M. INVERTER**

| No. | Part No.     | Description                 | Qty |
|-----|--------------|-----------------------------|-----|
| 1   | 460719010000 | Inverter 0.8Kw 120V~60Hz    | 1   |
|     | 460719010000 | Inverter 0.8Kw 100V~50/60Hz | 1   |
| 2   | 460719000010 | Inverter Gasket             | 4   |
| 3   | 007090005012 | Screw GB/T9074.4 M5×12      | 2   |



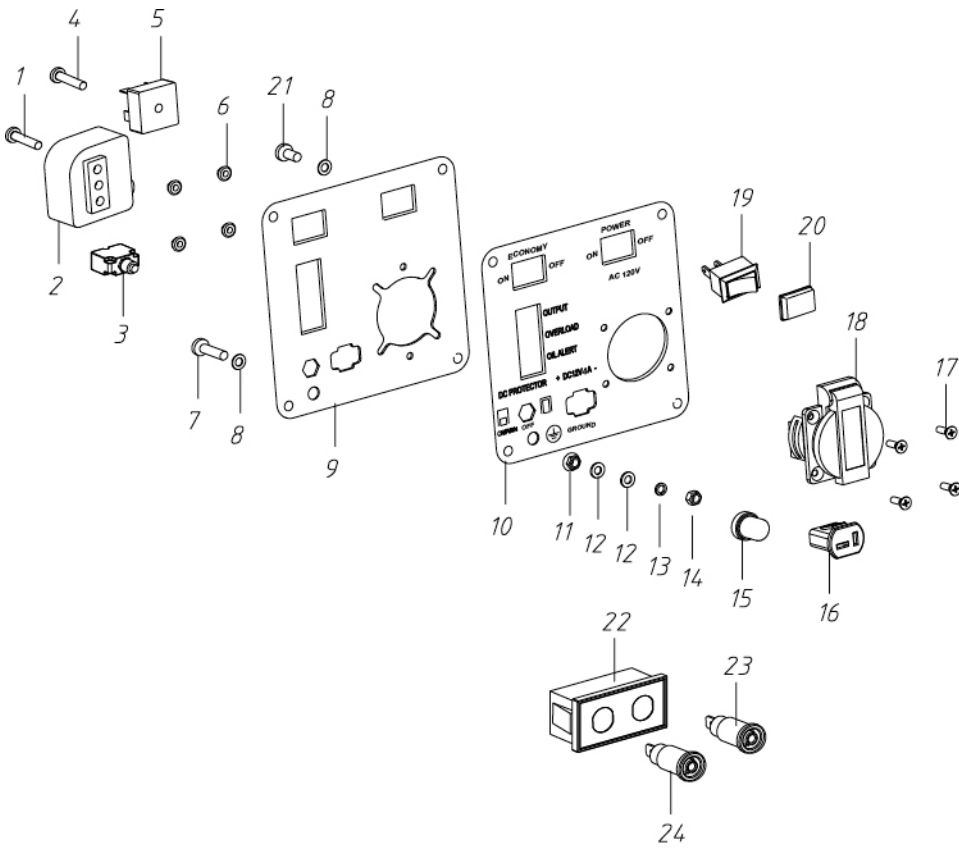

**FIG N. CONTROL PANEL (FOR USA)**

| No. | Part No.     | Description                      | Qty |
|-----|--------------|----------------------------------|-----|
| 1   | 007090005016 | Cross Pan Head Screw M5×16       | 1   |
| 2   | 462417016000 | Ignition Control Module          | 1   |
| 3   | 480107881450 | Overload Protector 4.5A          | 1   |
| 4   | 007080005016 | Cross Pan Head Screw M5×16       | 1   |
| 5   | 480110350200 | Rectifier KBPC3502               | 1   |
| 6   | 001280004001 | Hexagon Flange Nut M4            | 4   |
| 7   | 000330005016 | Flange Bolt GB/16674 M5×16       | 1   |
| 8   | 003210005001 | Lock Gasket GB862.2 φ5           | 3   |
| 9   | 460717011000 | Panel Components                 | 1   |
| 10  | 460788000030 | Panel Sticker                    | 1   |
| 11  | 001280005001 | Flange Nut GB/T6177 M5           | 1   |
| 12  | 003020005001 | Flat Washer GB/T97 φ5            | 2   |
| 13  | 003000005001 | Spring Washer GB/T93 φ5          | 1   |
| 14  | 001200005001 | Hexagon Nut GB/T6170 M5          | 1   |
| 15  | 480107000020 | Water-Proof Cap of Protector     | 1   |
| 16  | 480101090030 | DC Charging Socket               | 1   |
| 17  | 002210004012 | Countersunk Head Screw M4×12     | 4   |
| 18  | 480101020040 | American Socket 5-15R            | 1   |
| 19  | 480105010010 | Boat Switch                      | 2   |
| 20  | 480105090010 | Water-Proof Cap of Boat Switch   | 2   |
| 21  | 007090005008 | Screw M5×8                       | 2   |
| 22  | 460703000170 | Parallel Output Box              | 1   |
| 23  | 480101100010 | Parallel Connection Port (Red)   | 1   |
| 24  | 480101100020 | Parallel Connection Port (Black) | 1   |

## **EMISSION CONTROL SYSTEM WARRANTY BUFFALO CORPORATION**

### Your Warranty Rights and Obligations

The California Air Resources Board, U.S. EPA and Buffalo Corp are pleased to explain the Emission Control System Warranty on your 2018 model year outdoor power equipment engine.

#### California

In California, new spark-ignited small off-stringent anti-smog standards.

#### Other States, U.S. Territories

In other areas of the United States, your engine must be designed, built and equipped to meet the U.S. EPA emission standards for spark-ignited engines at or below 19 kilowatts.

#### All of the United States

Buffalo Corp must warrant the emission control system on your power equipment engine for the periods of time listed below provided there has been no abuse, neglect or improper maintenance of your power equipment engine. Where a warrantable condition exists, Buffalo Corp will repair your power equipment engine at no cost to you including diagnosis, parts and labor.

Your emission control system may include parts such as: carburetors or fuel injection system, ignition system, catalytic converters, fuel tanks, valves, filters, clamps, connectors, and other associated components. Also, included may be hoses, belts, connectors, sensors, and other emission-related assemblies.

#### Manufacturer's Warranty Coverage

The emission control system is warranted for two years. If any emissions-related part on your engine is defective, the part will be repaired or replaced by Buffalo Corp.

#### Owner's Warranty Responsibility

As the power equipment engine owner, you are responsible for the performance of the required maintenance listed in your owner's manual. Buffalo Corp recommends that you retain all receipts covering maintenance on your power equipment engine, but Buffalo Corp cannot deny warranty solely for the lack of receipts or for your failure to ensure the performance of all scheduled maintenance. As the power equipment engine owner, you should however be aware that Buffalo Corp may deny your warranty coverage if your power equipment engine or a part has failed due to abuse, neglect, improper maintenance or unapproved modifications. You are responsible for presenting your power equipment engine to distribution center or service center authorized by Buffalo Corp as soon as the problem exists. The warranty repairs should be completed in a reasonable amount of time, not to exceed 30 days. If you have any questions regarding your warranty rights and responsibilities, you should contact a customer service representative at 1-866-460-9436 or email [info@buffalotools.com](mailto:info@buffalotools.com)

#### DEFECTS Warranty Coverage

Adopted by the Air Resources Board, Buffalo Corp warrants to the ultimate purchaser and each subsequent purchaser that the small off-road engine (SORE) (1) has been designed, built and equipped so as to conform with all applicable regulation; and (2) is free from defects in materials and workmanship that cause the failure of a warranted part to conform with those regulations as may be applicable to the terms and conditions stated below. (a) The warranty period begins on the date the engines is delivered to an ultimate purchaser or first placed into service. The warranty period is two years. (b) Subject to certain conditions and exclusions as stated below, the warranty on emissions related parts is as follows:

(1) Any warranted part that is not scheduled for replacement as required maintenance in your Owner's Manual is warranted for the warranty period stated above. If the part fails during the period of warranty coverage, the part will be repaired or replaced by Buffalo Corp according to Subsection (4) below. Any such part repaired or replaced under warranty will be warranted for the remainder of the period.

- (2) Any warranty part that is scheduled only for regular inspection in your period stated above. Any such part repaired or replaced under warranty will be warranted for the remaining warranty period.
- (3) Any warranted part that is scheduled for replacement as required maintenance in your Owners Manual is warranted for the period of time before the first scheduled replacement date for that part. If the part fails before the first scheduled replacement, the part will be repaired or replaced by Buffalo Corp. according to the Subject (4) below. Any such part repaired or replaced under warranty will be warranted for the remainder of the period prior to the first scheduled replacement point for the part.
- (4) Repair or replacement of any warranted part under the warranty provisions herein must be performed at a warranty station at no charge to the owner.
- (5) Notwithstanding the provisions herein, warranty services or repair will be provided at all of our distribution centers that are franchised to service the subject engines.
- (6) The engine owner must not be charged for diagnostic labor that leads to the determination that a warranted part is in fact defective, provided that such diagnostic work is performed at a warranty station.
- (7) Buffalo Corp. is liable for damages to other engine components proximately caused by a failure under warranty of any warranted part.
- (8) Throughout the engine warranty period stated above, Buffalo Corp. will maintain a supply of warranted parts sufficient to meet the expected demand for such parts.
- (9) Any replacement part may be used in the performance of any warranty maintenance or repairs and must be provided without charge to the owner. Such use will not reduce the warranty obligations of Buffalo Corp.
- (10) Add-on or modified parts that are not exempted by the Air Resources Board may not be used. The use of any non-exempted add-on or modified parts by the ultimate purchaser will be grounds for disallowing a warranty claims. Buffalo Corp will not be liable to warrant failures of warranted parts caused by the use of a non-exempted add-on or modified part.
- (11) The manufacturer issuing the warranty shall provide any documents that describe that manufacturer's warranty procedures or policies within five working days of request by the Air Resources Board.

#### EMISSION WARRANTY PARTS LIST

- (1) Fuel Metering System:
  - (a) Gasoline carburetor assembly and its internal components
  - (b) Carburetor gaskets
  - (c) Fuel line
  - (d) Clamps
  - (e) Fuel tank
  - (f) Fuel line fittings
  - (g) pressure regulator (if equipped)
  - (h) Mixer assembly and its internal components (if equipped)
- (2) Air induction system including:
  - (a) Intake pipe/manifold
  - (b) Air cleaner

- (3) Ignition system including: (a) Spark plug (b) Ignition coil
- (4) Catalytic muffler assembly including: (a) Muffler gasket (b) Exhaust manifold (c) Catalytic converter if available
- (5) Crankcase breather assembly including (a) Breather connection tube
- (6) Fuel tank evaporative emissions control system including:
  - (a) Purge valves (b) Carbon canister (c) canister Mounting Brackets (d) Fuel Cap (e) Fuel Tank
- (7) Miscellaneous items used in above systems including: (a) Switches (b) Hoses, belts connectors, and assemblies
- (8) Air injection system (a) Pulse valve

201901