





ASSEMBLY INSTRUCTIONS GABLE ARBOR



REVIEW ALL STEPS BEFORE STARTING ASSEMBLY

HARDWARE LIST **PRELIMINARIES**

		Quantity
A	 1 1/4" Screw	(28)
B	 2 1/2" Screw	(4)
C	Spacer block	
D	Anchor stake kit	

Selecting a Work Area
 Select an area close to where the arbor will be installed. The assembly area should be relatively flat and open, at least 9'x7'. A lawn, driveway or wide path will be satisfactory. It is a good idea to lay out the arbor box on your work surface to protect the arbor from nicks and scratches. Two people are handy for the assembly process. Always use caution when assembling or moving the arbor.

Optional Painting or Staining
 If you wish to stain or paint your arbor, we recommend applying to individual components before assembly to ensure fullest coverage. Use a high quality exterior stain or paint. Be careful not to cover up guide marks on arches.

PARTS LIST

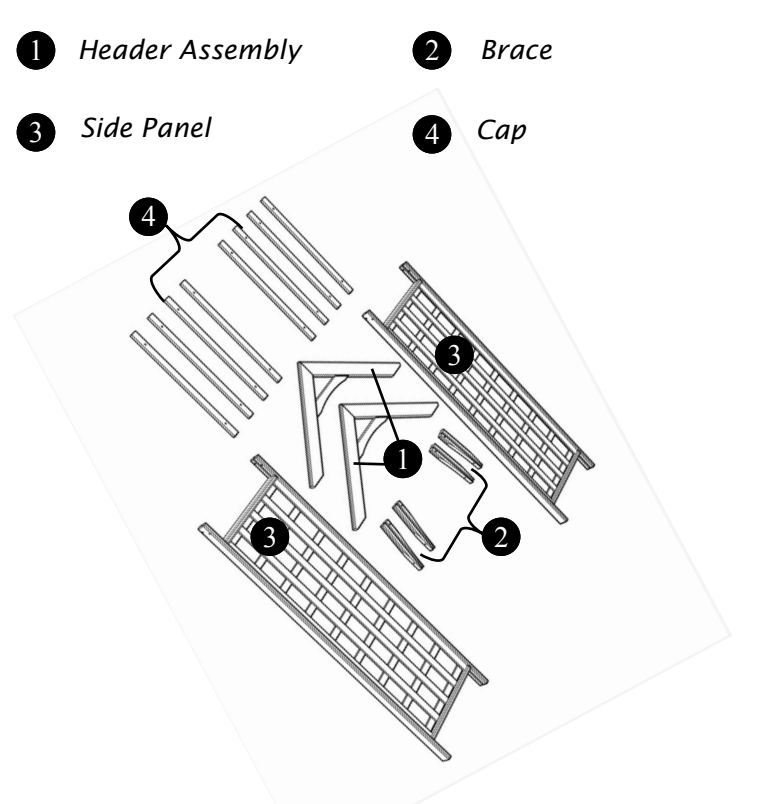

ASSEMBLED PRODUCT

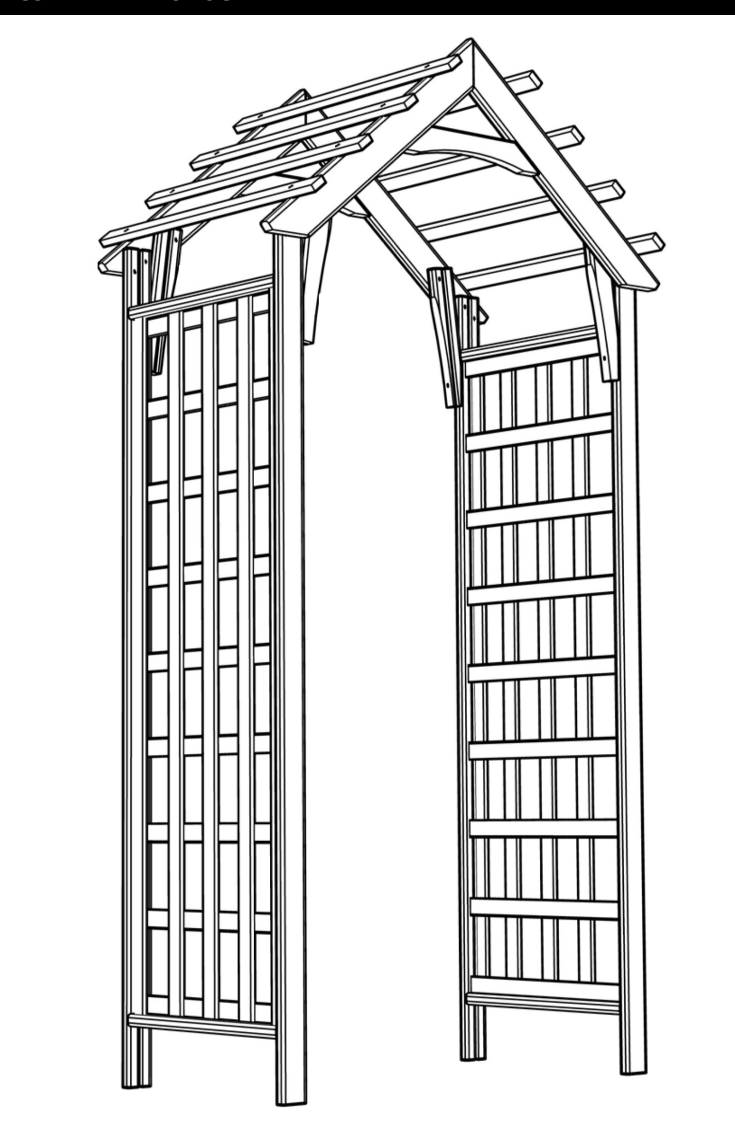

TOOLS REQUIRED

- Power screwdriver or drill
 - Tape measure
- Handy to have:
- Stool or short ladder
 - Bit holder may be needed if using a drill with a quick-change chuck

ASSEMBLY INSTRUCTIONS

GABLE ARBOR

STEP 1

Align bottom of each brace with pencil marks on side panel posts. Fasten in place as shown with a 2½" screw.

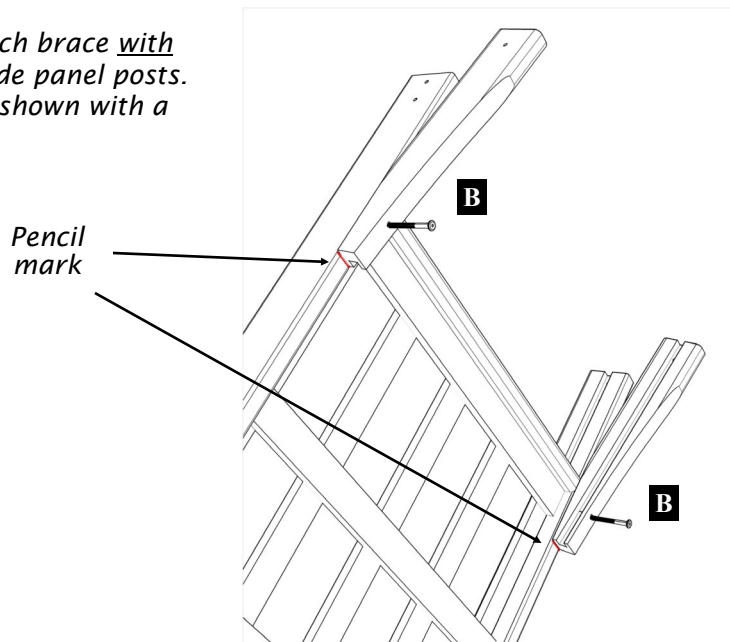

Repeat Step 1, attaching braces to the second side panel.

STEP 2

Align top of side panel post precisely with pencil mark on inside of header. Fasten post to header with a single 1¼" screw (second screw will be fastened later).

Fasten brace to header in the same fashion, using only a 1¼" single screw. Ensure post remains aligned with pencil mark.

IMPORTANT NOTE: Prior to repeating this step, as instructed below, measure the distance between the two side panels. The distance between the two panels at the top of the arbor must equal the distance between the two panels at the base of the arbor.

Repeat Step 2 with second side panel at other end of header.

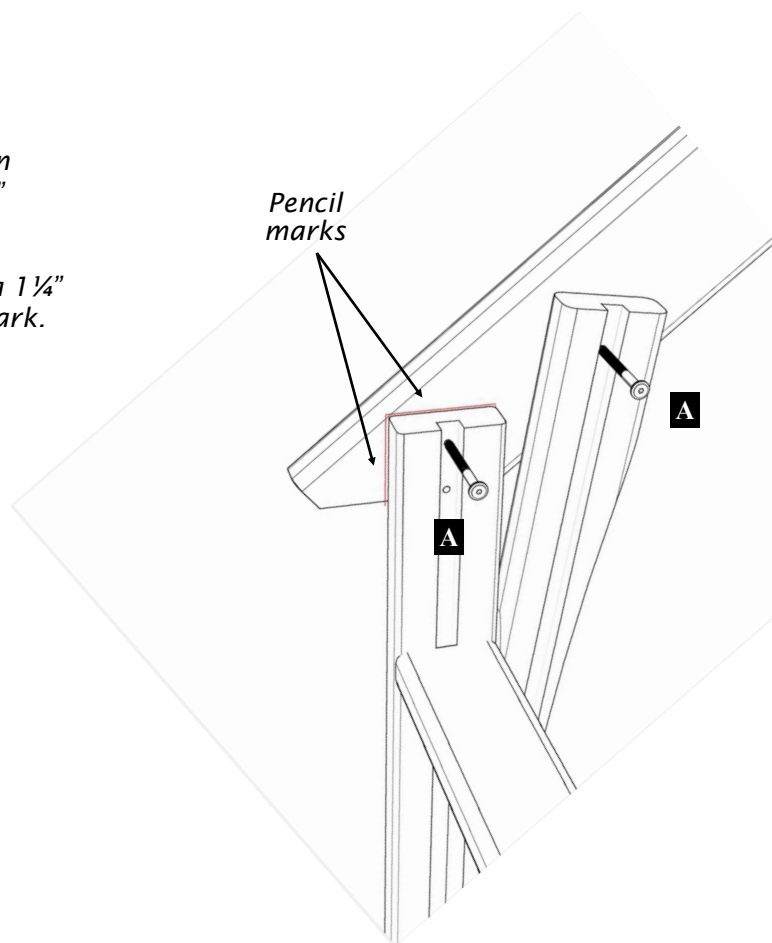

ASSEMBLY INSTRUCTIONS

GABLE ARBOR

STEP 3

- Repeat Step 2 to attach second header to the side panels.
- Carefully raise the arbor upright. Visually adjust the side panels as needed until arbor is plumb. Now drive the second screw on each post into the headers.

STEP 4

- Lay the arbor down, and elevate the arbor by placing wood blocks under the header. Using $1\frac{1}{4}$ " screws and the spacer block, align the caps and secure them to the headers by screwing through the pre-drilled holes
- Complete the assembly by attaching the remaining caps.

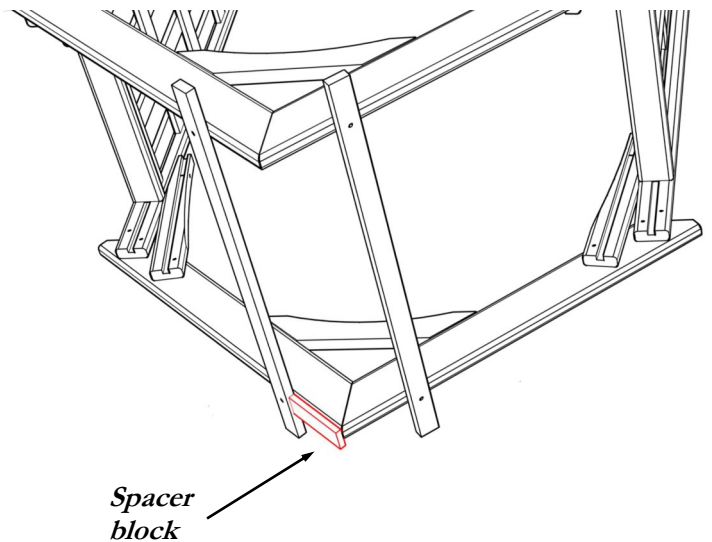

ASSEMBLY INSTRUCTIONS

GABLE ARBOR

OPTIONAL — ANCHORING THE ARBOR

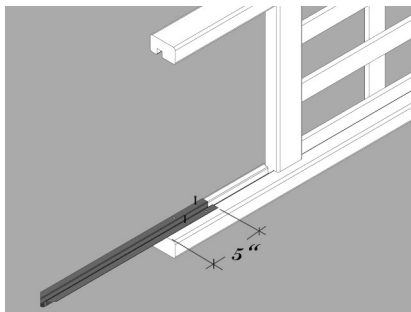

This arbor may be secured using a variety of techniques. These include attaching to an existing structure or anchoring with gravel or river rock instead of concrete. The instructions below represent secure mounting with concrete. Use caution when moving the arbor to its final placement. Two people are required to lift or move the arbor.

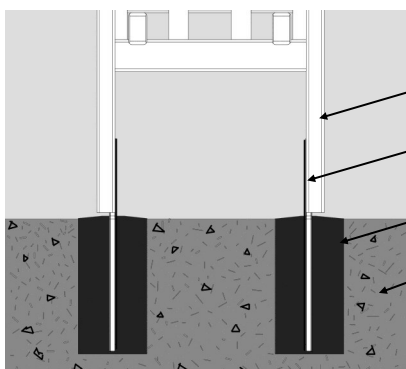

1. Attach all four anchors to the bottom of the arbor using the provided screws, two screws per anchor, staggering the screws.
2. Measure the distance in between all anchors and dig four 8" diameter holes to accommodate the anchors.
3. Carefully lift the arbor and position in place, avoid tilting the arbor on the anchors.
4. Plumb and level the arbor.
5. Mix concrete according to the manufacturer's instructions, fill each hole within 1/4" of the bottom of each post, posts should not be set in the concrete.

ENVIRONMENT

Congratulations, this garden structure is crafted from natural and chemical-free Western Cedar. Wood, as a building component, is recognized by the USDA¹ as yielding fewer greenhouse gases than other common materials. The use of wood provides substantial environmental benefits when compared to oil-based plastics. Using natural, untreated wood in your garden is not only the beautiful choice, but it reduces the exposure of plants, people and animals to potentially harmful chemicals.

You can trust the Arboria name for environmentally conscious, exceptional outdoor products.

¹USDA.com Release No. 0426.11

ABOUT YOUR PRODUCT

This garden structure is made from natural and untreated Western Cedar, a species that is known for its natural resistance to pests and decay. This product features furniture-style craftsmanship to ensure strength and durability over the years to come.

Like all wood products subjected to weather, small hairline cracks may develop. These should in no way impair the strength and usefulness of the furniture.

CARE AND MAINTENANCE

If left unstained, your garden structure will silver within a year or two of exposure to the elements. Silvering is a natural occurrence and is often considered a desirable look. The overall integrity of your garden structure is not compromised during this process. The inherent rot and pest resistance of the wood will provide a degree of protection and help your garden structure to endure over the years.

If you wish to further protect your structure from the long-term effects of aging or to stabilize the color/finish of your product, we recommend applying a quality water or oil-based finish. Best results can be achieved by using Penofin (www.penofin.com, 1.800.PENOFIN) as per manufacturer's instructions. If you desire to paint your product, we recommend a quality oil or acrylic primer coat prior to applying the final coat(s). Be sure to allow sufficient time for your product to dry.