



37.7cc Vibratory Screed Head Assembly

*Boards/Blades sold separately

Owner's Manual



TVSA-H & TVSA-T

Thank you for choosing The Tomahawk Power Screed TVSA-T and TVSA-H

For future reference, please complete the owner's record below:

Serial Number/Lot Date Code: _____

Purchase Date: _____

Save the receipt, warranty, and this manual.

This screed is designed for certain applications only. Tomahawk Equipment cannot be responsible for issues arising from modification or use of this product in an application for which it was not designed. We strongly recommend that this product not be modified and/or used for any application other than that for which it was designed.

For technical questions, please call [\(866\) 577-4476](tel:8665774476) .

Table of Contents

Intended Use	4
Technical Specifications	4
Important Safety Information	5
Specific Operation Warnings	8
Main Parts of the Screed	10
Assembly Instructions	11
Before Each Use	11
Operating Instructions	12
Starting the Engine	12
Operation	13
Stopping the Engine	13
After Each Use	13
Maintenance	14
Parts List	15
Troubleshooting	19
Replacement Parts	19
Limited Warranty	20

Intended Use

This screed uses vibration through a screed board to embed aggregate and reduce air voids in concrete making the slabs stronger. It can be used with a variety of board lengths including 6ft, 8ft, 10ft, 12ft, and 14ft on slab floors, roads, pavement or parking lots. Replacement boards and boards in other lengths are sold separately — see technical specifications page for part numbers.

Power Source. The screed is powered by a gasoline engine.

Supplies Required. Normal operation will require you to supply:

- Gasoline
- Engine oil
- Personal Protection Equipment

See “*Specifications*” section of this manual or the Engine Manual for more details.

Technical Specifications

Screed Head

	TVSA-H	TVSA-T
VIBRATIONS	7000vpm	5,500 vpm
Length	36”	64.1 in. (1,630mm)
Width	25”	24.8in. (630mm)
Height	40”	38.5 in. (980mm)
DRIVE SYSTEM	Flexible Shaft	Flexible Shaft
WEIGHT	42lbs (19kg)	48.5lb. (22kg)
Engine	Honda GX35 1.2kw	Tomahawk 37.7 cc
FUEL TANK Liter (gal)	.5 L	0.65 (172)
KW HP / RPM	1.6HP/ 7000RPM	1.6HP / 7,000RPM

Boards (sold separately)

Item #	49397	49398	49399	49400
Length	8 Ft (2438.4mm)	10 Ft (3048mm)	12 Ft (3657.6mm)	14 Ft (4267.2 mm)
Width	5.9 in (149mm)	←	←	←
Height	3.15 in (80mm)	←	←	←
Weight	13.7 lbs (6.2kg)	17.2 lbs (7.8kg)	20.5 lbs (9.3kg)	24 lbs (10.9kg)
Assembly type	Bolt & Nut	←	←	←

Material	Aluminum	←	←	←
-----------------	-----------------	---	---	---

Important Safety Information

⚠ WARNING

- The warnings, cautions, and instructions in this manual cannot cover all possible conditions or situations that could occur. Exercise common sense and caution when using this tool. Always be aware of the environment and ensure that the tool is used in a safe and responsible manner.
- DO NOT allow persons to assemble or operate this product until they have read this manual and have developed a thorough understanding of how the product works.
- Use the right tool for the job. DO NOT attempt to force small equipment to do the work of larger industrial equipment. There are certain applications for which this equipment was designed. It will do the job better and more safely at the capacity for which it was intended. DO NOT use this equipment for a purpose for which it was not intended.
- Industrial or commercial applications must follow OSHA requirements.

⚠ WARNING

- Some dust created by power sanding, sawing, grinding, drilling, and other construction activities contains chemicals known to the State of California to cause cancer, birth defects, or other reproductive harm. Some examples of these chemicals are:
 - lead from lead-based paints,
 - crystalline silica from bricks and cement and other masonry products, and
 - arsenic and chromium from chemically-treated lumber.

Your risk from these exposures varies, depending on how often you do this type of work. To reduce your exposure to these chemicals: work in a well-ventilated area, and work with approved safety equipment, such as dust masks that are specially designed to filter out microscopic particles.
- Handling the power cord on corded products may expose you to lead, a chemical known to the State of California to cause cancer and birth defects or other reproductive harm. Wash hands after handling.

⚠ WARNING

WORK AREA SAFETY

- Inspect the work area before each use. Keep the work area clean, dry, free of clutter, and well lit. Cluttered, wet, or dark work areas can result in injury.
- Do not use the Screed where there is a risk of causing a fire or an explosion; e.g., in the presence of flammable liquids, gases, or dust.
- Do not allow the tool to come into contact with an electrical source. The tool is not insulated and contact will cause electrical shock.
- Keep children and bystanders away from the work area while operating the Screed. Do not allow children to handle the Screed.

- Be aware of all power lines, electrical circuits, water pipes, and other mechanical hazards in your work area. Some of these hazards may be hidden from your view and may cause personal injury and/or property damage if contacted.

⚠ WARNING

PERSONAL SAFETY

- Stay alert, watch what you are doing, and use common sense when operating the Screed. Do not use the Screed while you are tired or under the influence of drugs, alcohol, or medication.
 - Dress properly. Do not wear loose clothing, dangling objects, or jewelry. Keep your hair, clothing and gloves away from moving parts. Loose clothes, jewelry, or long hair can be caught in moving parts.
 - Use ANSI Z87.1-approved safety goggles or safety glasses with side shields, or when needed, a face shield. Use a dust mask in dusty work conditions. Also use non-skid safety shoes, hardhat, gloves, dust collection systems, and hearing protection when appropriate. This applies to all persons in the work area.
 - Do not overreach. Keep proper footing and balance at all times.
 - Remove adjusting keys or wrenches before starting the Screed. A wrench or key that is left attached to a rotating part of the Screed may cause personal injury.
 - No smoking, matches, or open flames around machine. Fuel is flammable.
 - Do not touch hot surfaces.
 - Engine exhaust contains carbon monoxide. This is a poison you cannot see or smell. NEVER use
-

⚠ CAUTION

SCREED USE AND CARE

- Do not force the Screed to perform an operation other than its intended use. Screeds do a better and safer job when used in the manner for which they are designed. Plan your work, and use the correct Screed for the job.
- Check for damaged parts before each use. Carefully check that the Screed will operate properly and perform its intended function. Replace damaged or worn parts immediately. Never operate the Screed with a damaged part.
- Store the Screed when it is not in use. Store it in a dry, secure place out of the reach of children. Inspect the Screed for good working condition prior to storage and before re-use.
- Use only accessories that are recommended by the manufacturer for use with the Screed. Accessories that may be suitable for one Screed may create a risk of injury when used with another Screed.
- Keep guards in place and in working order.
- Keep the Screed board clean.
- Do not leave the Screed running unattended.
- Shut off the fuel valve when the engine is not in use.
- Only use the recommended fuel to avoid damaging the equipment.
- Oil does not come with the machine. Add oil to engine before the first use.
- Check oil levels before operating the machine.
- DO NOT refuel the engine while it is still hot. Fuel is flammable.
- DO NOT service engine while it is still hot.

Specific Operation Warnings

⚠ WARNING

To avoid fatal accident

- Stop the engine before refueling and be careful not to spill fuel during the refueling. Spilled fuel may ignite causing a fire.
- Do not refuel the engine near flammable objects to avoid fire.
- Do not run the engine in enclosed areas to prevent carbon monoxide poisoning.

To protect the operator

- When fatigue from operation, the operator must stop the machine and take break.
- Hearing protection is required as this machine creates a noise emission while 1 m (3 feet) away from the equipment.

To avoid injury or damage

- The plate compactors are only operated by authorized persons who:
 - are at least 18 years of age.
 - are physically and mentally able to operate the screed.
 - are properly trained in the operation and the maintenance of the screed by the owner or its authorized representative.
 - are assessed to be able to carry out their duties reliably.
- People who are drinking alcohol beverages and/or taking drugs are not allowed to operate the plate compactor.
- People are not allowed to enter into the danger zone of the screed.
- The operator has to monitor the danger zone all the time. It is not allowed to operate if there is a person in the danger zone.
- The operator has to give warning signs in case of an emergency situation.
- The screed can only be operated when the adequate stability is granted.
- The operator has to control the running speed of the screed all the time during its operation so that the screed can be stopped at any time.
- The operator must turn off the screed completely as described in this manual before leaving the operating position. Also, the screed must be secured against unauthorized use.
- The engine has to be turned off and secured against re-starting by pulling out the sparking plug socket during the maintenance and servicing.
- The operator has to control the screed as regards functions and obvious defects before use.
- Discovered defects must be reported to supervising personnel and to the operator. Do not leave the defects which may cause serious injury of the operator.
- Do not operate the screed when a defect endangers the safety of the operator until the defect is rectified.
- The screed has to be checked by an expert in regular bases (at least once a year). And it must be checked by an expert before the initial use and after the essential modification.
- During the operation, the operator has to monitor other objects within a radius of 20m in case of lighting.
- The screed generates mechanical heat so do not touch the body of engine, muffler or other parts during the operation, which may cause heat burn. Please wait until it cools down to touch.

- The operator must be fully equipped with safety equipment including a crash helmet, safety gloves, safety shoes, safety glasses and mask before operating the screed.
- Do not transport the screed with fuel in its fuel tank by the motor vehicle.
- Do not lift the screed by a person when putting on and off from vehicle. Always use a proper lifting crane to move. Lifting by person may cause personal injury due to its heavy weight.
- Make sure to securely fasten the screed for transportation. Improper fastening as holding the handle of the screed during the transportation may cause an injury.

Note: Refer to the instruction manual of the engine if there is a problem or a question about it before or during its operation.

Main Parts of the Screed

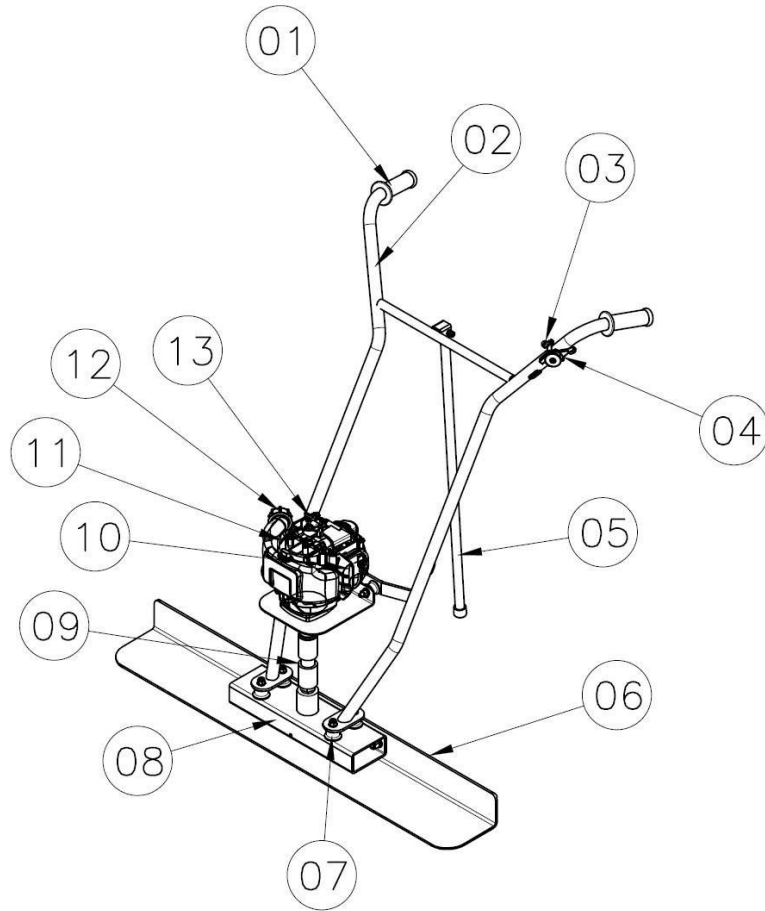

01	Handle Rubber
02	Handle
03	Engine Stop Switch
04	Engine Throttle Lever
05	Stand Pipe
06	Board
07	Isolate Rubber
08	Vibratory Housing
09	Flexible Hose
10	Engine Muffler
11	Priming Bulb
12	Engine Fuel Cap
13	Engine Recoil Starter

Assembly Instructions

1. Put a desired length screed board on solid ground.
2. Locate the screed head in the middle of screed board by the holes in the rear flange of the board.
3. Attach the screed to the rear flange of the screed board with bolts and nuts (see the Screed Board section of the parts list). Tighten the bolts and nuts with 87.3 lbf-ft (1200 kgf-cm) of torque.
4. For the TVSA-H model with a Honda Engine. Attach desired screed board with 4 bolts to assembly. Next adjust handles to desired position with Allen wrench. Last, tighten accelerator to handle position.

Before Each Use

Preparation for operation

- 1) Check all bolts, nuts and belts and tighten any that are loose.
- 2) Get the desired length of screed board.

Recommended Fuel

- 1) The screed engine requires regular unleaded gasoline. Use only fresh, clean fuel. Fuel containing water or dirt will damage the fuel system. Consult engine owner's manual for complete fuel specifications.

Before starting Engine

- 1) Read and understand the safety and operating instructions manual for the engine.
- 2) Check :
 - Oil level in engine.
 - Fuel level.
 - Condition of air cleaner.
 - Tightness of external fasteners.
 - Condition of fuel lines.
 - Wear of spark plug

Operating Instructions

⚠ WARNING

Read and understand both the screed user's manual (this manual) and the engine manual before starting or operating the screed to avoid incorrect operation that may result in damage or injury.

Starting the Engine

1. Perform all the Before Each Use steps.
2. To start a cold engine, move the choke lever to the CLOSED position.
If restarting a warm engine leave the choke lever in the OPEN position.

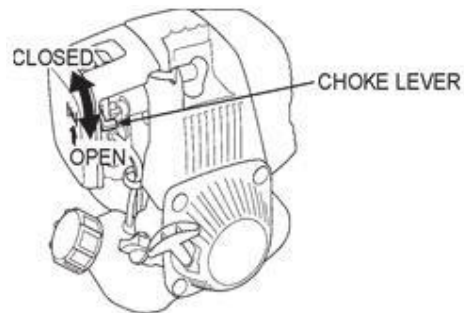

3. Press the priming bulb repeatedly until fuel can be seen inside the clear plastic bulb.

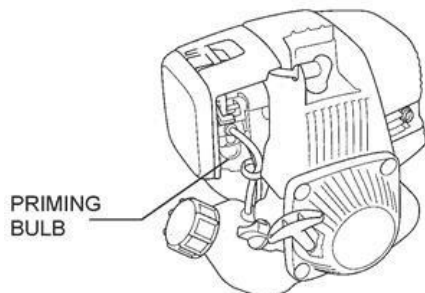

4. Move the throttle lever slightly in the direction of the arrow.
5. Pull the starter rope (Figure 03) lightly until you feel resistance, then pull briskly in the direction of the arrow. Return the starter rope gently.

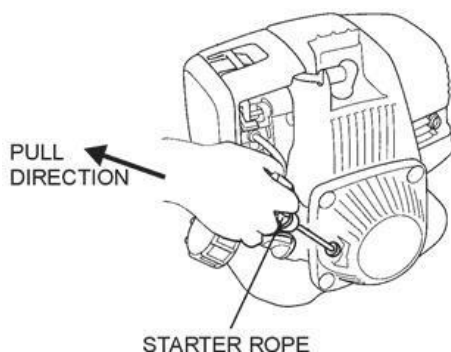

6. Once the engine has started, open the choke and allow engine to idle for 3 to 5 minutes to warm-up.

Operation

⚠ WARNING

Read and understand both the engine and compactor user's manuals before starting or operating the compactor to avoid incorrect operation that may result in damage or injury.

Note: Whenever high speed operation is NOT required, slow the engine by moving the throttle lever to a low position to save fuel and extend the life of the equipment.

1. Once the engine has started and warmed up, open the throttle fully in the direction of the arrow to operate the screed.
2. Slowly move the screed backwards watching for smooth concrete in front of the screed.

Stopping the Engine

⚠ CAUTION

In an emergency situation, turn off the engine switch immediately. In normal conditions, do not stop the engine when the screed is at high speed or the engine temperature will rise suddenly, possibly causing engine parts to jam or the oil to deteriorate.

Note: To stop the engine in an emergency, simply press the Emergency Stop Switch on the handle.

To stop the engine normally:

1. Reduce the engine speed by moving throttle completely in the opposite direction of the arrow and let the engine idle for 2 - 3 minutes before turning it off.
2. Press the emergency stop switch on the handle.

Please see the instruction manual of engine for further detailed information.

After Each Use

Cleanup

Clean the screed and screed board. Clean the screed and screed board with water to remove all concrete but take care that the engine does not get wet. The screed board can be thinly coated with diesel fuel to help prevent rust and more easily remove concrete.

Clean the engine cylinder cooling fins. A broom or old brush are good tools to remove concrete before it becomes solid.

Refer to the engine manual for more information about the engine.

Storage

In case of storing the screed and board for a long period of time (for more than 30 days):

- 1) Clean the screed as described above.
- 2) Remove the board from the screed as described in this manual.
- 3) Drain the fuel tank and run the engine briefly until the fuel in the fuel in the carburetor is completely consumed
- 4) Change the engine oil and follow procedures described in engine manual for engine storage.
- 5) Clean or replace the engine air filter.
- 6) Store the Screed and board separately in a clean, dry area.
- 7) Cover the screed and board completely with dry cloth.

Maintenance

⚠ WARNING

Check that the compactor engine is turned off and cooled before attempting any maintenance, cleaning, or inspection. Performing maintenance on an operating compactor can cause injury.

Maintain the Screed by adopting a program of conscientious repair and maintenance in accordance with the following recommended procedures: Also refer to the engine manufacturer's instruction manual for additional information about engine maintenance. The following chart is based on a normal operation schedule.

Maintenance Interval	Maintenance Point
Daily before operating	Check the fuel level. Check the engine oil level. Inspect the fuel lines. Inspect the air filter and replace it if needed. Check and tighten the external hardware.
After the first 20 operating hours or 3 months	Change the engine oil.
After the first 50 operating hours or every 6 months	Clean the air cleaner element. Change the engine oil. Check and clean the spark plug.
After the first 100 operating hours or every year	Clean the fuel strainer.
After the first 200 operating hours or every 2 years	Check and adjust the valve clearance. Clean the cylinder head. Replace the spark plug.

Screed Assembly TVSA-H



Line up blade with assembly.



Attach washers, locking screws, and bolts.



Repeat Step 2 for the second hole.



Connect accelerator cable to engine.



Locate accelerator screw found on HONDA engine and place cable through the gap.



Tighten and make sure that when you pull accelerator handle, the cable engages engine.

Screed Assembly TVSA-T

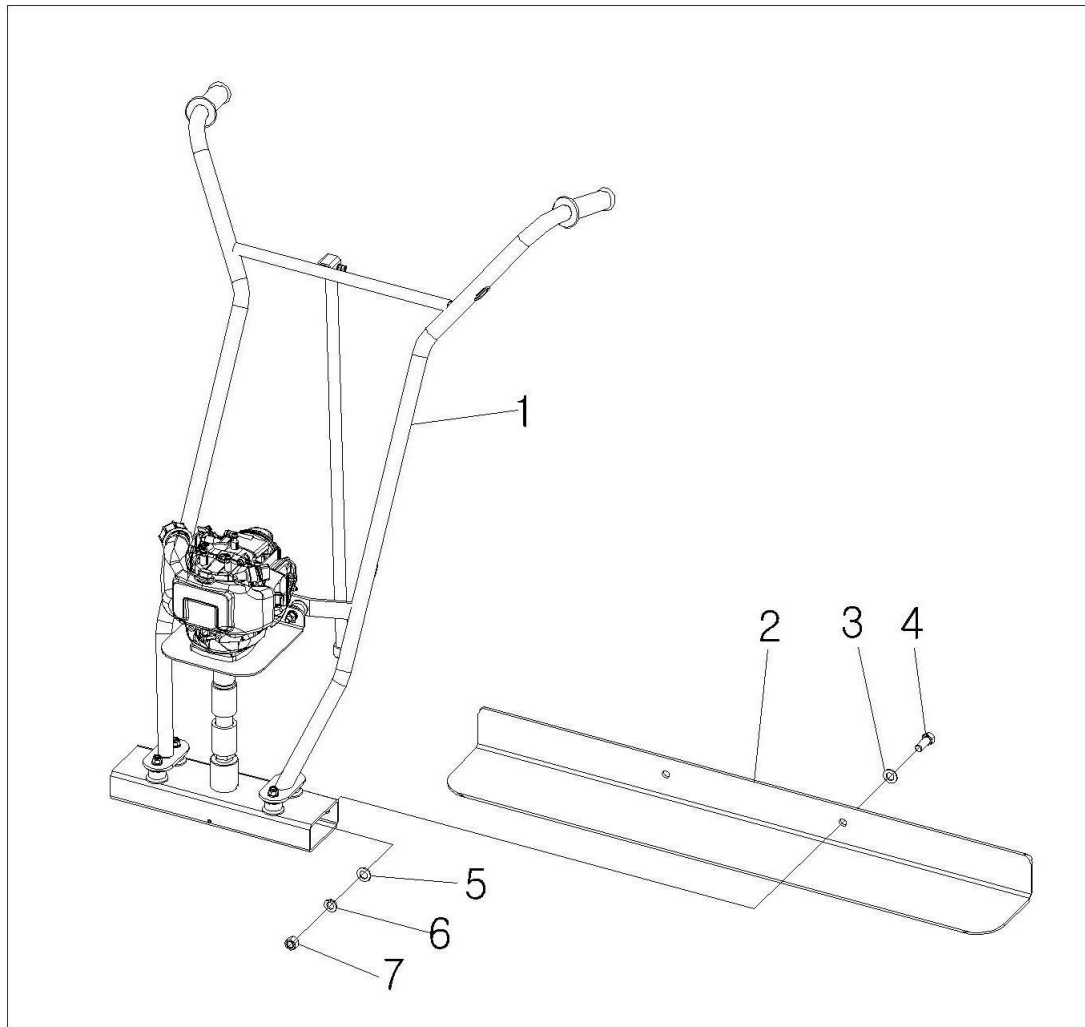

No.	Descriptions	Qty	Size or Dimension
1	Vibrator Screed	1	
2	Screed Board 8 Feet	1	8ft
	Screed Board 10 Feet	1	10ft
	Screed Board 12 Feet	1	12ft
	Screed Board 14 Feet	1	14ft
3	Plain Washer	2	M12
4	Bolt	2	M12x30
5	Plain Washer	2	M12
6	Spring Washer	2	M12
7	Cap Nut	2	M12

Explosion Diagram TVSA-T

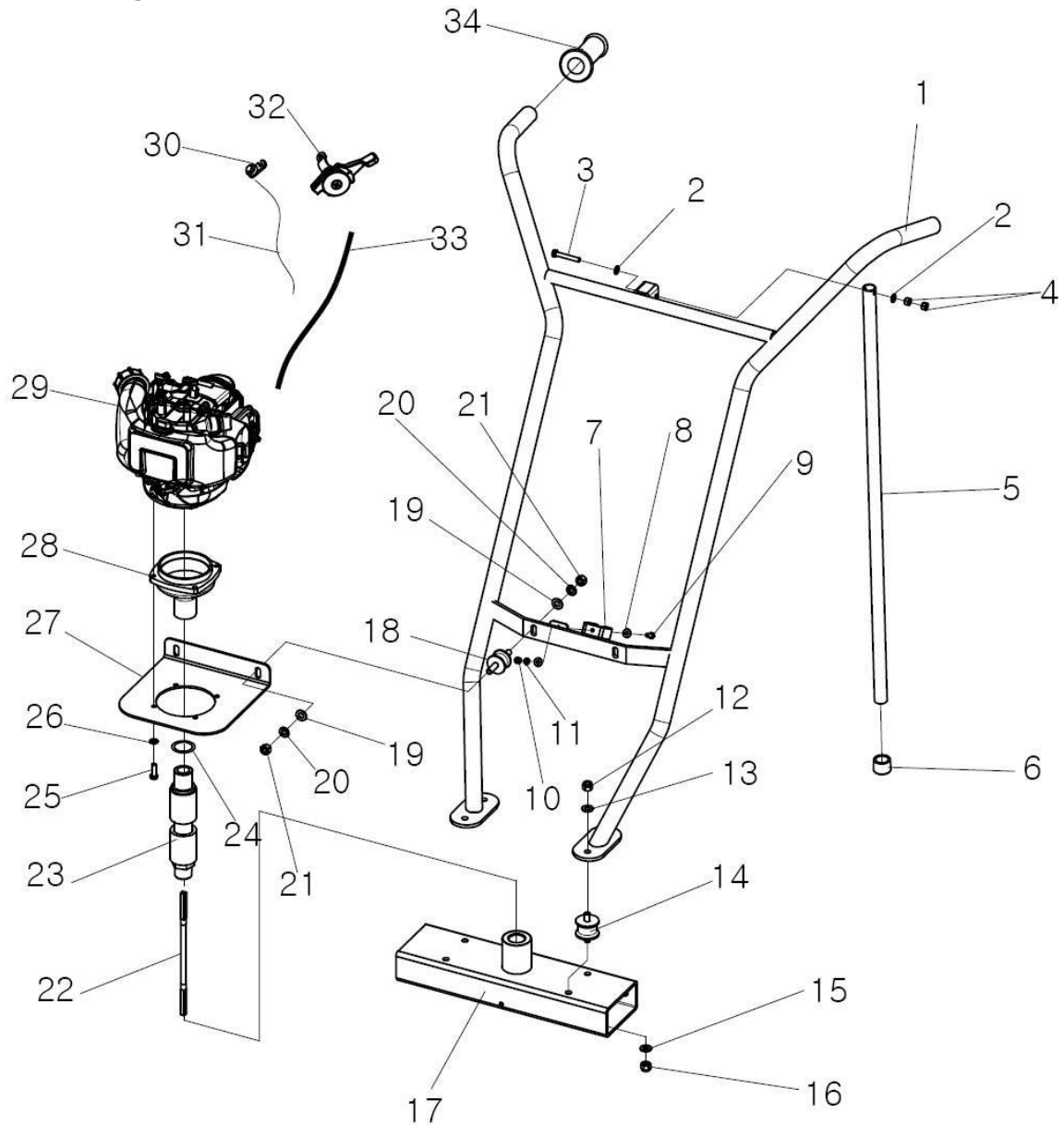

No.	Descriptions	Qty	Size or Dimension
1	Handle Welding Assembly	1	
2	Plain Washer	2	
3	Bolt	1	M6*40L
4	Nut	2	M6
5	Handle Support Pipe	1	
6	Handle Support Pipe Rubber	1	
7	Clip	1	

No.	Descriptions	Qty	Size or Dimension
8	Plain Washer	2	M5
9	Bolt	1	M5x15
10	Nut	1	M5
11	Spring Washer	1	M5
12	Cap Nut	4	M8
13	Plain Washer	4	M8
14	Handle Support Rubber	4	
15	Plain Washer	4	M8
16	Cap Nut	4	M8
17	Vibratory Housing Assembly	1	
18	Handle Support Rubber	2	
19	Plain Washer	4	M8
20	Spring Washer	4	M8
21	Nut	4	M8
22	Wire	1	
23	Hose Assembly	1	
24	O-Ring	1	P20
25	Bolt	4	M6x20L
26	Spring Washer	4	M6
27	Engine Plate	1	
28	Clutch Housing Assembly	1	
29	Engine	1	Tomahawk 37.7cc
30	Engine Stop Switch	1	
31	Engine Electric Stop Wire	1	
32	Throttle Lever Lever	1	
33	Throttle Lever W/ Cable	1	
34	Handle Rubber	2	

Explosion Diagram TVSA-H

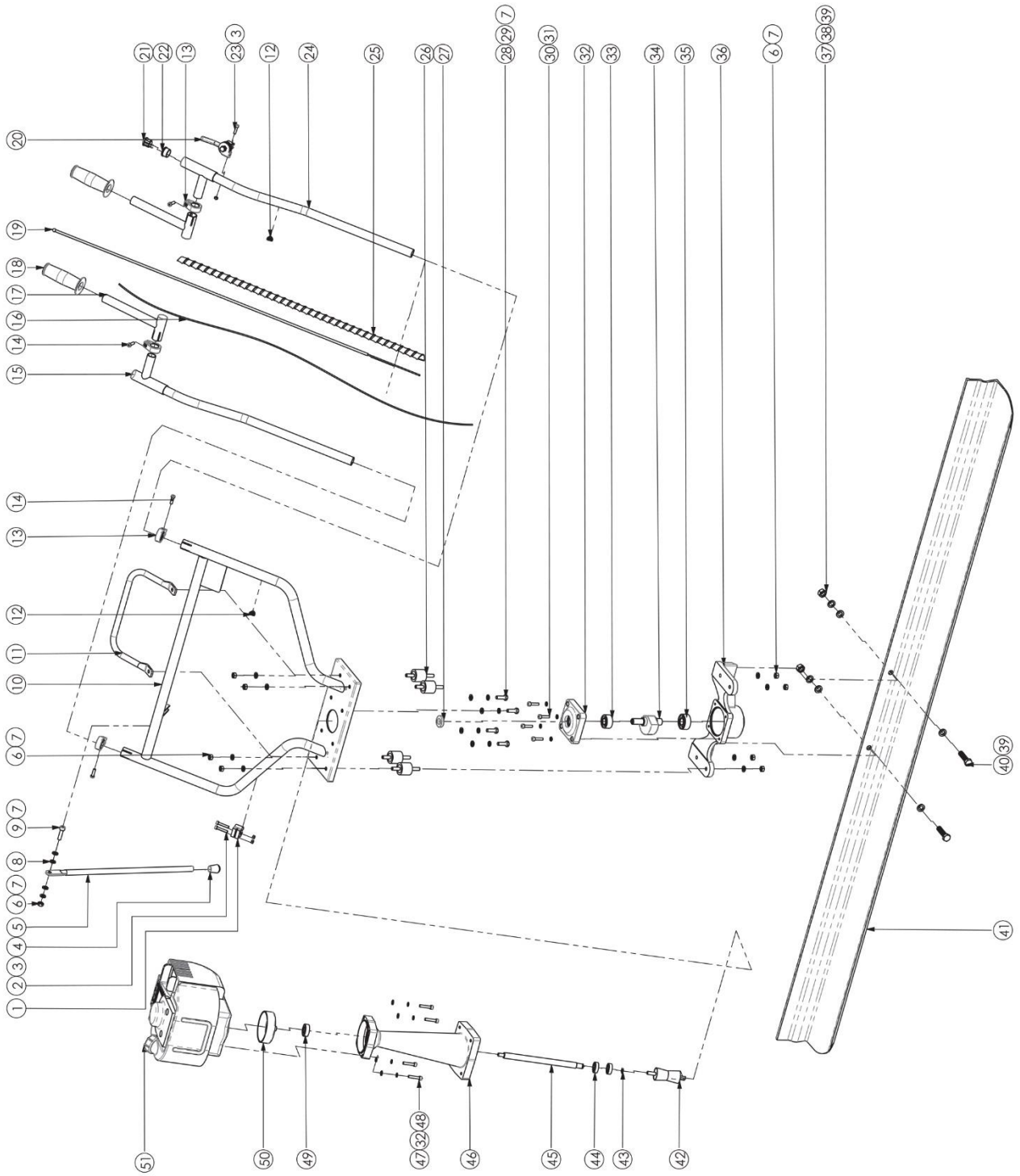

S/NO	DESCRIPTION	QTY
1	STAND HOLDER	1
2	BOLT M5X30	2
3	LOCK NUT M5	3
4	STAND RUBBER	1
5	STAND	1
6	LOCK NUT M8	9
7	WASHER M8	14
8	PACKING	2
9	BOLT M8X25	2
10	HANDLE LONG	1
11	ENGINE FRAME	1
12	TIE RAP	2
13	HANDLE CLIP	4
14	BOLT M6X20	4
15	HANDLE GRIP (RIGHT)	1
16	SWITCH CABLE	1
17	HANDLE SLIP	2
18	GRIP	2
19	THROTTLE CABLE	1
20	THROTTLE LEVER ASSY	1
21	SWITCH	1
22	SWITCH BRACKET	1
23	BOLT M5X20	1
24	HANDLE GRIP (LEFT)	1
25	THROTTLE CABLE GUIDE PIPE	1
26	VIBRO MOUNT	4
27	OIL SEAL 15X30X7	1
28	BOLT M8X30	4
29	SPRING WASHER M8	4
30	SOCKET HEAD BOLT M6X25	4
31	SPRING WASHER M6	8
32	VIBRATION COVER	1
33	BEARING 5202 2RS	1
34	COUNTER WEIGHT	1
35	BEARING 6203 2RS	1
36	HOUSING WEIGHT	1
37	LOCK NUT M12	2
38	SPRING WASHER M12	2
39	WASHER M12	4
40	SOCKET HEAD BOLT M12X45	2
41	ULTRA FLAT PLATE	1
42	DRIVE AXLE	1
43	CLIP Φ 12	1
44	BEARING 6001ZZ	2
45	DRIVE SHAFT	1
46	HOUSING SHAFT	1
47	SOCKET HEAD BOLT M6X35	4
48	WASHER M6	4
49	BEARING 6201ZZ	1
50	CLUTCH DRUM	1
51	ENGINE	1

Troubleshooting

Please check the list below before addressing the problems to servicing personnel including local dealer. And if the problem continues after the troubleshooting as described below, call your local dealer for future assistance.

Failure	Possible Cause	Remedial Measure
Vibrates insufficient and as a result the concrete floor can't be leveled and smoothed in the proper way.	The centrifugal force is too low.	Increase engine speed.
	There are excessive amounts of concrete along the leading edge of the board.	Remove the excessive concrete from the board.
	The chosen width of the board is too large	Work with a smaller board.
Concrete looks "WAVY" as the screed board passes over it	Operator moving too slowly	Walk backwards at a faster pace.
	Too much vibration for the type of concrete	Reduce engine speed and walk backwards at a faster pace.
Leaving HIGH or LOW spots during wet screeding.	Concrete too high or low on one side?	Have workers shape the concrete close as possible to grade. Maintain about 1 inch of concrete across the front of the board at all times.
Board digs into wet concrete.	Is board positioned correctly?	Each end of the board must ride on the same surface. Either each end of the board rides on forms or concrete (wet screed) not both.

Replacement Parts

- For replacement parts and technical questions, please call Customer Service at [\(866\) 577-4476](tel:8665774476).
- Not all product components are available for replacement. The illustrations provided are a convenient reference to the location and position of parts in the assembly sequence.
- When ordering parts, the following will be required: model number, serial number/lot date code, and description.
- The distributor reserves the rights to make design changes and/or improvements to product lines and manuals without notice.

Limited Warranty

Tomahawk Power LLC. ("We" or "Us") warrants to the original purchaser only ("You" or "Your") that the Tomahawk product purchased will be free from material defects in both materials and workmanship, normal wear and tear excepted, for a period of **1 year** from date of. The foregoing warranty is valid only if the installation and use of the product is strictly in accordance with product instructions. There are no other warranties, express or implied, including the warranty of merchantability or fitness for a particular purpose. If the product does not comply with this limited warranty, Your sole and exclusive remedy is that We will, at our sole option and within a commercially reasonable time, either replace the product or product component without charge to You or refund the purchase price (less shipping). This limited warranty is not transferable.

Limitations on the Warranty

This limited warranty does not cover: (a) normal wear and tear; (b) damage through abuse, neglect, misuse, or as a result of any accident or in any other manner; (c) damage from misapplication, over-loading, or improper installation; (d) improper maintenance and repair; and (e) product alteration in any manner by anyone other than Us, with the sole exception of alterations made pursuant to product instructions and in a workmanlike manner.

Obligations of Purchaser

You must retain Your product purchase receipt to verify date of purchase and that You are the original purchaser. To make a warranty claim, contact Us at [\(866\) 577-4476](tel:8665774476), identify the product by make and model number, and follow the claim instructions that will be provided. The product and the purchase receipt must be provided to Us in order to process Your warranty claim. Any returned product that is replaced or refunded by Us becomes our property. You will be responsible for return shipping costs or costs related to Your return visit to a retail store.

Remedy Limits

Product replacement or a refund of the purchase price is Your sole remedy under this limited warranty or any other warranty related to the product. We shall not be liable for: service or labor charges or damage to Your property incurred in removing or replacing the product; any damages, including, without limitation, damages to tangible personal property or personal injury, related to Your improper use, installation, or maintenance of the product or product component; or any indirect, incidental or consequential damages of any kind for any reason.

Assumption of Risk

You acknowledge and agree that any use of the product for any purpose other than the specified use(s) stated in the product instructions is at Your own risk.

Governing Law

This limited warranty gives You specific legal rights, and You also may have other rights which vary from state to state. Some states do not allow limitations or exclusions on implied warranties or incidental or consequential damages, so the above limitations may not apply to You. This limited warranty is governed by the laws of the State of California, without regard to rules pertaining to conflicts of law. The state courts located in San Diego County, California shall have exclusive jurisdiction for any disputes relating to this warranty.



Distributed by
Tomahawk Power LLC
[\(866\) 577-4476](tel:8665774476)