

6779-4322 Closet Rod Closet System ©2012 Whitmor, Inc.

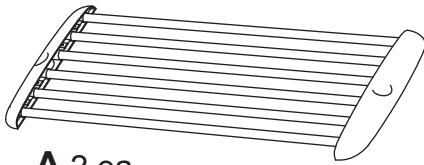

A 2 ea
Shelf assembly



E 3 ea
Foot



F 4 ea
Shelf locking collar

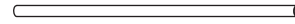

I 1 ea
Hanging rod

Assembly Time:
Less than 45 minutes.

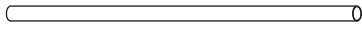

B 3 ea
Bottom vertical pole

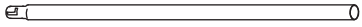

C 3 ea
Middle vertical pole



D 3 ea
Top vertical pole with claw



G 3 ea
Vertical pole lock assembly
(These two parts are pre-assembled)



H 2 ea
Hanging rod lock assembly
(These two parts are pre-assembled)

This product's intended use is for hanging garments and storage.

Tools Needed: No tools required.

STEP 1. Start by sliding shelf locking collar (F), then shelf assembly (A) onto bottom two bottom vertical poles (B). Repeat for second shelf assembly. Insert two feet (E) into bottom of bottom vertical poles (B).

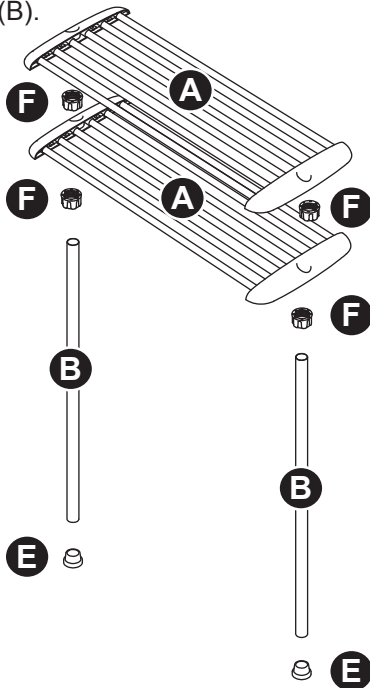

STEP 2. Loosen two hanging rod lock assemblies (H) and slide onto one side of assembled shelf section from step 1. Slide the other (H) onto remaining bottom vertical pole (B). Insert each end of hanging rod (I) into (H) on both and tighten. Insert and lock all three middle vertical poles (C) by sliding into (B) and locking. Hanging rod can now be repositioned higher onto vertical pole (C) if desired. Insert remaining foot (E) onto bottom of (B).

Part	Reference
A	F7495
B	F7496
C	F7497
D	F7498
E	F7499
F	F7500
G	F7501
H	F7502
I	F7503

MADE IN CHINA



8680 Swinnea Road • Suite 103 • Southaven, MS • 38671

NEED HELP? For help with assembly, or if you are missing a part, please call Whitmor's Customer Service Department, 1-888-944-8667 between 8 a.m. and 4:30 p.m. (Central Standard Time) Monday through Friday. Or email: customer_service@whitmor.com. Visit us online at www.whitmor.com

STEP 3. Place three vertical pole lock assemblies (G) onto top of middle vertical poles (C). Insert top vertical poles with claw (D) and tighten (G).

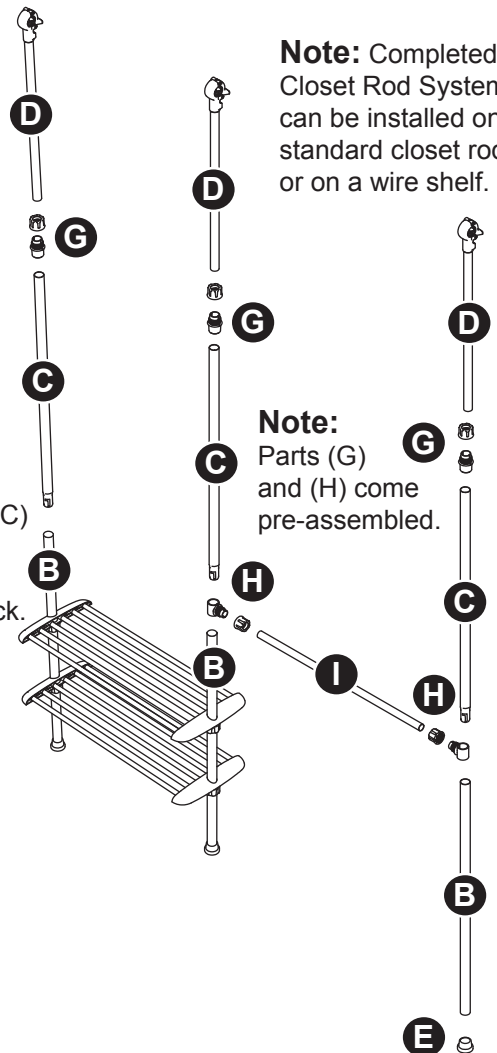

Note: Completed Closet Rod System can be installed on a standard closet rod, or on a wire shelf.

Note: Parts (G) and (H) come pre-assembled.

Note: Poles (B&C) slide into groove and twist to lock.