



Zest Model CVZ135

DC22V 2200 mAh output
Lithium Ion battery



Care and Use Instructions

Ewbank LLC,
8261 Highway 73, Suite F, Stanley, NC 28164, USA
Tel: 855-439-2265
Email: enquiries@ewbankus.com

www.ewbankus.com

DO NOT VACUUM LIQUIDS WITH THIS PRODUCT



Thank you for buying your Ewbank Zest®, we hope you enjoy using it. Please read these instructions carefully before using your Zest® cordless vacuum and retain these instructions for future reference.

Pack Contents:

- 1) Handheld unit
- 2) Upright body/handle assembly
- 3) Motorized floor brush
- 4) Charging stand
- 5) Charging cable (requires assembly)
- 6) Tool adaptor for use with 7, 8 & 9
- 7) Extension tubes (x 2)
- 8) Round upholstery brush
- 9) Crevice tool with brush
- 10) Cleaning brush and cutter
- 11) Air fresheners (x 2)
- 12) Locking screw

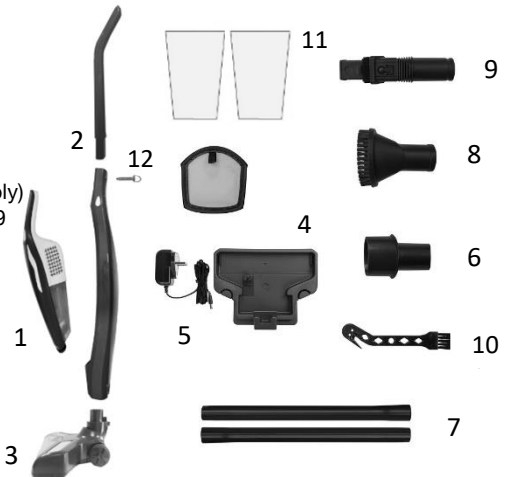

Fig.1

Read the instruction manual before using the Ewbank Zest and make sure that:

- Pack contents are correct.
- The power cord on the charging base is in perfect condition.
- All packaging materials are removed from the product.

Safety Instructions – CAUTION



DO NOT:

- Modify the product in any way – this is dangerous and will void the warranty.
- Handle the product with wet hands.

WARNING!

1. Follow the assembly process in this manual. The manual will give the important instructions about the assembly and safety.
2. After unpacking, make sure that the product is intact with no visible signs of damage caused by transport, should you have any doubts, do not use the product and call our Quality department. All packing materials (plastic wrapping, cardboard box, etc.) are potentially dangerous and must be kept out of children's reach.
3. This product is only designed for domestic applications, any other usage is unsuitable and will not be covered by warranty.
4. Before charging the product for the first time, check that the rating plate specifications on the adaptor correspond to your electrical power supply.
5. The product must only be used with the charging adaptor supplied with the product or a replacement purchased from Ewbank or one of our distributors.
6. Never use the charging station with multiple plug or extended power cord. The charging plug needs to fit directly into the socket.
7. Don't plug the equipment into other devices such as timer, remote controlled device or similar equipment.
8. Please do not leave the product when it is powered on.
9. After charging has finished, and you are removing from the wall socket, pull out by the plug of adaptor only, do not pull by the power cord or charging station.
10. Before cleaning and maintaining the product, please remove the power cord from the outlet and switch off the machine.
11. If the product stops working or there is an abnormal sound, please switch the power off and contact our Service Department.
12. Never try to replace the power cord. If the cord or plug is damaged or needs to be replaced then please contact our Service Department.
13. NEVER pick up flammable or combustible liquids such as gasoline, other volatile substances or burning embers.
14. NEVER use in the presence of explosive liquids, vapors or explosive dust such as coal or grain.
15. This product can only be used by children aged from 14 years and above. Persons with reduced physical, sensory or mental capabilities or lack of experience and knowledge must have been given supervision or instruction concerning use of the product in a safe way and understand the hazards involved. Children must not play with the product.
16. Never use on a wet floor, do not allow to get wet in the rain. Otherwise the motor will be at high risk of being burnt out.
17. The product should be kept far away from heat sources (such as central heating radiators, ovens, etc.) to avoid damage to the product.
18. Before using the product, please remove any large or sharp matter on the floor to avoid damaging the plastic parts, filter and motor.
19. When using the product, pay close attention to preventing any materials to block up the air inlet (including the tubes), otherwise damage may be caused to the motor and the body of

the product. If the collected matter forms a blockage, stop the product immediately by switching the unit off. Use the cleaning brush with cutter to clean the blockage.

20. When the roller brush is running, take care to avoid touching it with hands, feet or allowing your hair to get trapped.
21. If the roller brush is not running due to being blocked, the motor safety switch will engage in order to prevent motor damage. At the same time, the motor will stop running and you must wait 8-10 seconds, then the motor will start to run again.
22. In order to protect the battery, the unit cannot be switched on while it is being charged, the unit will not operate.
23. If you are replacing the batteries, the old batteries must be correctly recycled.
24. Please use the product according to these instructions and use only Ewbank accessories.
25. The battery is Lithium-Ion, rechargeable. Each of the 6 cells is 3.7V these are packaged into a single unit. The maximum power capacity is 2200mAh.
26. For initial charging, insert the power cord into the wall socket and the other end insert into the main body or the charging station, the indicator light will flicker until the battery is full, then indicator light will switch off. It should take 8 hours for this process on the first charge.

The battery should be fully charged before first use.

Fig.2



Charging your Zest

1. Fix the handle to the main body by using the locking “screw” to secure the handle in place.
2. Attach the motorized floor brush onto the base of the main unit/body. Ensure the locking clip at the back of the unit is secure and the electrical connection between the product and the brush is made.
3. Insert the plug of the charger into the electrical outlet and the other end into the charging point (located on the bottom side of the charging base). For your safety the charging voltage must be as described in the instruction manual.
4. Place the Zest on the charger base, the handheld unit must be fitted into the upright unit/body for charging to take place.
5. When the product is being charged, the neon light on the handheld vacuum cleaner flashes continuously. When the indicator light switches off the battery is fully charged, and the product is ready for use. When charging for the first time, please allow 8 hours minimum.

Operation instruction

1. The product has dual speed, press switch once for standard, a second time for high speed and a third to turn off. When the product is in use, the switch indicator lights continuously, when the light starts to flash the battery is nearly exhausted. If there is no suction or the motor is not rotating, then the battery needs to be charged.

NOTE: It is important to keep your Zest charged. To maintain battery longevity the battery must be kept over a pre-determined voltage.

2. When using the motorized brush for cleaning, as shown in Fig.3, press the switch button 1 or switch button 2, and the vacuum cleaner will start to work.
3. Hold the handle and adjust the angle of use to which is most comfortable for you. The motorized brush has a swivel head which means it is highly maneuverable. This can be used to clean hard floors and carpet.



Fig.3

Operation instruction in handheld mode

1. First remove the handheld unit from the upright case by pressing the handheld release buttons and lifting the handheld unit free of the main body. The handheld unit can be used separately for quick clean up jobs or together with any of the attachments supplied for more specific cleaning areas such as upholstery and chair crevices, desktop, tablecloth, curtains, inside the car, computer keyboard etc.
2. The included extension tubes provided extended reach for easy cleaning in stairwells, or other hard to reach places.



Fig.4

Emptying the waste chamber & cleaning

The handheld unit is fitted with the dust chamber and filters in place, so to disassemble the unit follow the instructions below to empty the waste chamber and clean the filters. The dust chamber is removed by pressing the button on the underside of the dust chamber. This can now be lifted and pulled away from the rest of the unit. When refitting the dust chamber, ensure the base of the chamber is fitted under the ridge cover of the motor unit and then push down into place. You should hear a “click” which means this is now secure.

To remove dust chamber from the handheld unit:

1. Press on the dust chamber release button.
2. Pull and lift the dust chamber away from the handheld unit.

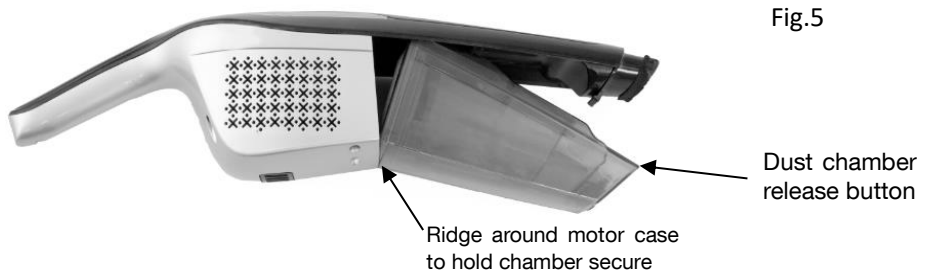

To empty dust chamber:

1. Pull colored tab to remove micro filter.
2. Lift handle on metal filter and ensure the metal filter arrow is in the locked position.
3. The filter and cyclone assembly can then be removed and the dust chamber emptied.

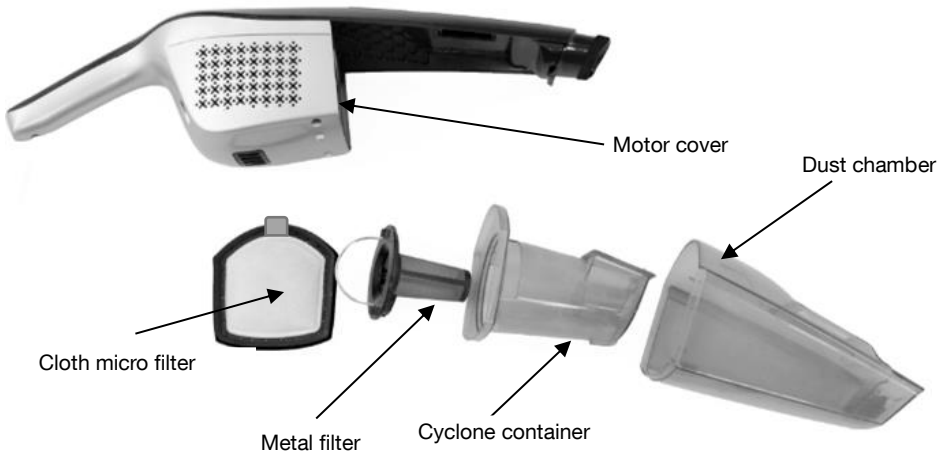
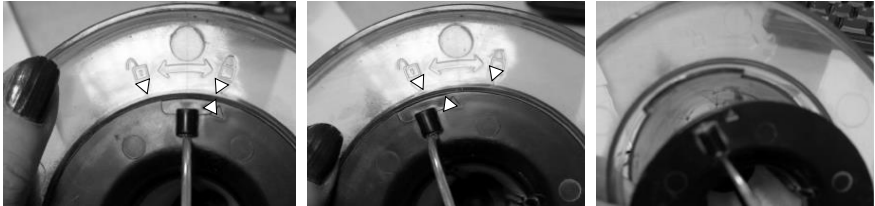

Fig.6

To clean the metal filter and cyclone container:

1. Lift the handle on the metal filter and turn arrow to the unlocked position as shown on the cyclone container.
2. Remove the metal filter from the cyclone container for cleaning. All parts must be dry before re-use.



1. Locked position

2. Unlocked position

3. Removal of metal filter

Fig.7

Air freshener inserts assembly / use

To give your home a clean fresh fragrance while vacuuming, Ewbank fragranced filter inserts are available for your Zest, simply remove the chosen fragranced filter inserts from the plastic sleeve and insert as directed into the metal basket filter before refitting the assembled dust chamber.

We recommend washing your hands after handling the fragranced filter inserts.



Fig.8

Cleaning and Maintenance

Separate the filter/waste chamber into the component parts and empty the dust chamber.

Fig.9



Warm soapy water can be used for the plastic/metal parts. ALL filter and cyclone parts must be completely dry before re-use.

We recommend the dust chamber is emptied before the level of dirt reaches the max scale line on the outer waste chamber.

Operating the unit with a full waste chamber can cause damage to the motor and voids the warranty.

Cleaning

1. Cloth micro filter. This can be gently brushed or tapped to remove dirt. Alternatively if the filter is very dirty it may be washed by hand in warm water and allowed to dry naturally. It must be completely dry before re-use. The colored tab must be facing you when re-inserted for ease of removal.
We recommend replacing the cloth micro filter every six months with normal use. Part Number EB0885

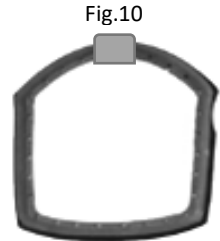
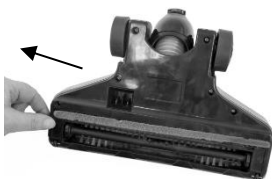

Fig.10

2. Brush roll. Should the brush roll stop rotating when the unit is in use and the battery is fully charged then the brush will need to be cleaned of hair and other debris.
 - Switch off the product and release the brush roll cover.
 - Remove the brush roll from the case.
 - Carefully use the cleaning brush with cutter included or scissors to clean the brush roll and remove hair or debris.
 - After cleaning the brush roll, fix this back into the motorized brush case and then close the cover to secure the brush roll into the main body.



Release brushroll cover

Fig.11

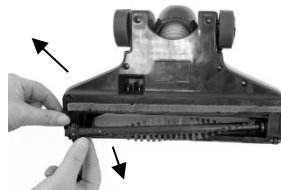

Remove brushroll and clean of trapped debris

Troubleshooting

Fault	Reason	Treatment
The unit isn't working	The battery is not charged or has cut out due to reaching its minimal voltage	Charge the battery. When charging the neon light behind the on/off switch 1 and 2 flashes. Check the charger unit is not damaged and plugged into charging station
The brush roller isn't working	Some objects are entangled in the brush roller	Take out the motorized brush and clean the objects from the brush roller as described on page 11
The brush roller still isn't working	No electrical connection between unit and motorized floor brush	Make sure floor brush is properly connected, clean and the locking clip is secured.
Charger indicate light is not lit	Power plug is not inserted into the socket	Insert the plug into socket

After-sales service

If you experience any quality issues please contact our Quality Department toll free on 855-439-2265. For further information on this product and viewing the product in use, please visit our website: www.ewbankus.com

Disposal of battery

Remove the built-in rechargeable battery before disposal of the product. Please make sure that the batteries are disposed of at an officially assigned location, it should not be mixed with general household waste. The product must be disconnected from the electricity supply before removing the batteries.

Procedure to remove the battery before disposal of the unit

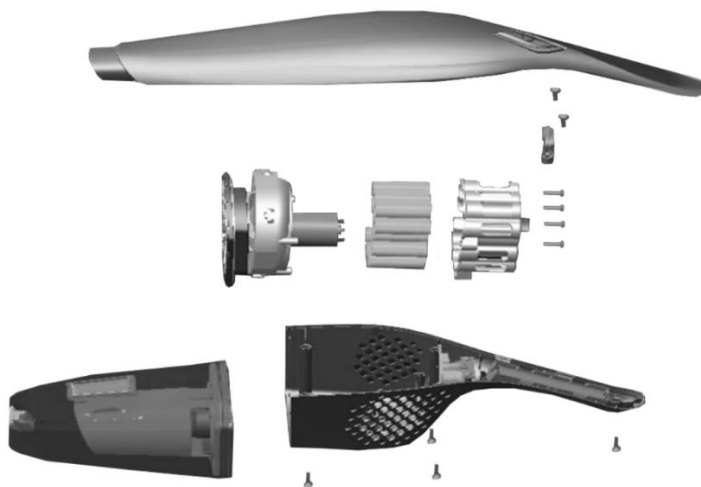

Fig.12

Use of Accessories



Fig.13

Accessories and Spares

To keep your Zest in best working condition and to maintain fragrance during operation you will need to purchase replacement parts. These are available either from your dealer or direct from us at www.ewbankus.com

Fragranced Air Freshener Inserts

We currently offer two fragrance varieties – Fresh Cotton or Vanilla Zest. These are supplied in packs of 6 of each fragrance or a mixed pack with three of each.

EB0940 – Pack of 6 Fresh Cotton

EB0941 – Pack of 6 Vanilla Zest

EB0942 – pack of 3 Fresh Cotton & 3 Vanilla Zest

Replacement Filter

To give the very best filtration the filter needs replacing from time to time. This obviously depends on the amount of use but on average it is recommended that the filter is replaced every 6 months.

EB0885 – Replacement Filter

Please visit our website to find the latest information and updates plus helpful videos to get the best from your Zest.

Your Warranty

This product is guaranteed for a period of 12 months against faulty materials and workmanship. While every possible care is taken by Ewbank LLC to ensure that our products leave the factory in good working order, Ewbank LLC cannot under any circumstances accept liability for problems or damage caused by their subsequent use. It is the responsibility of the user to ensure the surfaces to be treated or cleaned are suitable for polishing. This warranty does not affect your statutory rights. This warranty excludes the use for rental. In the event of a fault occurring please contact our helpline before returning the unit to our Service Department at the address below together with a copy of your purchase receipt. All repairs will be dealt with speedily. Some States do not allow limitations on how long an implied warranty lasts and some States do not allow the exclusion or limitation of incidental or consequential damages, so part or all of the above limitations or exclusions may not apply to you. This warranty gives you specific legal rights, and you may also have other rights which vary from state to state.

Phone: 855-439-2265

www.ewbankus.com

Made in PRC

EB0913 0517