

OPERATOR'S MANUAL

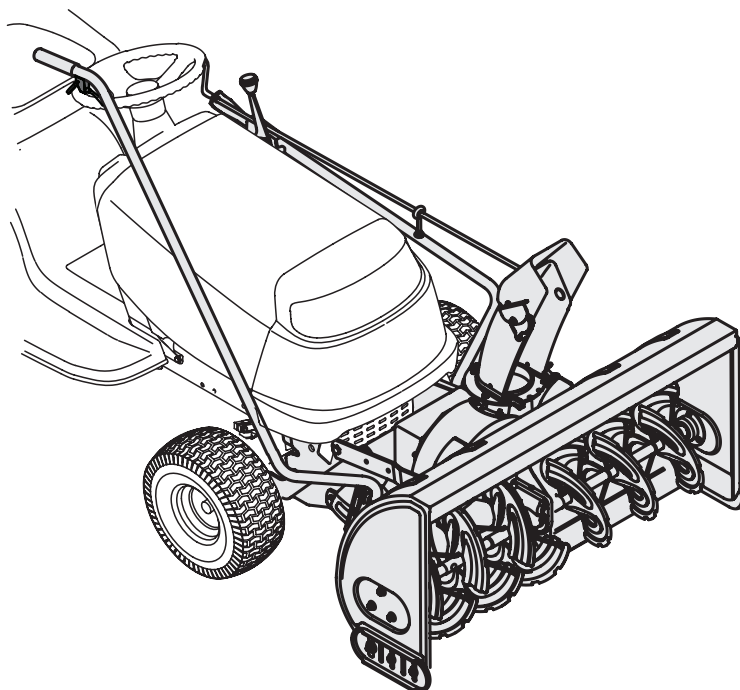

Two-Stage Snow Thrower Attachment — 190-032

⚠ WARNING

**READ AND FOLLOW ALL SAFETY RULES AND INSTRUCTIONS IN THIS MANUAL
BEFORE ATTEMPTING TO OPERATE THIS MACHINE.
FAILURE TO COMPLY WITH THESE INSTRUCTIONS MAY RESULT IN PERSONAL INJURY.**

MTD LLC, P.O. BOX 361131 CLEVELAND, OHIO 44136-0019

Thank You

Thank you for purchasing an MTD snow thrower attachment. It was carefully engineered to provide excellent performance when properly operated and maintained.

Please read this entire manual prior to operating the equipment. It instructs you how to safely and easily set up, operate and maintain your machine. Please be sure that you, and any other persons who will operate the machine, carefully follow the recommended safety practices at all times. Failure to do so could result in personal injury or property damage.

All information in this manual is relative to the most recent product information available at the time of printing. Review this manual frequently to familiarize yourself with the machine, its features and operation. Please be aware that this Operator's Manual may cover a range of product specifications for various models. Characteristics and features discussed and/or illustrated in this manual may not be applicable to all models. We reserve the right to change product specifications, designs and equipment without notice and without incurring obligation.

If you have any problems or questions concerning the machine, phone your local authorized MTD service dealer or contact us directly. MTD's Customer Support telephone numbers, website address and mailing address can be found on this page. We want to ensure your complete satisfaction at all times.

Throughout this manual, all references to *right* and *left* side of the machine are observed from the operating position.

Table of Contents

Safe Operation Practices	3	Operation.....	15
Assembly & Set-Up	6	Maintenance.....	17
Controls.....	14	Illustrated Parts List	18

Record Product Information

Before setting up and operating your new equipment, please locate the model plate on the equipment and record the information in the provided area to the right. You can locate the model plate by standing at the operator's position and looking down at the rear of the auger housing. This information will be necessary, should you seek technical support via our web site, Customer Support Department, or with a local authorized service dealer.

MODEL NUMBER

--	--	--	--	--	--	--	--	--	--	--	--

SERIAL NUMBER

--	--	--	--	--	--	--	--	--	--	--	--

Customer Support

Please do NOT return the machine to the retailer or dealer without first contacting the Customer Support Department.

If you have difficulty assembling this product or have any questions regarding the controls, operation, or maintenance of this machine, you can seek help from the experts. Choose from the options below:

- ◇ Visit us on the web at www.mtdproducts.com



See How-to Maintenance and Parts Installation Videos at www.mtdparts.com/KnowledgeCenter

- ◇ Call a Customer Support Representative at (800) 800-7310 or (330) 220-4683

- ◇ Write to MTD LLC • P.O. Box 361131 • Cleveland, OH • 44136-0019

Important Safe Operation Practices

2



WARNING! This symbol points out important safety instructions which, if not followed, could endanger the personal safety and/or property of yourself and others. Read and follow all instructions in this manual before attempting to operate this machine. Failure to comply with these instructions may result in personal injury. When you see this symbol. **HEED ITS WARNING!**

CALIFORNIA PROPOSITION 65



WARNING! Engine Exhaust, some of its constituents, and certain vehicle components contain or emit chemicals known to State of California to cause cancer and birth defects or other reproductive harm.



DANGER: This machine was built to be operated according to the safe operation practices in this manual. As with any type of power equipment, carelessness or error on the part of the operator can result in serious injury. This machine is capable of amputating fingers, hands, toes and feet and throwing foreign objects. Failure to observe the following safety instructions could result in serious injury or death.

Training

1. Read, understand, and follow all instructions on the machine and in the manual(s) before attempting to assemble and operate. Keep this manual in a safe place for future and regular reference and for ordering replacement parts.
2. Be familiar with all controls and their proper operation. Know how to stop the machine and disengage them quickly.
3. Never allow children under 14 years old to operate this machine. Children 14 years old and over should read and understand the operation instructions and safety rules in this manual and should be trained and supervised by a parent.
4. Never allow adults to operate this machine without proper instruction.
5. Thrown objects can cause serious personal injury. Plan your snow throwing pattern to avoid discharge of material toward roads, bystanders and the like.
6. Keep bystanders, pets and children at least 75 feet from the machine while it is in operation. Stop machine if anyone enters the area.
7. Exercise caution while operating tractor with this attachment, especially when traveling in reverse.

Preparation

1. Thoroughly inspect the area where the equipment is to be used. Remove all door mats, newspapers, sleds, boards, wires and other foreign objects which could be thrown by the auger/impeller.
2. Always wear safety glasses or eye shields during operation and while performing an adjustment or repair to protect your eyes. Thrown objects which ricochet can cause serious injury to the eyes.
3. Do not operate without wearing adequate winter outer garments. Do not wear jewelry, long scarves or other loose clothing which could become entangled in moving parts. Wear footwear which will improve footing on slippery surfaces.
4. Adjust collector housing height to clear gravel or crushed rock surfaces.
5. Disengage all clutches and shift into neutral before starting the engine.
6. Never attempt to make any adjustments while engine is running, except where specifically recommended in the operator's manual(s).
7. Let tractor engine and attachment adjust to outdoor temperature before starting to clear snow.

8. To avoid personal injury or property damage use extreme care in handling gasoline. Gasoline is extremely flammable and the vapors are explosive. Serious personal injury can occur when gasoline is spilled on yourself or your clothes which can ignite. Wash your skin and change clothes immediately.
 - a. Use only an approved gasoline container.
 - b. Never fill containers inside a vehicle or on a truck or trailer bed with a plastic liner. Always place containers on the ground, away from your vehicle, before filling.
 - c. When practical, remove gas-powered equipment from the truck or trailer and refuel it on the ground. If this is not possible, then refuel such equipment on a trailer with a portable container, rather than from a gasoline dispenser nozzle.
 - d. Keep the nozzle in contact with the rim of the fuel tank or container opening at all times, until refueling is complete. Do not use a nozzle lock-open device.
 - e. Extinguish all cigarettes, cigars, pipes and other sources of ignition.
 - f. Never fuel machine indoors.
 - g. Never remove gas cap or add fuel while the engine is hot or running.
 - h. Allow engine to cool at least two minutes before refueling.
 - i. Never over fill fuel tank. Fill tank to no more than ½ inch below bottom of filler neck to provide space for fuel expansion.
 - j. Replace gasoline cap and tighten securely.
 - k. If gasoline is spilled, wipe it off the engine and equipment. Move machine to another area. Wait 5 minutes before starting the engine.
 - l. Never store the machine or fuel container inside where there is an open flame, spark or pilot light (e.g. furnace, water heater, space heater, clothes dryer etc.).
 - m. Allow machine to cool at least 5 minutes before storing.
4. Do not operate machine while under the influence of alcohol or drugs.
5. Muffler and engine become hot and can cause a burn. Do not touch.
6. Exercise extreme caution when operating on or crossing gravel surfaces. Stay alert for hidden hazards or traffic. Do not carry passengers.
7. Exercise caution when changing direction and while operating on slopes.
8. Do not clear snow across the face of slopes; go up and down. Exercise extreme caution when operating on slopes. Do not attempt to clear steep slopes.
9. Plan your snow throwing pattern to avoid discharge towards windows, walls, cars etc. To avoid property damage or personal injury caused by a ricochet.
10. Never direct discharge at children, bystanders and pets or allow anyone in front of the machine.
11. Do not overload machine capacity by attempting to clear snow at too fast of a rate.
12. Never operate this machine without good visibility or light.
13. Disengage power to the auger/impeller when transporting or not in use.
14. Never operate machine at high transport speeds on slippery surfaces. Look down and behind and use care when in reverse.
15. If the machine should start to vibrate abnormally, stop the engine, disengage the power take-off, lower the attachment and set the parking brake. Inspect thoroughly for damage. Repair any damage before starting and operating.
16. After striking a foreign object, stop the engine (motor), remove the wire from the spark plug, thoroughly inspect the snow thrower for any damage, and repair the damage before restarting and operating the snow thrower.
17. Disengage the power take-off, lower attachment, set the parking brake and stop engine before you leave the operating position. Wait until the auger/impeller comes to a complete stop before unclogging the discharge chute, making any adjustments, or inspections.
18. Do not carry passengers.
19. Use only attachments and accessories approved by the manufacturer (e.g. wheel weights, tire chains, cabs etc.).
20. If situations occur which are not covered in this manual, use care and good judgment. Contact your dealer or telephone 1-800-800-7310 for assistance and the name of your nearest servicing dealer.

Operation

1. Do not put hands or feet near rotating parts, in the auger/impeller housing or discharge chute. Contact with the rotating parts can amputate hands and feet.
2. Never operate with a missing or damaged discharge chute. Keep all safety devices in place and working.
3. When cleaning, repairing or inspecting the snow thrower, make certain the collector/impeller and all moving parts have stopped. Disconnect the spark plug wire and keep the wire away from the plug to prevent someone from accidentally starting the machine. Do not run the engine indoors, except when starting the engine and for transporting the snow thrower in or out of the building. Open the outside doors; exhaust fumes are dangerous.

Clearing A Clogged Discharge Chute

Hand contact with the rotating impeller inside the discharge chute is the most common cause of injury associated with snow throwers. Never use your hand to clean out the discharge chute.

To clear the chute:

1. SHUT THE ENGINE OFF!
2. Wait 10 seconds to be sure the impeller blades have stopped rotating.
3. Always use a clean-out tool, not your hands



Maintenance And Storage

1. Never tamper with safety devices. Check their proper operation regularly.
2. Disengage power take-off, lower the attachment, set the parking brake, stop engine and remove key to prevent unintended starting. Wait until the auger/impeller comes to a complete stop before cleaning, repairing, or inspecting.
3. Check bolts, and screws for proper tightness at frequent intervals to keep the machine in safe working condition. Also, visually inspect machine for any damage.
4. Do not change the engine governor setting or over-speed the engine. The governor controls the maximum safe operating speed of the engine.

5. Snow thrower shave plates and skid shoes are subject to wear and damage. For your safety protection, frequently check all components and replace with original equipment manufacturer's (O.E.M.) parts only. "Use of parts which do not meet the original equipment specifications may lead to improper performance and compromise safety!"
6. Check clutch controls periodically to verify they engage and disengage properly and adjust, if necessary. Refer to the PTO and safety interlock system in your tractor's operator's manual for instructions.
7. Maintain or replace safety and instruction labels, as necessary.
8. Observe proper disposal laws and regulations for gas, oil, etc. to protect the environment.
9. Prior to storing, run machine a few minutes to clear snow from machine and prevent freeze up of auger/impeller.
10. Never store the machine or fuel container inside where there is an open flame, spark or pilot light such as a water heater, furnace, clothes dryer etc.
11. Always refer to the operator's manual for proper instructions on off-season storage.

Safety Symbols

The safety symbols below may appear on this product. Read, understand, and follow all instructions on the machine before attempting to assemble and operate.

Symbol	Description
	WARNING— ROTATING BLADES Keep hands out of inlet and discharge openings while machine is running. There are rotating blades inside
	WARNING— ROTATING AUGER Do not put hands or feet near rotating parts, in the auger/impeller housing or chute assembly. Contact with the rotating parts can amputate hands and feet.



WARNING! Your Responsibility—Restrict the use of this power machine to persons who read, understand and follow the warnings and instructions in this manual and on the machine.

SAVE THESE INSTRUCTIONS!

Contents of Carton

- One Auger Housing Assembly
- One Lift Handle Assembly
- One Hardware Pack
- One Upper Chute Crank Rod
- One Undercarriage Assembly
- Operator's Manual
- Two Self-adhesive Reflectors

Contents of Hardware Pack

- Two Quick Release Pins
- Three Cable Ties
- One Short Extension Spring
- Two Shoulder Bolts & Lock Nuts
- One Long Extension Spring



WARNING! Before installing attachment, place tractor on a firm and level surface. Place the PTO in the disengaged (OFF) position, set the parking brake, shut engine off and remove key to prevent unintended starting.

NOTE: References to LEFT and RIGHT indicate the left and right sides of the tractor when facing forward in the operator's position. Reference to the FRONT indicates the grille end; to the REAR the drawbar end.

Several components on your tractor must be removed prior to mounting the snow thrower attachment. Refer to Deck Removal in your tractor's Operator's Manual for detailed instructions. If your tractor is equipped with any front-end accessory (i.e. front bumper kit), it must also be removed.

Assembly

If you engage your tractor's cutting deck by using your right hand to pivot a lever forward, your tractor has a **Manual PTO**. If you engage your tractor's cutting deck by pulling outward on a small knob located on the tractor's dash, your tractor has an **Electric PTO**. Follow applicable instructions.

Models with an Electric PTO

1. Attach one end of the short extension spring (found in the hardware pack) to the hole in the idler assembly. Mount the opposite end of the extension spring to the slotted fitting as illustrated in Figure 3-1.

Models with a Manual PTO

1. Position the undercarriage on the floor beneath your tractor close to the PTO cable. The small idler pulley should be pointed towards the front of your tractor.
2. Attach the spring on the end of the PTO cable to the idler bracket, then fit the cable into the slotted fitting and secure it in place with the hairpin clip as shown in Figure 3-2.

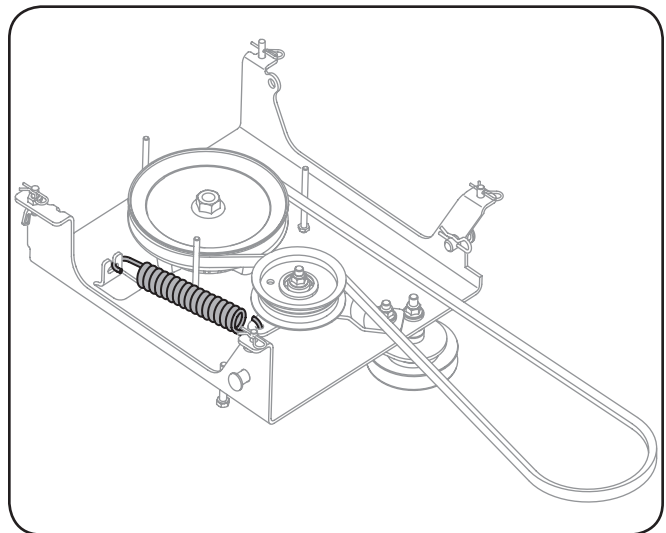

Figure 3-1

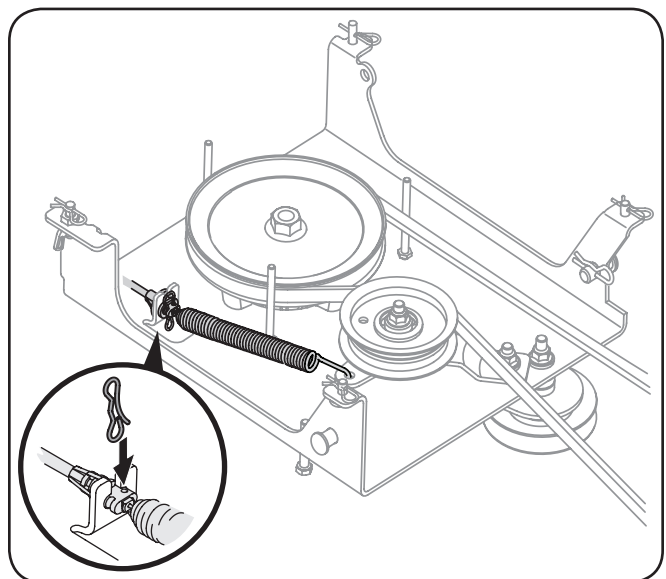

Figure 3-2

Mounting The Undercarriage Assembly

Refer to the Model Plate found on the underside of your tractor's seat to identify it as either a 700-series or a 900-series. If the fifth digit of the model number is a 7, the tractor is a 700-series. If the fifth digit of the model number is a 9, the tractor is a 900-series. Follow applicable instructions.

700-and 900-Series

1. Remove the pin and wing nut at the right rear of the undercarriage assembly. See Figure 3-3.

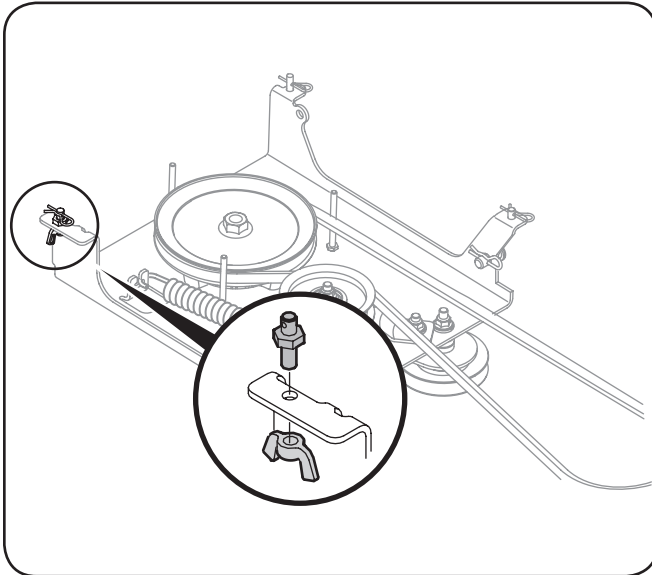

Figure 3-3

2. Remove and retain the four hairpin clips from the weld pins found on the top side of the undercarriage assembly. Remove and retain the two clevis pins with hairpin clips. This hardware is for later installation. Figure 3-4.

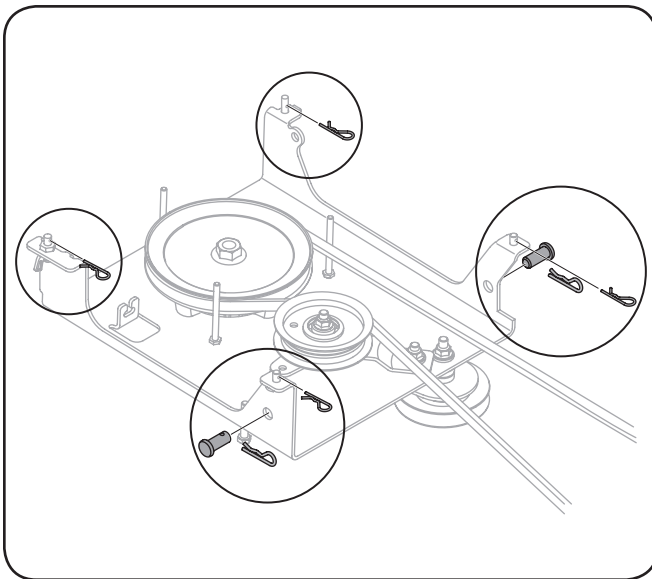

Figure 3-4

IMPORTANT: It will be helpful to have a second person (or a hydraulic floor lift) to assist you to complete steps 3 through 6.

700-Series

3. Place the undercarriage assembly beneath the tractor and lift it up against the frame of the tractor. See Figure 3-5.

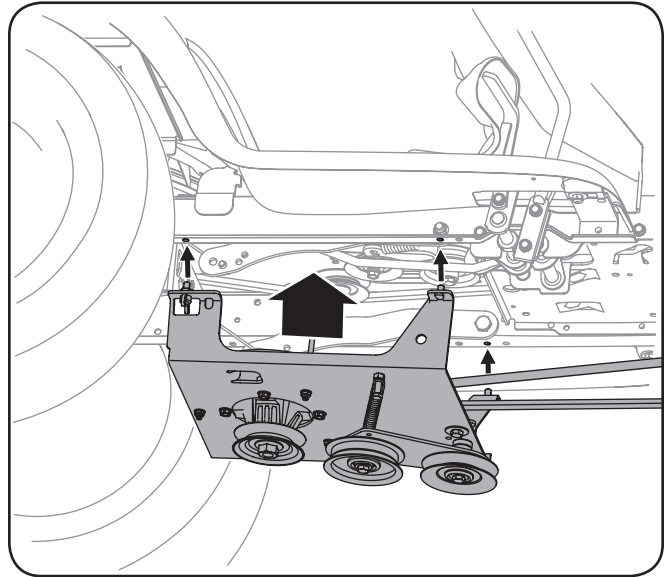

Figure 3-5

4. Insert the weld pins found on the top of the undercarriage assembly into the aligning holes found along the tractor's frame. Secure the undercarriage assembly to the frame with the four hairpin clips removed earlier. See Figure 3-6.

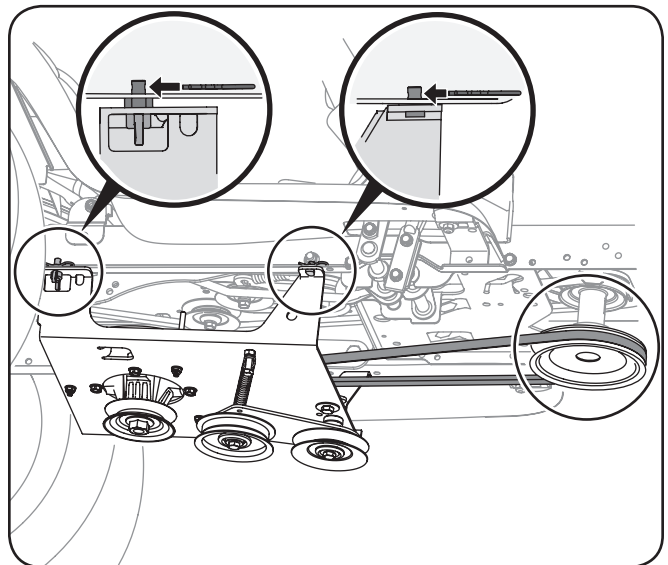

Figure 3-6

5. Route the upper drive belt around the engine pulley. See Figure 3-6.

Note: If your tractor had a belt keeper rod around the engine pulley that you removed while taking the tractor's deck off, reinstall it at this time.

- Attach one end of the long extension spring (found in the hardware pack) to the idler pulley bracket and the other end to the tractor's frame rail. See Figure 3-7 and Figure 3-8.

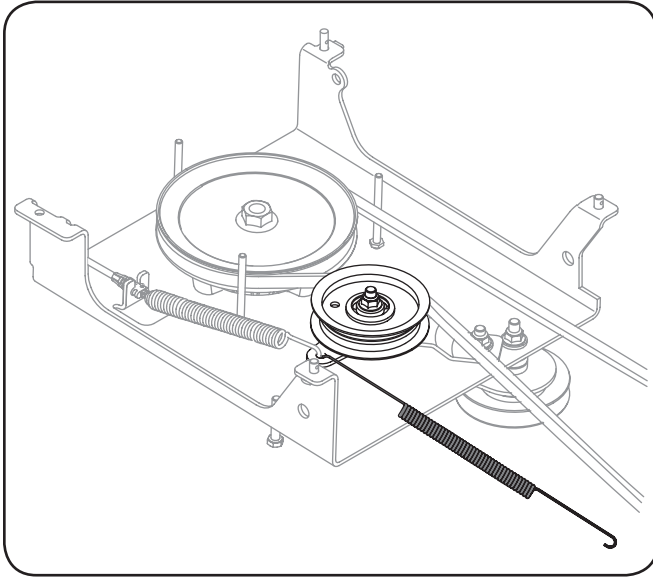

Figure 3-7

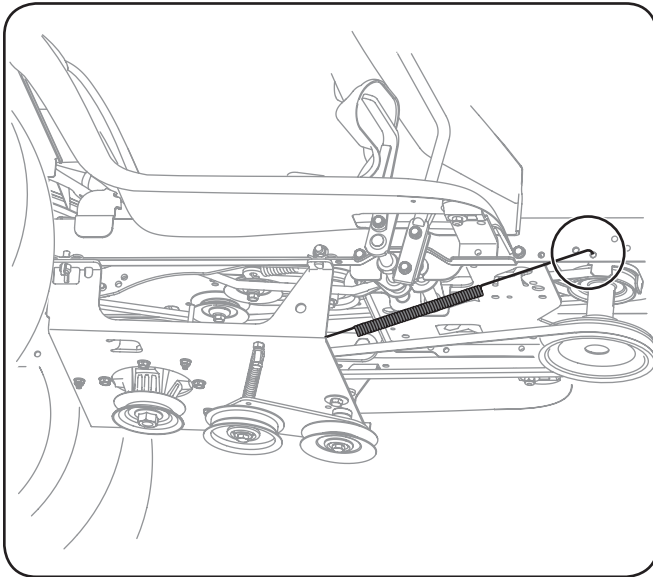

Figure 3-8

900-Series

Some 900-series tractors have a deck anti-sway rod that must be removed prior to mounting the snow thrower undercarriage.

- Remove the shoulder bolt and flange nut that secures the left deck lift arm to the tractor's frame. Remove the flange nut that secures the anti-sway rod to the left deck lift arm. See Figure 3-9.
- The right side of the anti-sway rod is secured by either a hairpin clip or a flange nut. Remove whichever is present and store the anti-sway rod and hardware in a safe place. See Figure 3-10.

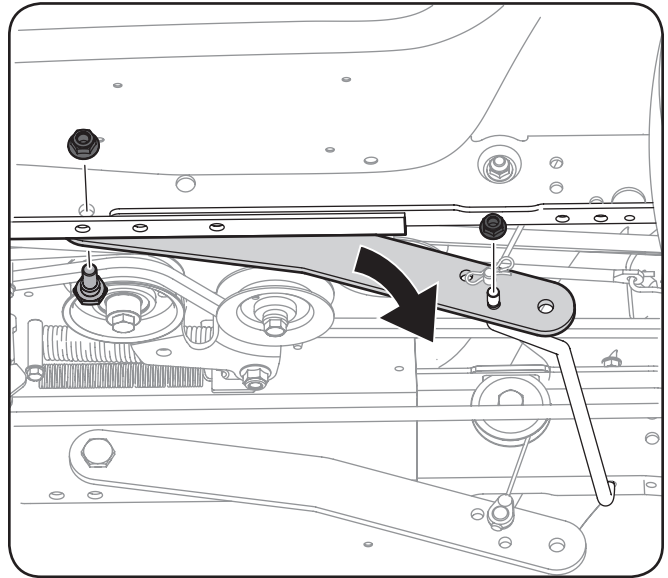

Figure 3-9

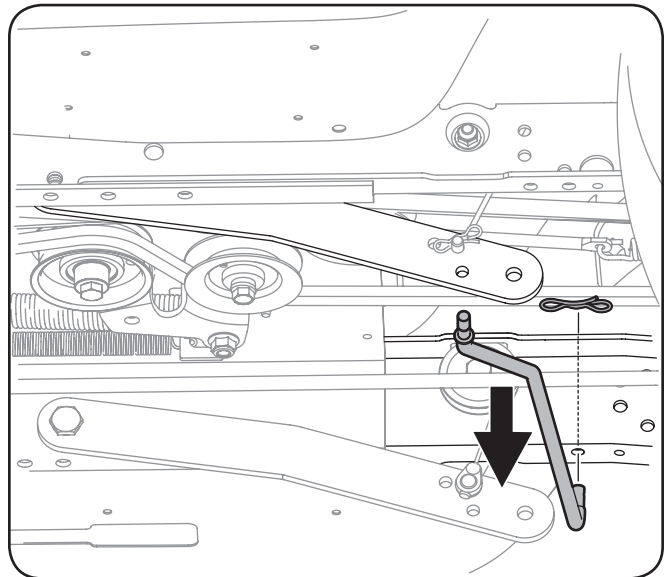

Figure 3-10

9. Place the undercarriage assembly beneath the tractor and lift it up against the frame of the tractor. See Figure 3-11.
10. Insert the weld pins found on the top of the undercarriage assembly into the aligning holes found along the tractor's frame. Secure the undercarriage assembly to the frame with the four hairpin clips removed earlier. See Figure 3-12.

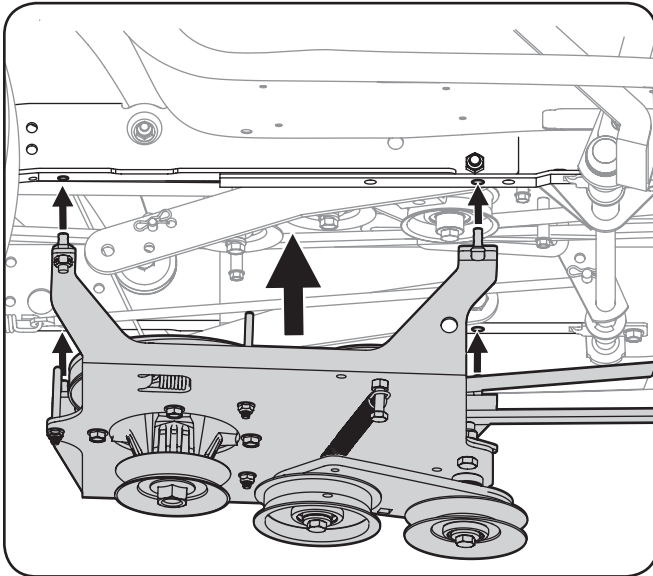

Figure 3-11

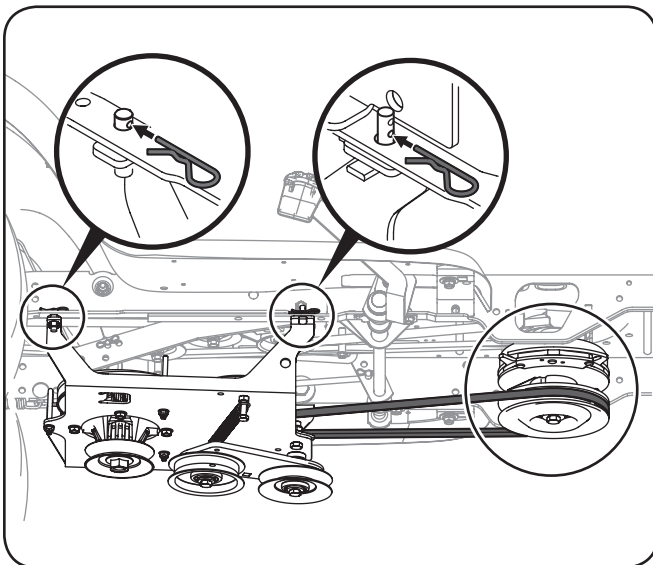

Figure 3-12

11. Route the upper drive belt around the electric PTO clutch (or engine pulley on manual PTO models). See Figure 3-12.

Note: If your tractor had a belt keeper rod around the engine pulley that you removed while taking the tractor's deck off, reinstall it at this time.

12. Attach one end of the long extension spring (found in the hardware pack) to the idler pulley bracket and the other end to the tractor's frame rail. See Figure 3-13 and Figure 3-14.

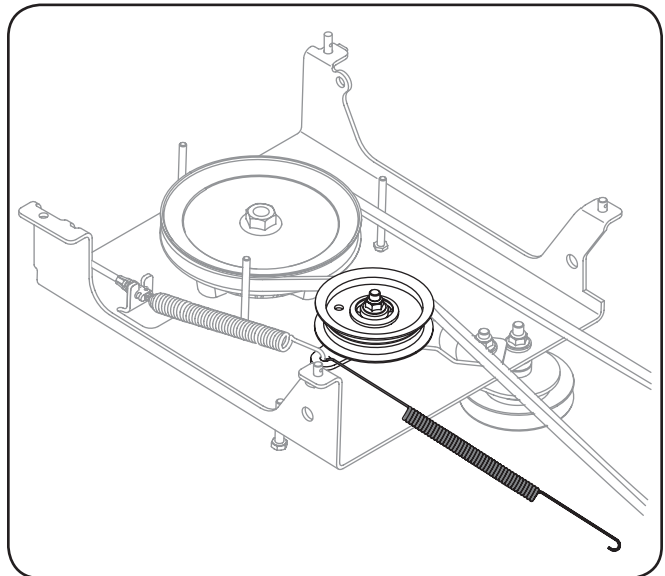

Figure 3-13

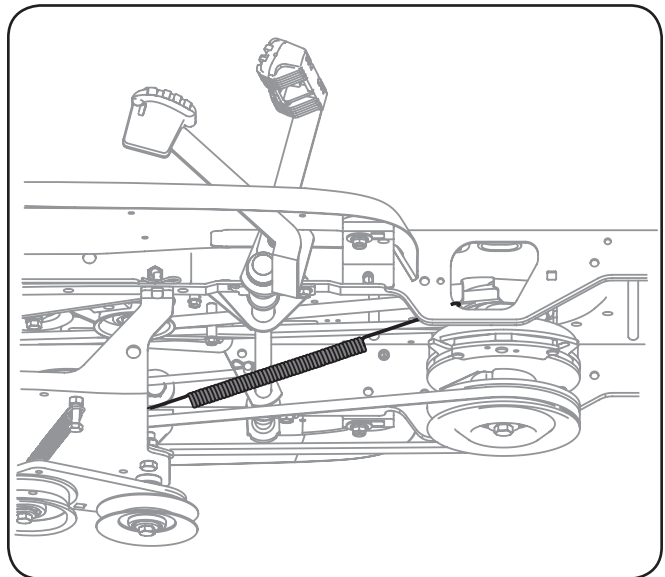

Figure 3-14

Attaching The Chute Directional Control

1. Attach the chute directional control assembly to the upper lift link on the left side of the auger housing. Assemble with two hex screws and two saddle washers as shown in Figure 3-15. Secure with two flange nuts.

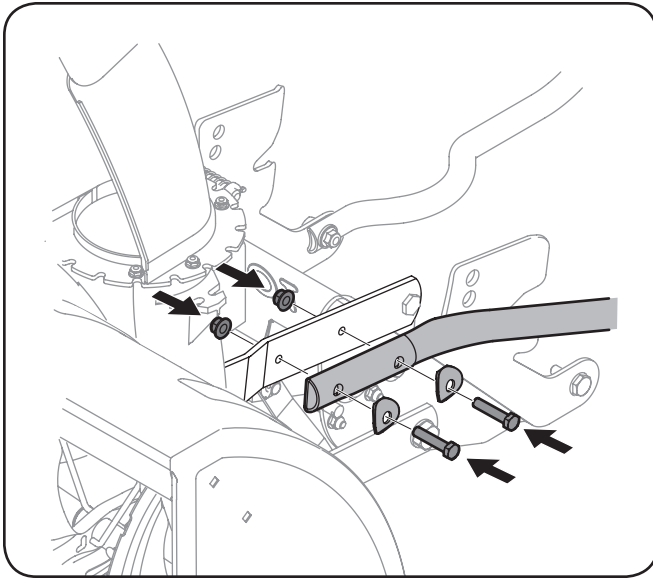

Figure 3-15

2. Secure the upper chute crank rod (A) to the joint block on the lower chute crank rod with the cotter pin (B) provided. See Figure 3-16.

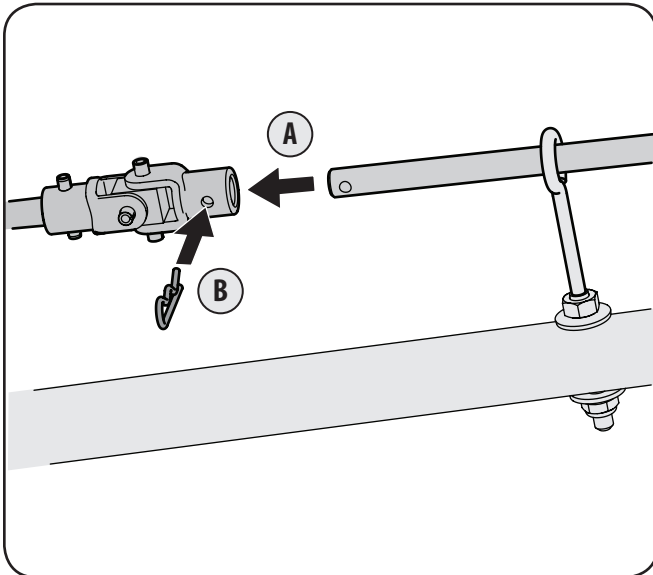

Figure 3-16

3. Fasten chute tilt cables to chute directional control with two of the cable ties provided. Pull cable ties until snug and trim excess.

Attaching The Lift Handle

1. Attach lift handle to lift bracket on the right side of auger housing assembly with two hex screws and two flange nuts provided. See Figure 3-17.

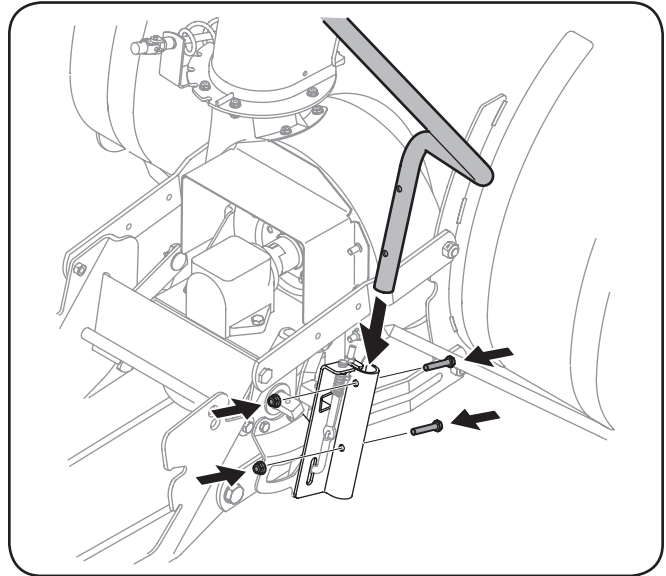

Figure 3-17

2. Fasten the lift cable to the lift handle with two of the cable ties provided. Pull the cable ties until snug and trim excess.

Mounting The Auger Assembly

IMPORTANT: It will be necessary to have a second person assist you to complete the following steps.

1. Install a shoulder bolt (found in the hardware pack) on each side of the tractor's front end and secure with a lock nut. See Figure 3-18.

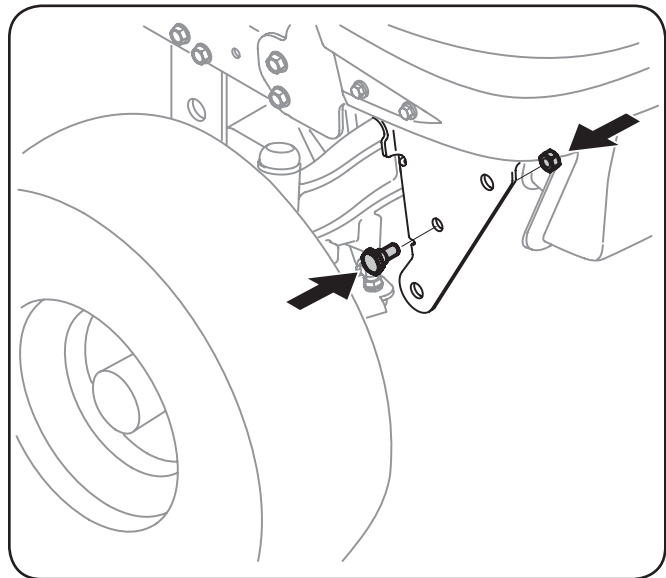

Figure 3-18

- Position the auger housing assembly in front of the tractor. See Fig. 3-15. Lay the belt and support tubes on the installation surface.

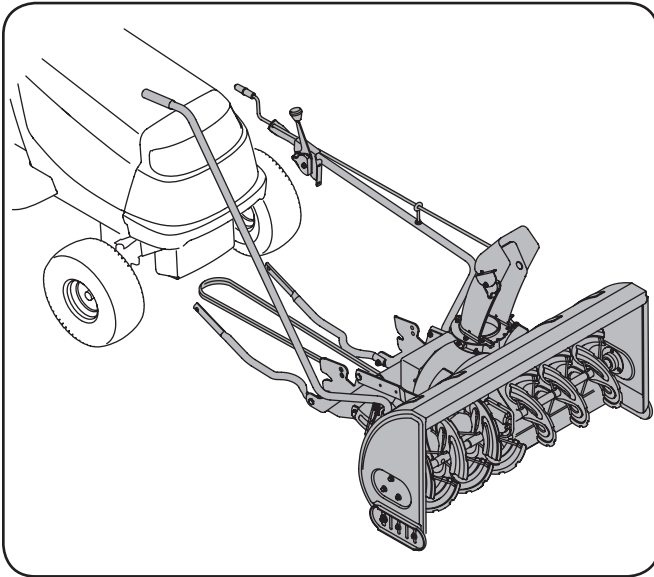

Figure 3-19

- Carefully move the tractor forward (by pushing, NOT driving it) so that support tubes found on the rear of the auger housing assembly are positioned between the tractor's front tires. Set the parking brake.
- With the help of an assistant, lift up the auger housing and move it so that it rests over the shoulder bolts installed in Step 1 of this section. See Figure 3-20.

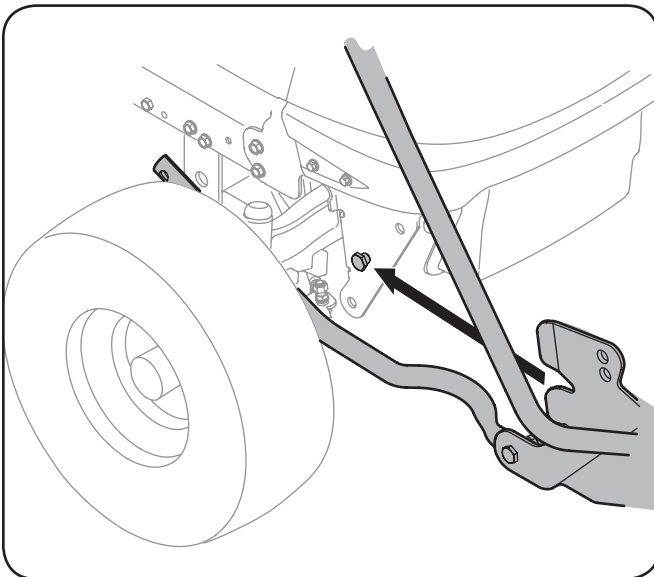

Figure 3-20

- Maneuver the auger housing until the mounting holes line up. Insert the two quick release pins from your hardware pack into the top hole on each side as shown in Figure 3-21.

NOTE: You will need to lift up on the front of the auger housing in order to line up the holes.

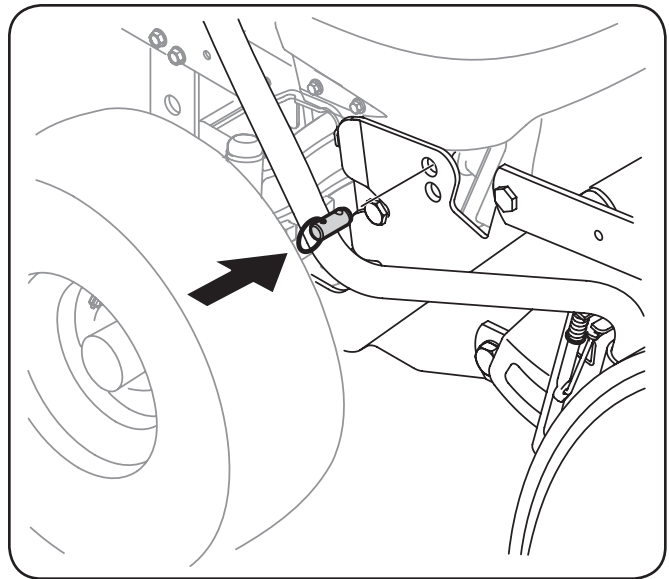

Figure 3-21

Attaching Support Tubes

- Secure the left support tube to the front of the undercarriage assembly with the clevis pin and hairpin clip removed earlier in step 2 of the mounting the undercarriage assembly section. See Figure 3-22.
- Repeat the previous step on the right side.

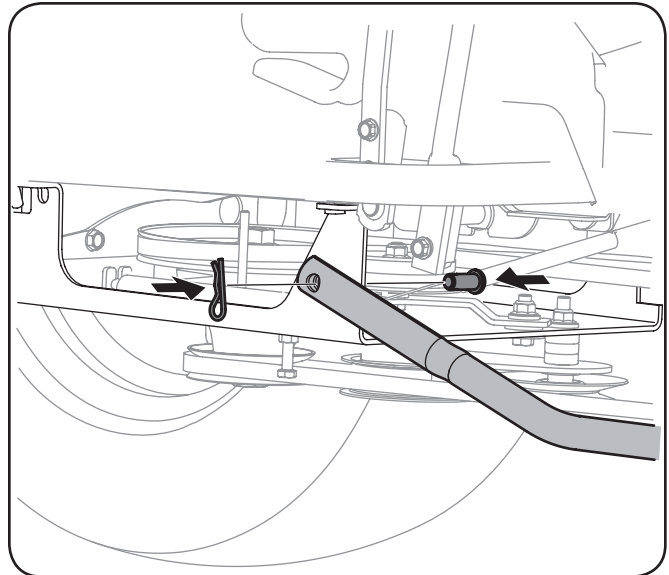

Figure 3-22

Attaching Reflectors

Peel off the backing from each of the reflectors to expose the adhesive surface. Adhere the reflectors to the rear of the tractor's fender (one on the left and one on the right) so that the reflectors simulate taillights.

Routing the Lower Drive Belt (All Tractor Models)

1. Route the lower drive belt around the lower pulley on the spindle assembly, both pulleys on the double-idler bracket found beneath the undercarriage, and the drive pulley found on the rear of the snow thrower housing as illustrated below.

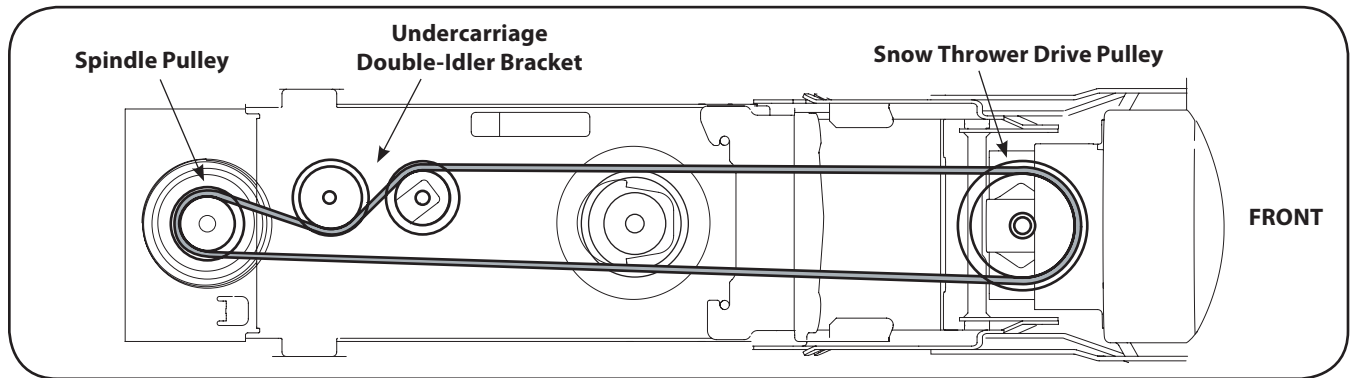

Set-Up

Shear Pins

A pair of replacement auger shear pins and bow tie cotter pins are included with your snow thrower. Store them in a safe place until needed.

Skid Shoe Adjustment



WARNING! Never attempt to make any adjustments while the engine is running, except where specified in the Operator's Manual. Place tractor on a firm and level surface. Place the PTO in the disengaged (OFF) position, set the parking brake, shut engine off, and remove key to prevent unintended starting.

The snow thrower skid shoes are adjusted upward at the factory for shipping purposes. Adjust them downward, if desired, prior to operating the snow thrower.



CAUTION: It is not recommended that you operate this snow thrower on gravel as it can easily pick up and throw loose gravel, causing personal injury or damage to the snow thrower and surrounding property.

- For close snow removal on a smooth surface, raise skid shoes higher on the auger housing.
- Use a middle or lower position when the area to be cleared is uneven, such as a gravel driveway

NOTE: If you choose to operate the snow thrower on a gravel surface, keep the skid shoes in position for maximum clearance between the ground and the shave plate.

To adjust the skid shoes:

1. Loosen the four hex nuts (two on each side) and carriage bolts. Move skid shoes to desired position. See Figure 3-23.
2. Make certain the entire bottom surface of skid shoe is against the ground to avoid uneven wear on the skid shoes.
3. Retighten nuts and bolts securely.

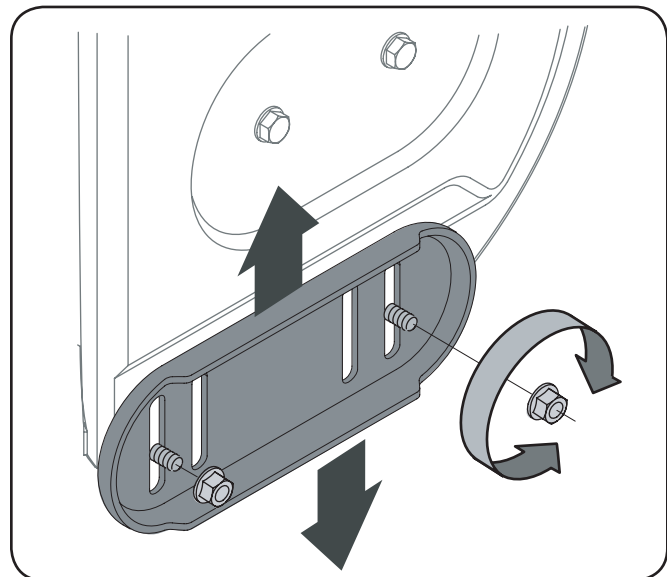

Figure 3-23

Lift Adjustment

If the lift index rod doesn't securely latch or the pivot release has too much slack in it, an adjustment can be made as follows:

1. Loosen the upper hex nut a few turns, then tighten the lower hex nut to shorten the cable length. See Figure 3-24.
2. Loosen the lower hex nut a few turns, then tighten the upper hex nut to lengthen the cable. See Figure 3-24.

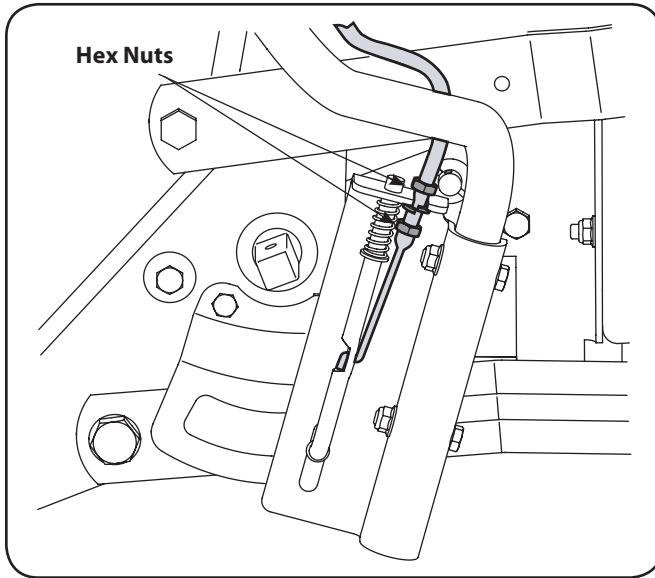

Figure 3-24

Lower Chute Crank Support Bracket Adjustment

If the spiral at the base of the lower chute crank isn't fully engaging with the notches in the lower chute assembly, the support bracket can be adjusted inward or outward as follows:

1. Loosen, but do NOT remove the two hex nuts which secure the support bracket to the snow thrower housing. See Figure 3-25.

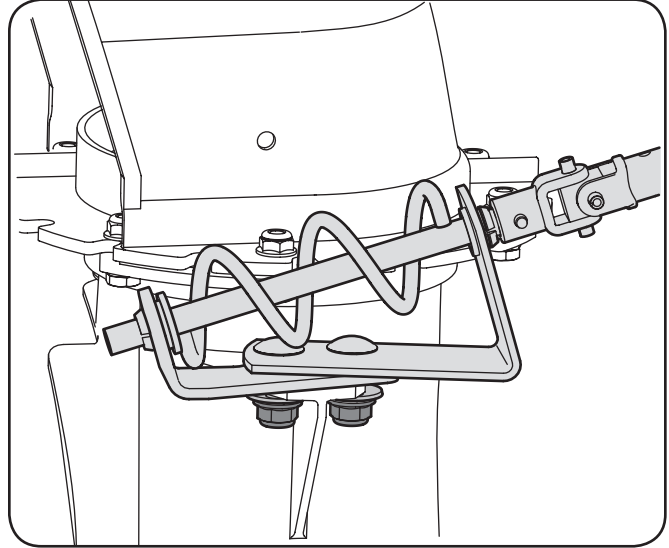
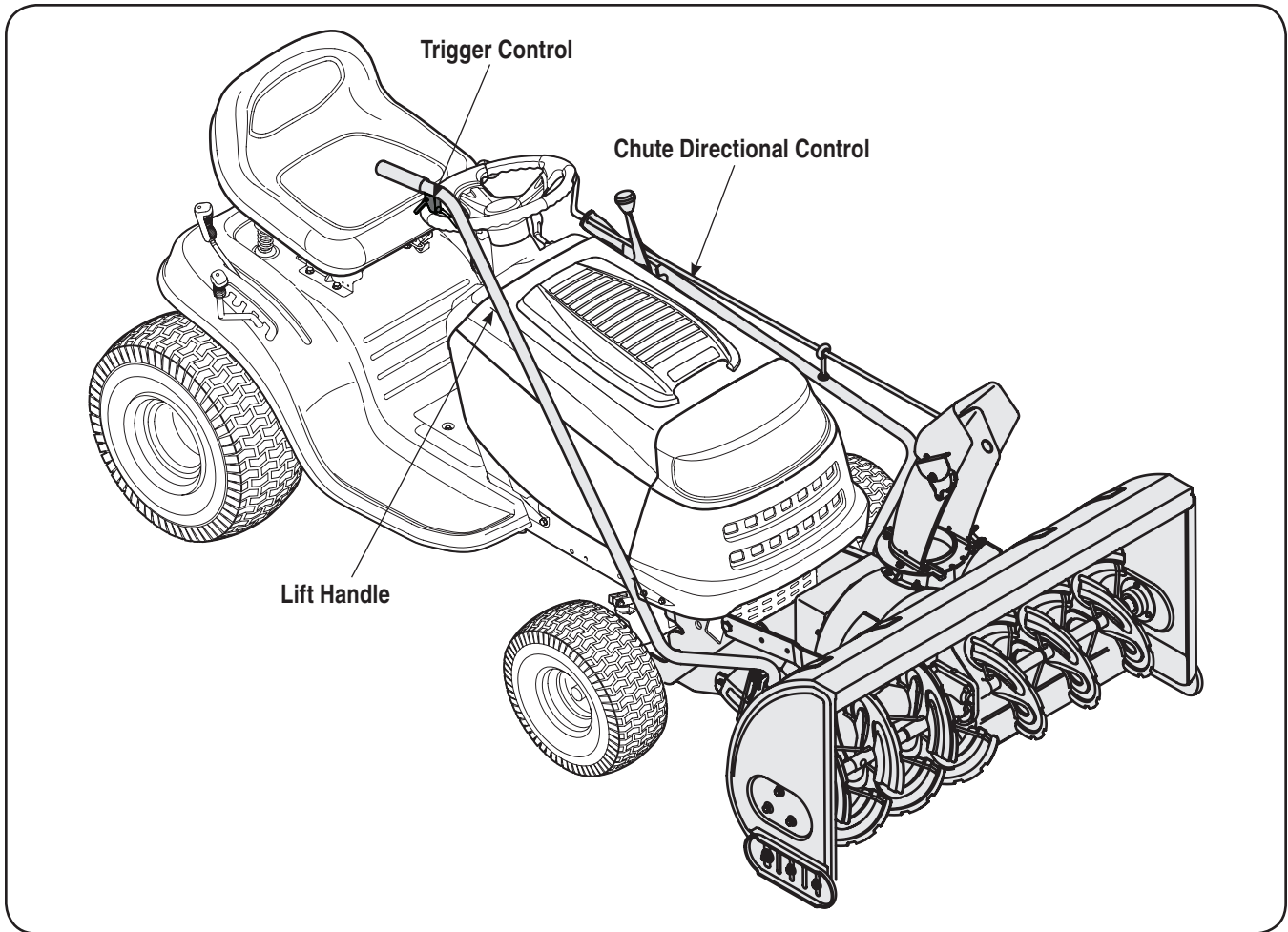

Figure 3-25

2. Adjust the support bracket inward or outward so that the spiral is fully engaged in the notches on the chute before retightening the hex nuts.



Controls



WARNING! Be familiar with all controls and their proper operation. Know how to stop the machine and disengage them quickly.

Lift Handle

The lift handle is located on the right side of the tractor and is used to raise and lower the snow thrower attachment.

1. To raise the snow thrower attachment off of the ground, pull rearward and down on the lift handle until you feel the lift latch on the right side of the snow thrower engage, locking the snow thrower in a raised position.
2. To lower the snow thrower, push downward on the lift handle until there is enough slack in the lift cable so that you may squeeze the trigger control. With the trigger control squeezed, gently allow the snow thrower to lower until it reaches the ground.

Chute Directional Control

The chute directional control assembly is found on the left side of the tractor and includes both the chute tilt lever as well as the chute crank. Both affect the direction that the discharged snow is thrown.

To pivot the upper section of discharge chute, affecting the distance and angle which the snow is thrown, move the chute tilt lever forward or rearward into a desired position.

The direction which snow is thrown can be changed by rotating the discharge chute with the chute crank. Turn the chute crank clockwise to rotate the chute and discharge snow to the left. Crank it counterclockwise to rotate the chute and discharge snow to the right.

Operation



WARNING! Read, understand, and follow all instructions and warnings on the tractor, the attachment, and in the operator's manuals before operating. Your snow thrower attachment is capable of displacing snow and clearing a path a width of 42 inches.

Observe the following operating instructions for efficient snow removal:

1. Become familiar with and comfortable using all of your tractor's controls as instructed in your tractor's Operator's Manual before operating it with the snow thrower attachment.
2. Make certain the correct weight (and volume) of motor oil is in your tractor's engine as instructed in the engine Owners Guide packed with the tractor's Operator Manual.
3. Always operate the snow thrower with the tractor's engine at maximum RPM (full throttle).
4. NEVER override any safety features on either your tractor or the snow thrower attachment.
5. Make certain that all nuts, bolts, and hardware are fastened securely and tight on both the tractor and the snow thrower attachment prior to use.
6. Make certain the snow thrower attachment is assembled properly and mounted to the tractor as instructed in this manual.
7. Test all the controls (tractor PTO, snow thrower lift handle, chute tilt lever & chute crank) for smooth operation prior to operating the snow thrower.
8. Make all adjustments (i.e. skid shoes, lift latch) before operating your snow thrower attachment. Follow the instructions in the Assembly and Setup section of this manual when doing so.
9. Engage the tractor's PTO to activate power to the augers and impeller BEFORE driving the tractor forward and into snow.
10. Keep your tractor's ground-speed slow. The slower your tractor is traveling, the more effectively the snow thrower attachment can displace snow.
11. Adjust ground speed for snow conditions and become familiar with different snow applications. Your snow thrower attachment will operate differently in wet heavy snow than it will in light, fluffy snow.
12. Overlap a previously cleared path when necessary (deep snow) so as not to overload the auger housing with snow.
13. NEVER drive the tractor into a snow bank. The snow thrower attachment is not a dozer plow. The lift linkage and/or the snow thrower drive system can be damaged as a result of "plowing" with the snow thrower attachment.
14. If the augers become jammed with a chunk of ice or a foreign object, move the PTO into the disengaged (OFF) position immediately and turn off the tractor's engine and remove the ignition key. Examine the auger area thoroughly for damage and do NOT operate the snow thrower attachment until any damage is repaired.

IMPORTANT: The augers are secured to the spiral shaft with two shear pins and hex lock nuts. If you hit a hard foreign object or an ice jam, the snow thrower is designed so that the pins may shear. Two replacement shear pins and hex lock nuts are provided for your convenience. Store in a safe place until needed. NEVER replace the auger shear pins with standard hex bolts. Any damage to the auger gearbox or other components as a result of doing so will NOT be covered by your snow thrower's warranty.

15. Whenever possible, discharge snow downwind.
16. Do NOT attempt to remove ice or hard-packed frozen snow.
17. When the tractor (with the snow thrower attachment mounted) is not in service, use the lift lever to lower the auger housing assembly to the ground to relieve strain on the tractor's front end between uses.
18. Always use tire chains and rear wheel weights on your tractor where extra traction is needed. Refer to the table to the right to determine which kits will fit your tractor.
19. Use drift cutters to aid in displacing snow through deep, drifted areas.

Engaging the Augers and Impeller

Power to the snow thrower attachment is activated by engaging the tractor's PTO.

1. Place the tractor's throttle control in the FAST (rabbit) position and allow it to remain there for efficient snow removal.
2. Move the PTO into the "ON" position to engage the augers and impeller.
3. Move the PTO into the "OFF" position to disengage the augers and impeller.

NOTE: Refer to your tractor's Operator's Manual for more information regarding your tractor's PTO and safety interlock system.

Replacing Shear Pins

The augers are secured to the spiral shaft with two shear pins and cotter pins. If the auger should strike a foreign object or ice jam, the snow thrower is designed so that the pins may shear. If the augers will not turn, check to see if the pins have sheared. See Figure 5-1.

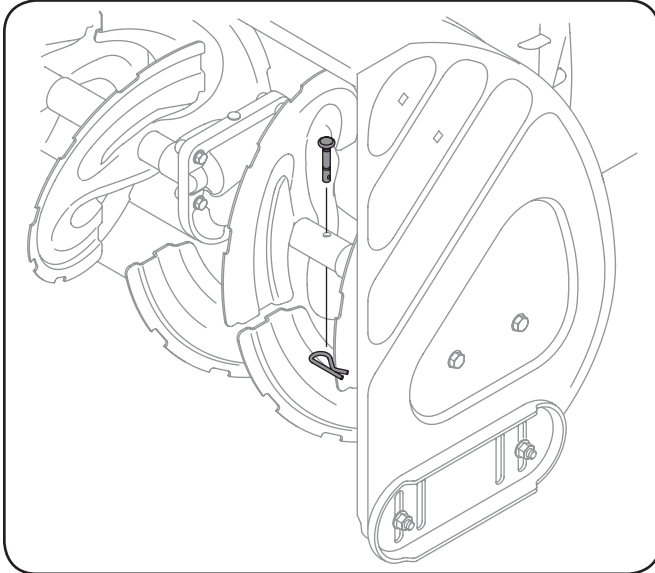

Figure 5-1



CAUTION: NEVER replace the auger shear pins with anything other than OEM Part No.738-04124A replacement shear pins. Any damage to the auger gearbox or other components as a result of failing to do so will NOT be covered by your snow thrower's warranty.



WARNING! Always turn off the snow thrower's engine and remove the key prior to replacing shear pins.

Tire Chain Kit

- 18" x 8.50" tires 490-241-0021
- 18" x 9.50" & 19" x 9.50" tires 490-241-0022
- 20" x 8.00" tires 490-241-0023
- 20" x 10.00" & 20" x 9.00 tires 490-241-0024
- 22" x 9.50" & 23" x 9.50" tires 490-241-0025
- 23" x 10.50" tires 490-241-0026

Weight Kits

- Suitcase Weight Kit 490-900-M060

Drift Cutter Kit

- Drift Cutter OEM-390-679

NOTE: None of the kits in the table are included as standard equipment with snow thrower attachment OEM-190-032 and 190-032-101. Contact the retailer in which you purchased this equipment, or utilize the contact information on page 2 of this manual for availability and information regarding these kits.



WARNING: Before lubricating, repairing, or inspecting, place tractor on a firm and level surface. Place the PTO in the disengaged (OFF) position, set the parking brake, shut engine off, and remove key to prevent unintended starting.

Lubrication of Chute Directional Control

The spiral on the end of the lower chute crank, the base of the discharge chute itself and the joint blocks which connect the lower and upper chute cranks should be lubed with multi-purpose automotive grease once a season. See Figure 6-1.

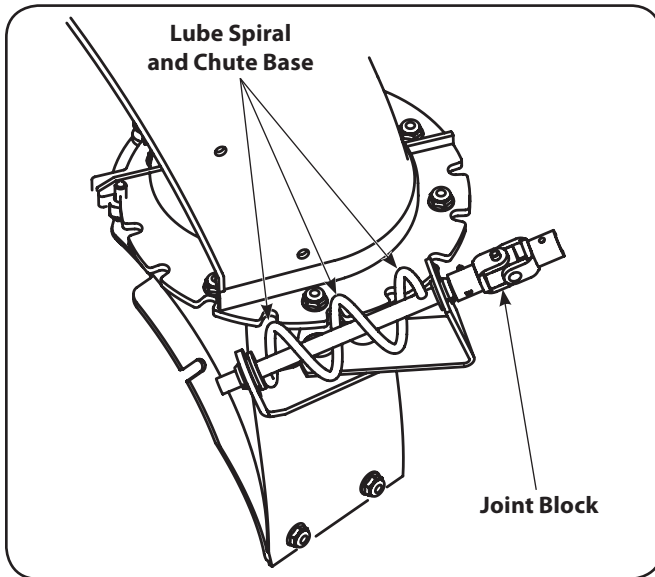

Figure 6-1

Auger Shaft

At least once a season, remove the shear bolts on the auger shaft. Oil or spray lubricant inside and on the plastic bearings on the shaft and near the holes where the shear bolts were removed before reattaching them. See Figure 6-2.

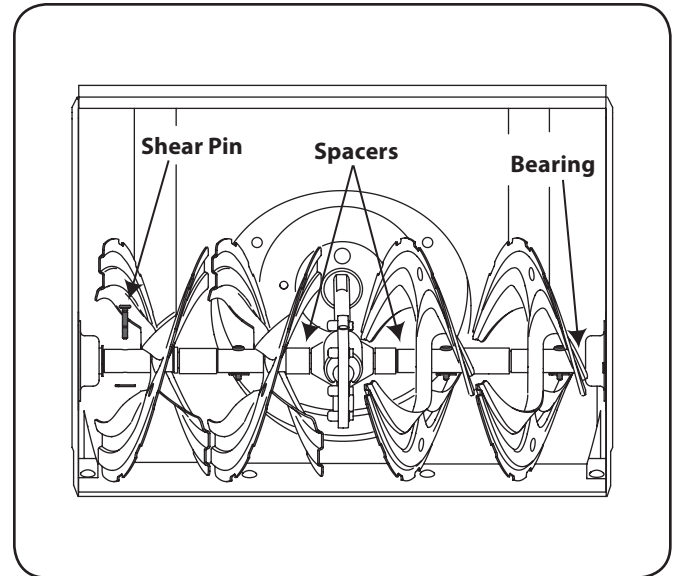
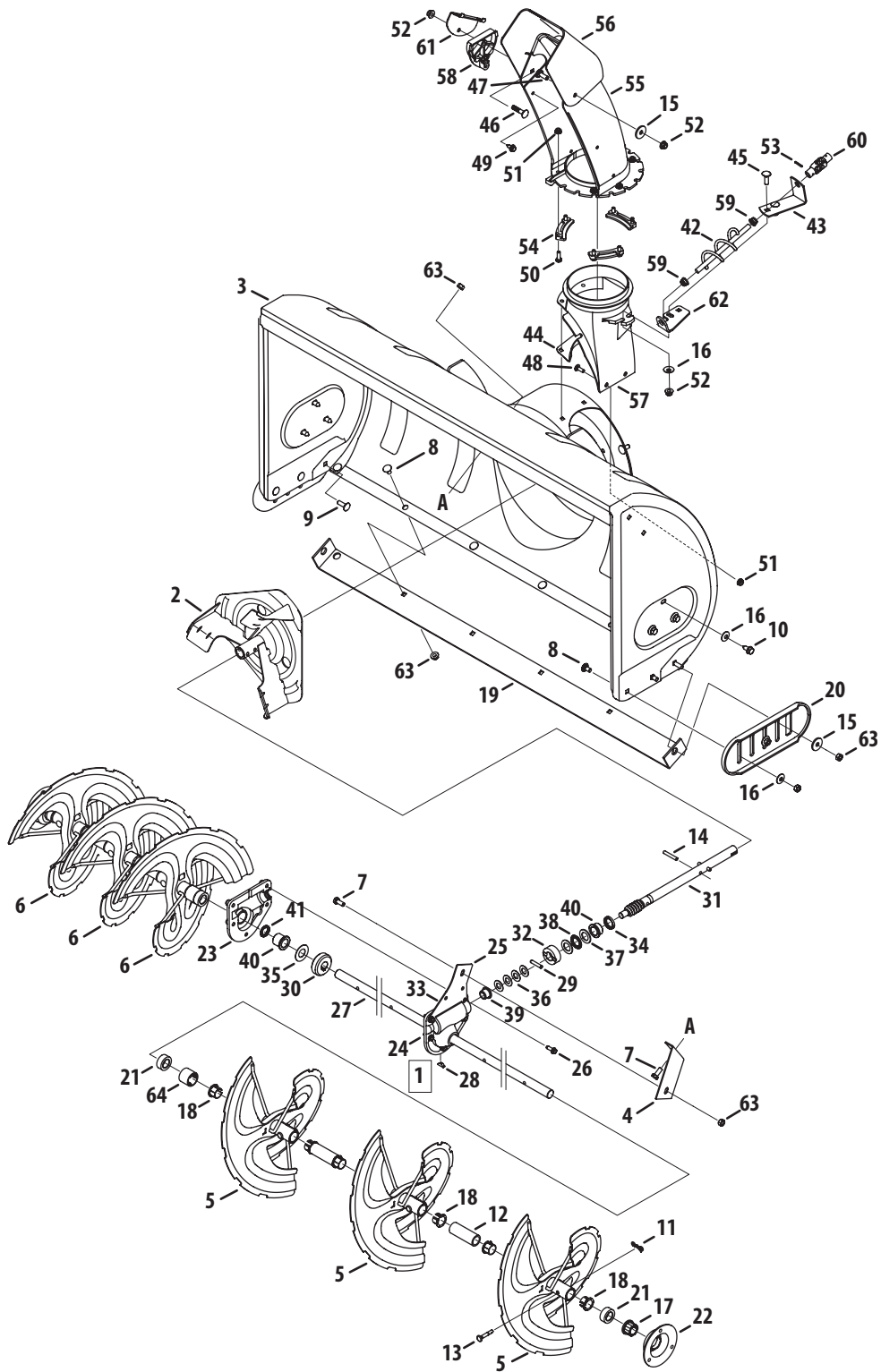

Figure 6-2

Model 190-032



Ref No.	Part Number	Description
1	918-04315	Auger Gear Box (Incl. Ref. 23-41)
2	684-0158-0637	Impeller Assembly, 12"
3	684-0148-0637	Housing Assembly
4	703-2734-0637	Housing Brace Bracket
5	684-04163-0637	LH Spiral Auger
6	684-04164-0637	RH Spiral Auger
7	710-0759	Hex Cap Screw, 5/16-18 x .625
8	710-0260A	Carriage Bolt, 5/16-18 x .62
9	710-0276	Splined Carriage Screw
10	710-04484	Self Tapping Screw
11	714-04040	Bow-Tie Cotter Pin
12	731-1086A	Sleeve .758 x 1.00 x 2.70
13	738-04124A	Shear Pin, .25 x 1.50
14	915-0114	Spirol Pin, 1/4 x 1-1/2
15	936-0231	Flat Washer, .344 x 1.125 x .12
16	736-0242	Bell Washer, .340 x .872
17	941-0245	Hex Flange Bearing, .75 ID
18	741-0493A	Flange Bushing, .80 x .91
19	784-0396B-0637	Skid Plate Bracket, 42"
20	784-5038B-0637	Slide Shoe
21	711-0469	Spacer, .75 x .125 x .5
22	784-5618A-0637	Hex Bearing Housing, 1.0
23	918-0123A	RH Reducer Housing
24	918-0124A	LH Reducer Housing
25	703-2733A-0637	Housing Brace Plate
26	710-0642	Self Tapping Screw, 1/4-20 x .75
27	711-04468	Spiral Axle, 41.5"
28	914-0161	Hi-Pro Key, 3/16 x 5/8
29	915-0143	Spring Spirol Pin, .25 x 1.25
30	917-0528A	Worm Gear, 20-tooth
31	717-3320	Worm Shaft
32	718-0513	Thrust Collar

Ref No.	Part Number	Description
33	721-0325	Grease Plug
34	721-0327	Grease Seal
35	936-0351	Flat Washer, .76 x 1.5 x .030
36	936-0369	Flat Washer, .508 x 1.0 x .020
37	736-0617	Thrust Washer, .75 x 1.25 x .0615
38	IH-324105-R92	Thrust Bearing, .75 x 1.25 x .078
39	948-0108	Flange Bearing, .503 x .75
40	741-0700	Flange Bearing, .75 x 1.0 x .59
41	921-0179	Grease Seal
42	684-0061A	Chute Crank Assembly
43	703-2735A-0637	Chute Crank Bracket
44	705-5226-0637	Chute Reinforcer
45	710-0276	Splined Carriage Screw
46	710-0262	Carriage Bolt, 5/16-18 x 1.5
47	710-04071	Carriage Screw, 5/16-18 x 1.0
48	710-0703	Screw, 1/4-20 x .75
49	710-0896	Hex Index Washer Screw
50	710-0597	Hex Cap Screw, 1/4-20 x 1.00
51	712-04064	Nylon Hex Lock Nut, 1/4-20
52	712-04063	Nylon Hex Lock Nut, 5/16-18
53	715-04095	Spirol Pin, .156 x .875
54	731-0851A	Chute Flange Keeper
55	731-1300E	Lower Chute
56	731-04427A	Upper Chute
57	731-1379D	Adapter Chute
58	731-1313C	Chute Tilt Cable Guide
59	941-0475	Plastic Bushing
60	684-04350	Joint Block Assembly
61	784-5594-0637	Cable Bracket
62	784-5647-0637	Chute Crank Bracket
63	712-3004A	Flange Lock Nut, 5/16-18
64	731-04870	Spacer 1.25 x .75 x 1.00

Ref No.	Part Number	Description
1	720-04039	Knob
2	784-5604A-0637	Chute Tilt Handle
3	731-1313C	Chute Tilt Cable Guide
4	712-04063	Nylon Hex Lock Nut, 5/16-18
5	603-0302-0637	Chute Tilt Bracket Assembly
6	710-0262	Carriage Bolt, 5/16-18 x 1.5
7	936-0451	Saddle Washer, .32 x .93
8	941-0475	Plastic Bushing
9	710-0604A	Self Tapping Screw
10	710-05050	Eye Bolt
11	736-0275	Bell Washer, .265 x .75
12	750-04467	Support Chute Tube
13	914-0101	Cotter Pin, .08 x 1.42
14	684-04350	Joint Block Assembly
15	747-1201A	Chute Crank Rod, .38 x 35
16	746-1108	Chute Cable, 62"
17	746-1109	Chute Cable w/ Clip, 62"
18	915-0138	Rolled Pin, 1/8 x .63
19	720-0201A	Crank Knob
20	926-0100	Push Cap, 3/8 ID
21	747-04400A	Rod, .375 x 13.50
22	711-04741	Belt keeper Pin
23	611-0132A-0637	Rod Assembly
24	783-0880D-0637	RH Support Plate Assembly
25	783-0879D-0637	LH Support Plate Assembly
26	683-04150-0637	Lift Bracket Assembly
27	710-0805	Hex Cap Screw, 5/16-18 x 1.50
28	710-0964A	Hex Cap Screw, 5/8-18 x 1.31
29	710-3008	Hex Cap Screw, 5/16-18 x .75
30	714-04061	Quick Release Pin
31	712-0386A	Slotted Hex Nut, 5/8-18
32	912-3000	Hex Lock Nut, 3/8-16
33	712-3022	Hex Lock Nut, 1/2-13
34	914-0470	Cotter Pin, 1/8 x 1.25
35	714-04043	Cotter Pin, Bow Tie
36	916-0102	Snap Ring
37	784-0402-0637	Skid Plate
38	936-0272	Flat Washer, .51 x 1.0 x .060
39	736-0366	Flat Washer, .64 x 1.12 x .125
40	936-0452	Bell Washer, .396 x 1.14 x .095

Ref No.	Part Number	Description
41	783-1014A-0637	Drive Mounting Bracket
42	911-0242	Spacer
43	741-0192	Flange Bearing w/ Flats
44	756-1181A	Drive Pulley, 7"
45	747-1192	Rod, 1/2 x 11.55
46	783-0876	Link, 5.875
47	783-0877	Link, 15.4
48	783-0878B-0637	Link, 13.25
49	911-0332	Clevis Pin, .50 x .78
50	790-00110-0637	Snow Thrower Lift Bracket
51	01001864	Hex Index Washer Screw #10-24
52	710-3143	Pan Phillips Screw, #10-24 x .75
53	710-3180	Hex Cap Screw, 5/16-18 x 1.75
54	915-0114	Heavy Duty Spirol Pin, 1/4 x 1.5
55	720-0274	Handle Grip
56	725-0157	Cable Tie
57	932-0306A	Compression Spring
58	936-0140	Flat Washer, .385 x .62 x .063
59	936-0400	Flat Washer, .194 x .62 x .063
60	746-1103A	Lift Cable, 42" w/ Trigger Control
61	747-1203	Lift Index Rod
62	750-1221-0637	Lift Handle Tube
63	05931A	Bearing Housing, 1.85 ID
64	703-2736-0637	Belt Cover
65	710-0514	Hex Cap Screw, 3/8-16 x 1.0
66	710-3251	Socket Head Cap Screw
67	712-04065	Flange Lock Nut, 3/8-16
68	914-0122	Square Key, 3/16 x .75
69	914-0126	Hi-pro Key, 3/16 x .75
70	917-1714B	Right Angle Drive
71	918-0691	Coupling
72	941-0309	Flange Ball Bearing, .75 x 1.85
73	747-1257	Belt Keeper Rod
74	912-3010	Flange Nut, 5/16
75	618-0411A	Spindle Assembly
76	683-04605-0637	Pulley Mounting Bracket
77	912-0266	Nut, 3/8-16, Jamlock
78	710-0347	Hex Cap Screw, 3/8-16 x 1.75
79	710-04511	Pin 5/16-18
80	710-1260A	Carriage Bolt, 5/16-18 x .62

Model 190-032

Ref No.	Part Number	Description
81	911-0310	Clevis Pin, .5 x 1.18
82	911-1000	Belt Keeper Pin
83	712-04064	Nylon Hex Lock Nut, 1/4-20
84	912-3009	Hex Lock Nut, 5/16-18
85	914-0145	Click Pin, .092 x 1.64
86	714-0147	Internal Cotter Pin, .125 x 1.75
87	930-3000	Reflector
88	732-04237	Extension Spring .50 x 12.00
89	932-0594A	Extension Spring .91 x 7.33
90	784-5727-0637	Idler Pivot Arm
91	736-3072	Flat Washer, .38 x .93 x .11
92	738-0966A	Shoulder Screw, 3/8-16
93	938-0347	Shoulder Spacer, .625 x .169
94	749-1103-0637	LH Support Tube
95	749-1104-0637	RH Support Tube
96	954-3053	V-Belt
97	954-0498	V-Belt
98	756-0627D	Idler Pulley 3.50 dia.
99	783-1291-0637	Idler Bracket
100	738-0143	Shoulder Bolt
101	710-3005	Hex Cap Screw, 3/8-16 x 1.25
102	732-0978	Extension Spring, .620 x 5.62
103	736-3010	Flat Washer, .407 x .812 x .135
104	712-3010	Hex Nut, 5/16-18
105	715-04095	Spirol Pin, .156 x .875
106	710-3022	Hex Cap Screw, 3/8-16 x 2.75
107	710-3144	Hex Cap Screw, 3/8-16 x 2.00
108	756-0487	Idler pulley, 4" Diameter

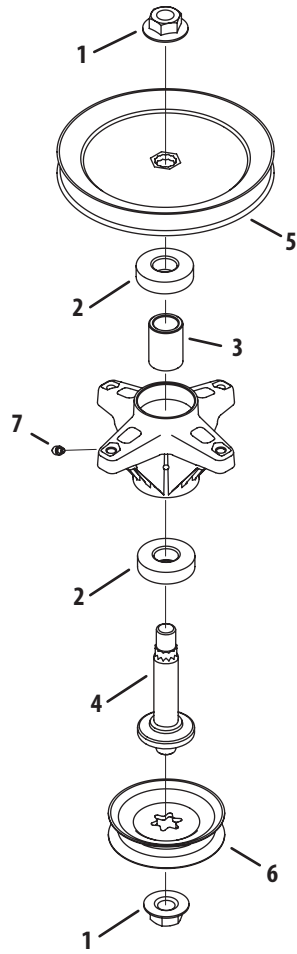

Ref No.	Part Number	Description
1	712-0417A	Flange Nut 5/8-18
2	941-0919	Ball Bearing
3	750-1096	Spacer
4	738-0976	Spindle Shaft
5	756-0999	Deck Pulley 7"
6	756-1173	Pulley 3.75"
7	737-3000	Lube Fitting, 3/16

MANUFACTURER'S LIMITED WARRANTY FOR



The limited warranty set forth below is given by MTD LLC with respect to new merchandise purchased and used in the United States and/or its territories and possessions, and by MTD Products Limited with respect to new merchandise purchased and used in Canada and/or its territories and possessions (either entity respectively, "MTD").

"MTD" warrants this product (excluding its *Normal Wear Parts* and *Attachments* as described below) against defects in material and workmanship for a period of one (1) year commencing on the date of original purchase and will, at its option, repair or replace, free of charge, any part found to be defective in materials or workmanship. This limited warranty shall only apply if this product has been operated and maintained in accordance with the Operator's Manual furnished with the product, and has not been subject to misuse, abuse, commercial use, neglect, accident, improper maintenance, alteration, vandalism, theft, fire, water, or damage because of other peril or natural disaster. Damage resulting from the installation or use of any part, accessory or attachment not approved by MTD for use with the product(s) covered by this manual will void your warranty as to any resulting damage.

Normal Wear Parts are warranted to be free from defects in material and workmanship for a period of thirty (30) days from the date of purchase. Normal wear parts include, but are not limited to items such as: batteries, belts, blades, blade adapters, tines, grass bags, wheels, rider deck wheels, seats, snow thrower skid shoes, friction wheels, shave plates, auger spiral rubber and tires.

Attachments — MTD warrants attachments for this product against defects in material and workmanship for a period of one (1) year, commencing on the date of the attachment's original purchase or lease. Attachments include, but are not limited to items such as: grass collectors and mulch kits.

HOW TO OBTAIN SERVICE: Warranty service is available, WITH PROOF OF PURCHASE, through your local authorized service dealer. To locate the dealer in your area:

In the U.S.A.

Check your Yellow Pages, or contact MTD LLC at P.O. Box 361131, Cleveland, Ohio 44136-0019, or call 1-800-800-7310, 1-330-220-4683 or log on to our Web site at www.mtdproducts.com.

In Canada

Contact MTD Products Limited, Kitchener, ON N2G 4J1, or call 1-800-668-1238 or log on to our Web site at www.mtdcanada.com.

This limited warranty does **not** provide coverage in the following cases:

- a. Log splitter pumps, valves, and cylinders have a separate one-year warranty.

- b. Routine maintenance items such as lubricants, filters, blade sharpening, tune-ups, brake adjustments, clutch adjustments, deck adjustments, and normal deterioration of the exterior finish due to use or exposure.
- c. Service completed by someone other than an authorized service dealer.
- d. MTD does not extend any warranty for products sold or exported outside of the United States and/or Canada, and their respective possessions and territories, except those sold through MTD's authorized channels of export distribution.
- e. Replacement parts that are not genuine MTD parts.
- f. Transportation charges and service calls.
- g. MTD does not warrant this product for commercial use.

No implied warranty, including any implied warranty of merchantability or fitness for a particular purpose, applies after the applicable period of express written warranty above as to the parts as identified. No other express warranty, whether written or oral, except as mentioned above, given by any person or entity, including a dealer or retailer, with respect to any product, shall bind MTD. During the period of the warranty, the exclusive remedy is repair or replacement of the product as set forth above.

The provisions as set forth in this warranty provide the sole and exclusive remedy arising from the sale. MTD shall not be liable for incidental or consequential loss or damage including, without limitation, expenses incurred for substitute or replacement lawn care services or for rental expenses to temporarily replace a warranted product.

Some states do not allow the exclusion or limitation of incidental or consequential damages, or limitations on how long an implied warranty lasts, so the above exclusions or limitations may not apply to you.

In no event shall recovery of any kind be greater than the amount of the purchase price of the product sold. **Alteration of safety features of the product shall void this warranty.** You assume the risk and liability for loss, damage, or injury to you and your property and/or to others and their property arising out of the misuse or inability to use the product.

This limited warranty shall not extend to anyone other than the original purchaser or to the person for whom it was purchased as a gift.

HOW STATE LAW RELATES TO THIS WARRANTY: This limited warranty gives you specific legal rights, and you may also have other rights which vary from state to state.

IMPORTANT: Owner may be required to present proof of purchase to obtain warranty coverage.

MTD LLC, P.O. BOX 361131 CLEVELAND, OHIO 44136-0019; Phone: 1-800-800-7310, 1-330-220-4683
MTD Canada Limited - KITCHENER, ON N2G 4J1; Phone 1-800-668-1238