

Performance Plus 2.0 Series

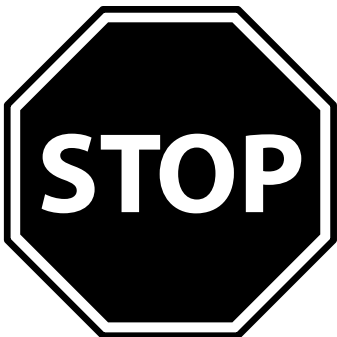

Warning: Excessive weight hazard!

Use two or more people to move, assemble, or install cabinets and locker to avoid back injury. Do not leave children unattended near cabinets. High risk of tipping if cabinets are installed incorrectly: securely attach cabinets to the wall to avoid serious injury. For assistance, call 1.877.306.8930; for U.K 0800.031.4069; e-mail at info@newageproducts.com.



ATTENTION: Is your cabinet damaged? Need help or spare parts? For fastest service, contact NewAge Products at 1-877-306-8930; or support@newageproducts.com. Do not return to the retailer.

INDEX

Product Overview:

- [Unpacking - 3](#)
- [Tools Needed - 3](#)
- [Included Quantities - 4](#)
- [Individual Parts - 4](#)
- [Weight Capacity - 5](#)
- [Worktop Options - 5](#)

[Installation Options - 6](#)

Installation Overview:

- [Sets with Casters - 7](#)
- [Wall Mount Installation - 8](#)
- [Slatwall Installation - 9](#)
- [Floor Mount - 10](#)
- [Corner Set Installation - 11](#)

Hanging Cabinets:

- [On Studded Wall - 12 - 15](#)
- [Hanging Corner Cabinet - 15](#)
- [Installing Spacer Kit - 16](#)
- [On Slatwall - 17](#)

Securing Cabinets:

- [To Wall - 18](#)
- [To Other Cabinets - 19](#)
- [Fastening Cabinets with Casters - 20](#)

Installing Worktop:

- [Normal installation on cabinets - 21](#)
- [Using Support Brackets - 22](#)
- [Installing Side Support Tray - 23](#)
- [Installing Worktop Support Leg - 24/25](#)
- [Corner Worktop - 26](#)

General Assembly:

- [Feet & Levelling cabinets - 27](#)
- [Casters - 28](#)
- [Drawers - 29](#)
- [Handles - 30](#)
- [Stacking - 31](#)
- [Closet Rod - 32](#)
- [Shelves - 33](#)
- [Base Cabinet Pullout Shelf - 34](#)
- [Utility hole - 35](#)
- [Magnetic Racing Stripe - 36](#)
- [Hinge Adjustment - 37](#)

[Warranty - 38](#)

Unpacking

- Begin by placing the package on a covered flat surface.
- Remove all cardboard, foam packaging material and clear plastic bags.
- Dispose / recycle all packaging materials.
- Verify all the contents in the box and gather the required tools. See “Tools Needed”, and “Included Quantities” list.

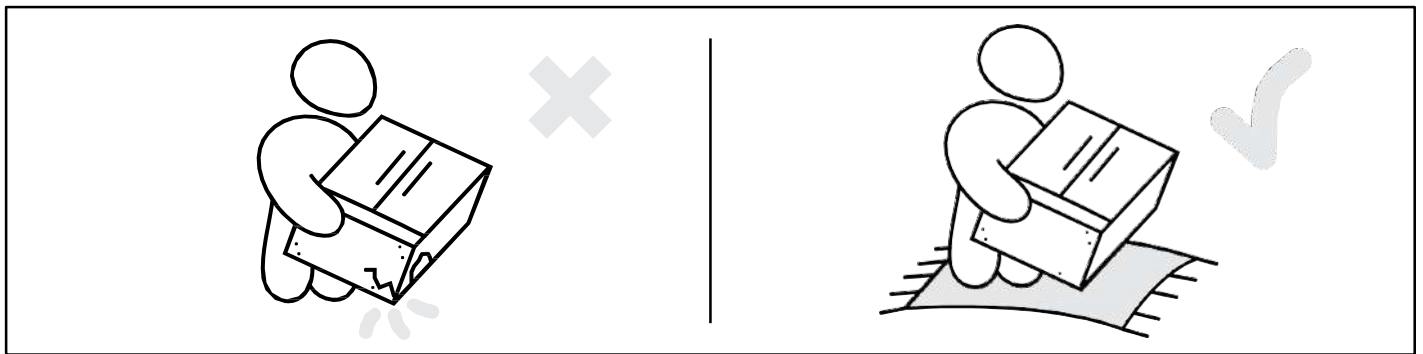
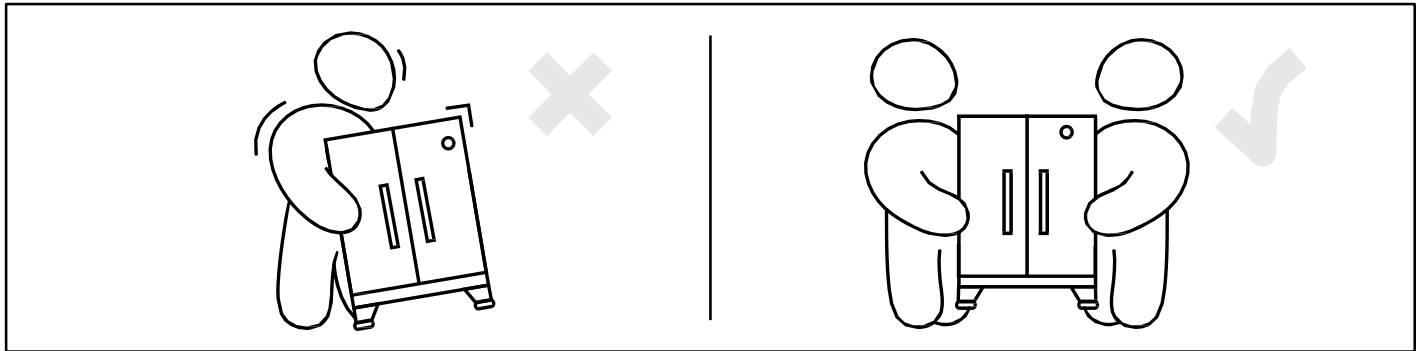

Tools Needed



1 x Adjustable wrench

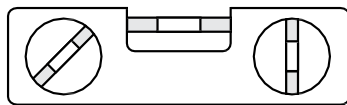

1 x 12" Magnetic Level



1 x Stud Finder



1 x Tape Measure



1 x 7/16" Socket driver wrench



1 x 7/16" socket

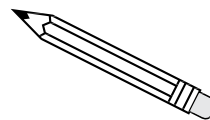

1 x Pencil

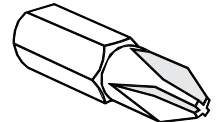

1 x #2 Phillips Bit

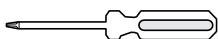

1 x #2 Phillips head screwdriver



1 x
6 mm or 3/16"
drill bit



1 x Cordless Power Drill

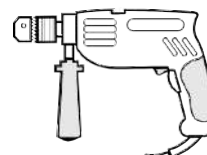

1 x Hammer Drill



1 x Masonry Bit
[optional for masonry]

Included Quantities

	Base Cabinet	Tool Drawer	Locker	Wall	Corner Wall	Mobile Locker	Spacer Kit
Hardware Pack	1	1	1	1	1	1	0
Cabinet Leg	4	4	4	0	0	0	0
Leveling Foot	4	4	4	0	0	0	0
Casters	2	2	0	0	0	2	0
Casters with Brakes	2	2	0	0	0	2	0
Adjustable Steel Shelf	0	0	4	1	0	3	0
Drawer Dividers	0	3	0	0	0	0	4
Easy Wall Hanging Bracket	2	2	2	2	2	2	0
Handles	2	5	2	0	0	2	0
Closet Rod and Clothes Hooks(set)	0	0	1	0	0	1	0
Locker Support Bracket	0	0	1	0	0	0	0
Joining Bracket	1	1	0	0	2	0	0
Rubber Tray Liner	1	1	0	0	0	0	0
EVA Foam Drawers Liners	1	5	0	0	0	0	0
Utility Hole Grommet	1	0	1	0	0	1	0
NewAge Logo	1	1	1	1	1	1	0
2.5in Spacer Wall Cabinet	0	0	0	0	0	0	2
2.5in Worktop Tray	0	0	0	0	0	0	2

Individual Parts

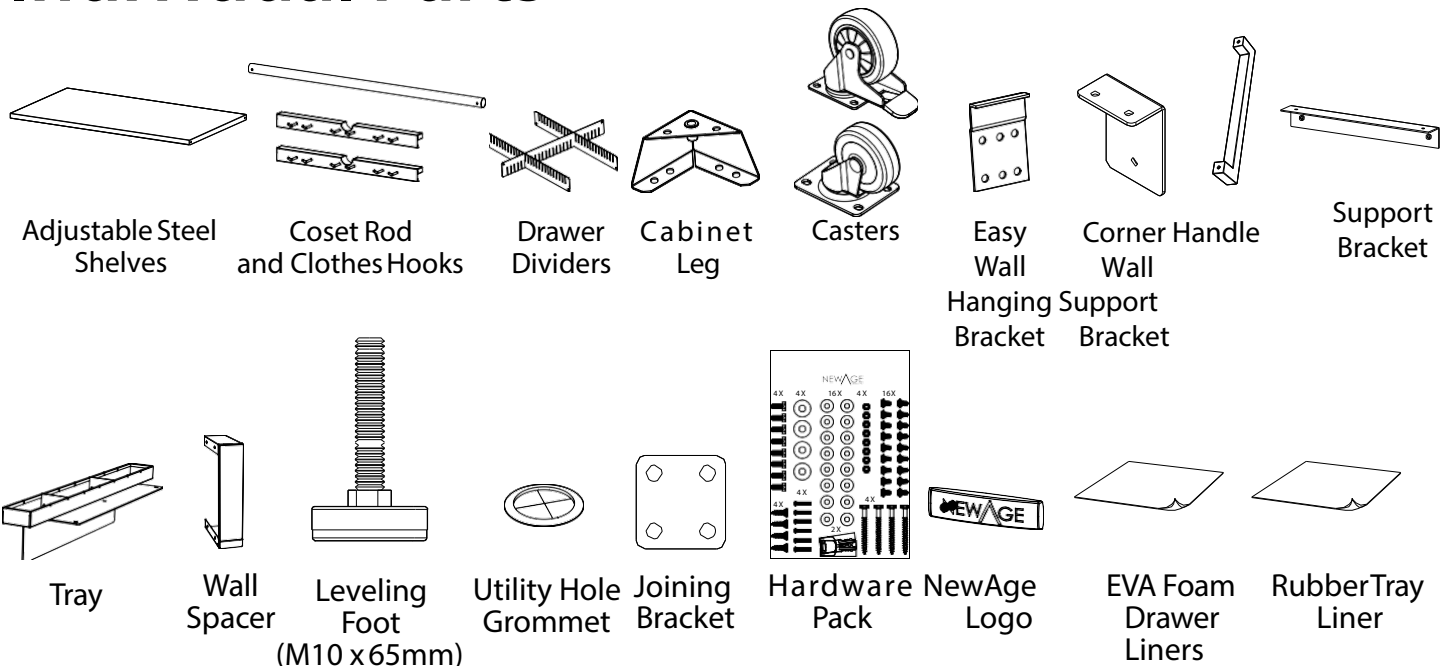

Weight Capacity



250 lbs per foot.
1000 lbs. per set of 4



150 lbs. per Caster
500 lbs. per set of 4

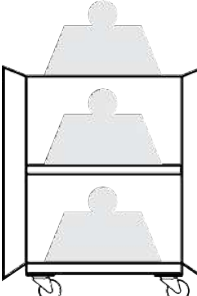

Base Cabinet
Max 1000lbs.



100lbs.
100lbs.
Wall Cabinets
Max 200 lbs.

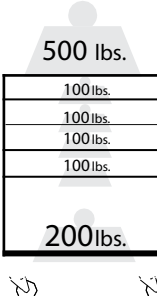

500 lbs.
100lbs.
100lbs.
100lbs.
100lbs.
200lbs.
Tool Cabinet
Max 1000 lbs.

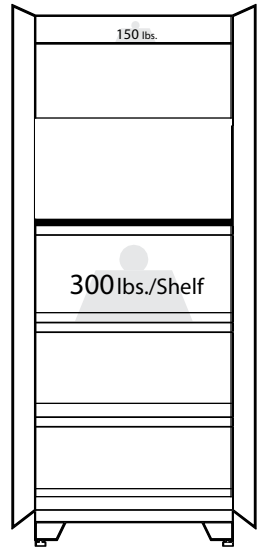

150 lbs.
300lbs./Shelf
Locker 300lbs. / Shelf
Max 1000lbs. / Locker

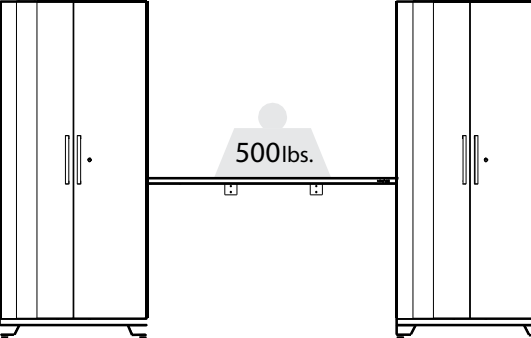

500lbs.
Floating Worktop
Max 500lbs.

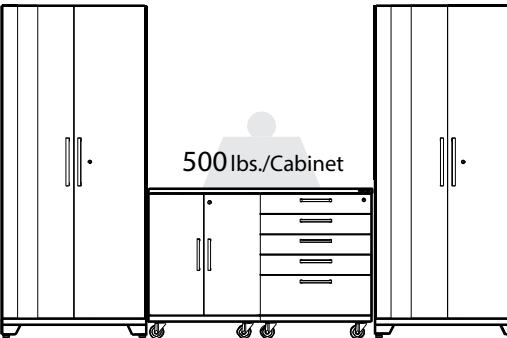

500lbs./Cabinet
Worktop on Base Cabinets
Max 500lbs./Cabinet

Worktop Options



24"Corner Worktop

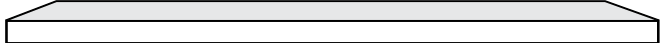

56"Worktop. Fits over 2 Cabinets

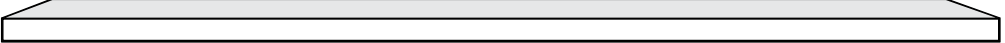

84"Worktop. Fits over 3 Cabinets

Installation options for Cabinets

i **Important information:** Please read before beginning installation.

- Layouts shown are only examples. All cabinets are modular and can be configured in a variety of different layouts.
- Plan layout and measure space before installing.
- Locate wall studs prior to installation.
- Consider the location of electrical outlets when planning layout.
- Measure height of cabinets for clearance.
- Base cabinets can be mounted flush front or flush back with Locker cabinets.

Option 2. - see [page 8.](#)

Wall mount cabinets off the floor.

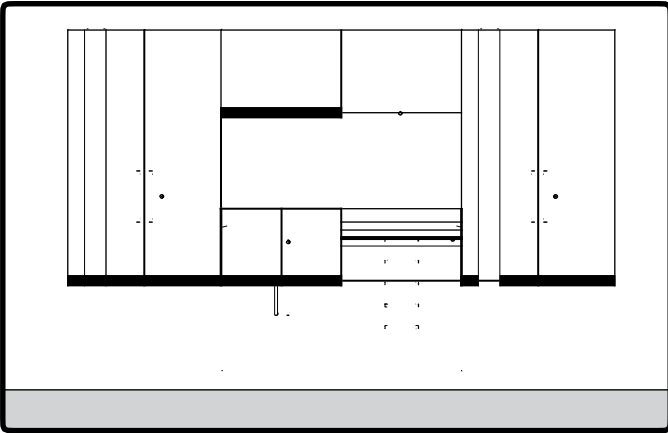

Option 4. - see [page 10](#)

Floor mount with adjustable levelling legs.

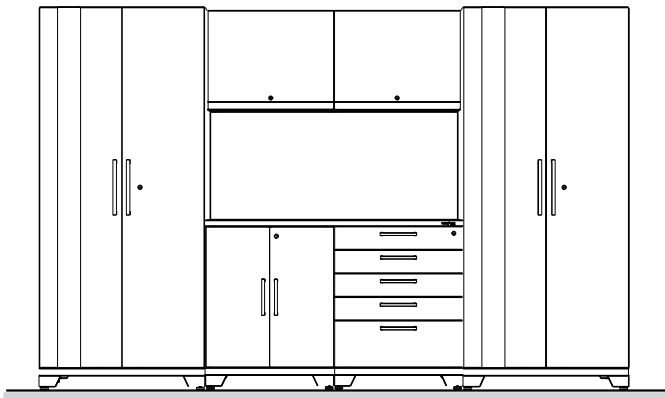

Option 1. - see [page 7.](#)

Sets with casters and adjustable leveling legs. **Note:** Casters cannot be installed on Locker cabinets.



Option 3. - see [page 9.](#)

Wall mount on slatwall using slatwall brackets (sold separately).

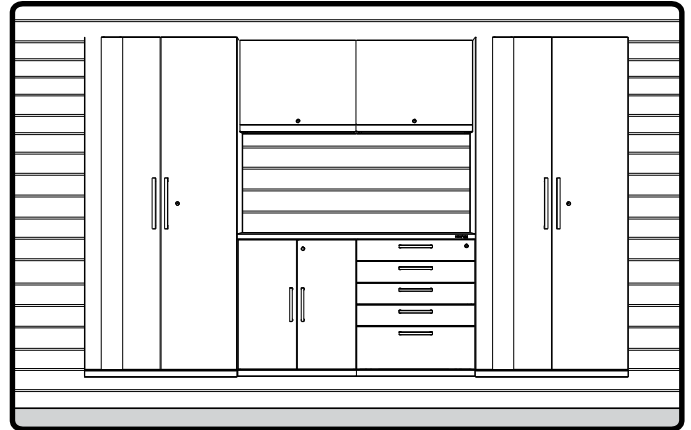

Option 5. - see [page 11](#)

Corner cabinet installation. **Note:** Corner cabinets can be installed using all installation options.

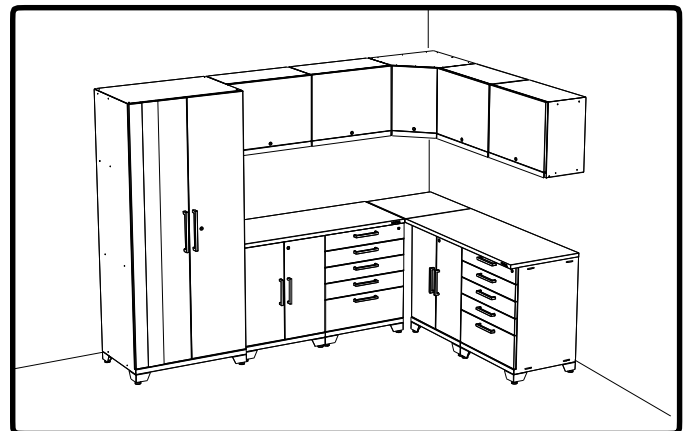

Option 1

Caster Set Installation Overview

i Plan layout before installing cabinets.

- It is recommended to begin installation with Locker cabinet.
- Install cabinets one at a time.
- Locker and wall cabinets must be fully secured to wall using (4) wall screws per cabinet.

2 Begin by securing Locker cabinet to wall in determined position. See [Page 18](#) for full instructions.

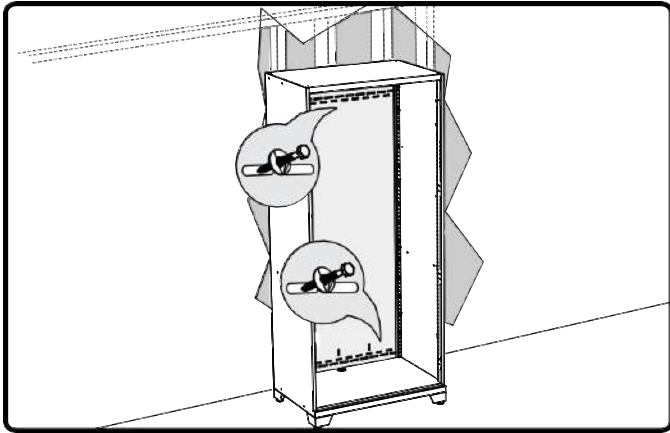

4 Install Worktop Wall Support Brackets, Leg Supports and attach worktop.

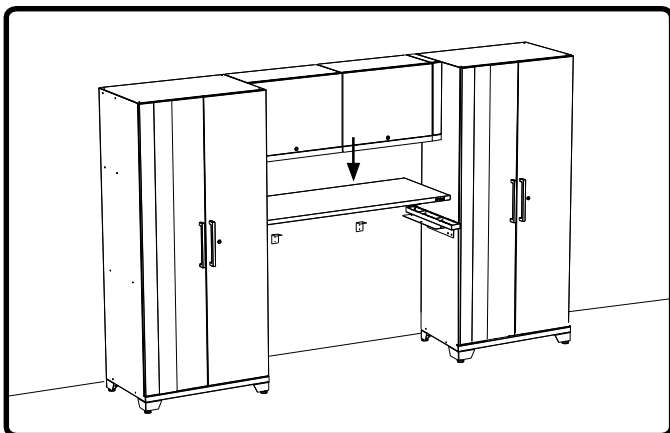

1 Attach feet to locker cabinets. Attach casters to base cabinets. See full installation on [pages 27 & 28](#).

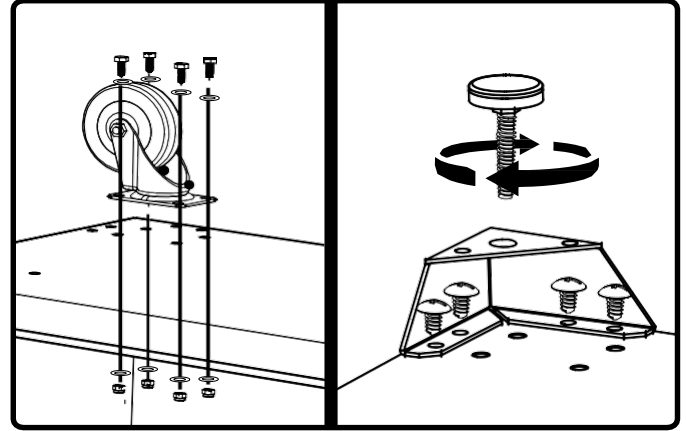

3 Secure remaining wall, locker and spacer kit starting with spacer kit. See [pages 12-16, 19](#) and [23](#).

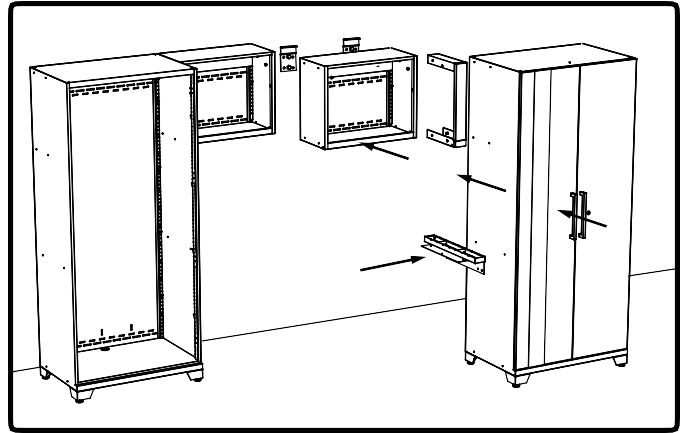

5 Position cabinets in place below worktop.

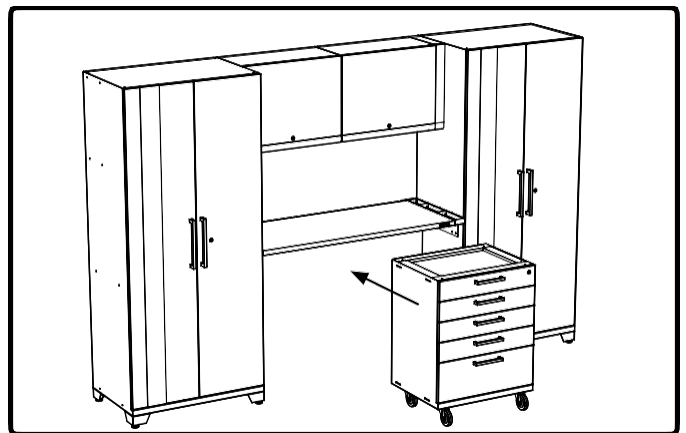

Option 2

Wall Mount Installation Overview

i Plan layout before installing cabinets.

- Determine height cabinets will be installed off the ground.
- It is recommended to begin installation with Locker cabinet.
- Install cabinets one at a time.
- Cabinets must be fully secured to wall using (4) wall screws per cabinet.

1 Begin by attaching Locker cabinet to wall. See [page 12-16](#) for full instructions on hanging cabinets.

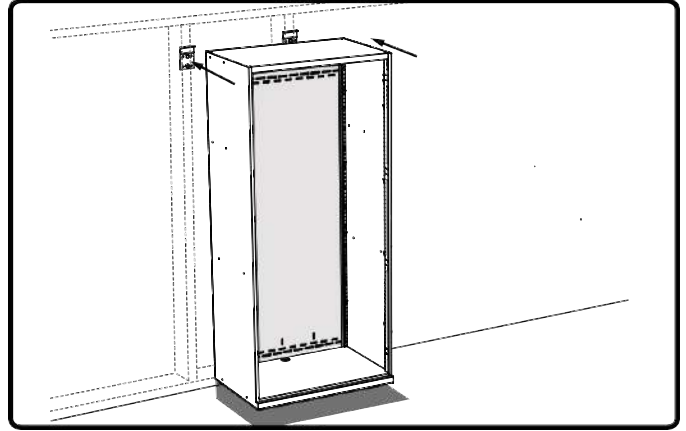

2 Position and secure remaining base cabinets, and wall cabinets to wall. See [page 12-16](#).

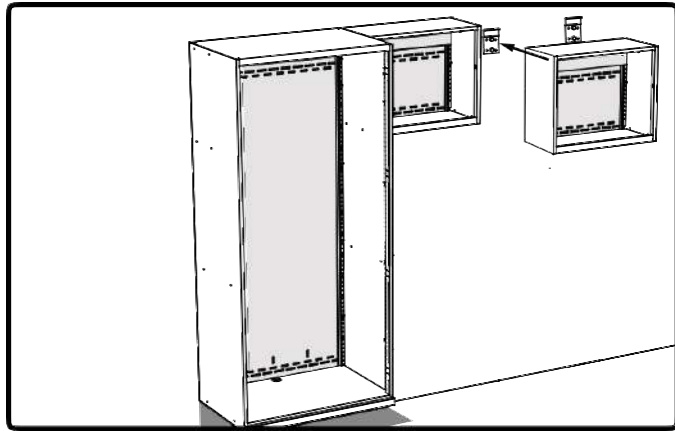

3 Secure cabinets to wall. See [page 15](#).

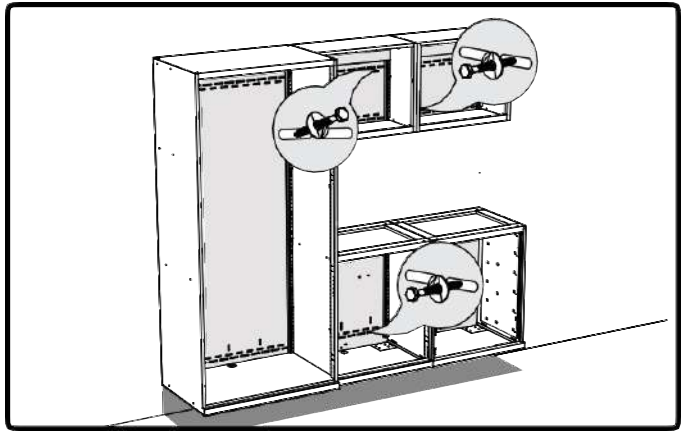

4 Secure cabinets together. See [page 19](#).

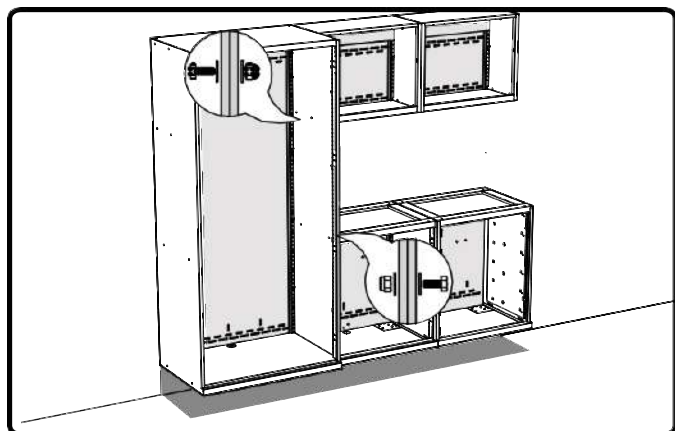

5 Attach worktop. See [page 21](#) for full instructions.

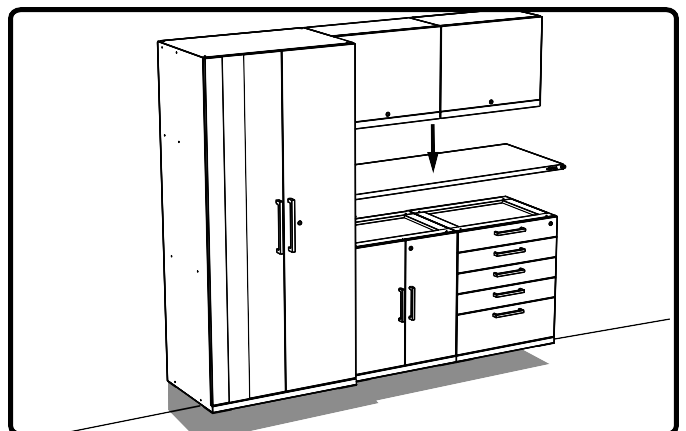

Option 3

Slatwall Installation Overview

i Plan layout before installing cabinets.

- Determine height cabinets will be installed off the ground.
- Slatwall bracket sold separately
- Slatwall brackets for use with standard 3" slatwall.
- Check slatwall manufacturer for rated load capacity.
- Do not overload.

2 Position and secure remaining base cabinets, and wall cabinets.

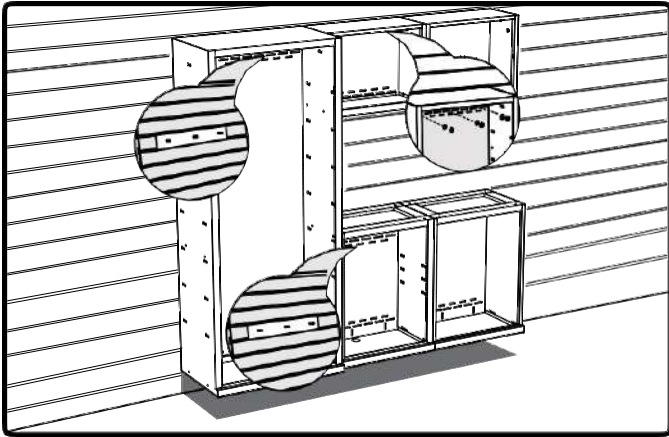

4 Attach worktop. See [page 21](#) for full instructions.

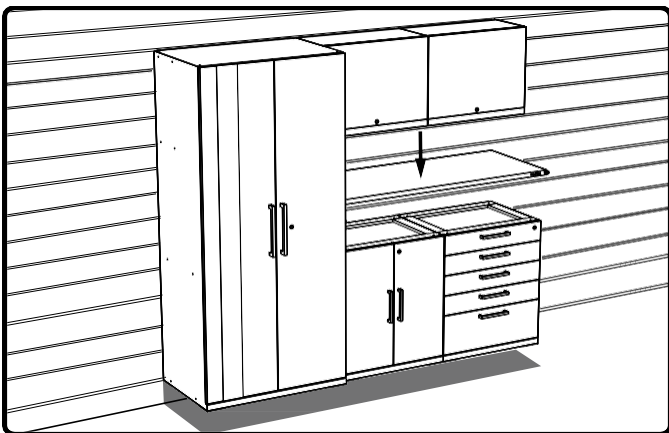

1 Begin by attaching Locker cabinet to Slatwall using Slatwall bracket. See [page 17](#) for slatwall hanging instructions.

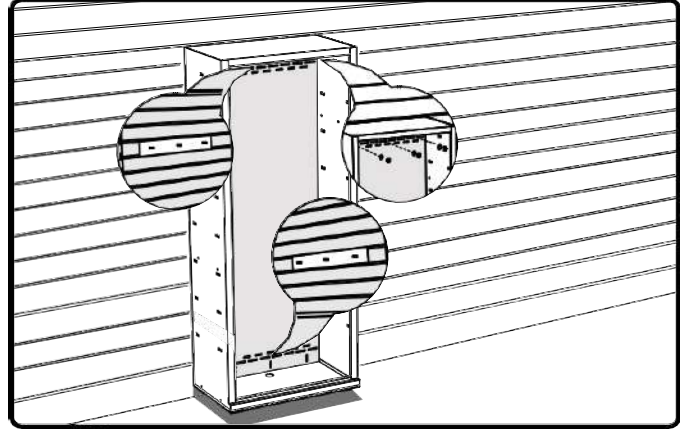

3 Attach cabinets together. See [page 19](#).

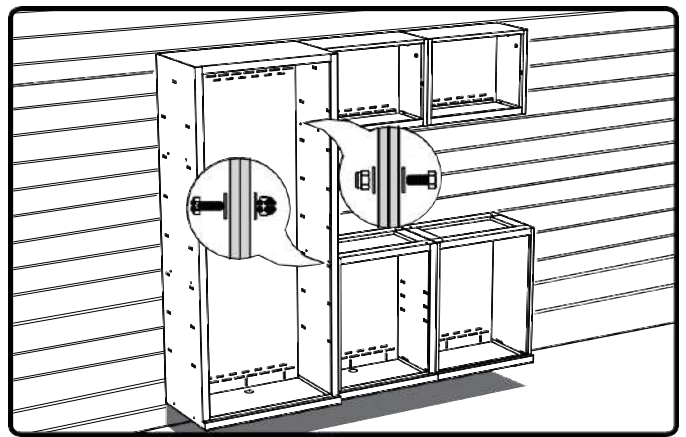

Slatwall brackets sold separately. See below for quantities needed.

- Locker, Tool and Base Cabinets - per cabinet (2) x 24" Slatwall Brackets. Part # 50979
- Wall Cabinets - per cabinet (1) x 24" Slatwall Brackets. Part # 50979
- Corner Wall Cabinets - per cabinet (2) x 12" Slatwall Cabinets. Part # 50980

Option 4

Floor Installation Overview

i Plan layout before installing cabinets.

- It is recommended to begin installation with Locker cabinet.
- Cabinets must be fully secured to wall using (4) wall screws per cabinet.
- Casters can not be installed on 36" locker cabinets.

2 Begin by securing Locker cabinet to wall in determined position. See [Page 18](#) for full instructions.

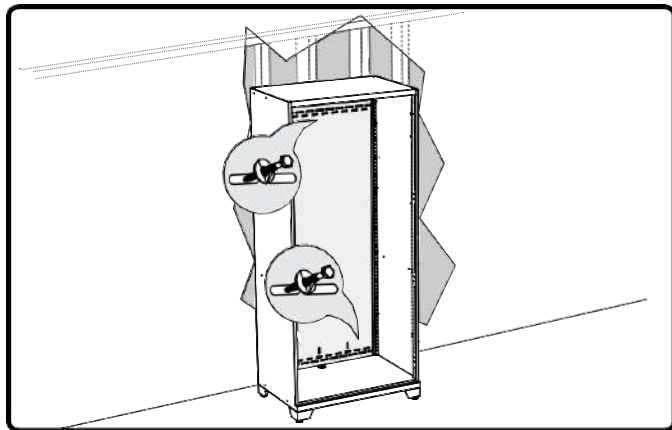

4 Attach cabinets together. See [page 19](#) for detailed fastening instructions.

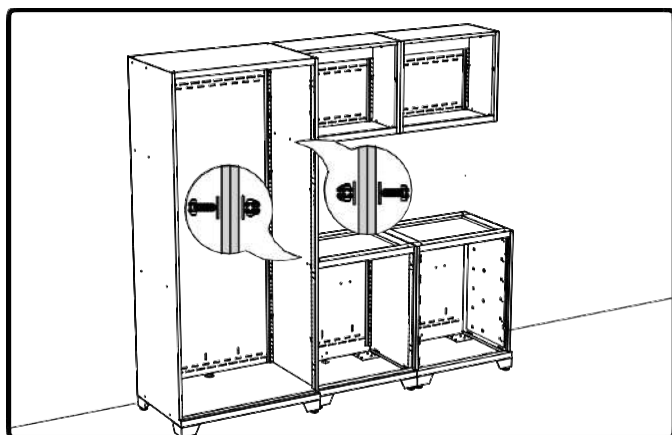

1 Attach feet to cabinets. See full feet installation on [page 27](#).

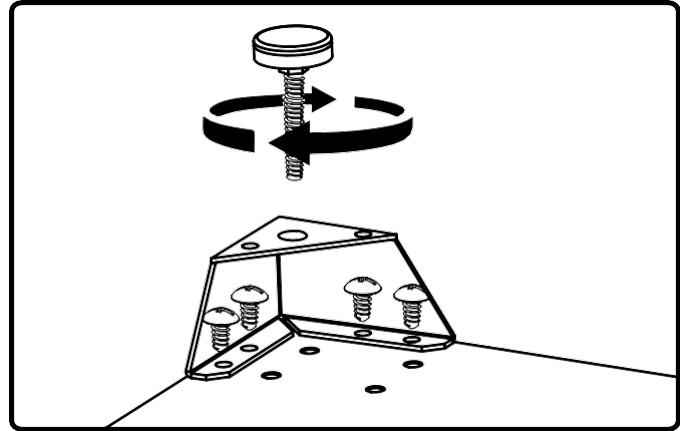

3 Position and secure remaining cabinets to wall. Install cabinets one at a time. See [page 18](#) for full instructions.

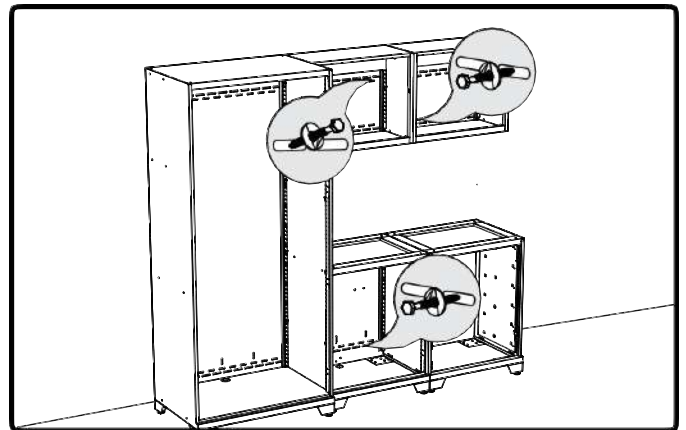

5 Attach worktop. See [page 21](#) for full instructions.

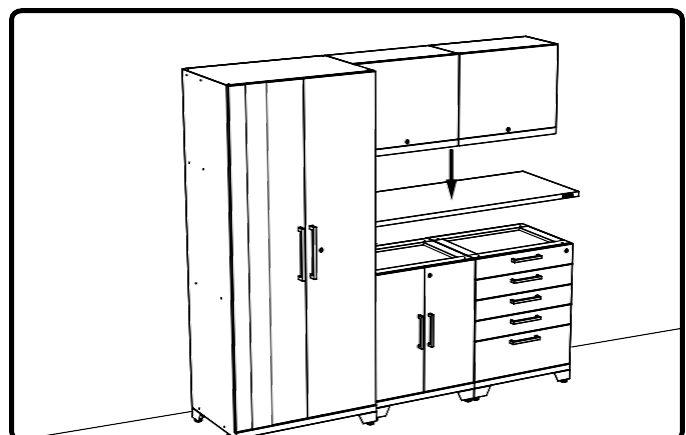

Option 5

Corner Set Installation Overview

- 1** Attach feet to cabinets. See full feet installation on [page 25](#).

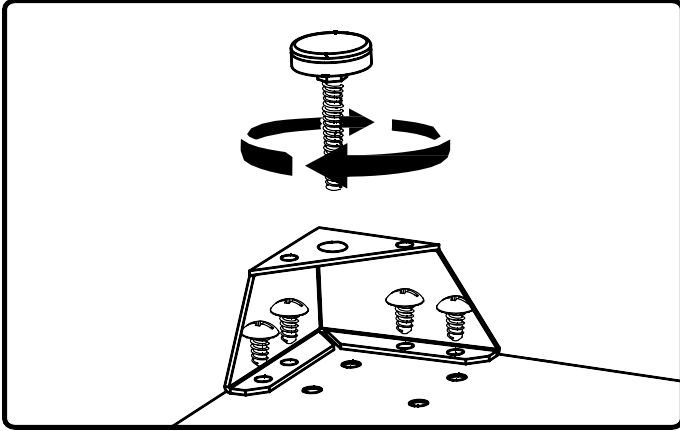

- 2** Hang wall cabinets starting with corner wall cabinet. See full instructions on [pages 12-16](#).

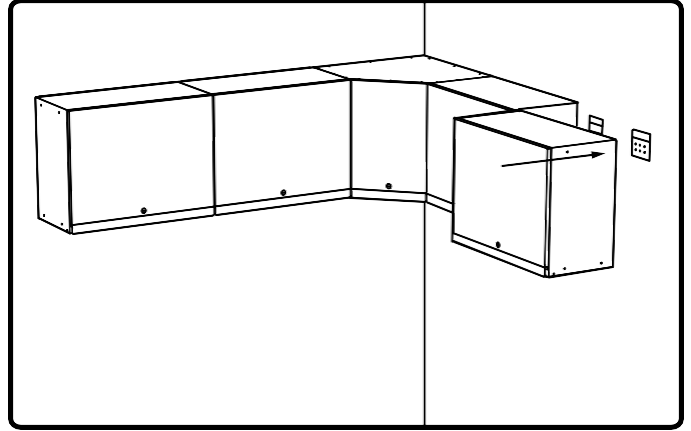

- 3** Install corner worktop support and base cabinets. See [page 26](#).

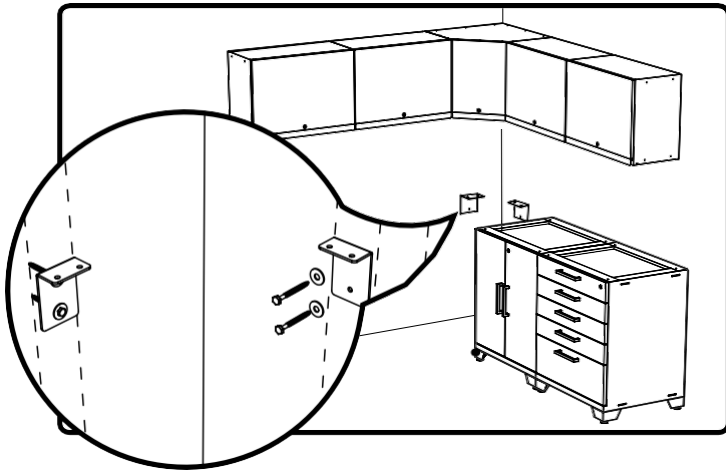

- 4** Install corner worktop. See [page 26](#).

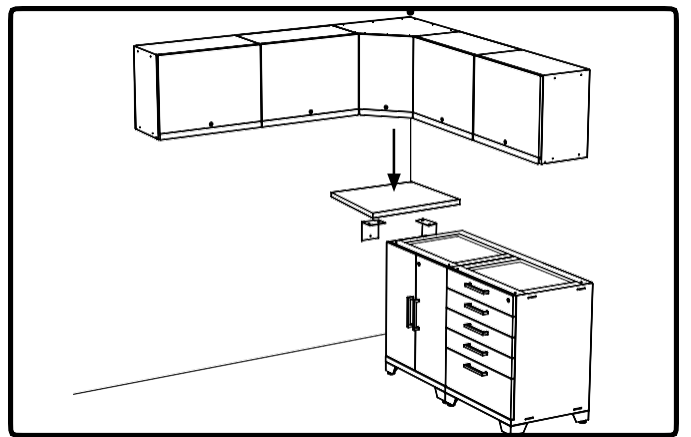

- 5** Position, secure and attach all remaining cabinets and worktops. See [page 18,19](#) and [21](#).

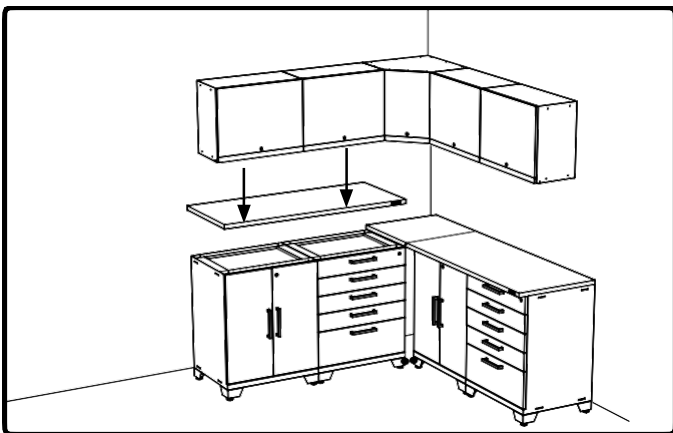

- 6**

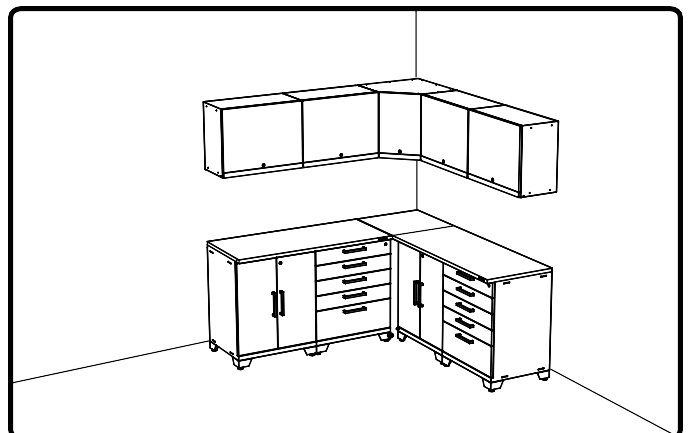

Hanging Cabinets on Studded Wall

i Parts Needed.

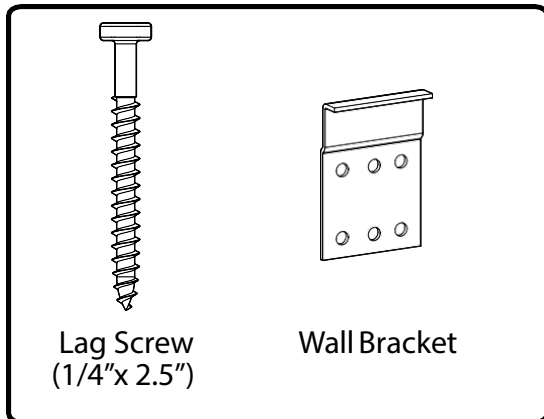

1 Use stud finder to locate the studs and mark the wall with a pencil.

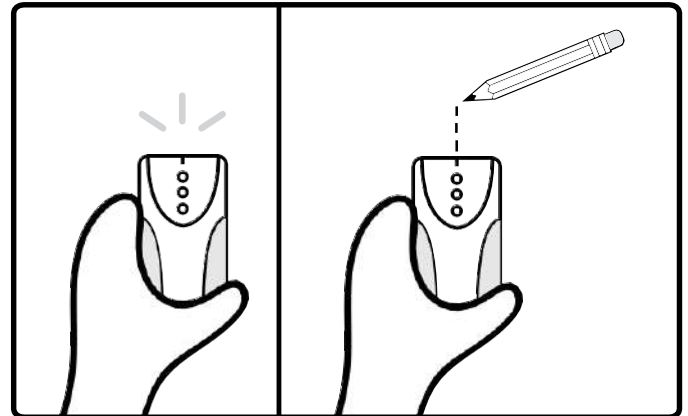

2 Planning the general position of cabinets.

- Step A.** Determine the height off the ground you would like the base and locker cabinets to be and make a horizontal mark at this position.
- Step B.** Next mark the width of each cabinet in the intended position and ensure the wall studs fall at least 1.25" in from the edge of the cabinets. This will ensure there is no interference with the edges of the cabinet and the wall bracket when hanging the cabinet on the wall.
- Step C.** For corner installation begin by hanging corner cabinet first and continue out from corner.

Note: Ensure there are two studs for the locker to be mounted on as it is easiest to start the installation with the locker first. Due to the spacing of the wall studs it is possible that some base or wall cabinets will only have one stud they will attach to; This is acceptable as long as the cabinet is bolted to another securely mounted cabinet.

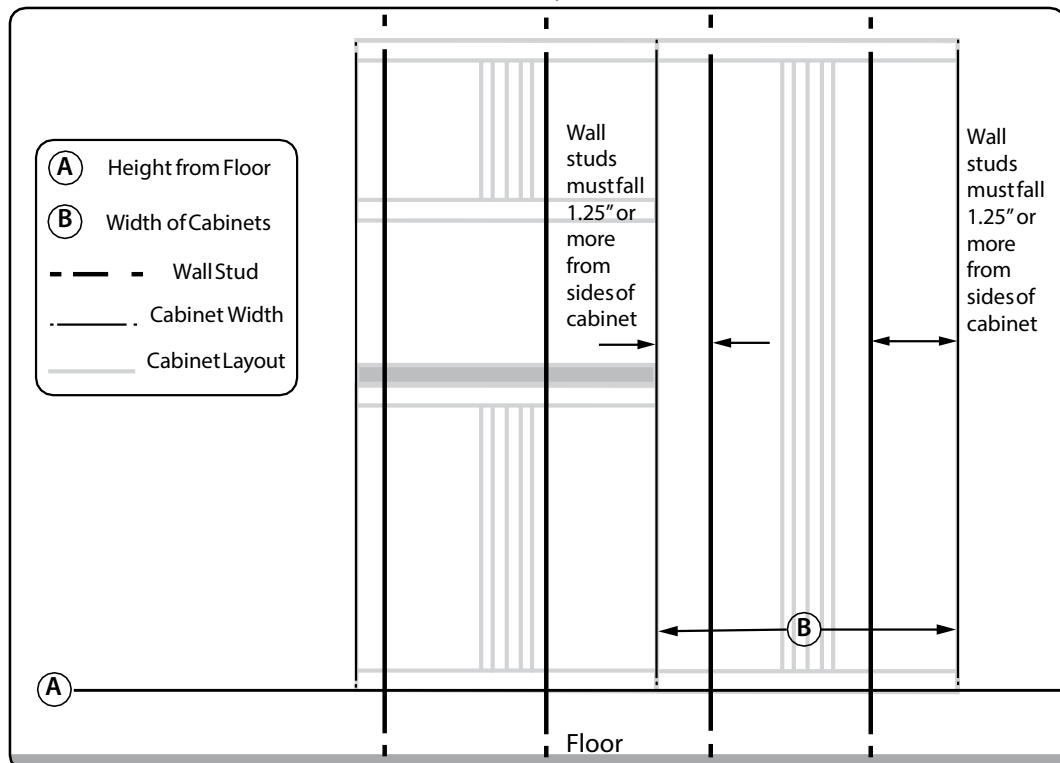

Hanging Cabinets on Studded Wall (cont.)

3 Planning the general position of cabinets. (cont.)

Step C. Measuring up from the line marked in Step A, make a horizontal mark at the following heights where they intersect the wall stud marks to determine where the top of the cabinet will be (and where the hanging bracket will be installed).

- 1. Locker:** Measure 80" vertically from base line and mark at stud locations.
- 2. Base:** Measure 32.25" vertically from base line and mark at stud locations.
- 3. Wall cabinets:** Measure 80" vertically from base line and mark at stud locations (if installing flush with top of locker).

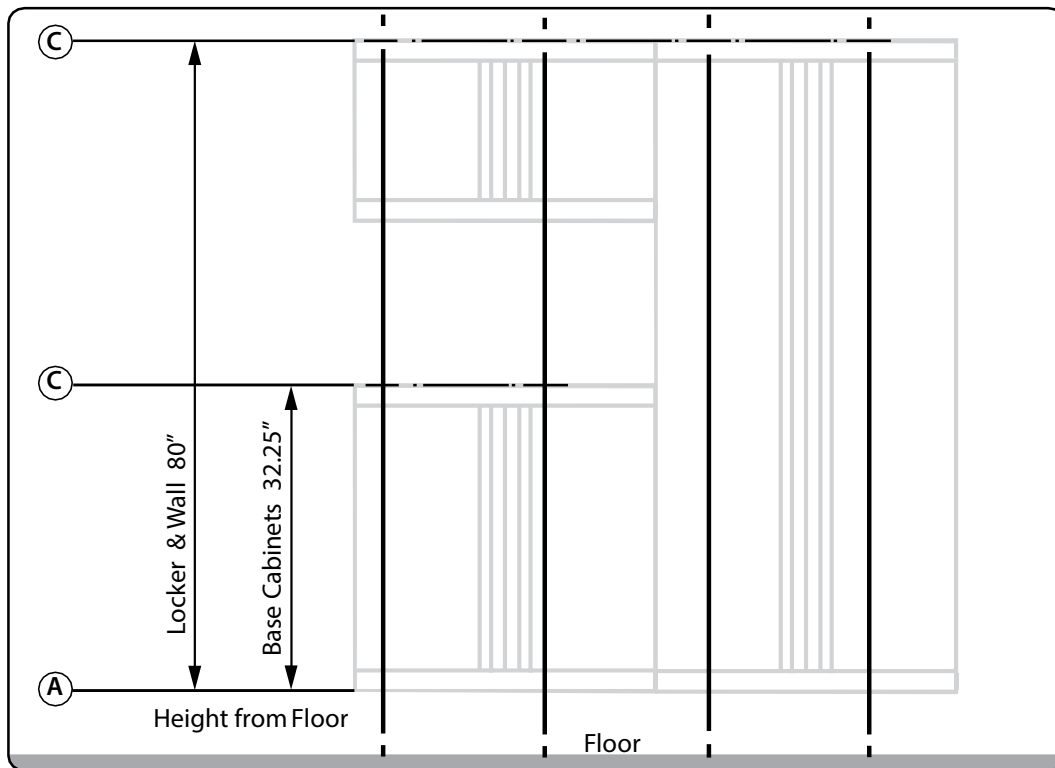

Step D. Ensure the cabinets will be at a suitable working height and that your wall cabinets are not out of reach.

Note: The working surface of the base cabinets will be 1.25" higher than the cabinet with the top installed.

Hanging Cabinets on Studded Wall (cont.)

4 Hanging cabinets on wall.

Align the top of the wall hanging brackets with the lines marked for the position of the top of the cabinets (Step C) and attach the brackets securely into the studs using the supplied lag bolts.

Note: It is possible to offset the bracket to one side or the other if the bracket is positioned close to the edge of the intended cabinet position by using the secondary hole positions on the bracket.

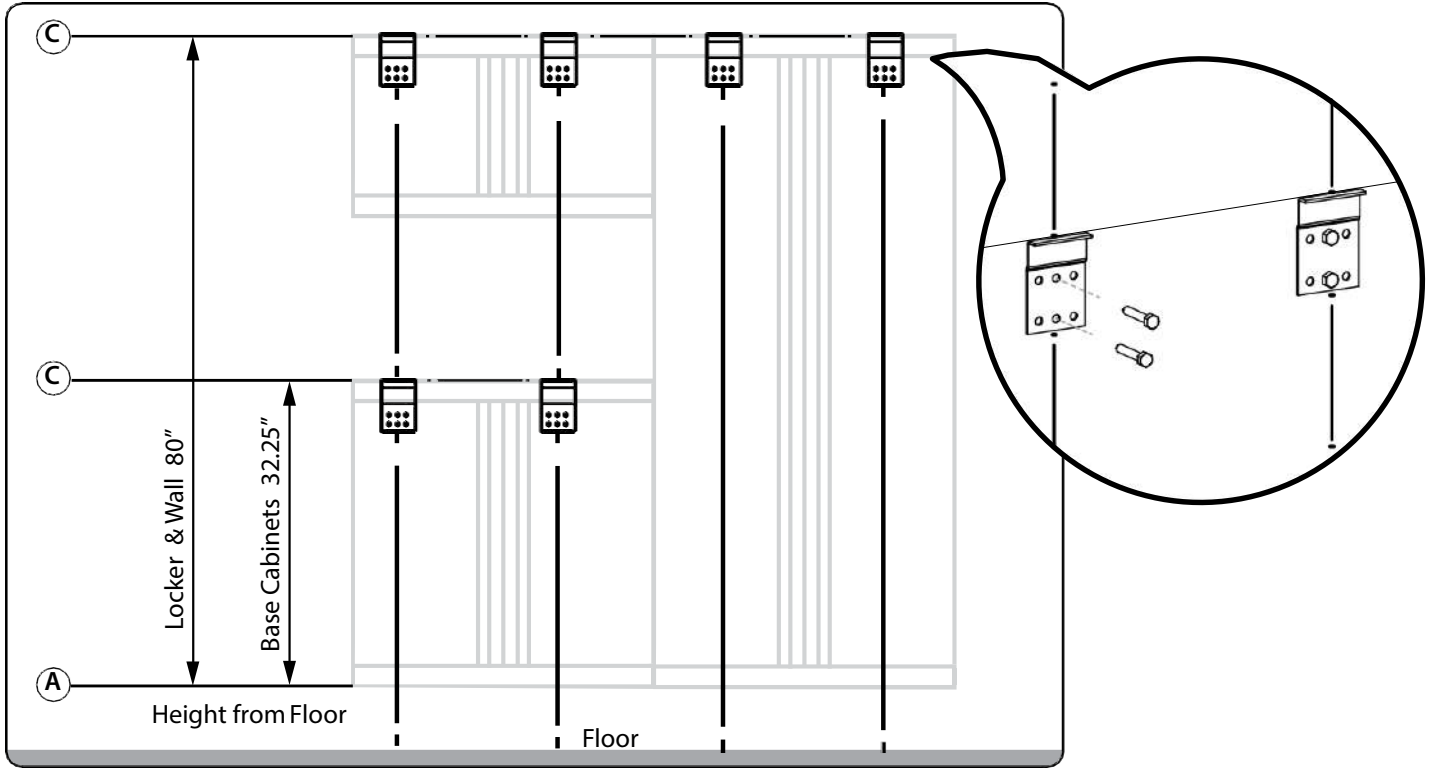

Hanging Corner Cabinets on Studded Wall

5 Begin with the corner wall cabinet and use (2) X Wall Support Brackets to hang cabinet following Steps 1-6 from pages 12-15.

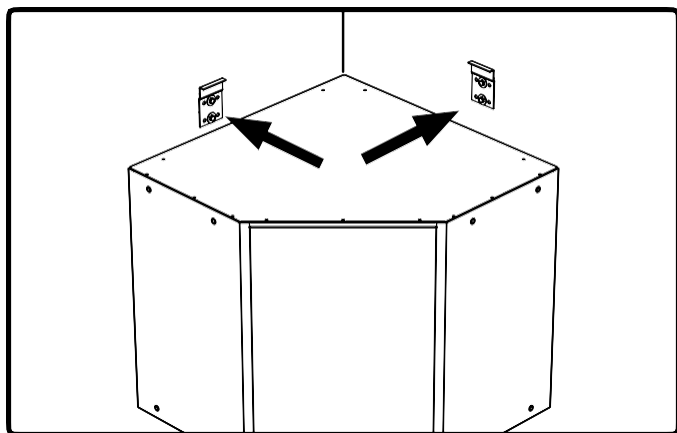

6 Hang and secure remaining wall cabinets following "Hanging Cabinets on Studded Wall" and "Fastening Cabinets Together" see pages 12-15 and page 19.

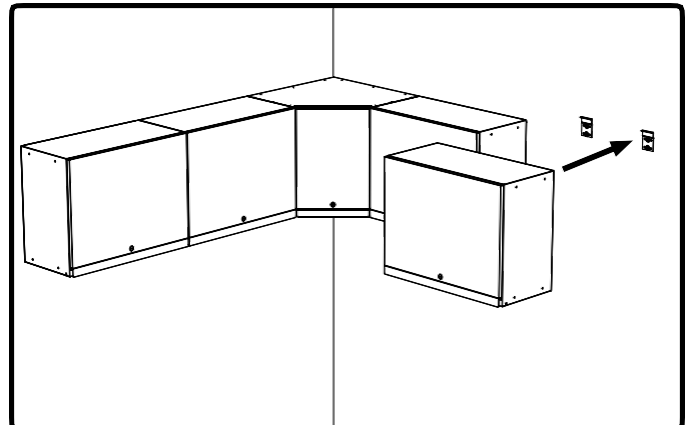

Hanging Cabinets on Studded Wall (cont.)

- 7** Lift cabinet into place over the brackets and flush with the wall, and lower into place.

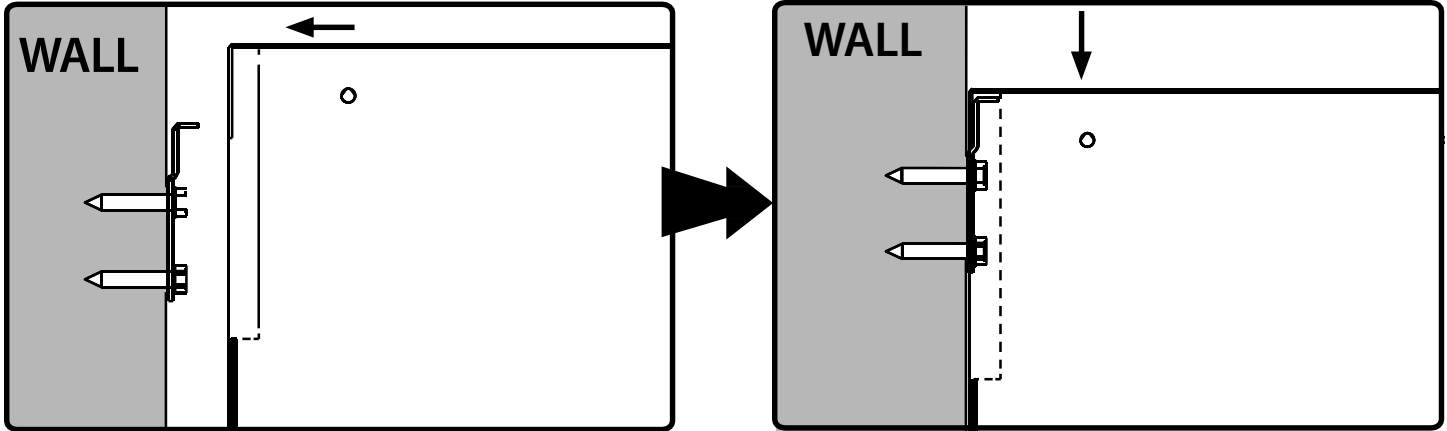

- 8** Fasten cabinets to wall. See page 18.

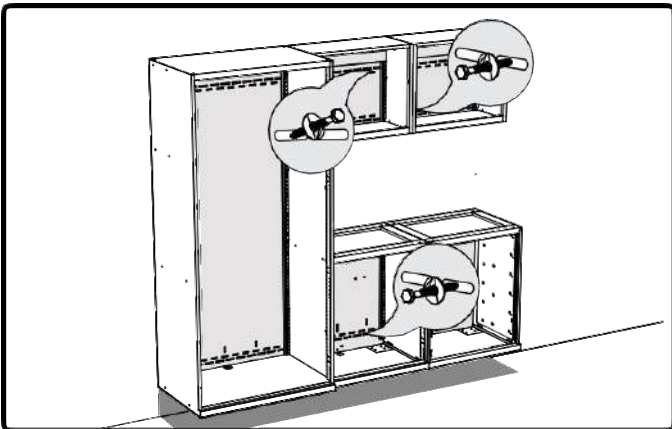

i Warning

- Do not load cabinets when hanging from **Easy Wall Hanging Cabinets**.
- All cabinets must be secured to the wall using lag screws.

i Masonry.

- Follow steps 1 to 4.
- Drill 4 pilot holes through the perforated strip with hammer drill & masonry bit.
- Use 4 x (2 1/4" x 1/4") Tapcon Concrete Anchor (Not included) into wall.
- **OR** 4 x (#10 x 2") Screw with 3/16" masonry plug into wall. (Not included)

Installing Wall Spacer Kit

1 Parts Needed.

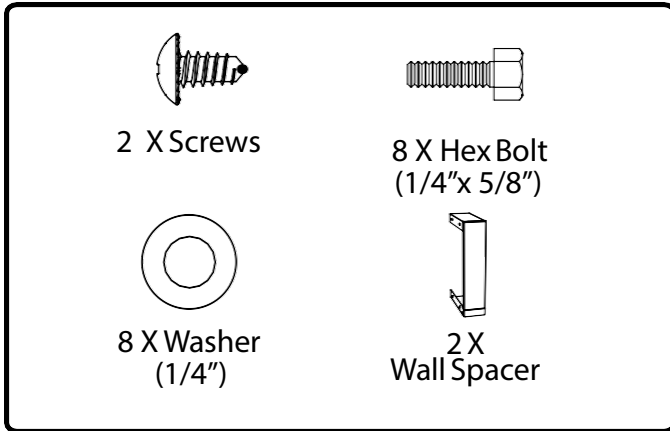

2 Attach spacer cabinet to side of locker using 1/4" hex bolts and washers

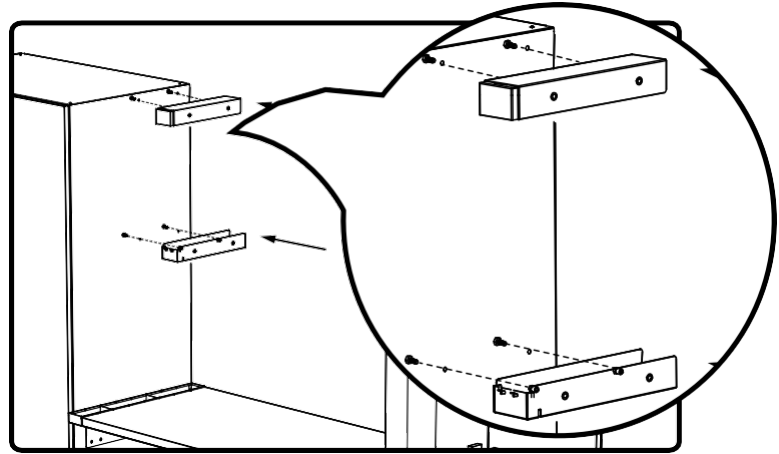

3 Insert tab of spacer cabinet into slot of upper frame. Slide door down into place and secure using screws.

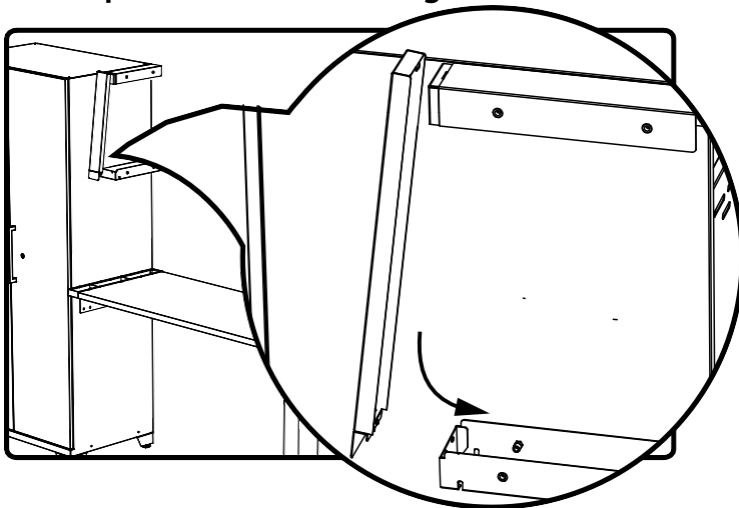

4 Install screw to secure front face.

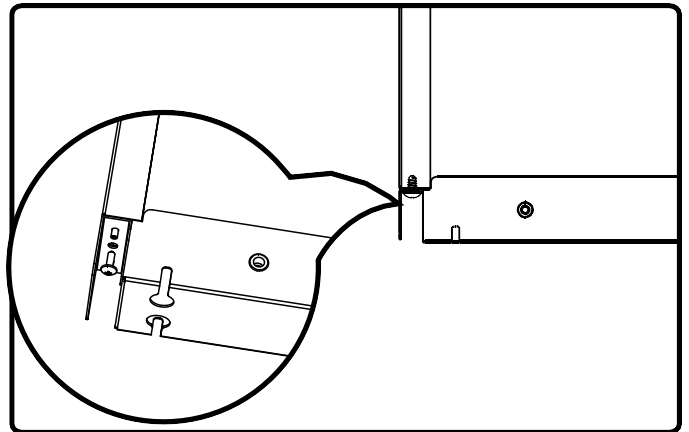

5 Install 2nd wall spacer by repeating Steps 2 - 4.

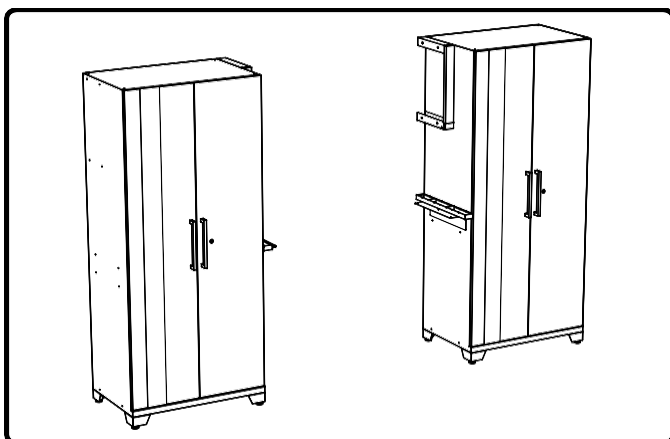

6 Attach remaining wall cabinets. See [pages 12-15](#).

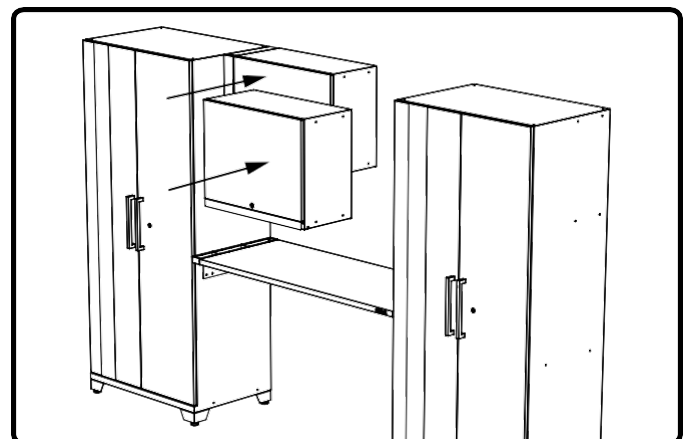

Hanging Cabinets on Slatwall

Note: Slatwall Brackets for use with standard 3" slatwall **Sold Separately**. Check with your slatwall supplier to determine the rated capacity of your slatwall. **DO NOT OVERLOAD.** **NewAge Slatwall Brackets are only compatible with standard 3" on center Slatwall.**

i Parts Needed.

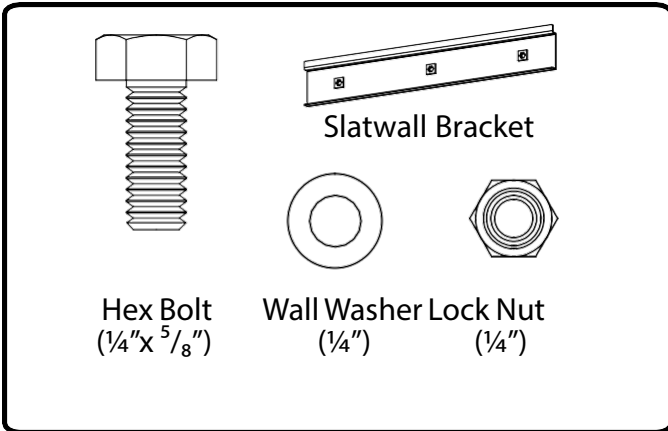

1 Insert bolts through slatwall bracket.

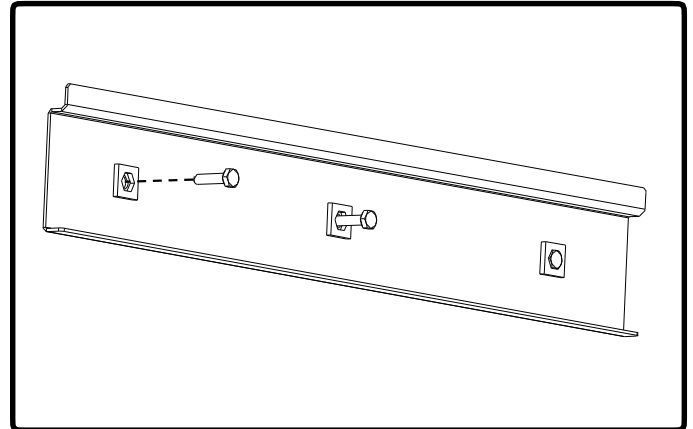

2 Attach bracket to slatwall at desired height.

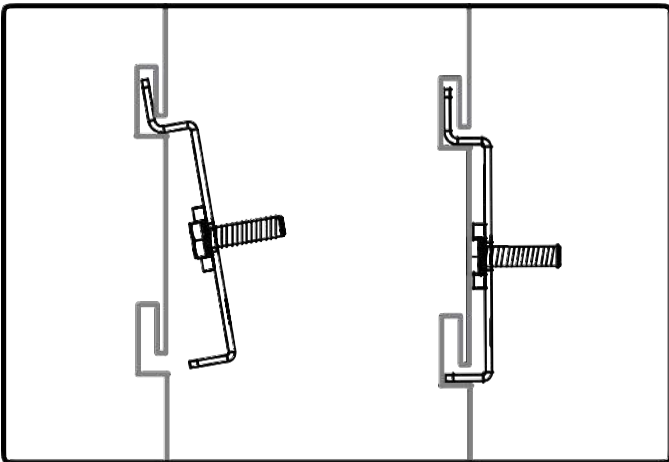

3 Align bolt with slots on back of cabinet and hang cabinet.

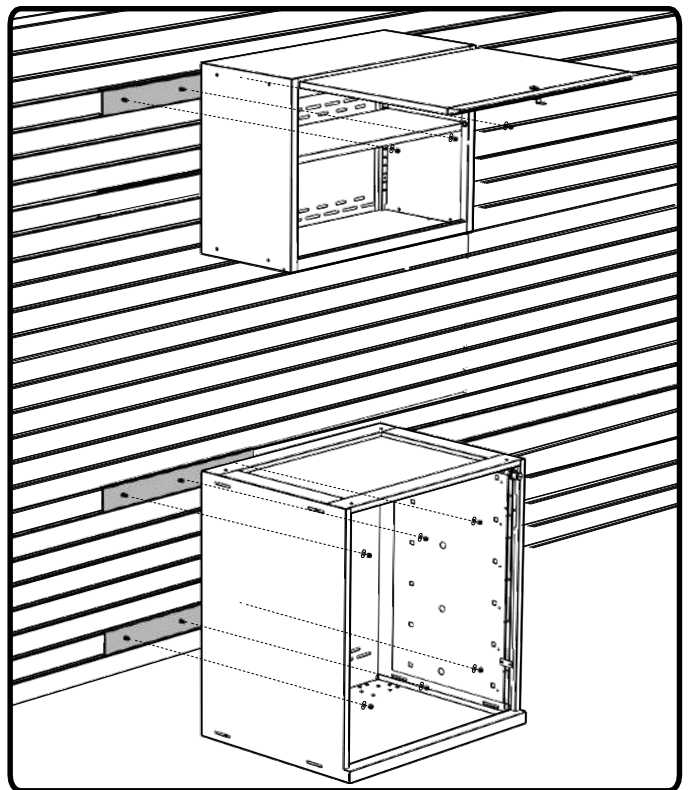

Slatwall brackets sold separately. See below for quantities needed.

- Locker, Tool and Base Cabinets - per cabinet (2) x 24" Slatwall Brackets. Part # 50979
- Wall Cabinets - per cabinet (1) x 24" Slatwall Brackets. Part # 50979
- Corner Wall Cabinets - per cabinet (2) x 12" Slatwall Cabinets. Part # 50980

Note: For Locker cabinet attach second bracket 66" below first bracket. For Base cabinet attach second bracket 18" below first bracket.

Fastening Cabinets on Studded Wall

1 Use stud finder to locate the studs and mark the wall with a pencil.

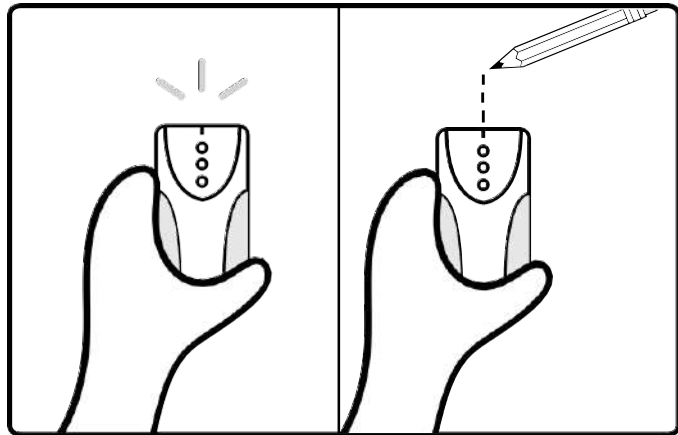

2 Gather parts.

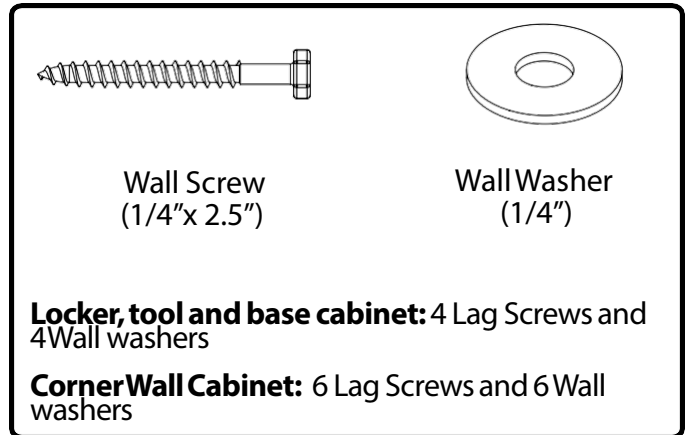

3 Place cabinet tight against the wall.

4 Align cabinet to stud marks.

5 Level cabinet

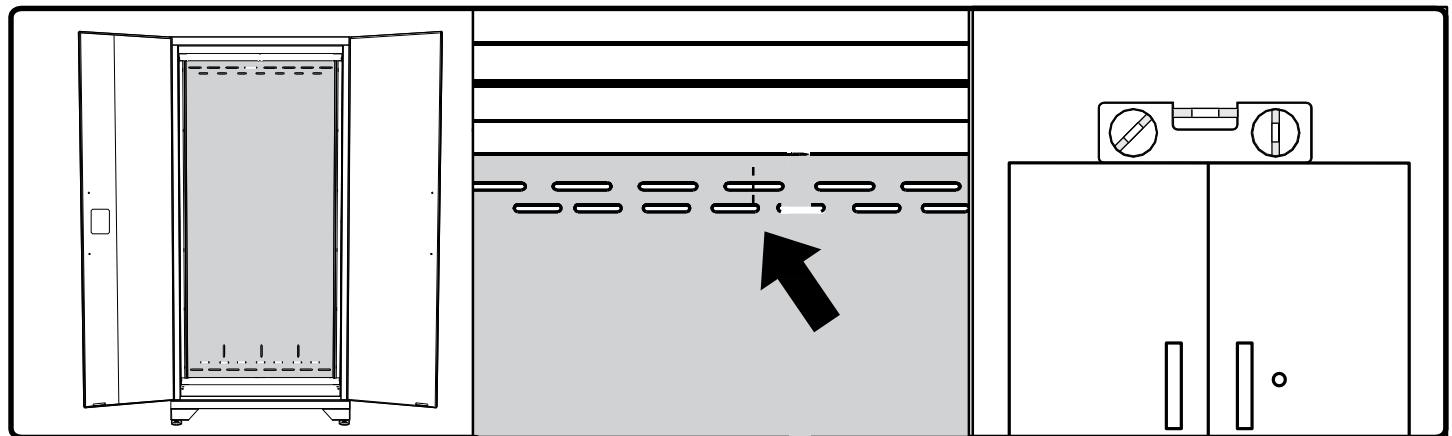

6 Drill 4 wall screws and washers through perforated holes into studs.

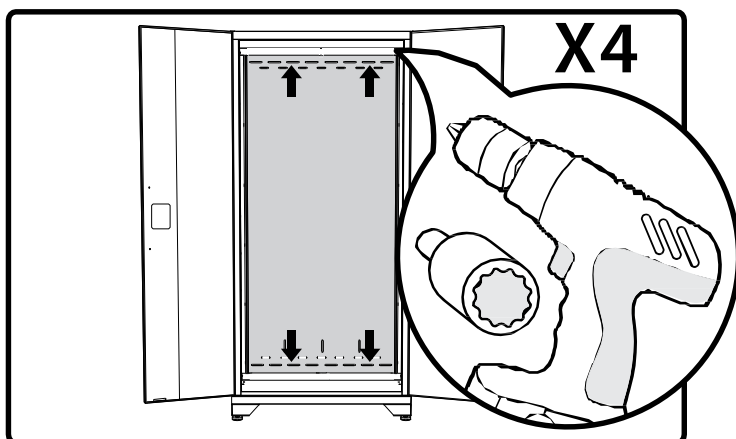

i Masonry.

- Follow steps 1 to 6.
- Drill 4 pilot holes through the perforated strip with hammer drill & masonry bit.
- Use 4 x (2 1/4" x 1/4") Tapcon Concrete Anchor into wall.
- **OR** 4 x (#10 x 2") Screw with 3/16" masonry plug into wall.
- Follow Step 6.

Fastening Cabinets Together

Note:

All drawers must be removed prior to fastening cabinets together. See [Page 29](#) for drawer removal instructions.

1 Parts Needed.

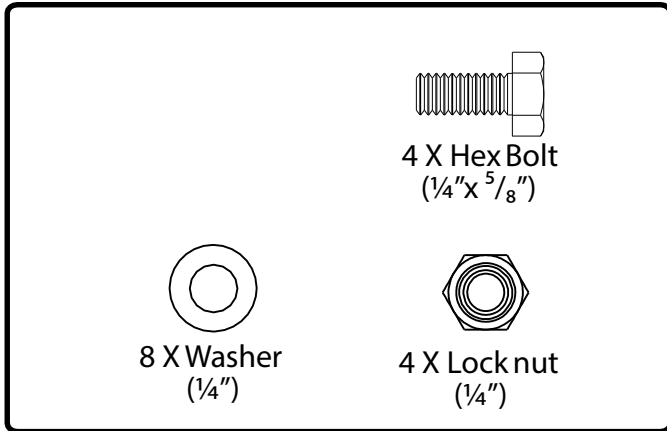

2 Align bolts, tighten lightly.

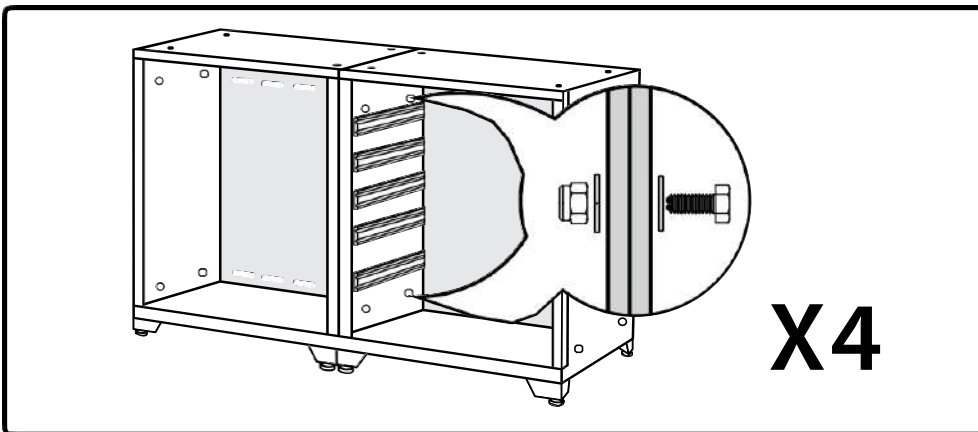

4 Level cabinets and tighten all bolts.

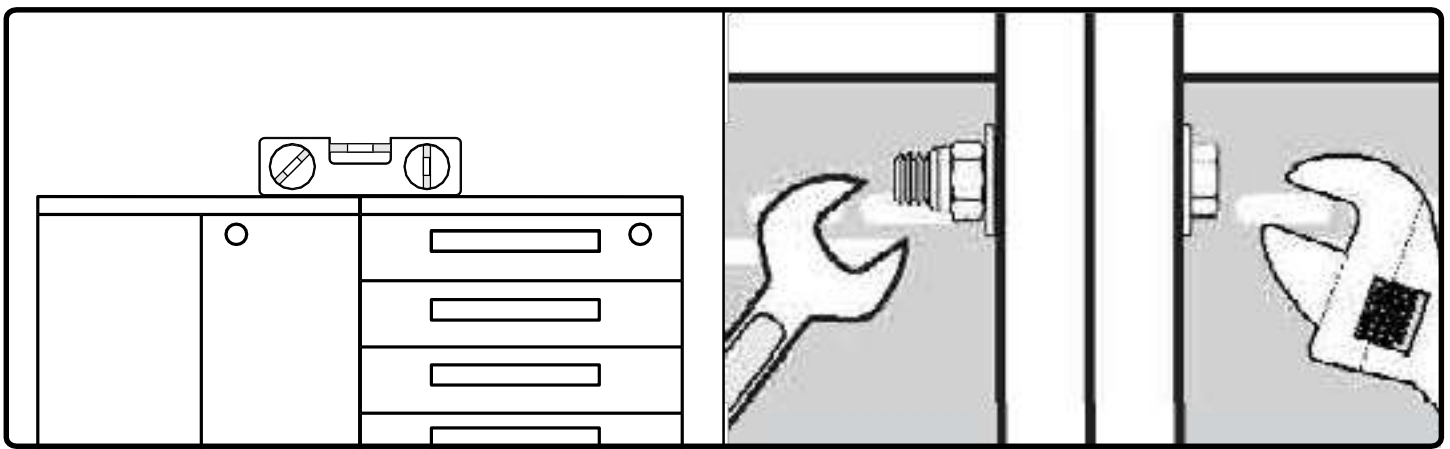

Fastening Cabinets with Casters

i Parts Needed.

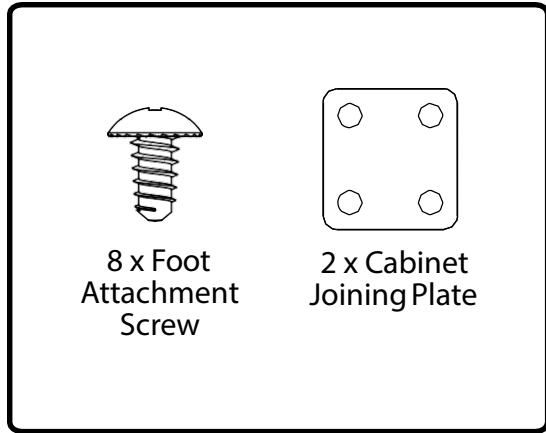

1 Open cabinets, remove any shelves, drawers or loose items.

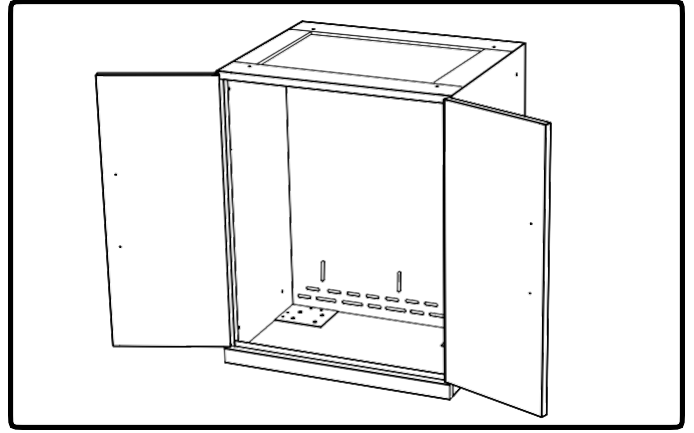

2 Flip cabinets and push sides together, locate holes on edges.

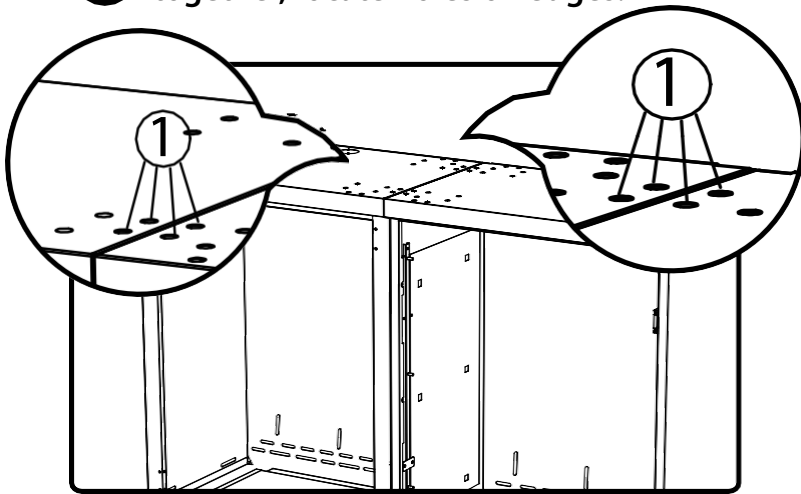

3 Align holes with joining plate and attach using foot attachment screws.

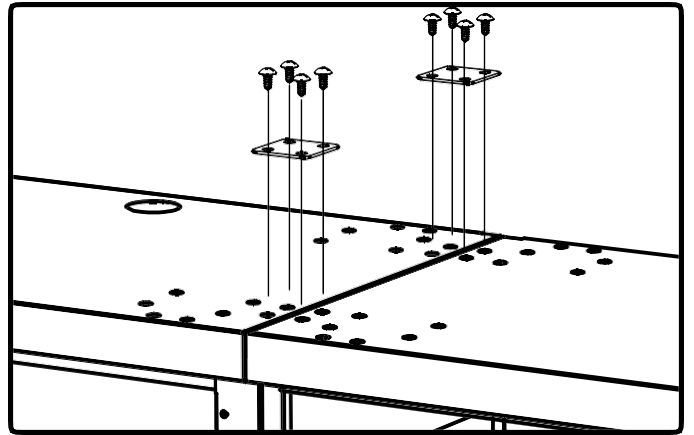

4 Attach casters and fasten cabinets together. See [pages 19 & 28](#).

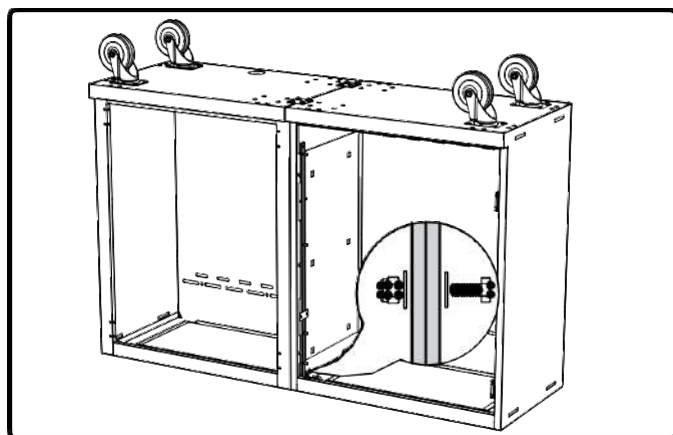

5

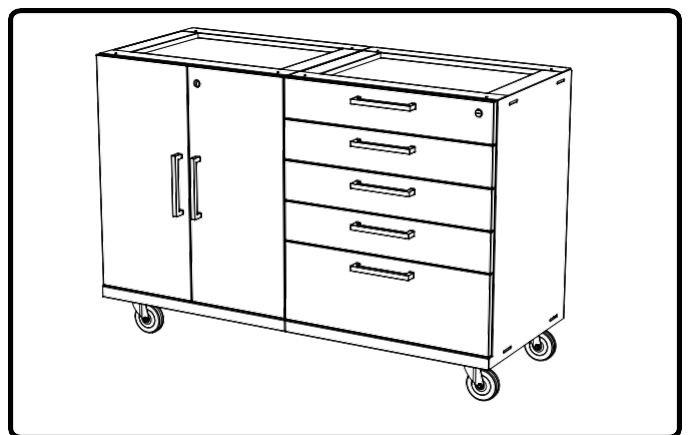

Mounting the Worktop

i Parts Needed.

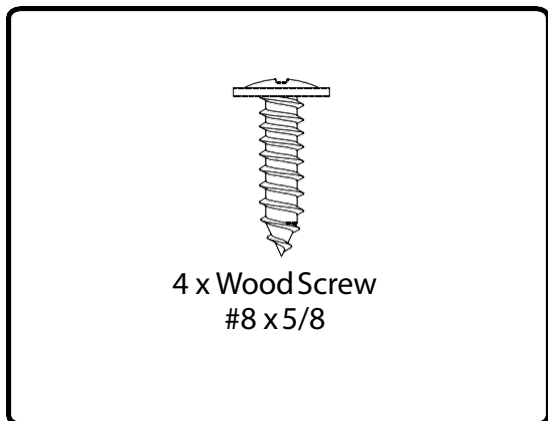

1 Place Worktop on cabinets. Locate the punch holes on the tops of the cabinets.

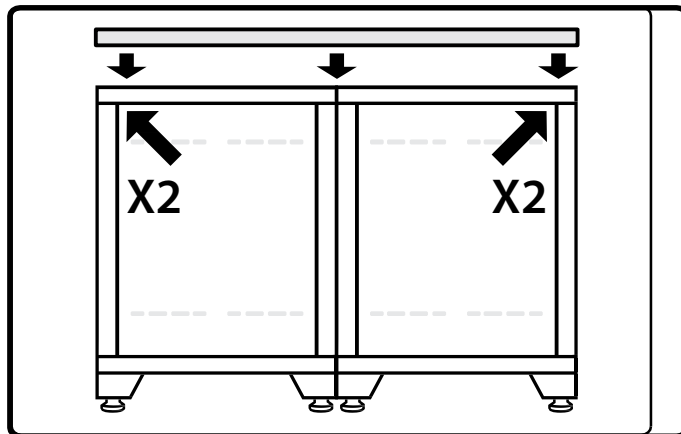

2 Drill into the worktop using the #8 x 5/8" woodscrews.

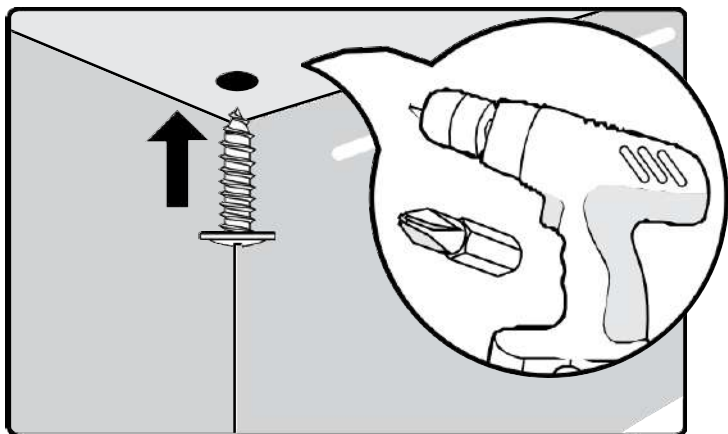

3

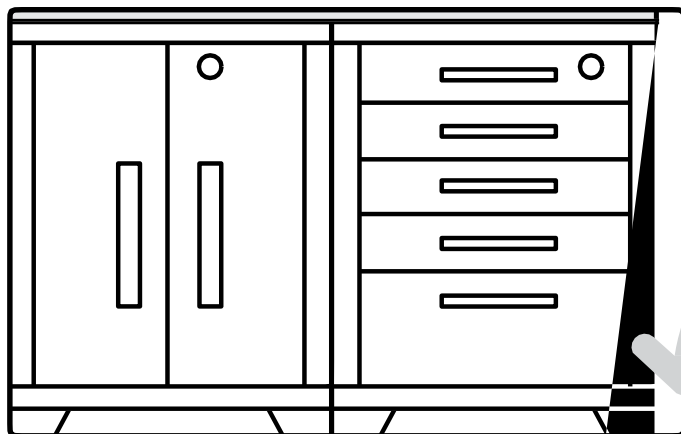

i Optional: For locker support bracket. See [Page 22](#).

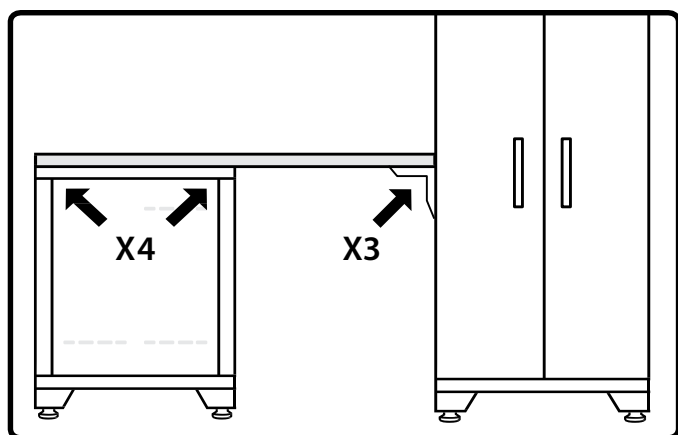

Installing Worktop Side Support Bracket

Note: Support Bracket included with Lockers
A support bracket is to be used if the worktop is added to the set without a secondary supporting base/tool cabinet.

i Parts Needed.

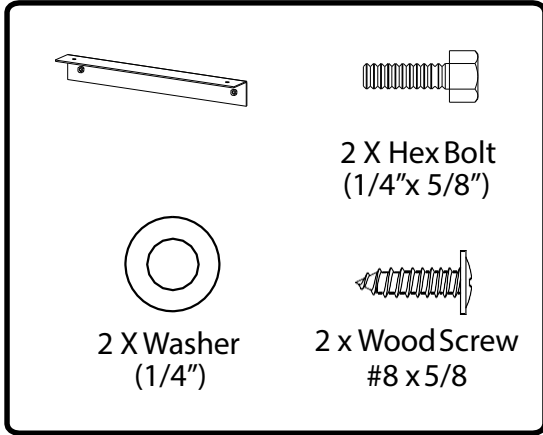

1 Open locker doors and locate holes on side panels.

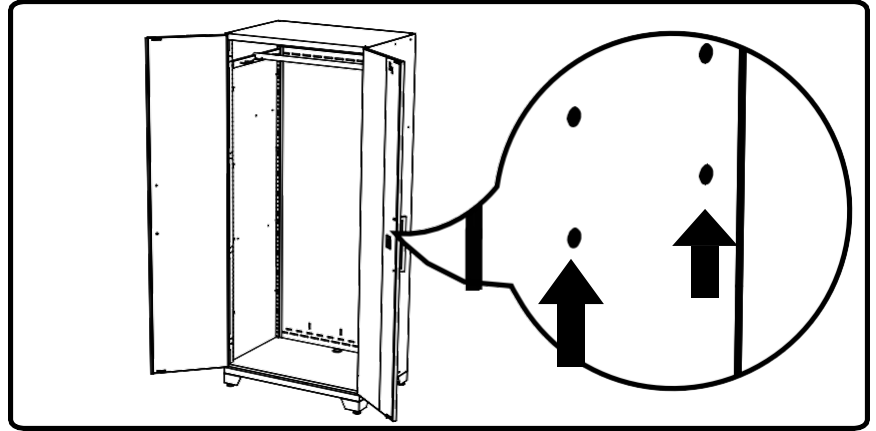

2 Align bracket holes with locker holes and insert hex bolts through holes.

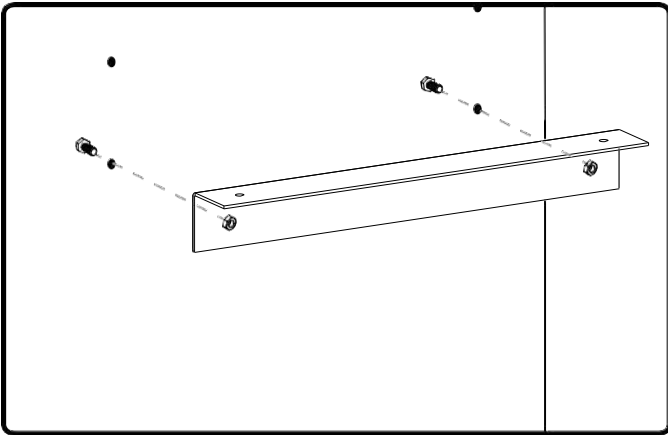

3 Tighten nuts & bolts.

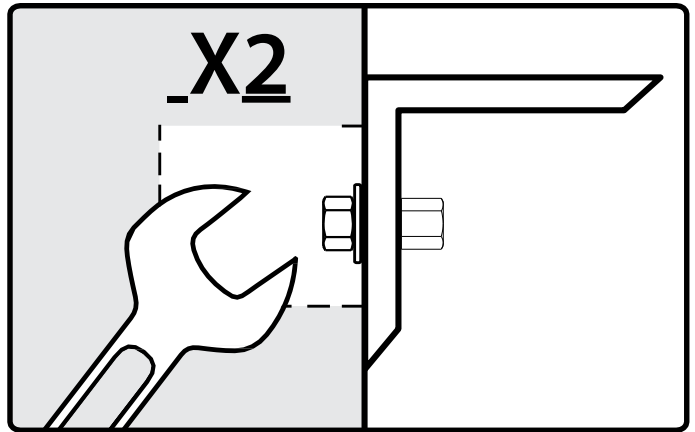

4 Use #8 x 5/8" wood screws and washers, provided in the locker packaging.

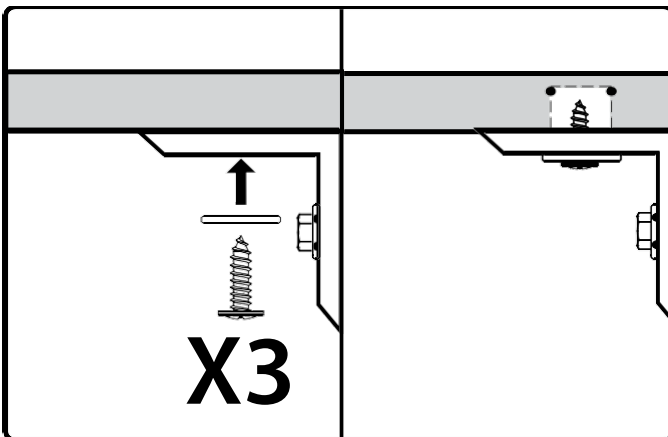

Installing Worktop Side Support Tray

i Parts Needed.

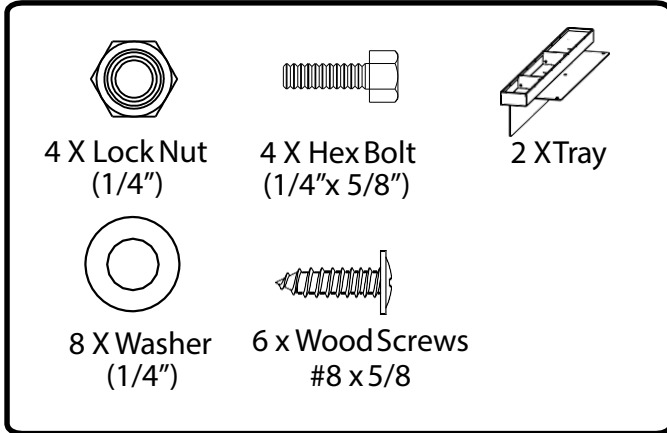

1 Open locker doors and locate upper holes on side panels.

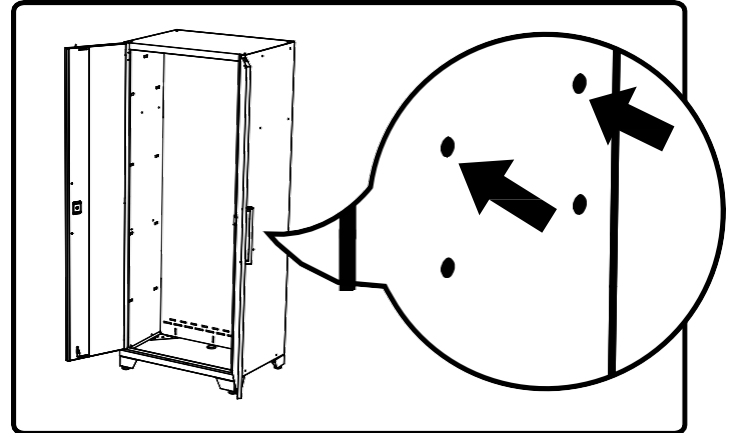

2 Align bracket holes with front or back of locker and insert hex bolts through holes.

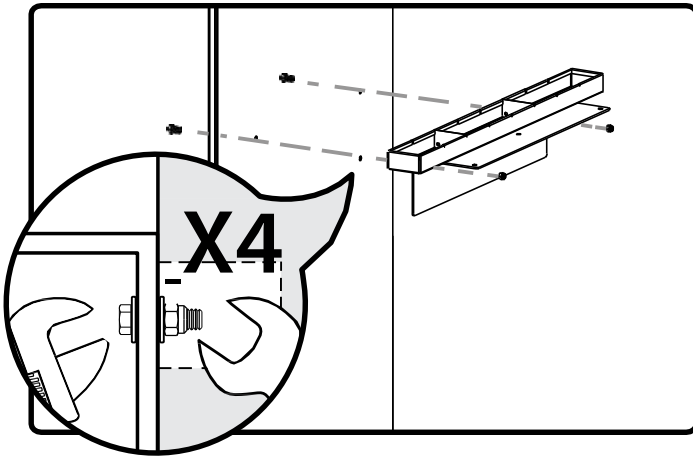

3 Repeat Steps 1-2 for 2nd side tray.

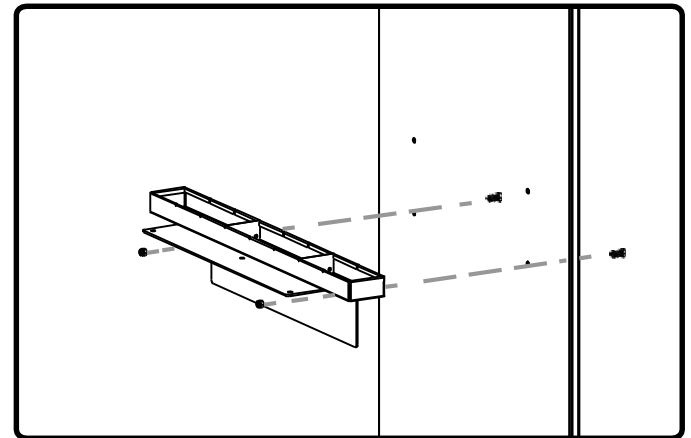

4 Lower worktop into position and attach using (6) - #8 x 5/8" screws.

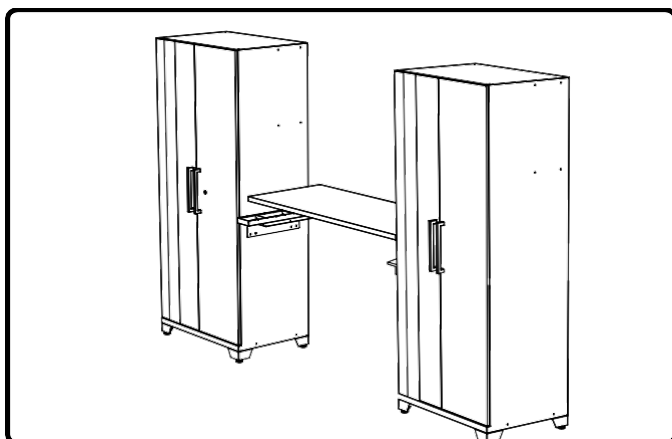

5 Install worktop wall supports in to the wall studs below the worktop using 2.5" lag screws with 3/16" pilot holes.

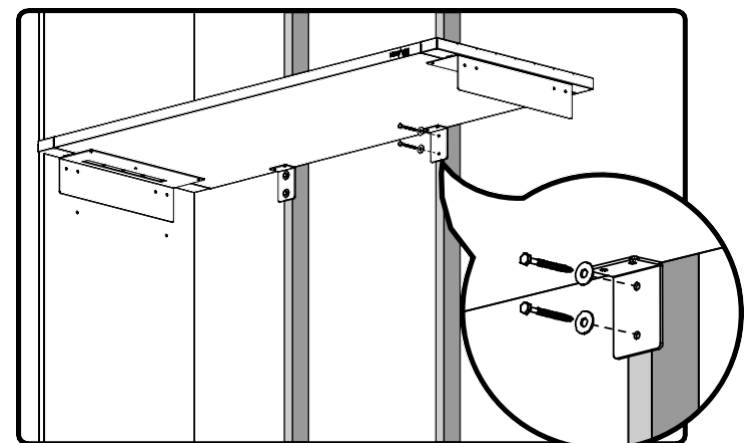

Installing Worktop Support Leg

i **Parts Needed.**

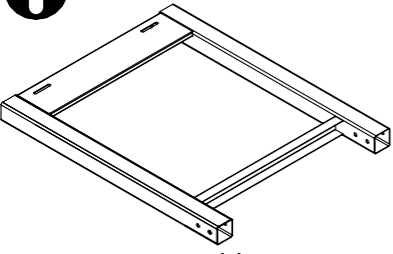

Leg Assembly

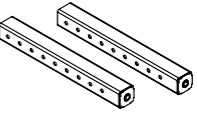

2x Leg Post

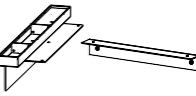

Worktop Tray or Side Support (Sold Separately)



4x Washer (M8) 2x Hex Bolt (M8 x 60mm) 2x LockNut (M8) 3x Woodscrew (#8 x 5/8")

1 Insert threaded feet and adjustable leg posts at desired height and secure using M8 x 60mm bolts, nuts, and washers provided.

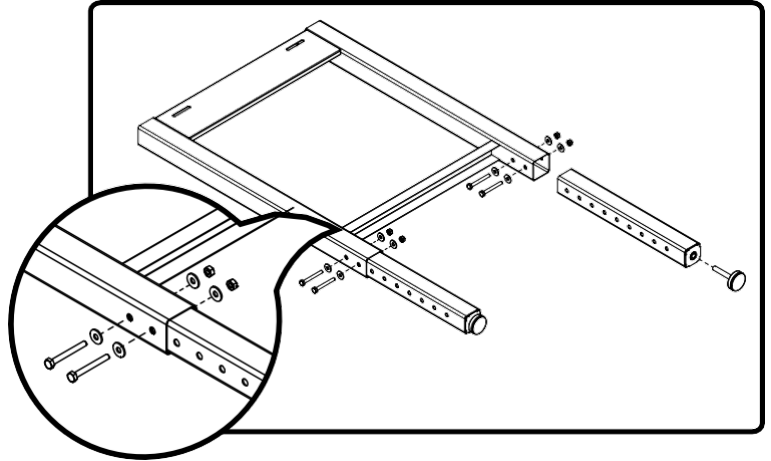

2 Determine the desired installation option A, B or C and attach Side Support Bracket or Spacer Tray to Worktop Support Legs.

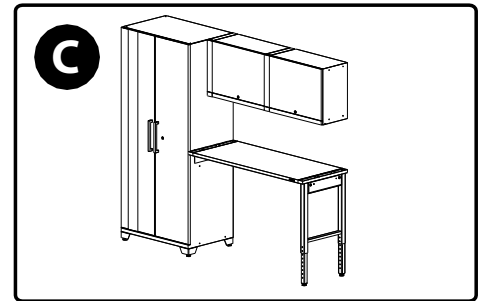
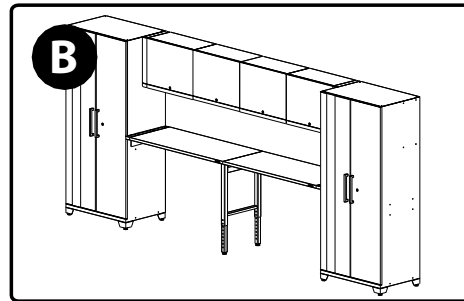
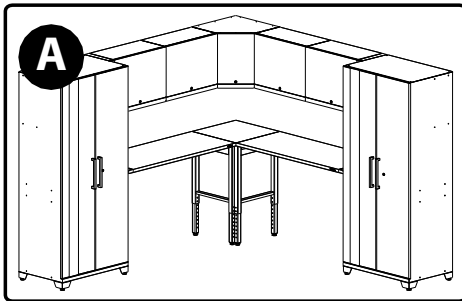

For installation option A or B, Attach Worktop Support Legs to side support bracket using 2x Hex Bolts (1/4" dia x 5/8") and washers.

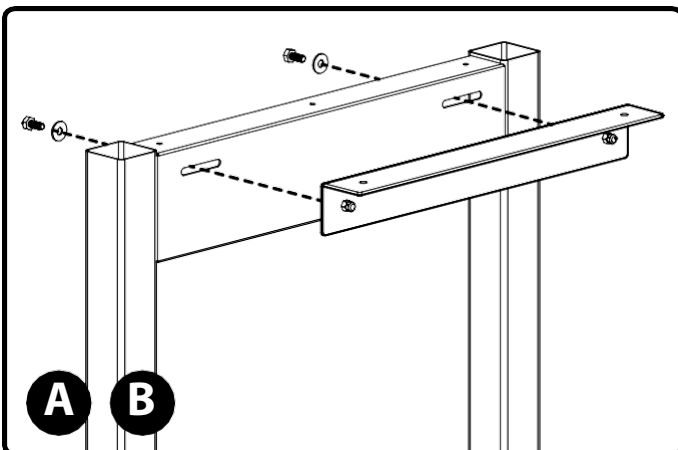

For Installation Option C, Attach Worktop Support Legs to Spacer Tray using 2x Hex Bolts (1/4" dia x 5/8"), washers, and locknuts.

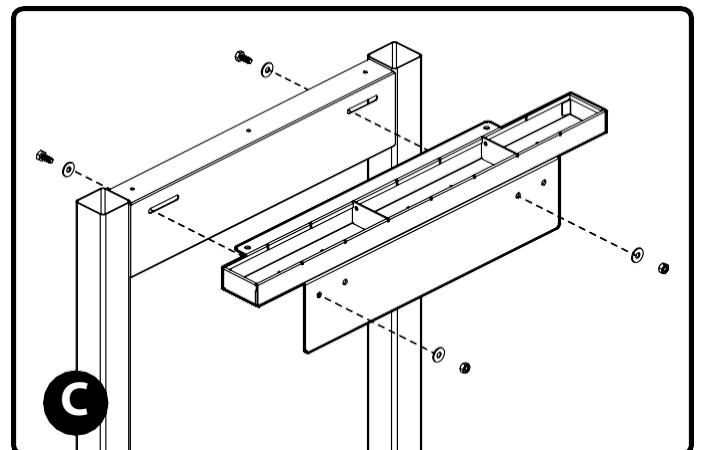

3 Attach the Worktop Leg Support to the Worktop using the #8 - 5/8" Philips Head Screws.

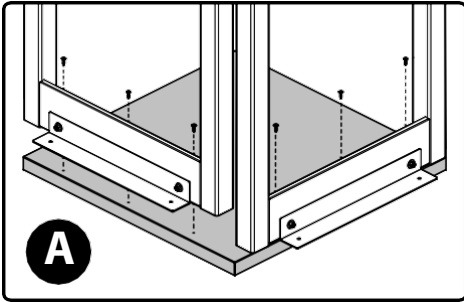

Installation option A:
Attach one Worktop Support Leg on each of the front edges on the Corner Worktop. The Worktop Support Legs should be flush along the sides and back of the worktop

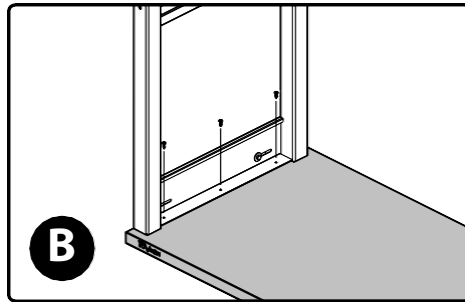

Installation option B:
Attach one Worktop Support Leg flush to the end of one of the two worktops.

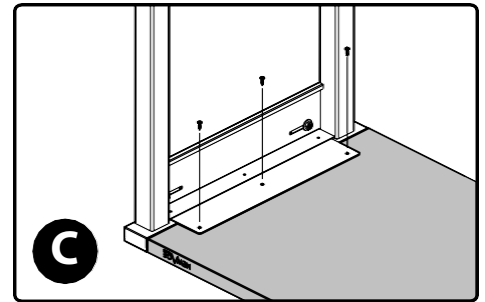

Installation option C:
Attach the Worktop Tray, flush with the end of the worktop.

4 Rotate remaining worktops into position and attach worktop to the support bracket using #8 x 5/8" screws. If there are no additional worktops to install, proceed to Step 5.

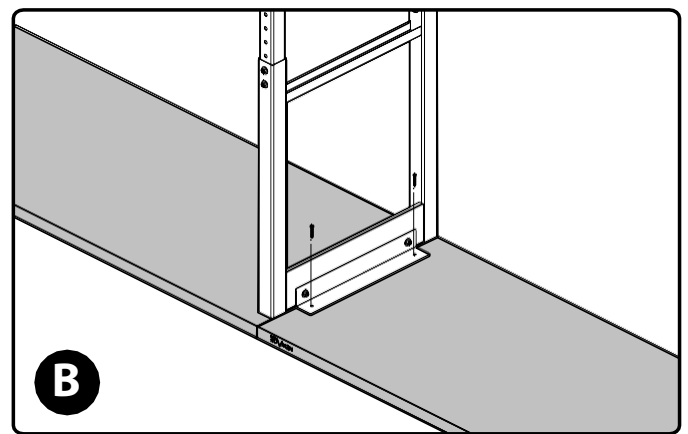
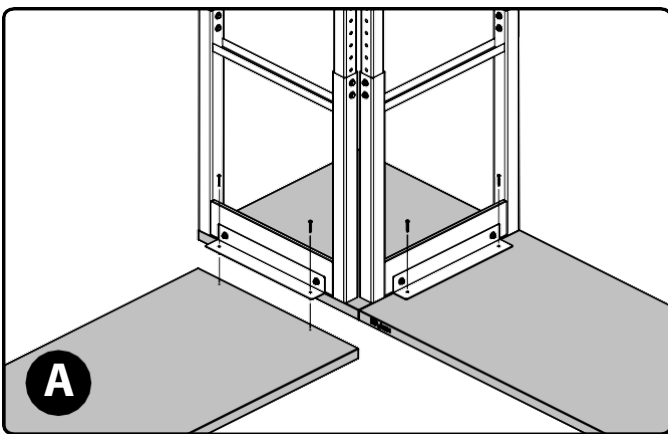

5 Follow "Installing Worktop Side Support Tray" instructions on [page 23](#) to secure the other end of the worktop(s).

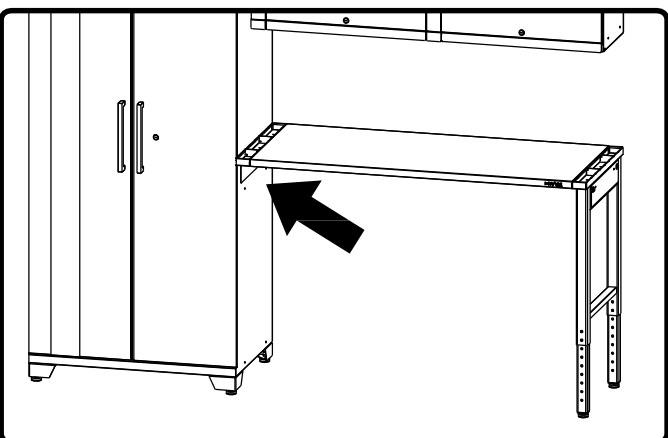

6 Install worktop wall supports into the wall studs below the worktop using 2.5" lag screws with 3/16" pilot holes.

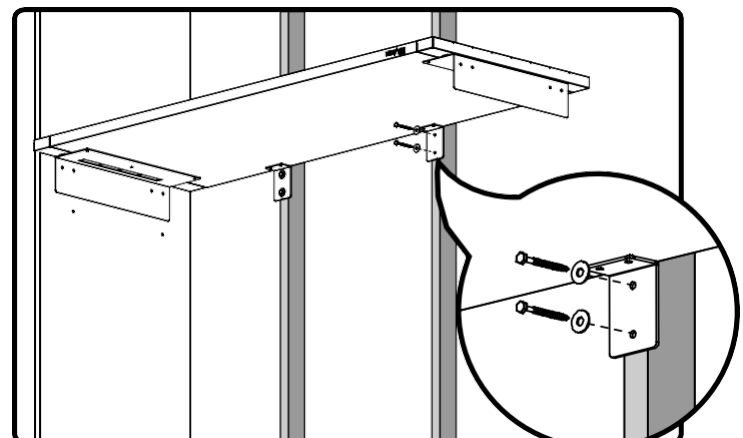

Installing Corner Worktop

i Parts Needed.

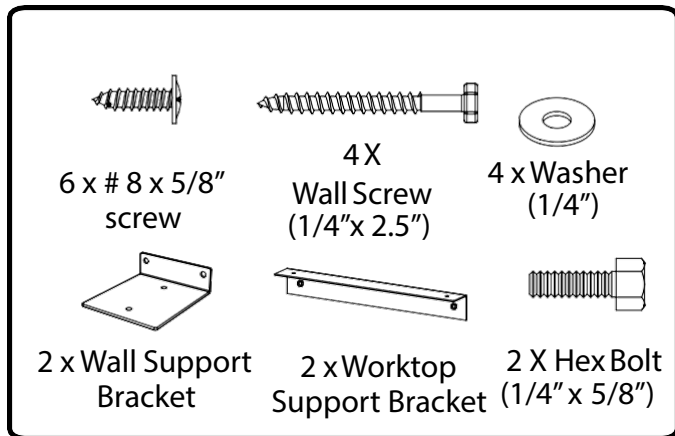

2 Position both cabinets in desired corner. Locate studs and mark a level pencil line at height of cabinets.

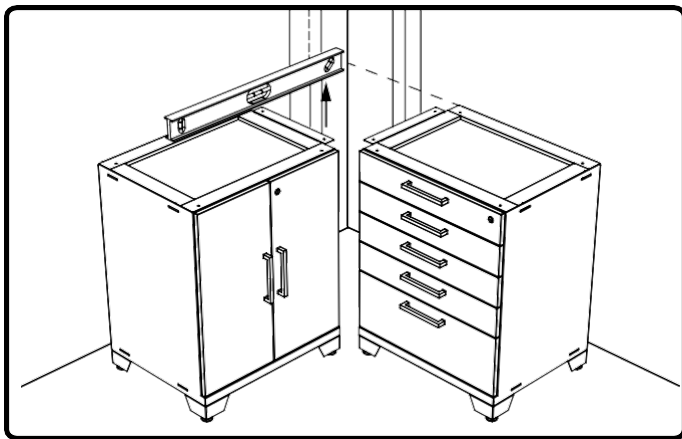

4 Position one cabinet into position and attach corner worktop to brackets.

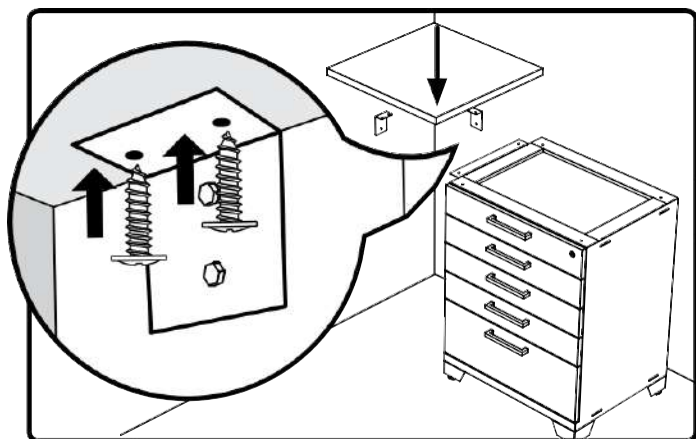

1 Install Side Support Brackets on the two base cabinets that will be adjacent to corner worktop. See Step 2 in side support brackets on [page 22](#).

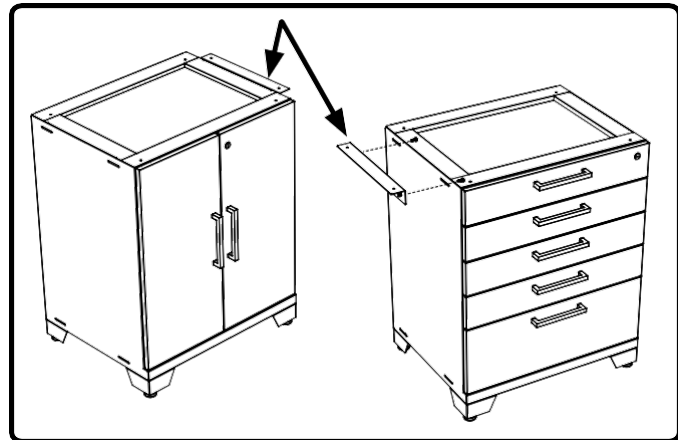

3 Align top of wall support bracket with pencil line and using 2.5 lag screw attach corner wall support brackets into wall studs.

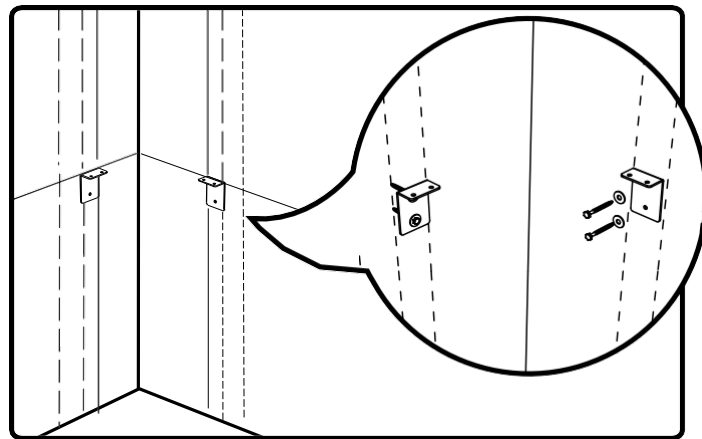

5 Attach remaining cabinets and countertops.

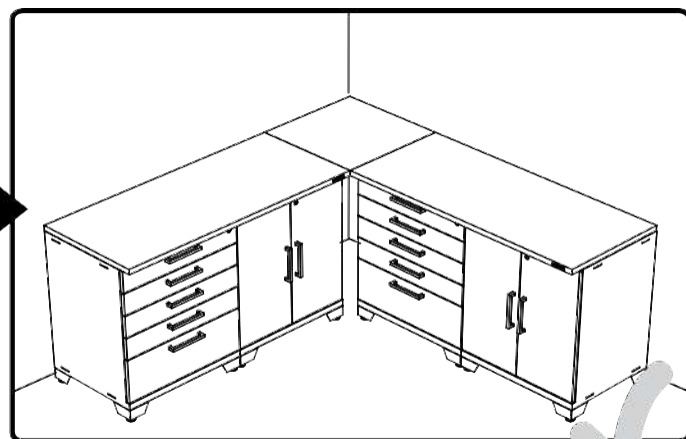

Installing Feet

i Parts Needed.

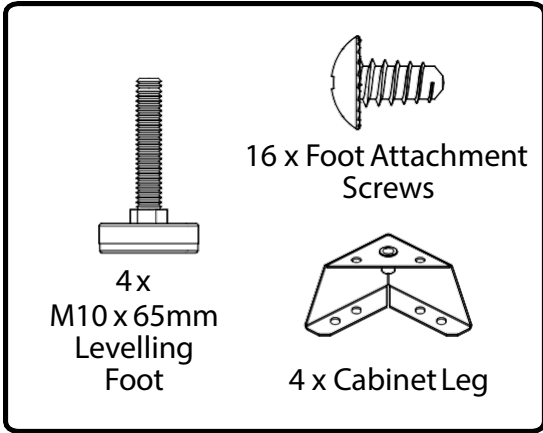

1 Open cabinet, remove any shelves, drawers or loose items.

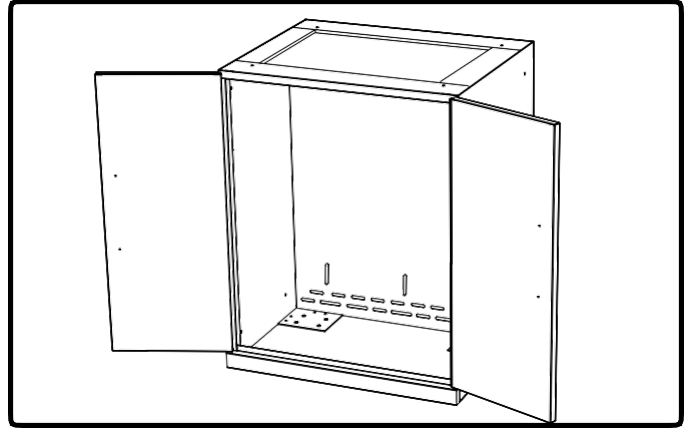

2 Flip cabinet upside down, locate holes at corners.

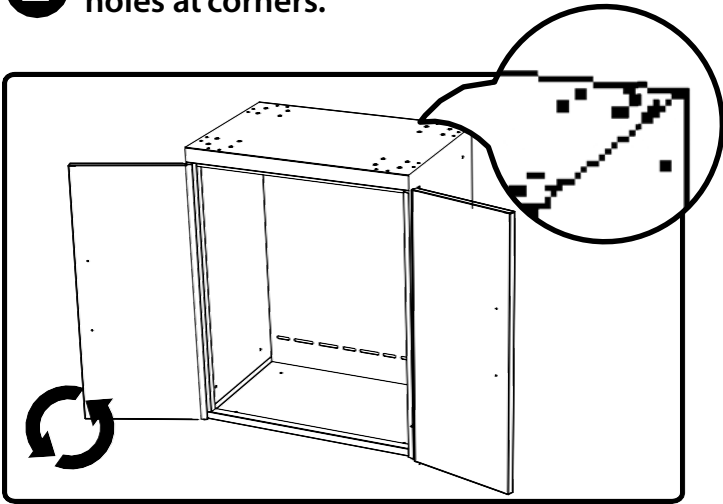

3 Align leg with edge of cabinet. Screw in 4 x Foot attachment screws & leveling foot.

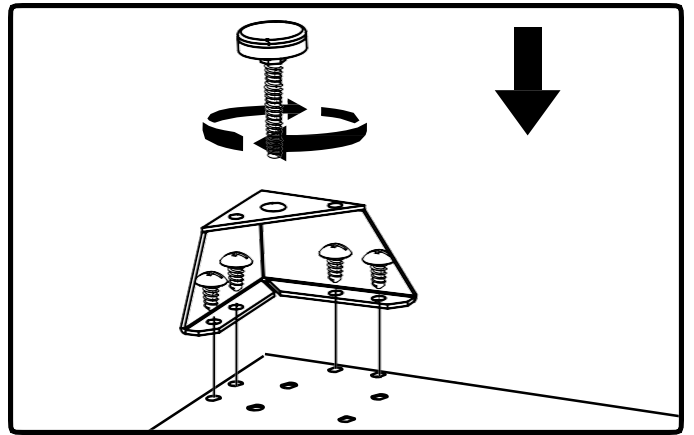

4 Repeat steps 3 for each corner.

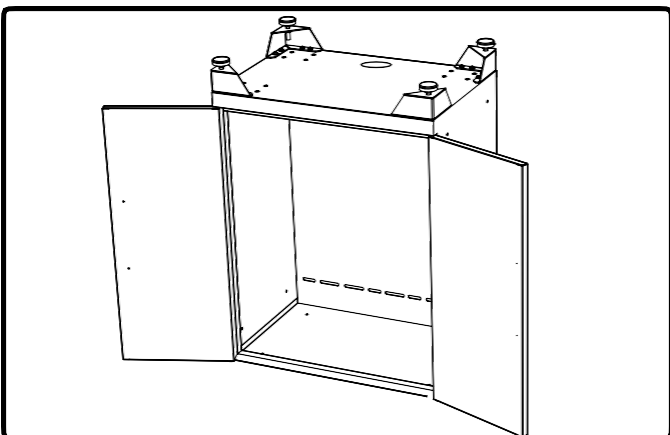

5 Stand & level feet.

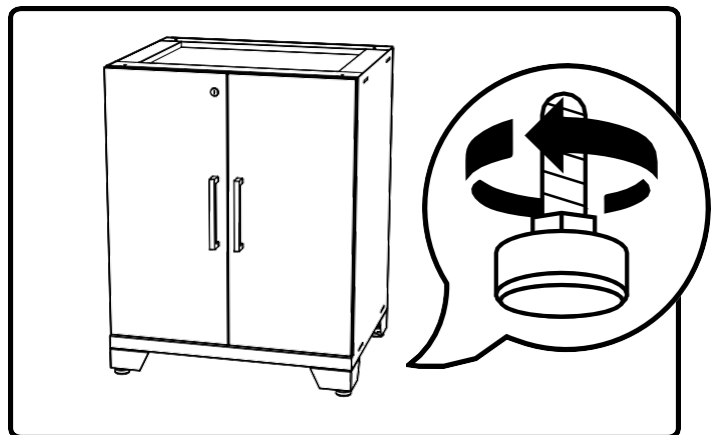

Installing Casters

Note: Install casters with step brake on front side of cabinet.

Warning: Always lock casters when not in use.

i Parts Needed.

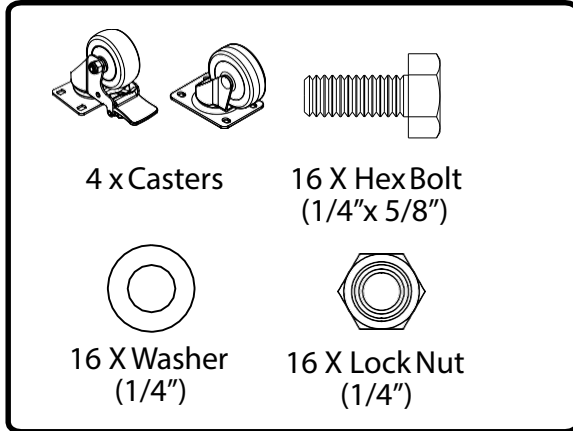

1 Open cabinet, remove any shelves, drawers or loose items.

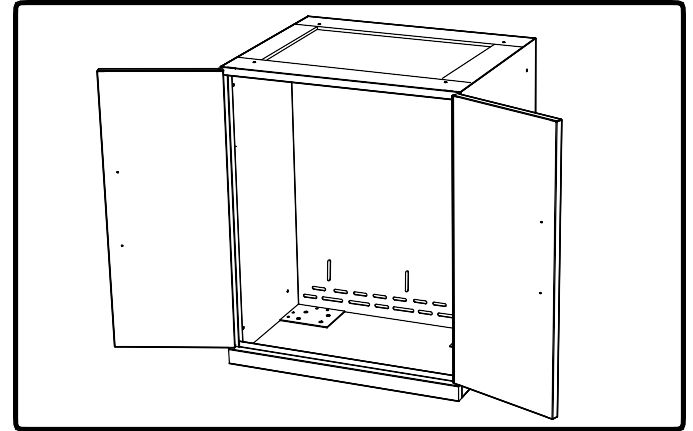

2 Flip cabinet upside down, locate holes forming a square.

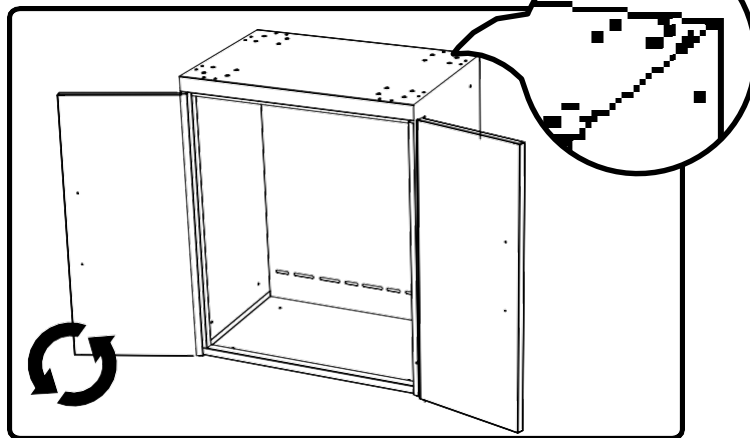

3 Align caster with holes. Attach with 4 hex bolts, washers, and nuts.

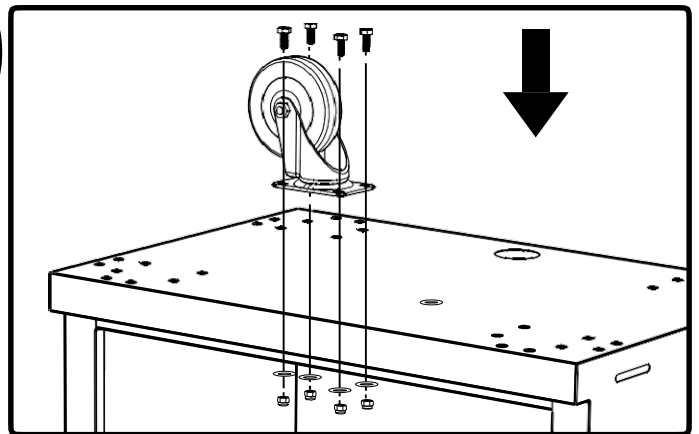

4 Repeat step 3 for each corner.

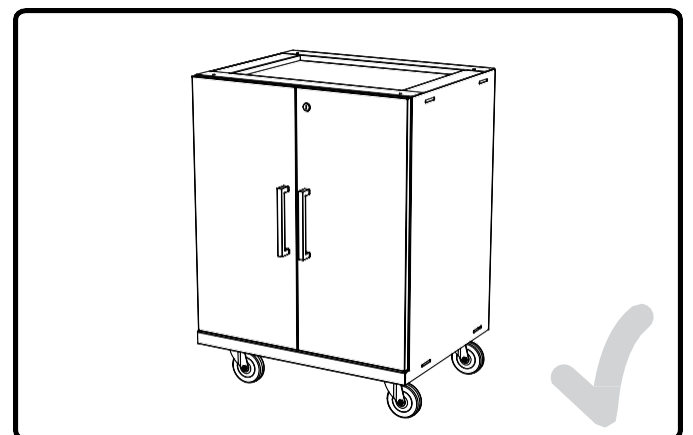
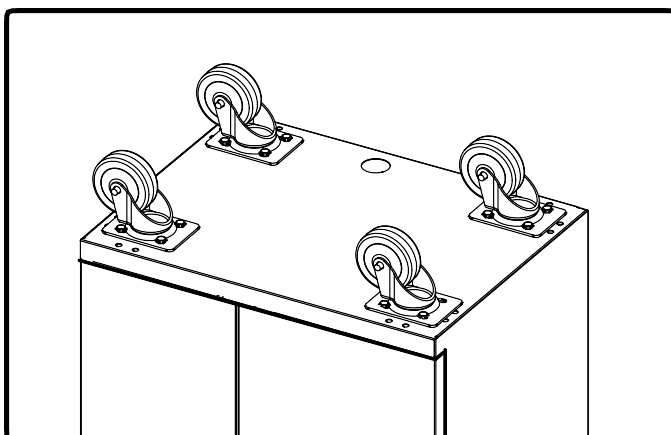

Installing the Drawers

Inserting Drawers.

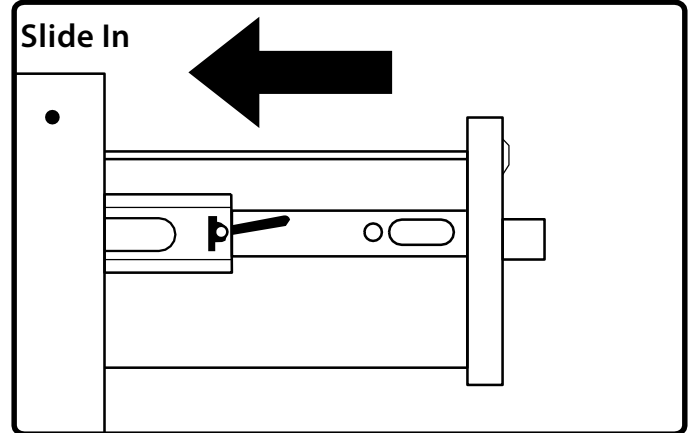
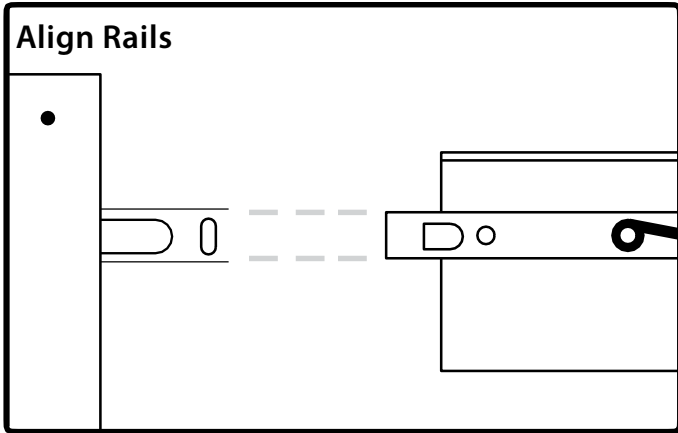

Removing Drawers.

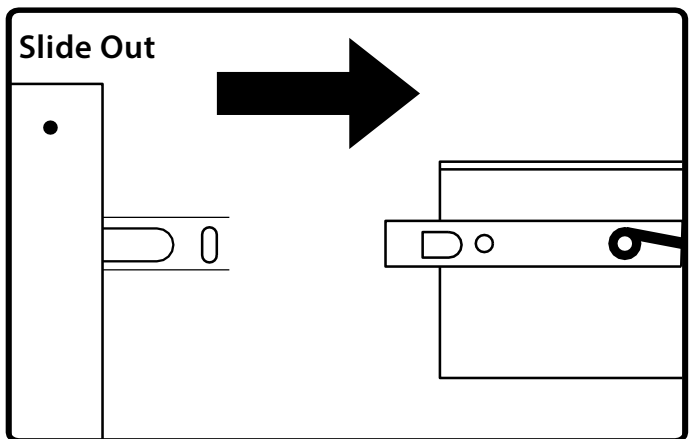
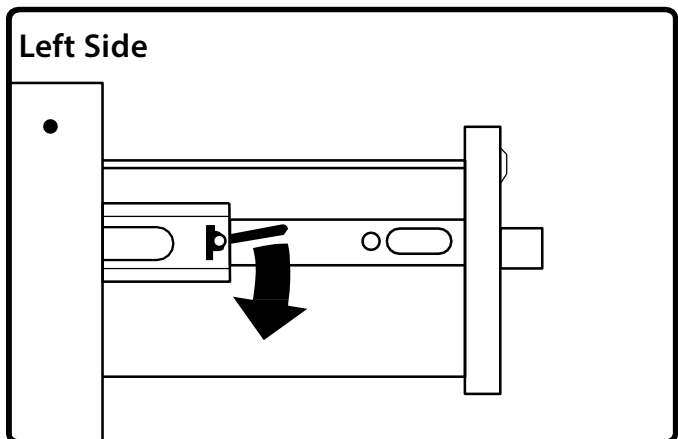
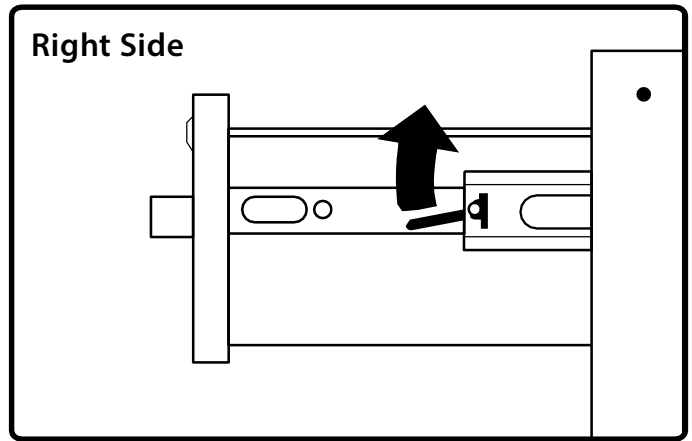
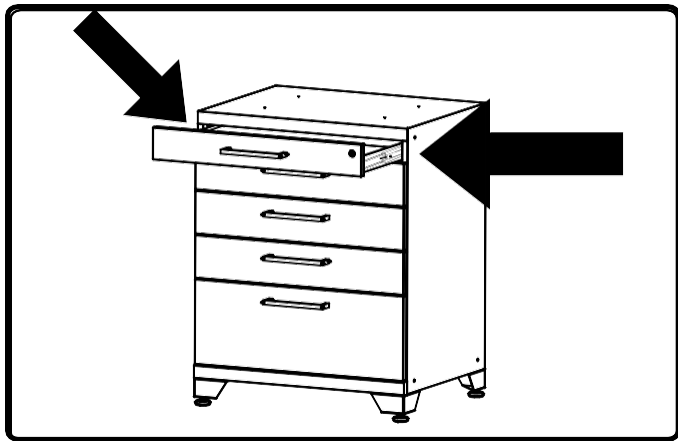

Installing Handles

1 Parts Needed.

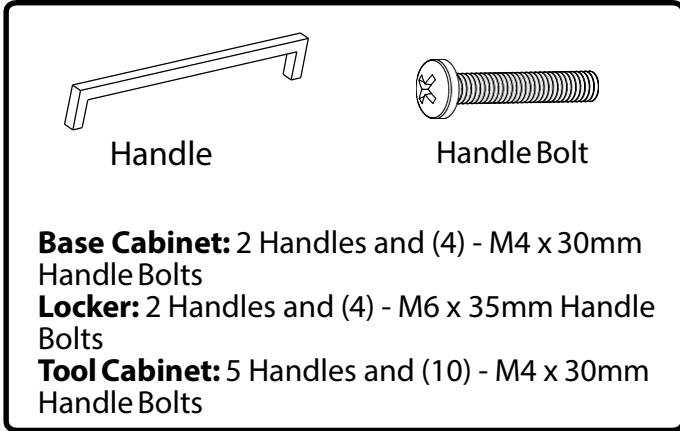

2 Align Handle to holes on doors or drawers.

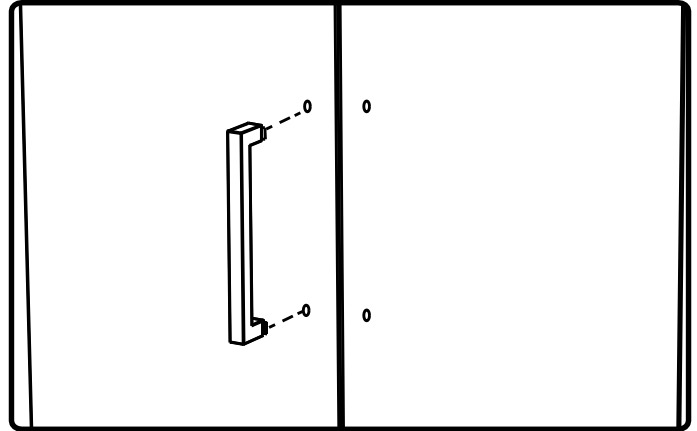

3 Screw in bolts.

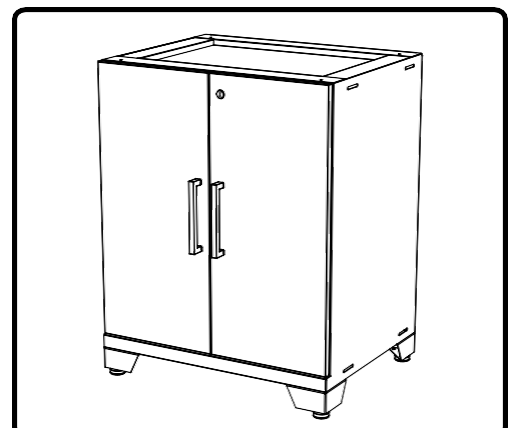
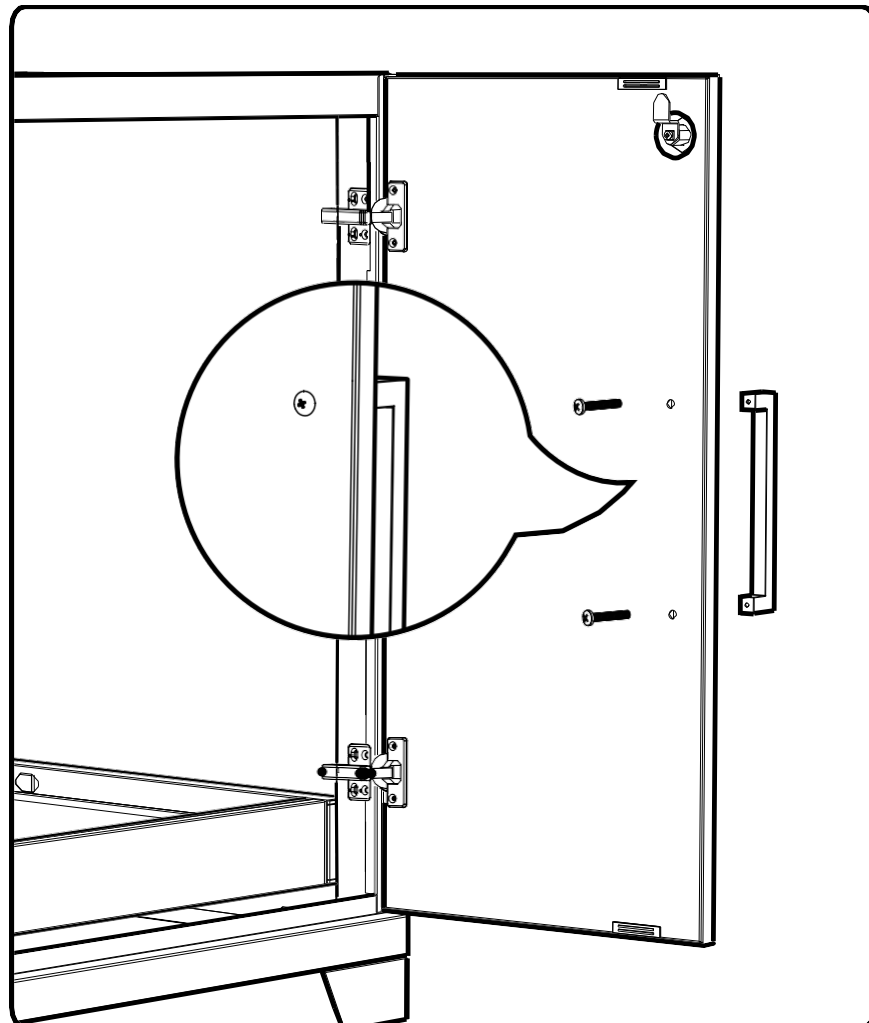

Stacking Cabinets

Note: Do not exceed weight capacity of feet.
See [page 5](#).

i Parts needed.

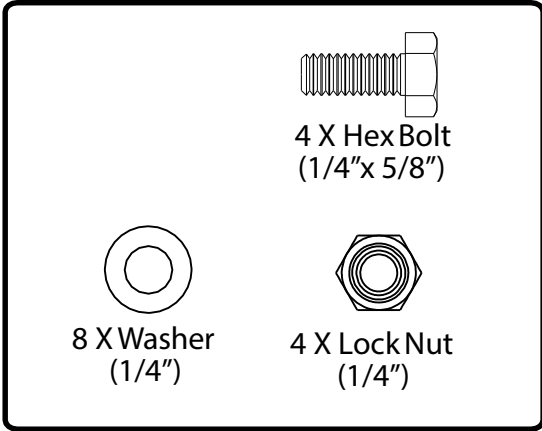

1 Position a second base cabinet on top of an existing base cabinet.

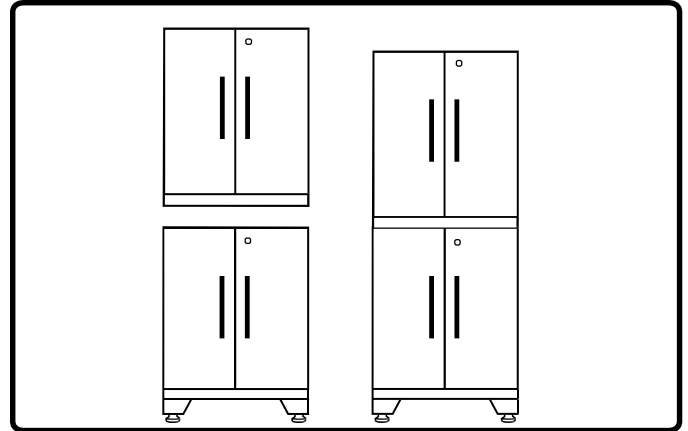

2 Locate punch holes on adjoining surface and insert bolts.

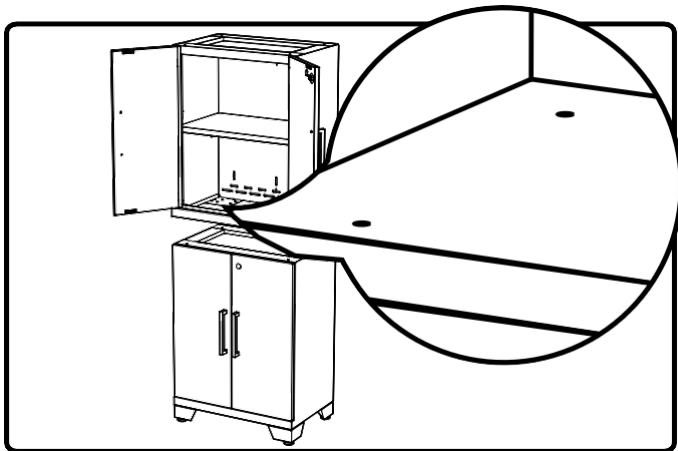

3 Attach cabinets using the supplied 1/4" x 5/8" hex bolts, washers, and nuts.

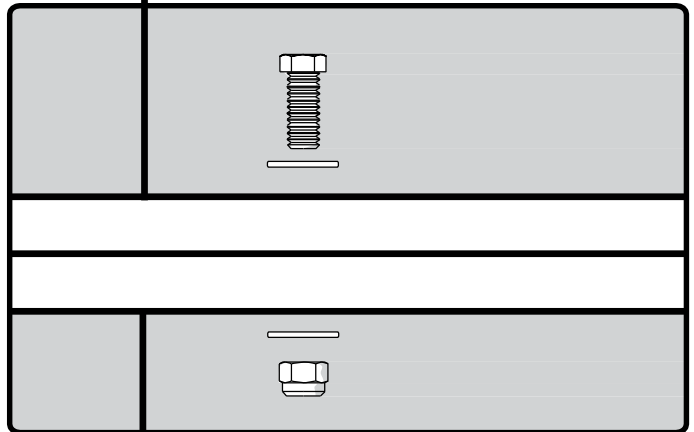

4 Tighten all bolts.

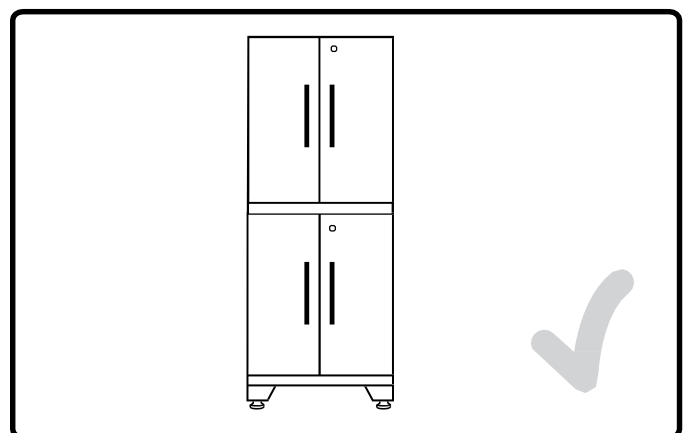
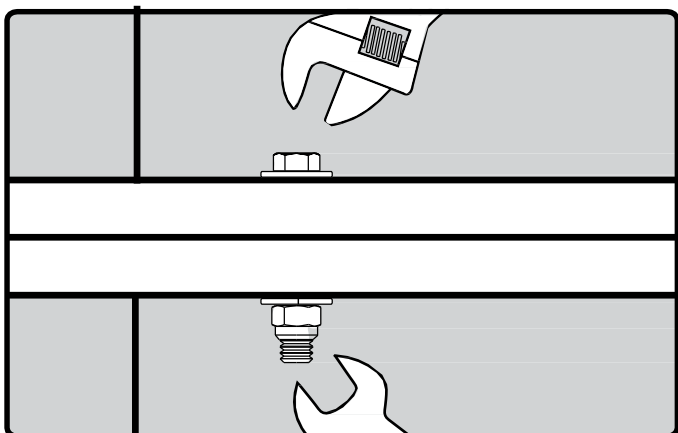

Inserting Locker Utility Rod and Hangars

1 Parts needed.

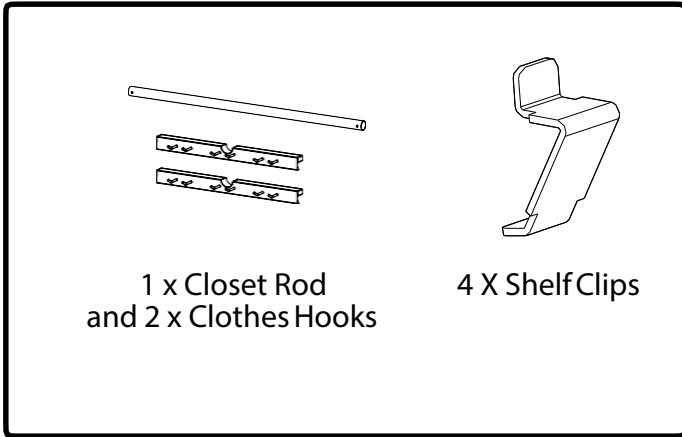

2 Open cabinet doors and insert shelf clips into slots in corners. Rotate to engage.

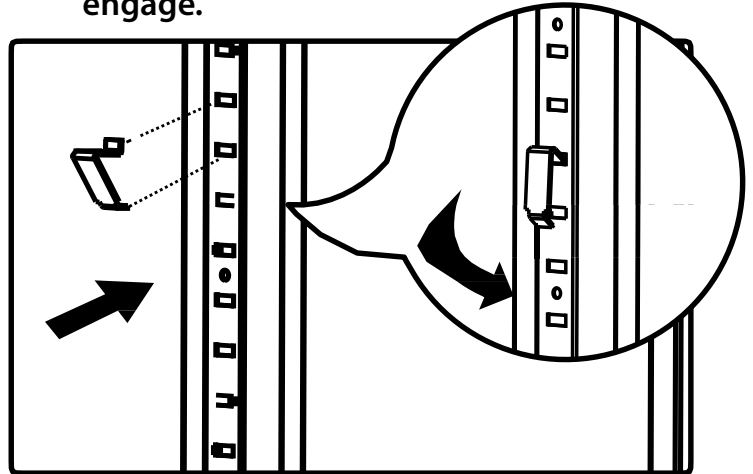

3 Place clothes hook against locker wall above supports.

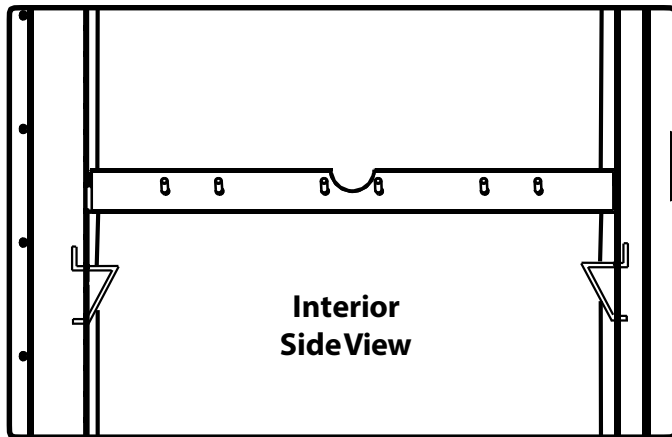

4 Ensure rear flange slides down behind clips and that the bracket is secure. Repeat steps 1-4 for second hooks.

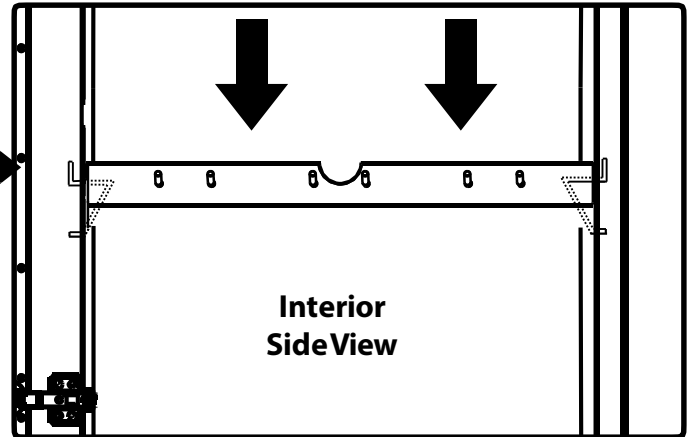

5 Lower closet rod into cradle.

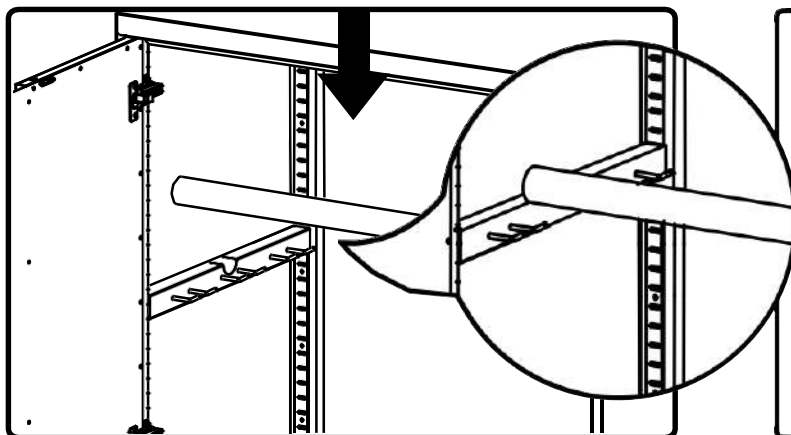

6

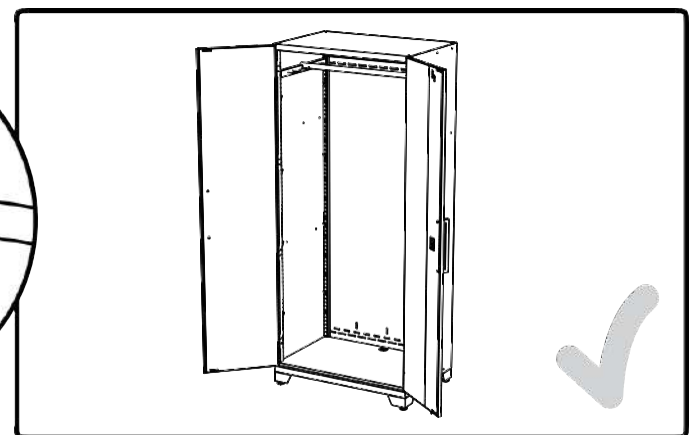

Inserting Cabinet Shelves

1 Parts Needed

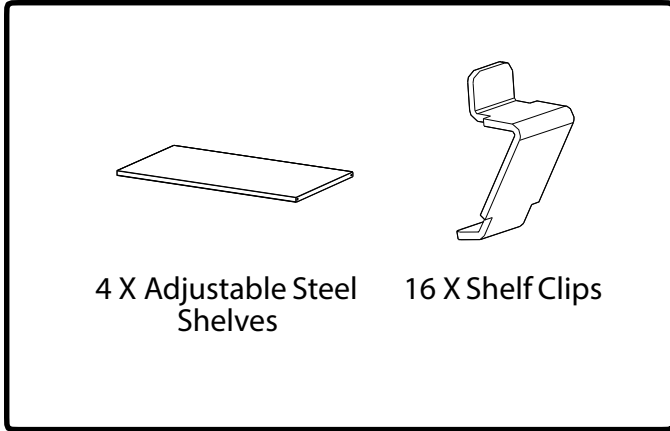

2 Open cabinet doors and insert shelf clip on slight angle and rotate to level position.

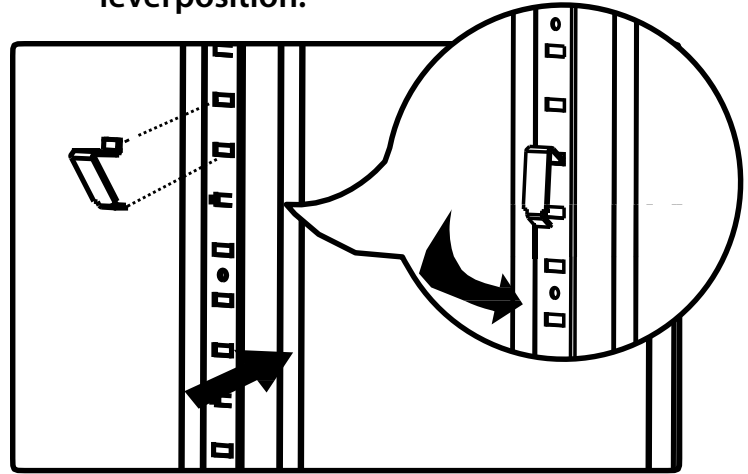

3 Insert shelf on a angle and rotate to level position.

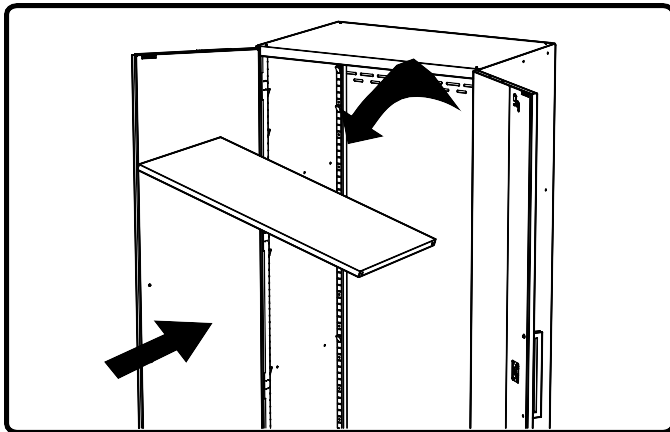

4 Lower shelf onto shelf clips.

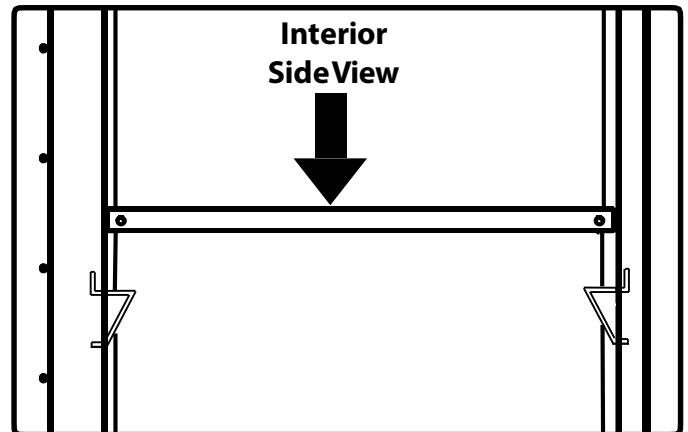

5 Rest shelf on shelf clips.

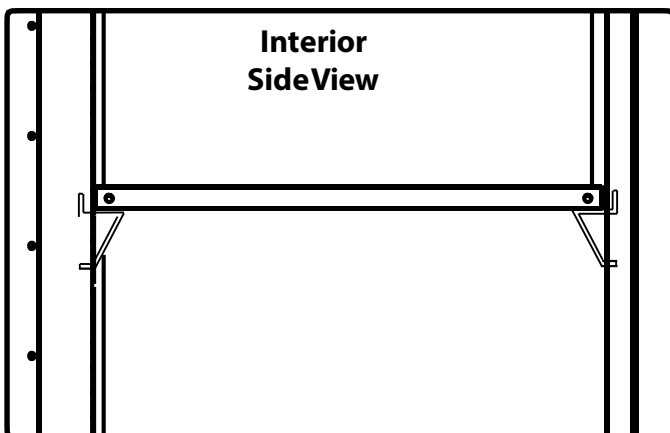

6 Insert remaining shelves.

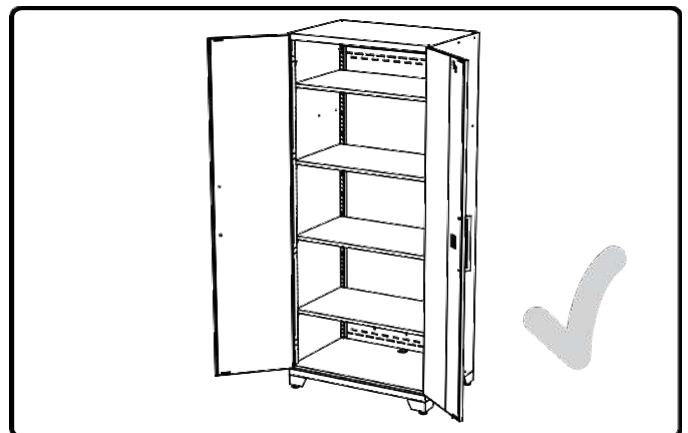

Adjusting Base Cabinet Pullout Shelf

- 1** Remove Pull-out shelf following instructions for removing drawers on [page 29](#).

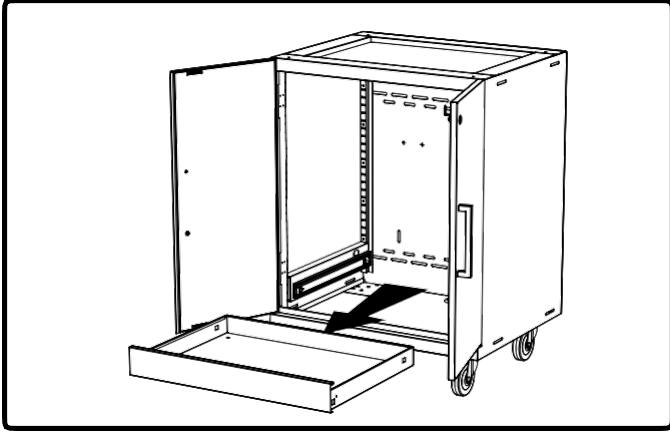

- 2** Locate hole (A) in drawer slide. Using finger depress and hold spring loaded button.

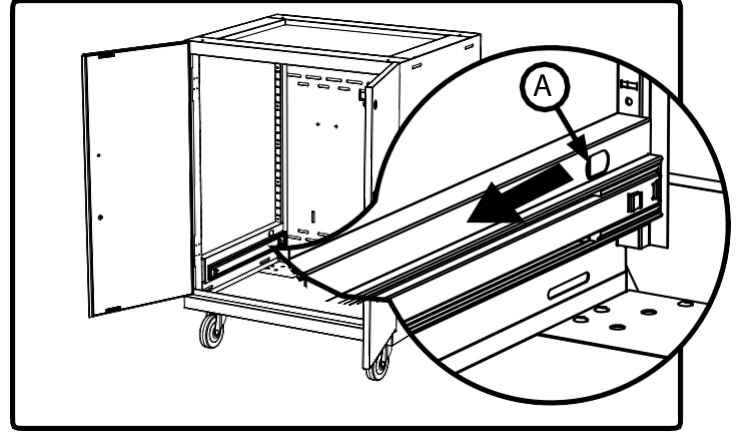

- 3** Swing drawer slide out from back of cabinet.

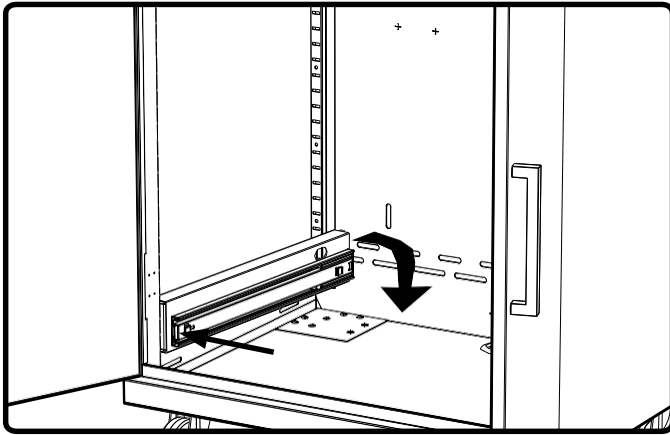

- 4** Pull drawer slide out and away from cabinet wall and move to desired height.

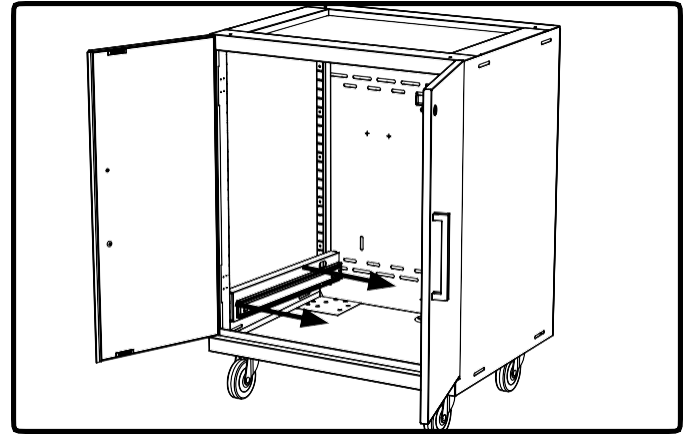

- 5** Insert drawer slide beginning at front. Ensuring the tabs in slide mount in slots on cabinet frame.

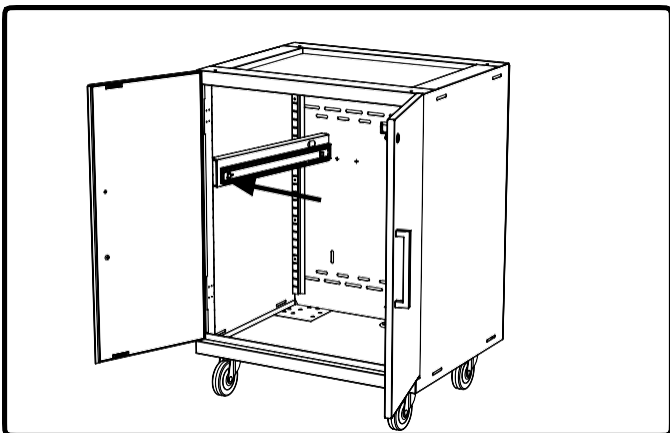

- 6** Swing drawer slide in at back of cabinet and release spring loaded button (A) ensuring it locks in place

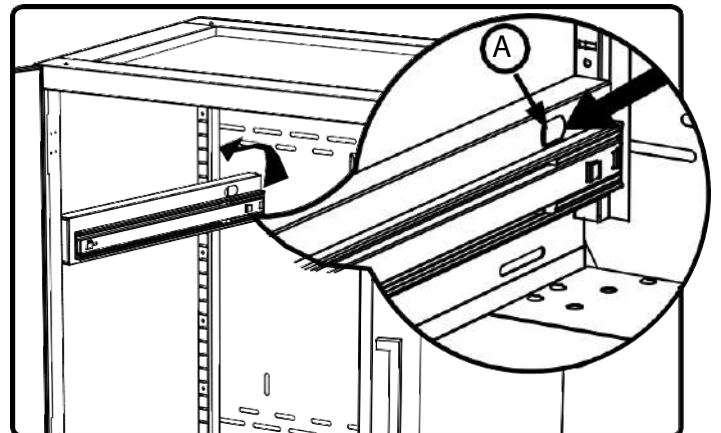

7 Repeat steps 2 - 7 for 2nd slide mount.

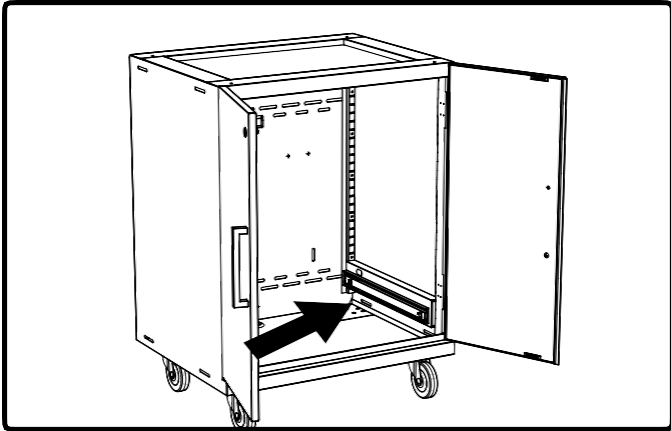

8 Reinstall Pull-out shelf following steps from [page 29](#).

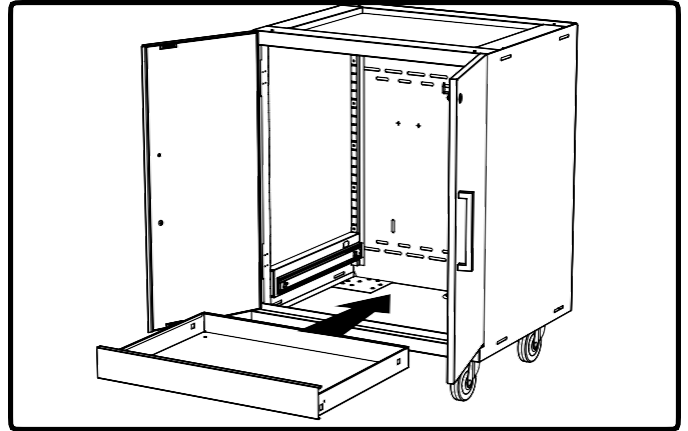

Utility Access

1 Insert rubber grommet into cut-out hole in bottom panel.

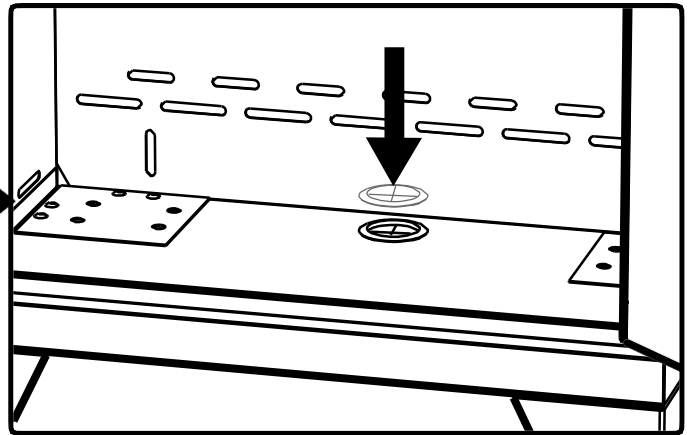
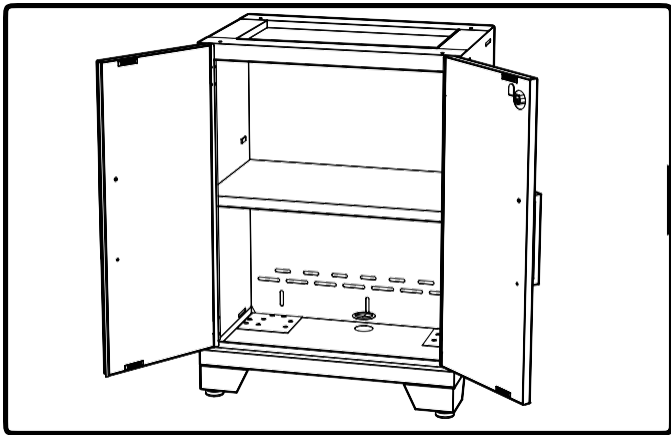

2 Using box knife cut along perforation in rubber grommet to create hole. Utility hole allows easy access to electrical outlet.

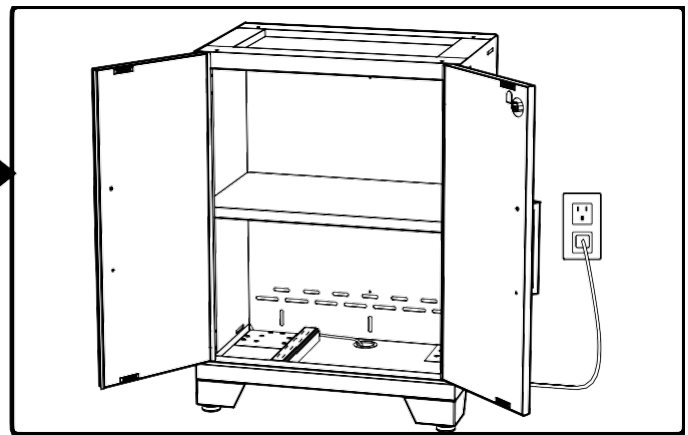
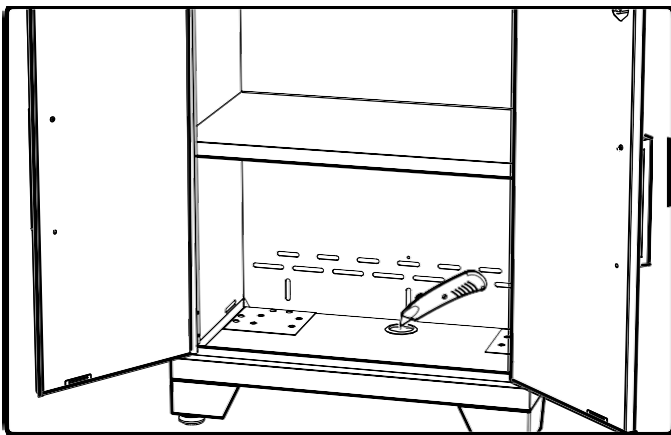

Magnetic Racing Stripe

Note: Racing stripe not available for Diamond Plate doors.

i The Racing Stripe can be installed on either door of locker. To remove stripe follow steps 1-3.

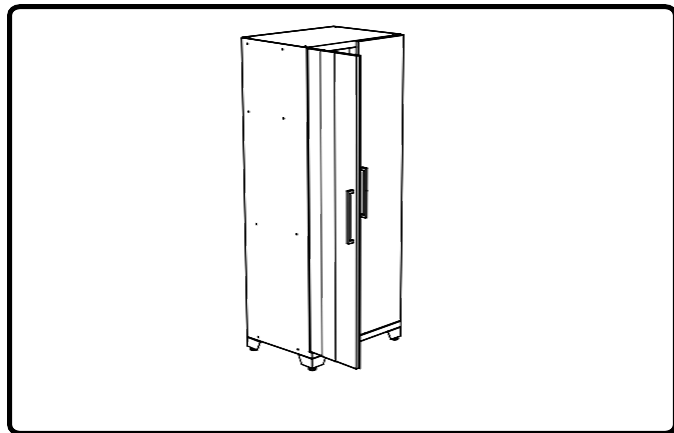

1 Remove the 2 plastic plugs holding in the racing stripe at the top of door.

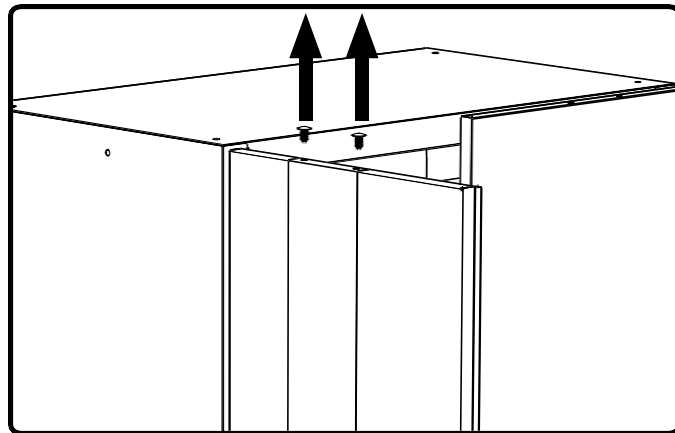

2 Tilt stripe off top of door.

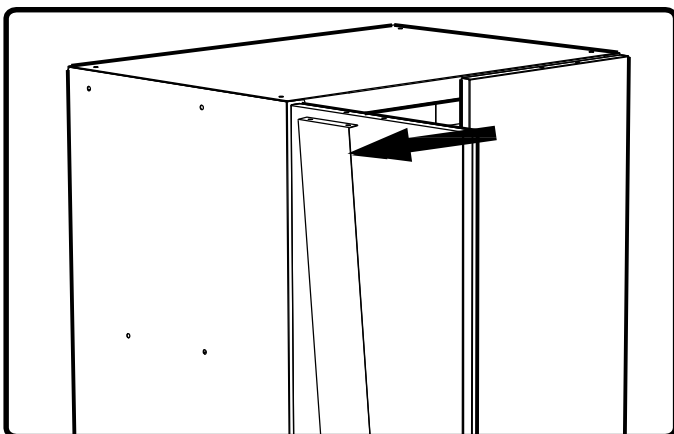

3 Lower and remove from slot on bottom of door.

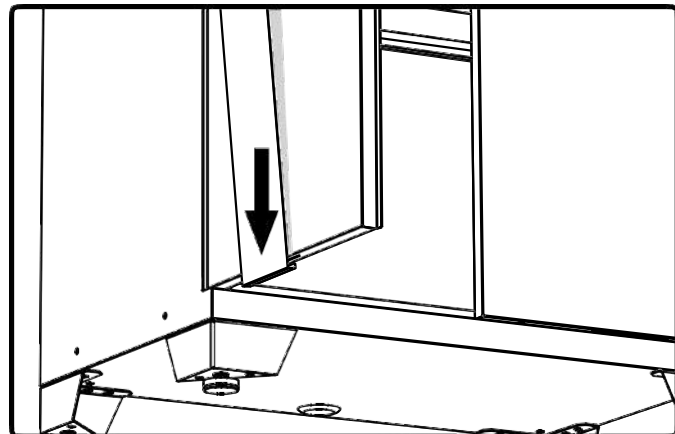

4 Attach Racing Stripe on opposite door following reverse order.

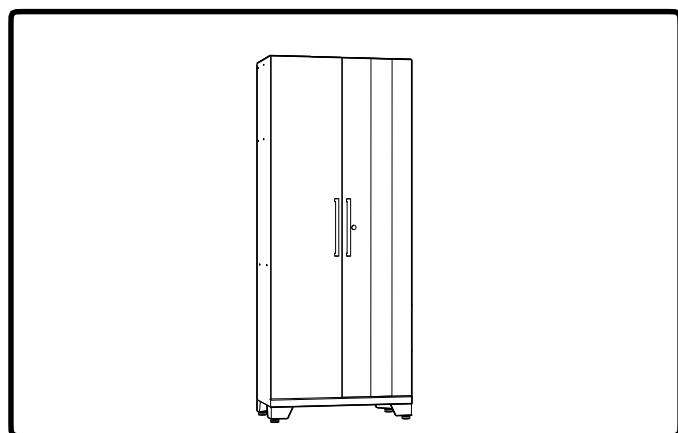

i **HANDLE WITH CARE:** Racing Stripe can easily bend and crease.

Adjusting The Door Hinges

Using a Philips screwdriver, the doors can be adjusted:
Left, right, forwards and backwards, or up or down.

- 1** To adjust the doors in or out from cabinet, turn the screw (A) clockwise or counterclockwise.

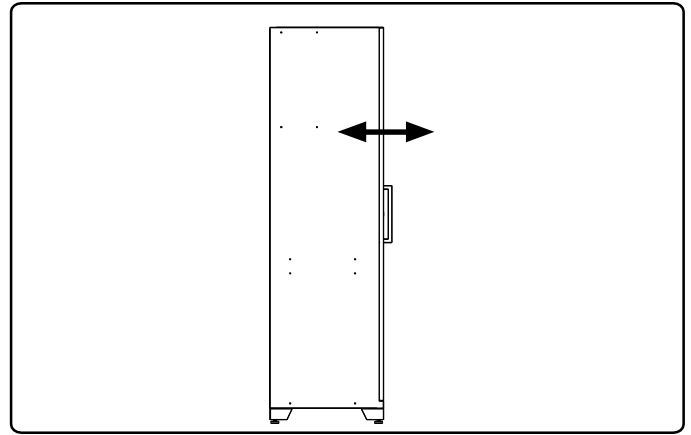
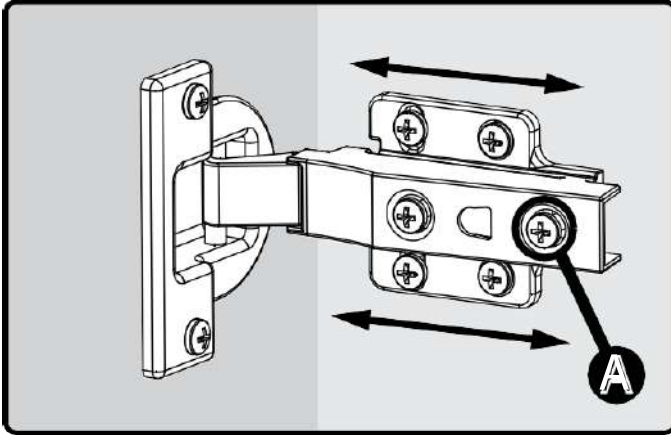

- 2** To adjust the doors left or right, turn the screw (B) clockwise or counterclockwise.

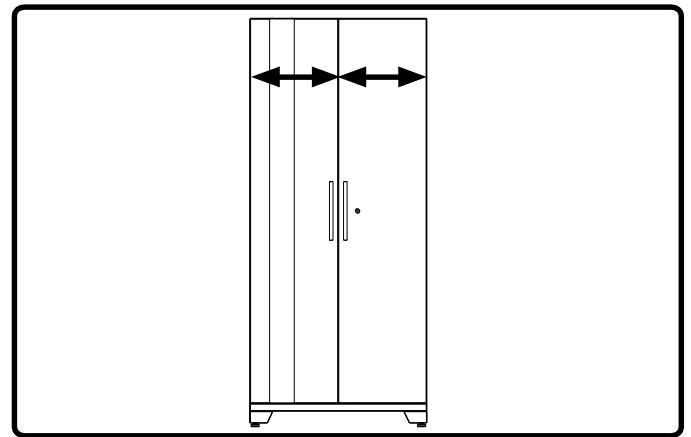
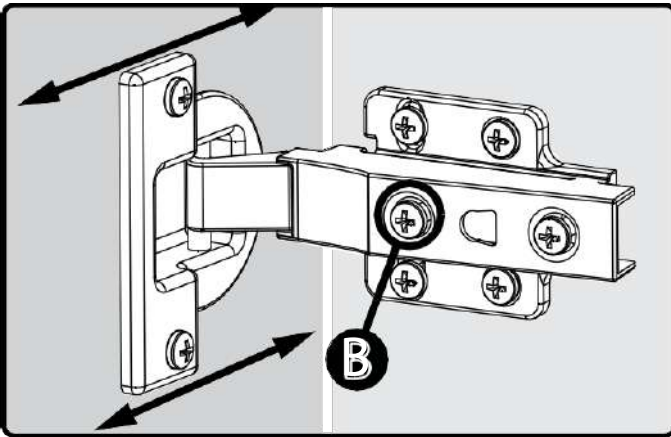

- 3** To adjust the door vertically, turn the screw (C) clockwise or counterclockwise.

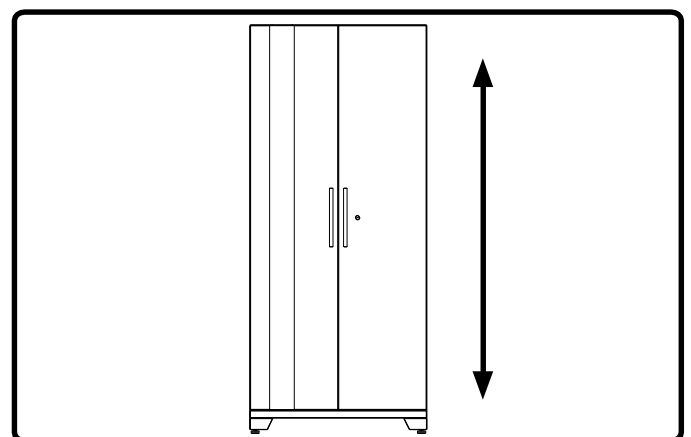
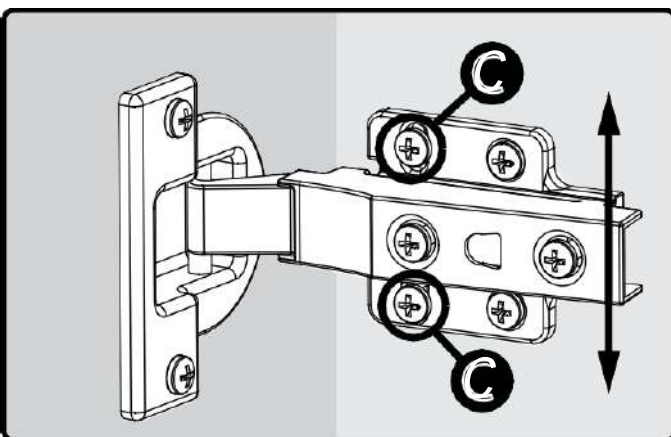

Limited Lifetime Manufacturer Warranty

When this product is installed, operated and maintained according to the instructions attached to or furnished with the product, NewAge Products Inc. will replace the defective product or parts if the part fails as a result of defective materials or workmanship for the Lifetime of the product.

NEWAGE PRODUCTS INC. WILL NOT PAY FOR:

1. Service calls to correct the installation of any NewAge products or to instruct you how to use or install them.
2. Damage resulting from improper handling or shipping of products, or products damaged by accident, misuse, abuse, fire, flood, improper installation, acts of God, neglect, corrosion, modification or mishandling.
3. Products damaged by improperly loading beyond the specified maximum weight capacity outlined in the instructions provided with the product.
4. Repairs or replacement when your product is used in other than normal, single-family household use, such as a commercial environment, or handled in anyway inconsistent with the installation instructions included with the product.
5. Cosmetic damage, including scratches, dings, dents or cracks in paint that do not affect the structural or functional capability of the product.
6. Surfaces damaged due to chemical interaction resulting in corrosion of paint or metal.
7. Replacement parts for NewAge products outside Canada and the United States.
8. Replacement keys or locking mechanisms.
9. Loss of product contents due to theft, fire, flood, accident or acts of God.
10. Shipping or freight fees to deliver replacement products or to return defective products.
11. Any labor costs during the limited warranty period.

DISCLAIMER OF IMPLIED WARRANTIES; LIMITATION OF REMEDIES

IMPLIED WARRANTIES, INCLUDING TO THE EXTENT APPLICABLE WARRANTIES OF MERCHANTABILITY OR FITNESS FOR A PARTICULAR PURPOSE, ARE EXCLUDED TO THE EXTENT LEGALLY PERMISSIBLE. ANY IMPLIED WARRANTIES THAT MAY BE IMPOSED BY LAW ARE LIMITED TO ONE YEAR, OR THE SHORTEST PERIOD ALLOWED BY LAW. SOME STATES AND PROVINCES DO NOT ALLOW LIMITATIONS OR EXCLUSIONS ON HOW LONG AN IMPLIED WARRANTY OF MERCHANTABILITY OR FITNESS LASTS, SO THE ABOVE LIMITATIONS OR EXCLUSIONS MAY NOT APPLY TO YOU. THIS WARRANTY GIVES YOU SPECIFIC LEGAL RIGHTS, AND YOU MAY ALSO HAVE OTHER RIGHTS WHICH VARY FROM STATE TO STATE OR PROVINCE TO PROVINCE

Thank you for purchasing a NewAge Product!

Please give us a call or visit online if you have any questions.

Call 1.877.306.8930; for UK 0800.031.4069; e-mail at info@newageproducts.com