

OFFICE CHAIR SAFETY GUIDELINES

FGI-FC18011

**Recommended Maximum
Weight Capacity: 250lbs**

When adjusting the chair height upwards or downwards, gently push up on the lever.

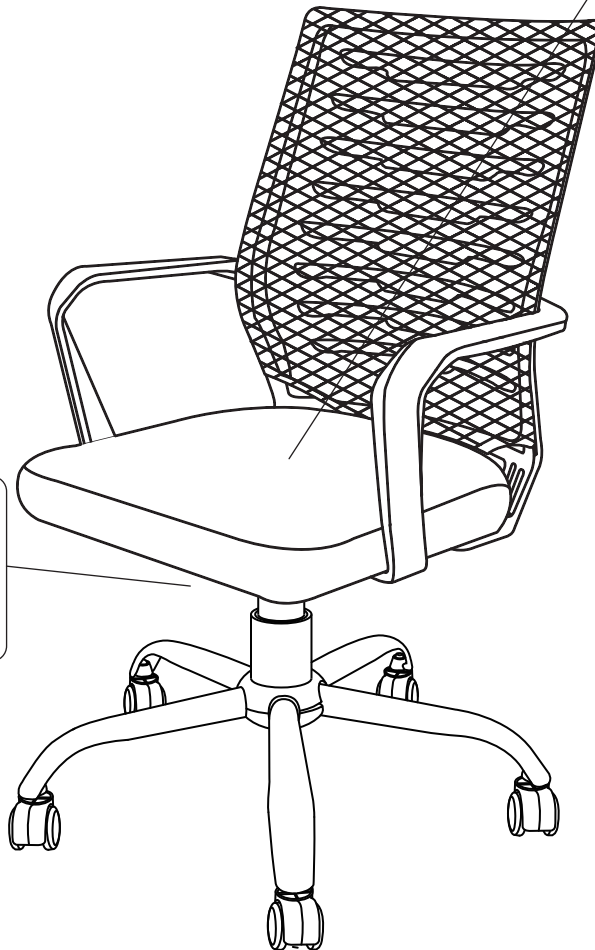

WARNING for California Residents:

This product can expose you to chemicals including Nickel (Metallic), which is known to the State of California to cause cancer. For more information, go to <https://www.p65warnings.ca.gov/>.

This chair is designed to hold the weight of one adult at a time and is for sitting and reclining purposes only. The armrests are not designed to be sat upon. Please do not use the chair as a stepstool, wheelchair or in any other unintended manner.

Failing to lock the adjustable actuator may lead to injuries. When adjusting the chair height upwards or downwards, gently push up on the lever. Do not over-extend or use excessive force when adjusting the chair angle.

ASSEMBLY INSTRUCTIONS

MODEL #

FGI-FC18011

Questions?

GIVE US A CALL: 1-888-980-5122
MON – FRI 8:30AM – 5:30PM (PST)

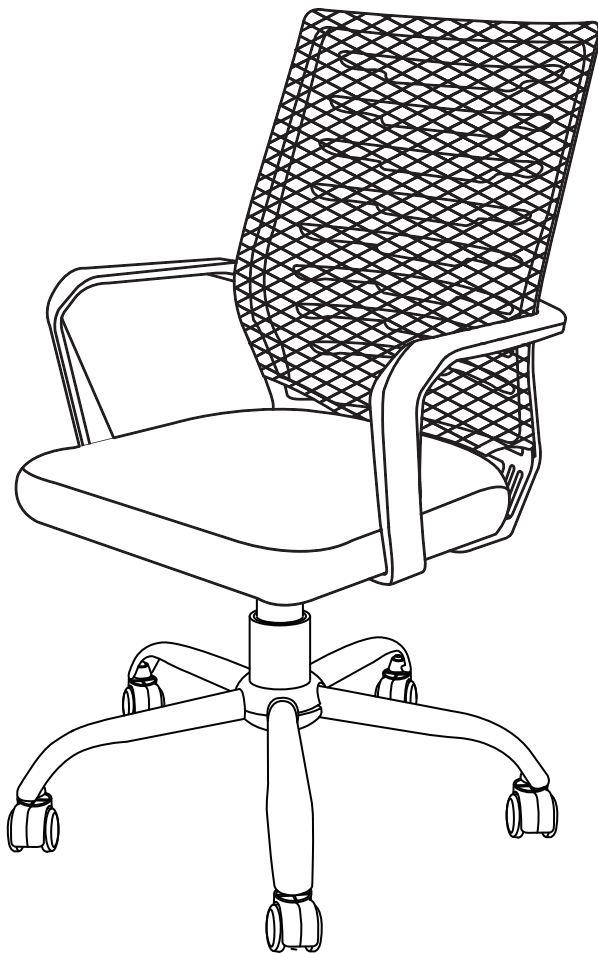

TOOLS REQUIRED



Hammer

(Not Included)



**Philips
Screwdriver**

(Not Included)



**2 - Persons
Recommended**

ASSEMBLY RATING



EASY → DIFFICULT

The Assembly Rating is a 5-point system showing the level of effort needed to assemble a specific product.



E-Commerce by Enitial Lab



FOA Intro

Thank you for your purchase!

We hope you enjoy this new addition to your home for many years to come.

Our commitment to providing quality products does not simply end when you purchase our product. We fully stand behind our products from start to finish. Our customer service department is available Monday – Friday 8:30 AM – 5:30 PM Pacific and can help with assembly questions as well as, if necessary, replacing damaged or missing parts. To help expedite our service, please have these assembly instructions readily available, along with your order receipt.



Consumer Hotline
Toll-Free 1-888-980-5122



Monday to Friday
8:30AM- 5:30PM (PST)



WEBSITE
www.foagroup.com



E-MAIL
cs.ec@foagroup.com



foagroup



FurnitureOfAmerica



CHECK BEFORE STARTING

Are you missing anything?

Double-check all parts, hardware and accessories listed on Page 6 are accounted for.

Check out our Quick Tips!

We recommend reviewing the pre-assembly handouts. Even experts need a refresher now and then!

Should we send any replacements?

Are there any irregularities or flaws in the parts? We can send replacements!

Prep Time!

Please review the assembly instructions and all diagrams prior to assembling. Arrange parts as recommended on Page 7 and group identical hardware together to make assembling easier.

PRE ASSEMBLY INTRODUCTION

We understand building ready-to-assemble furniture can be a challenging experience for some. To help avoid confusion, we have provided some helpful tips that may speed up the process.

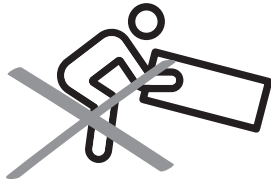

Teamwork

ALWAYS have at least two people to help with transporting and assembling the product to avoid potential injury and/or damage.

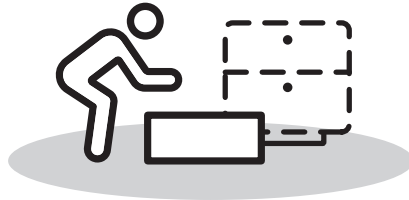
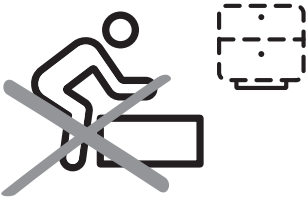

Suitable Location

Assembling near the area of the intended location is highly recommended.



Sufficient Space

Make sure you have enough space to move around during the assembly.



Avoid Scratches

Use cardboard, blankets or a carpeted area while assembling furniture to prevent scratches.

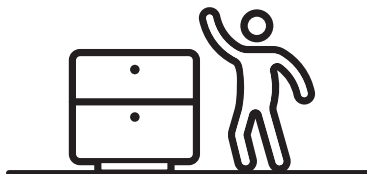
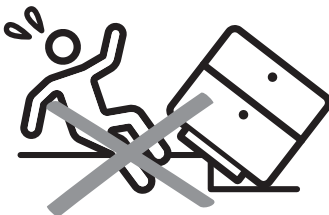

Flat Surface

Make sure the furniture rests on a flat and level surface with each leg evenly touching the floor.

OFFICE CHAIR

FGI-FC18011

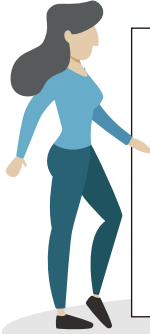

- Please keep instructions for future reference.
- Check the quantity and irregularity of parts and hardware before you start.

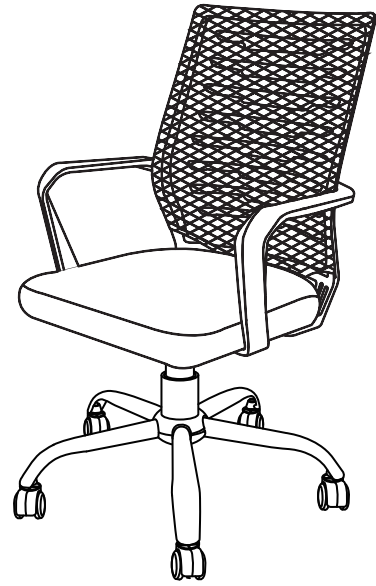

PARTS

A 1PC

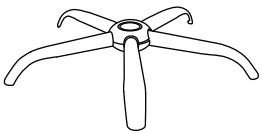

B 1PC



C 1PC

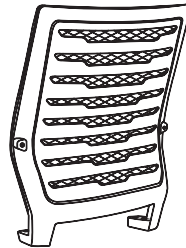

D 2PCS

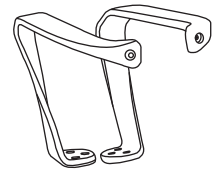

HARDWARE

- ① 2PCS ② 6PCS ③ 4PCS



ACCESSORIES

- A1 5PCS A2 1PC A3 1PC A4 1PC



ASSEMBLY INSTRUCTIONS

1

Part **A** x1PC

Accessory **A1** x 5 PCS

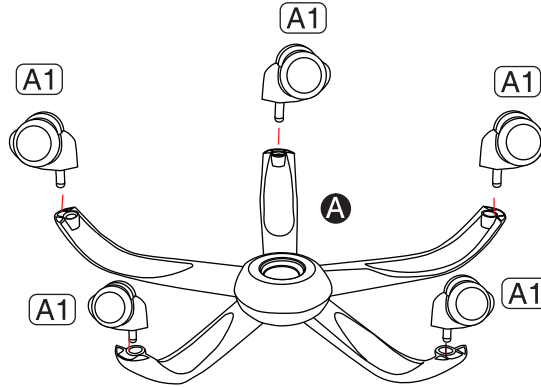

Attach casters (#A1) to five star base (#A).

2

Accessory **A2** x 1 PC

Accessory **A3** x 1 PC

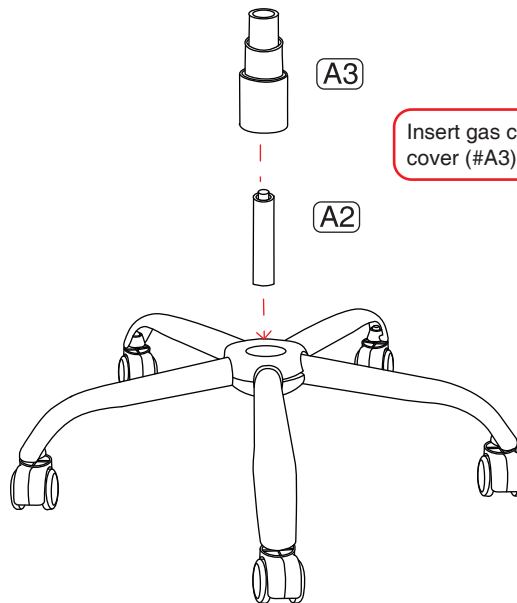

Insert gas cylinder (#A2), then cylinder cover (#A3) to five star base.

ASSEMBLY INSTRUCTIONS

3

Part **B** x1PC

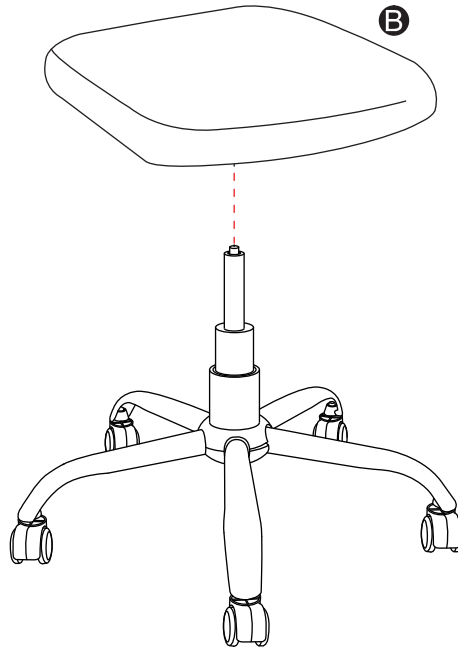

Attach seat (#B) to gas cylinder.

4

Part **C** x1PC

Hardware **3** x 4 PCS

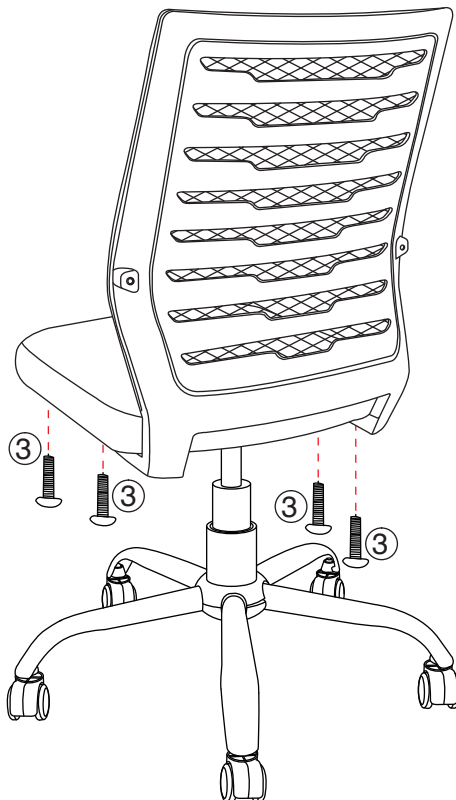

C Align backrest (#C) holes to the bottom of the seat, then secure by using bolts (#3).

ASSEMBLY INSTRUCTIONS

5

Part **D** x1PC

Hardware **①** x 1 PC

Hardware **②** x 3 PCS

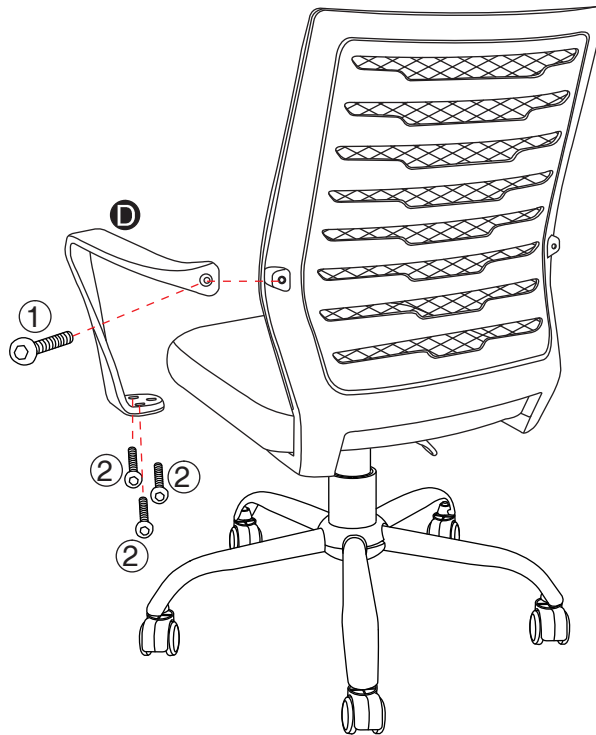

Align armrests (#D) to chair, then secure by using bolts (#1,2).

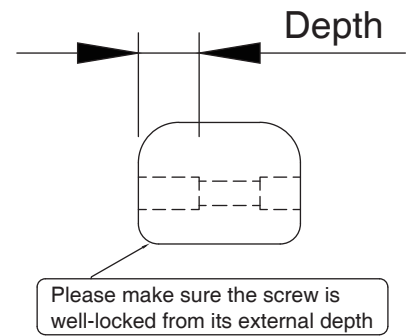

6

Part **D** x1PC

Hardware **①** x 1 PC

Hardware **②** x 3 PCS

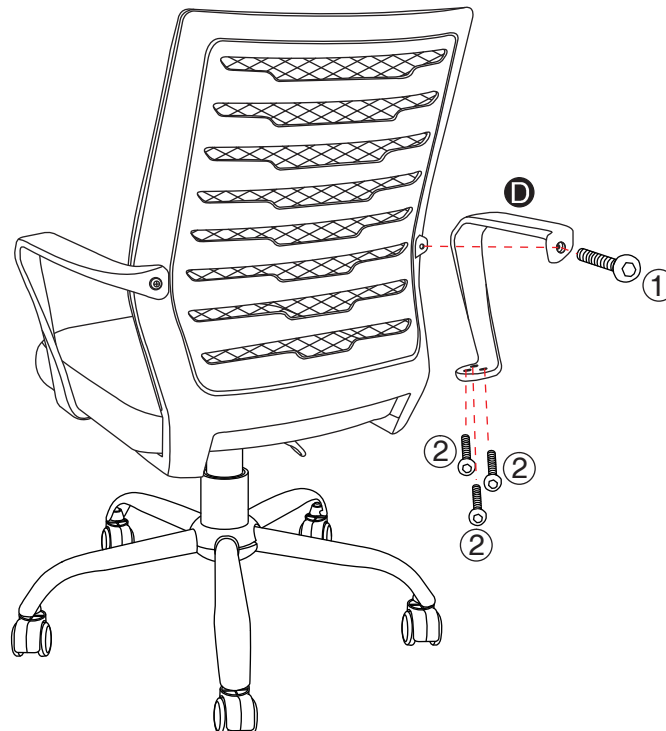

ASSEMBLY INSTRUCTIONS

7

ASSEMBLY COMPLETED



Please ensure the furniture rests on an even and flat surface. If the product wobbles or feels loose, double-check all bolts and/or screws are properly tightened and secured.



Keep this handy!

Please retain this instruction manual and any order-related information for future reference.

