



432HS, 432SH, 432W
Sereno[™] Hand Shower/Showerhead/Hand Shower Wand
Operation & Maintenance Manual

Model Numbers	Specifications
<input type="checkbox"/> 432HS <i>Hand Shower Assembly</i> <input type="checkbox"/> 432SH <i>Showerhead</i> <input type="checkbox"/> 432W <i>Hand Shower Wand</i>	<p>Hand shower assembly, showerhead and hand shower wand include standard 2.5 gpm (9.5 L/min) flow restrictor. Components are made from metal and nonmetallic materials plated in standard polished chrome finish.</p>
Modifications	Warranty
<input type="checkbox"/> -1.5  <i>1.5 gpm (5.7 L/min) flow restrictor</i> <input type="checkbox"/> -2.0  <i>2.0 gpm (7.6 L/min) flow restrictor</i> <input type="checkbox"/> -STN <i>Satin nickel finish</i>	<p>Limited Lifetime - to the original end purchaser in consumer installations. 5 Years - for commercial installations.</p> <p>Refer to www.symmons.com/warranty for complete warranty information.</p>

Note: Append appropriate -suffix to model number.

Dimensions

432HS

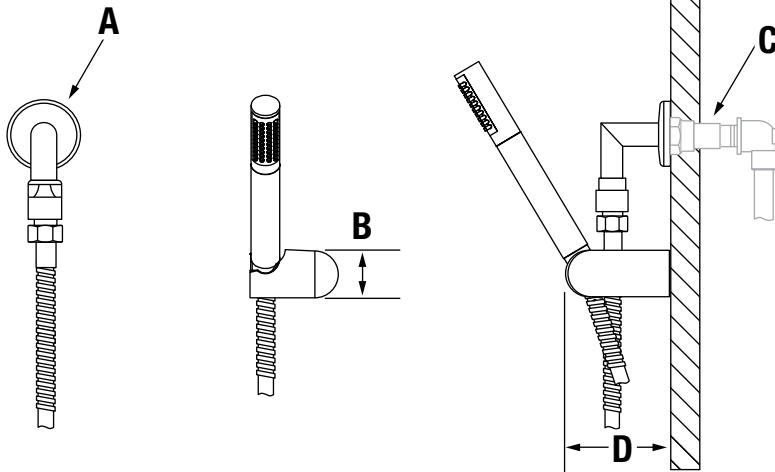

Measurements	
A	Ø 2 1/4", 57 mm
B	Ø 1 1/2", 38 mm
C	Female 1/2" IPS thread must be recessed 7/8" from finished wall
D	3 1/4", 83 mm
E	6", 152 mm
F	7 5/16", 186 mm
G	7 1/2", 191 mm
H	Ø 1", 25 mm

432SH

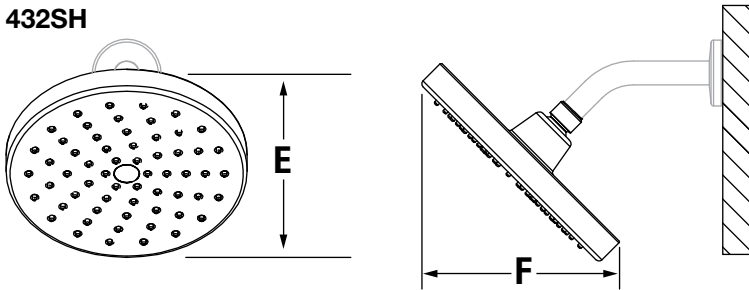

432W

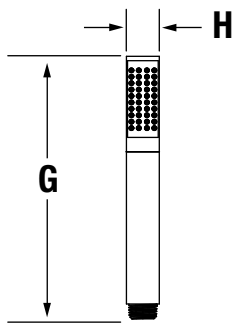

Note: Dimensions are subject to change without notice.

Parts Breakdown

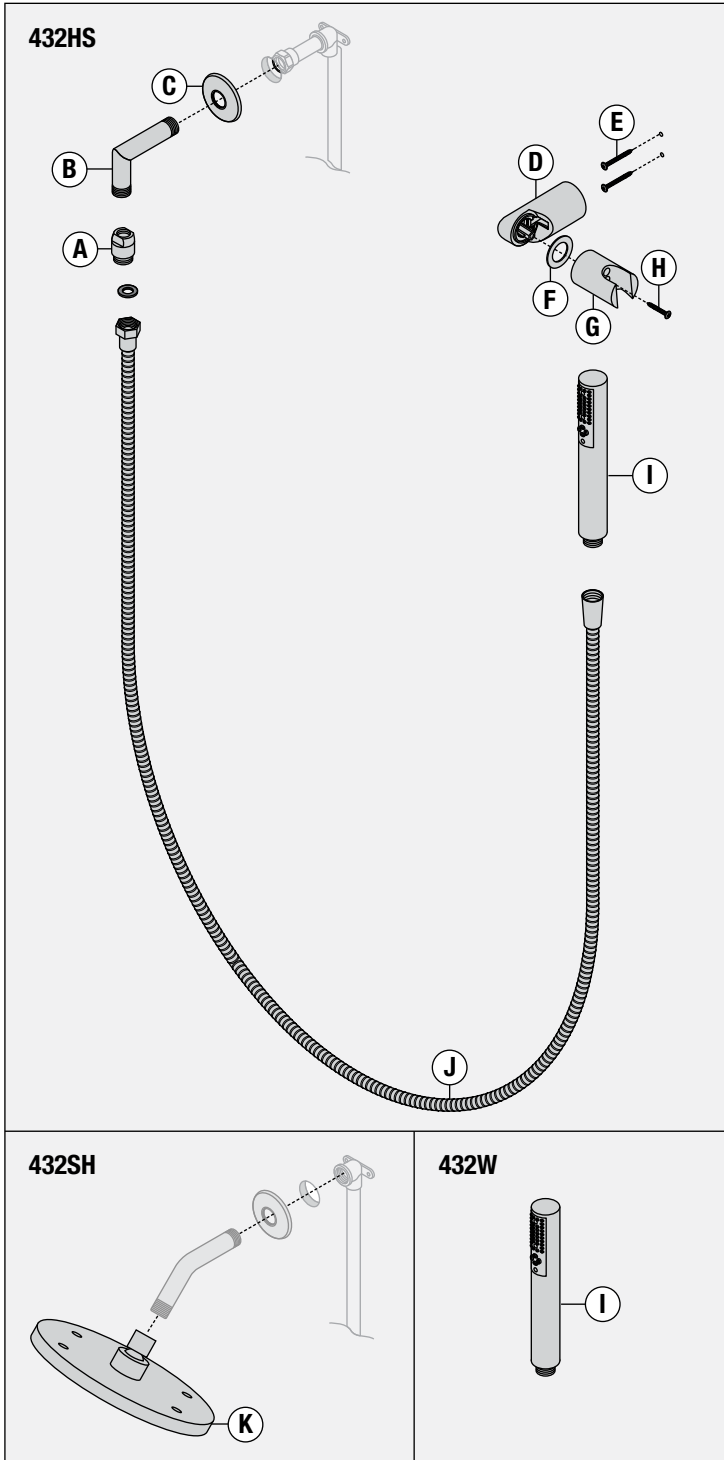



Replacement Parts

Item	Description	Part Number
A	Vacuum Breaker	EF-104
J	60" Hose	
B	Wall Elbow	T-444-KIT
C	Flange	
D	Cradle Mount	
E	Cradle Mounting Screws	T-545
F	Washer	
G	Cradle Arm	
H	Set Screw	
I	Hand Shower	432W
K	Showerhead	432SH

Notes:

- 1) Append -STN to part number for satin nickel finish.
- 2) Append -1.5 or -2.0 to showerhead or hand shower for low flow.

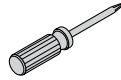
Required for Installation

Adjustable wrench	
Phillips head screwdriver	
Plumber tape	

Installation

1) Install wall elbow (B) and flange (C) to recessed pipe fitting. Turn elbow clockwise to tighten (432HS only).

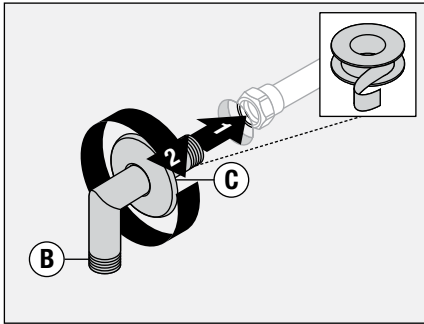

2) Press tab to remove mounting plate (D2) from cradle mount cover (D1).

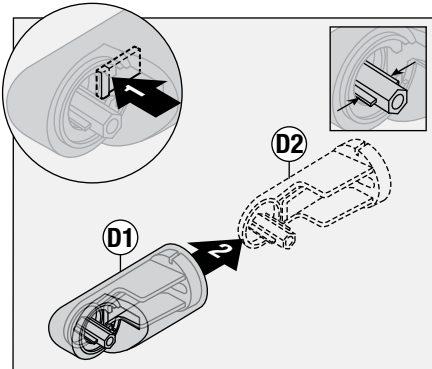

Note: Mounting plate (D2) center tabs must be horizontal for removal.

3) Place mounting plate (D2) in position, mark and drill 1/8" pilot holes into stud.

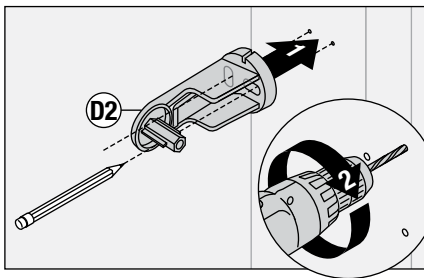

Option: Place mounting plate (D2) in position, mark and drill 3/16" holes into wall. Install anchors.

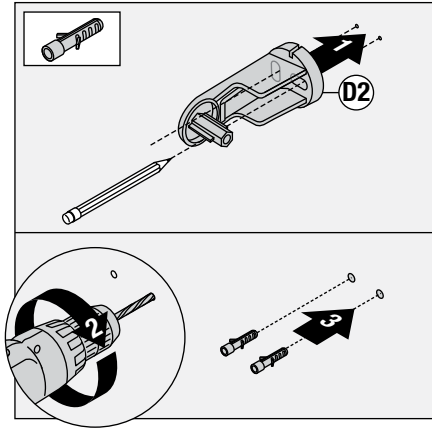

4) Install mounting plate (D2). Secure with two screws (E). Replace cradle mount cover (D1).

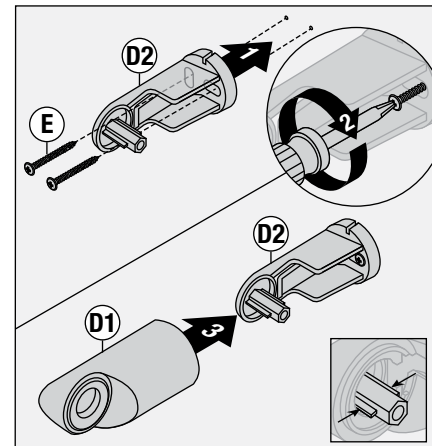

Note: Mounting plate (D2) center tabs must be horizontal for installation.

5) Attach cradle arm (G) and washer (F) to cradle mount (D) cover. Secure with set screw (H).

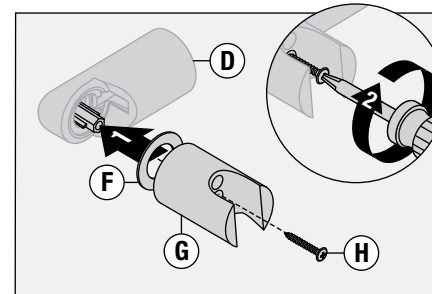

6) Install showerhead (K) to shower arm turning clockwise to tighten (432SH head only).

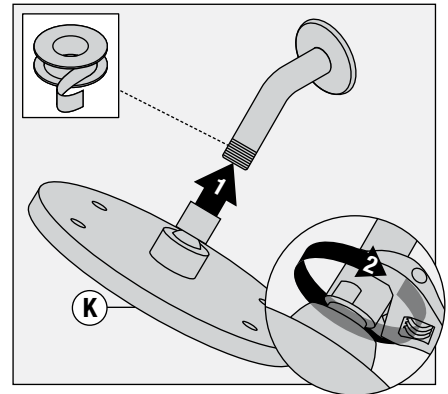

7) Attach large end of hand shower hose (J) to hand shower (I). Attach small end of hand shower hose (J) and gasket to in-line vacuum breaker (A). Connect in-line vacuum breaker to wall elbow (B). Turn clockwise to tighten.

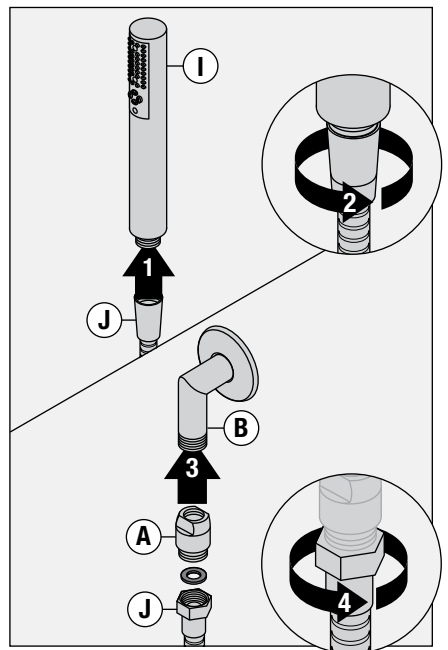

Care and Cleaning

- 1) Clean finished trim area with a soft cloth using mild soap and water or a non-abrasive cleaner and then quickly rinse with water.

Troubleshooting Chart

Problem	Cause	Solution
Finish is spotting.	Elements in water supply may cause water staining on finish.	Clean finished trim area with a soft cloth using mild soap and water or a non-abrasive cleaner and then quickly rinse with water.