

CATSKILL

C R A F T S M E N , I N C .

Assembly Instructions Model 51537

Deluxe Microwave Cart



GENERAL:

1. You have purchased model 51537.
2. Should you need assistance or need to replace a damaged or missing part simply give us a call M-F at 607-652-7321 from 7:30 am - 4:30 pm EST and we'll send you the prepaid part via UPS usually that same day! You may also email us info@catskillcraftsmen.com.
3. Read the assembly instructions and the enclosed brochure before beginning assembly. Assembly is easy if you read and follow the instructions step by step. See our website for assembly tips and videos.
4. The only tools needed are a hammer, a small and a medium Phillips head screwdriver and a medium flat blade screwdriver. A pencil is also needed. A power screwdriver will speed assembly, but is not required. Place a few drops of vegetable oil on the threads of wood screws before screwing into the solid hardwood parts.
5. Glides are sometimes pre-packed with screws. These are not used.

CABINET PARTS 51537

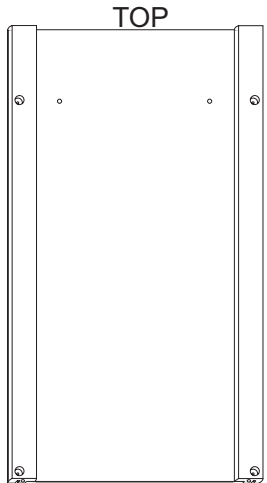

Handle Side Panel (1)
P/N: SP HDL - 51537

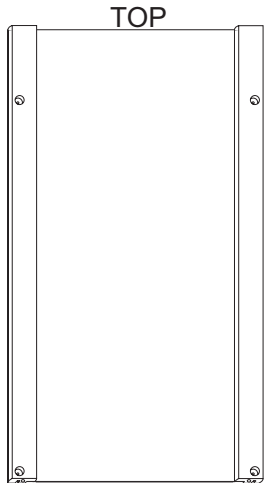

Plain Side Panel (1)
P/N: SP PL - 51537

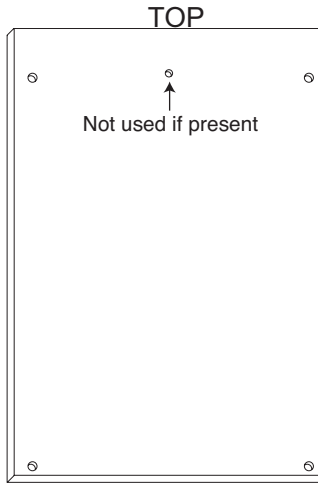

Back Panel (1)
P/N: BP - 51537

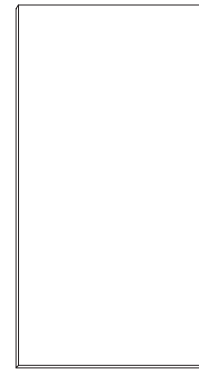

Drawer Bottom (1)
P/N: DBOT - 51537

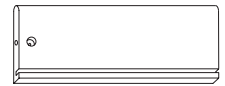

Drawer Side Left (1)
P/N: DS - 51537/L



Drawer Side Right (1)
P/N: DS - 51537/R

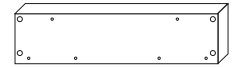

Glide Support Sticks (2)
P/N: GLD SUP - 51537



Cabinet Top (1)
P/N: TT - 51537

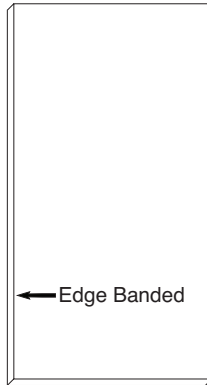

Middle Shelf (1)
P/N: MS - 51537

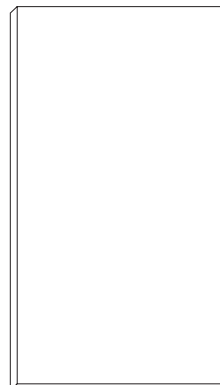

Bottom Shelf (1)
P/N: BS - 51537

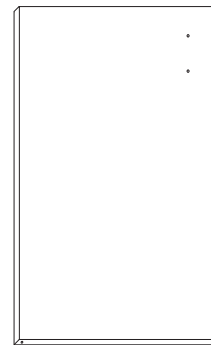

Left Door (1)
P/N: DOR - 51537L

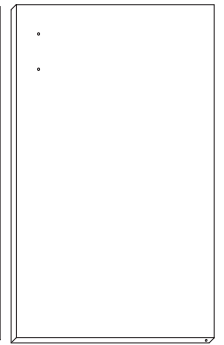

Right Door (1)
P/N: DOR - 51537R

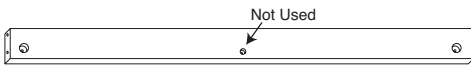

Bottom Brace (1)
P/N: BB - 51537

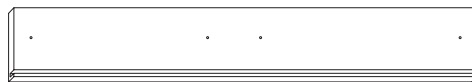

Drawer Front (1)
P/N: DF - 51537

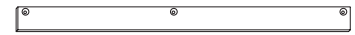

Door Spacer (1)
P/N: DORS - 51537



Drawer Back (1)
P/N: DBK - 51537

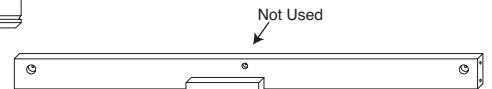

Top Brace (1)
P/N: TOP BRACE - 51537

RACK PARTS



Rack Top (1)
P/N: RKTP - 51537

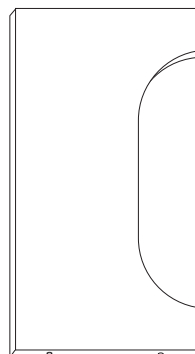

Rack Side Panels (2)
P/N: RKSP - 51537

HARDWARE 51537



1 3/4" Phillips Flat Head Bolt (8)

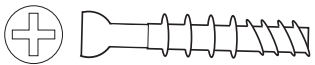

Cam Posts (2)
(Used to attach Drawer Front)

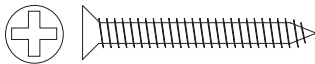

1 1/4" Phillips Flat Head #8 Screw (20)
(Use the 8 Bronze screws to assemble the rack)

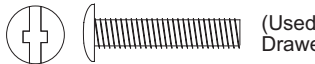

7/8" Truss Head Machine Screw (6)
(Used to attach Drawer Handles)

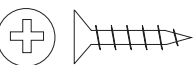

5/8" Phillips Head #5 Screw (4)
(used to attach drawer glides)



5/8" Phillips Flat Head #7 Screw (12)
(Used to attach cabinet glides & "L" Brackets)

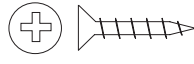

5/8" Phillips Flat Head #8 Screw (3)
(Used to attach door spacer)

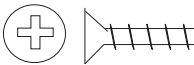

1" Phillips Flat Head #8 Screw (2)
(Used to attach Towel Bar)



(Brace Pin)
3/4" Long 3/16" DIA. Steel Pin (4)

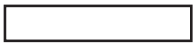

(Shelf Pin)
1" Long 3/16" DIA. Steel Pin (8)

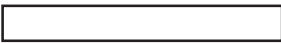

(Door Pin)
1 1/2" Long 3/16" DIA. Steel Pin (4)

MAGNET PACK



Magnet (1)

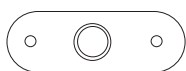

Magnet Plate (1)



5/8" Pan Head Screw (2)



1/2" Phillips Flat Head #4 Screw (1)



3/16" Flat Washer (4)



10-24 Hex Nut (8)

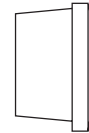

5/8 Wooden Disk (8)

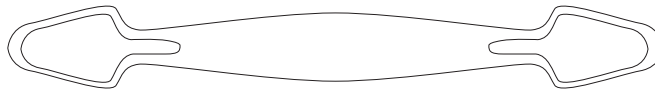

Nickel Handle (3)



Towel Bar Post (2)

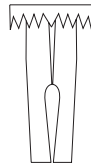

Caster Socket (4)

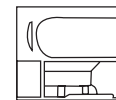

Cam (2)

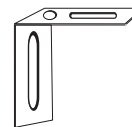

"L" Bracket (4)

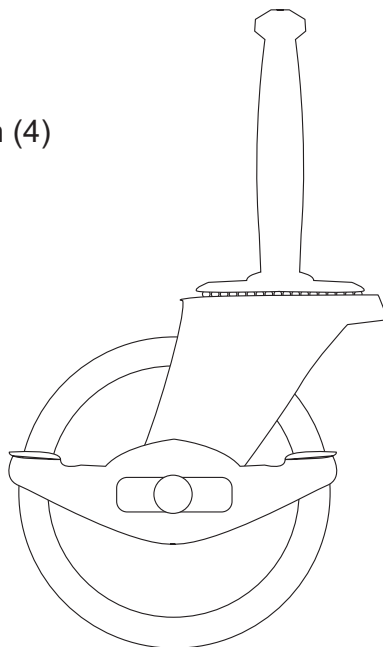

Locking Wheel Caster (2)

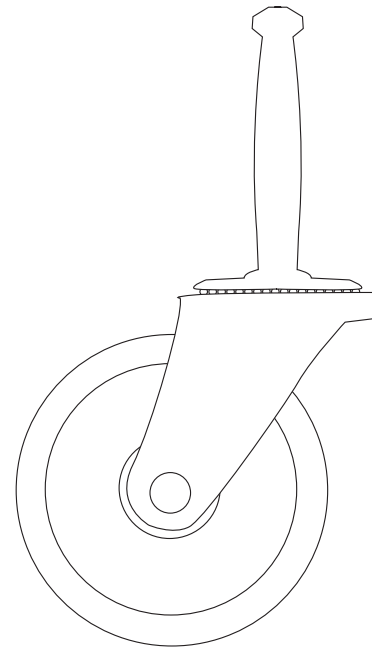

Non-Locking Wheel Caster (2)

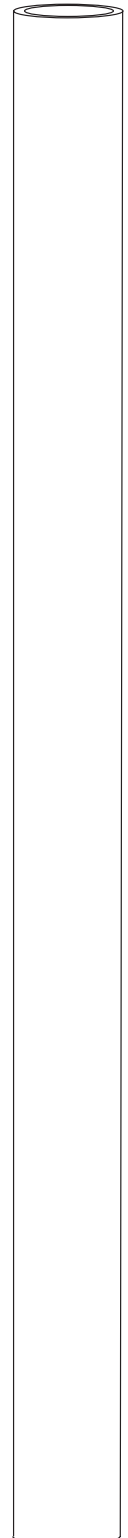

Polished Nickel Towel Bar (1)

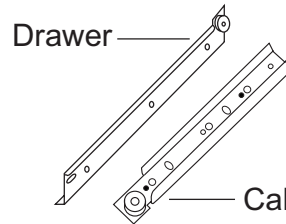

Drawer

Cabinet

14" Drawer Glide (1 Set)

STEP 1

1. Attach the Rack Top to the top ends of the Side Panels (universal: same left/right & top/bottom) using 1 1/4" #8 wood screws. **MAKE SURE YOU HAVE THE RACK TOP!** The only difference between the Rack Top and the Cabinet Top is that the Cabinet Top has 4 small pilot holes on the bottom side plus the 4 through holes; whereas, the Rack Top only has the 4 through holes.

NOTE: On the Rack Top the countersunk (reamed out) through holes face up and the countersunk holes/pilot holes on the Cabinet Top face down. The countersunk holes allow the screw heads to be flush with the wood surface when tightened down.

2. Turn this assembly upside down so that the Rack Top is on a smooth flat surface. Attach the Cabinet Top with four 1 1/4" #8 wood screws. With the unit upside down at this point, the 4 pilot holes should be up. See illustration 1B.

3. Leave this assembly UPSIDE DOWN and go to STEP 2.

NOTE: The cart cabinet will be constructed upside down using the bottom of the Cart Top as the base.

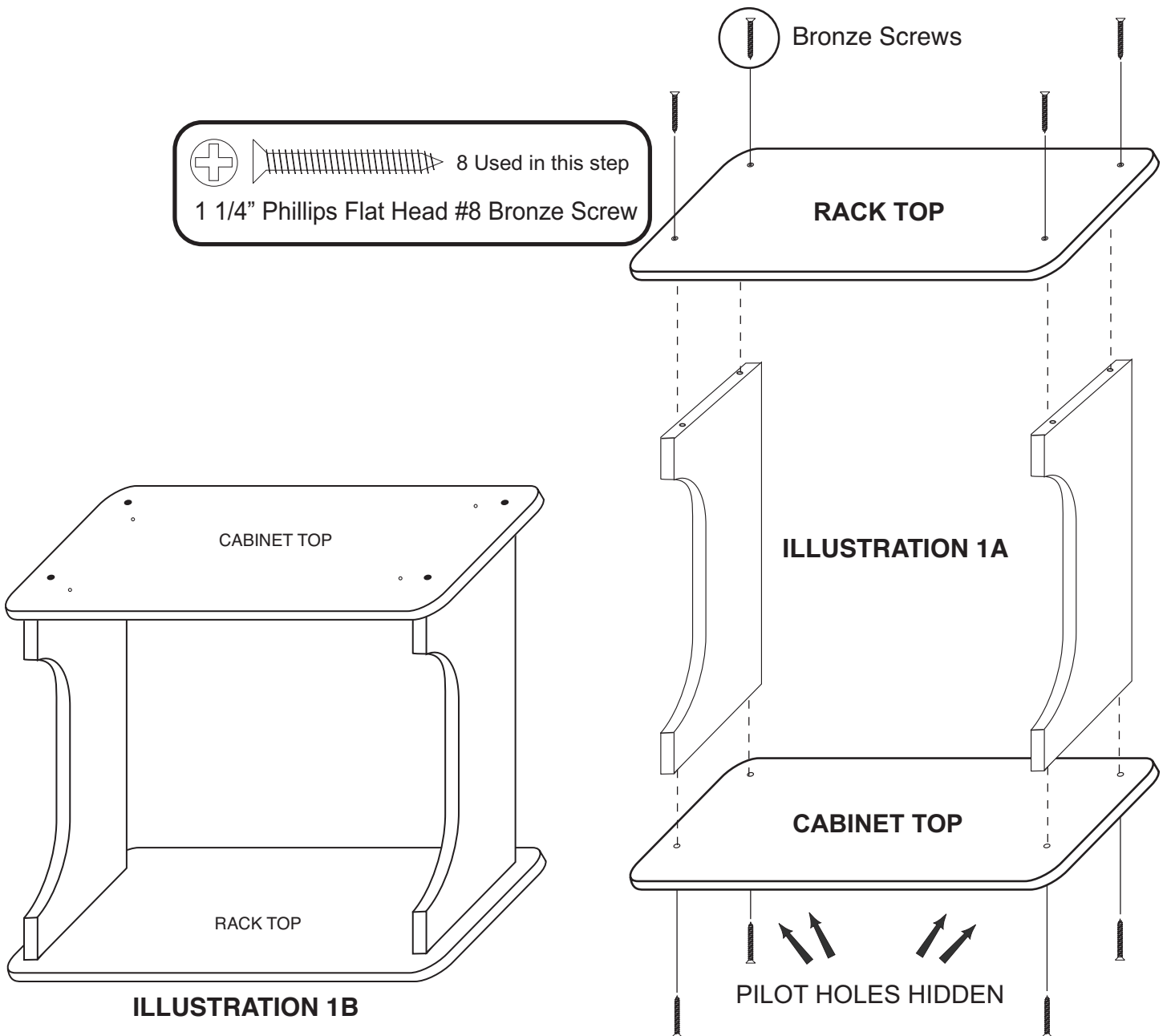

STEP 2

Glide Support Assembly

Decide at this point if you want the handle/towel bar on the right or the left side of the cabinet as side panels are interchangeable. At this point the metal glides will determine left side/right side once installed.

The "L" brackets are attached to the Glide Support using the large slot in the "L" bracket. The Hole will be used to attach the table top.

Top of "L" Bracket should be even with the top of the glide support

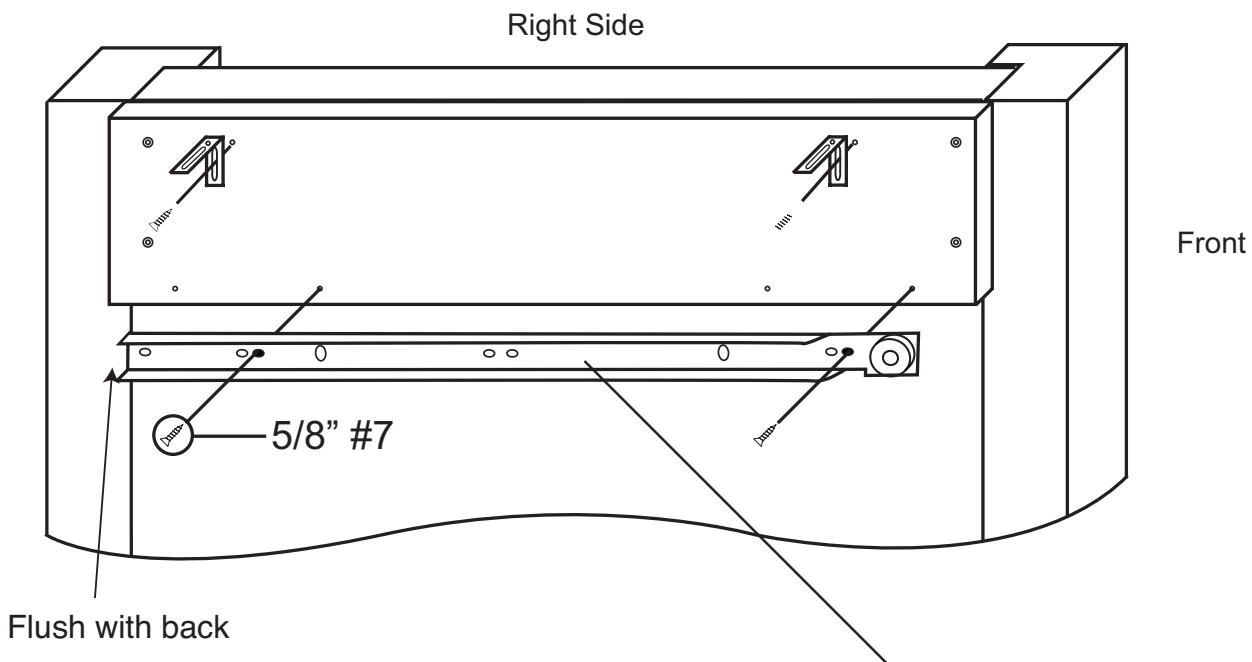
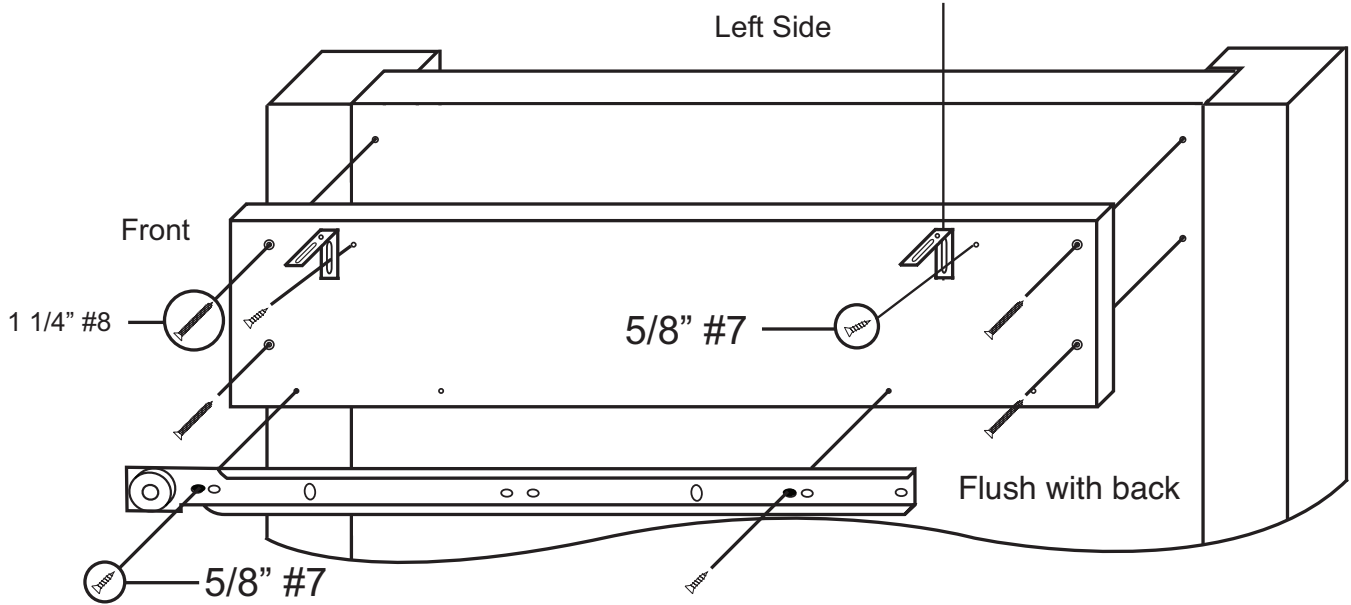

Note: Glide holes sometimes change, just make sure the cabinet glides are flush with the back of the glide supports & pilot holes will line up - only 2 holes are used!

The glides look almost alike; however, they are stamped CR for cabinet right and CL for cabinet left.

STEP 3

A. Lay back panel flat on a smooth surface with holes up.

B. We placed the handle/towel bar on the right for these instructions.

C. Attach side panels with 1 3/4" bolts and hex nuts. After inserting bolt(s) through the holes in the side panels and through the holes in the long edges of the back panel, place a hex nut on the tip of your finger, align nut with bolt and tighten.

D. Look ahead to step 3 which shows side panels attached to back panel.

E. Attach towel bar with 1" Phillips Flat head screws/washer. Use a washer to prevent the screw from pulling through the side panel.



NOTE: Back panel is flush with bottom of side panels.

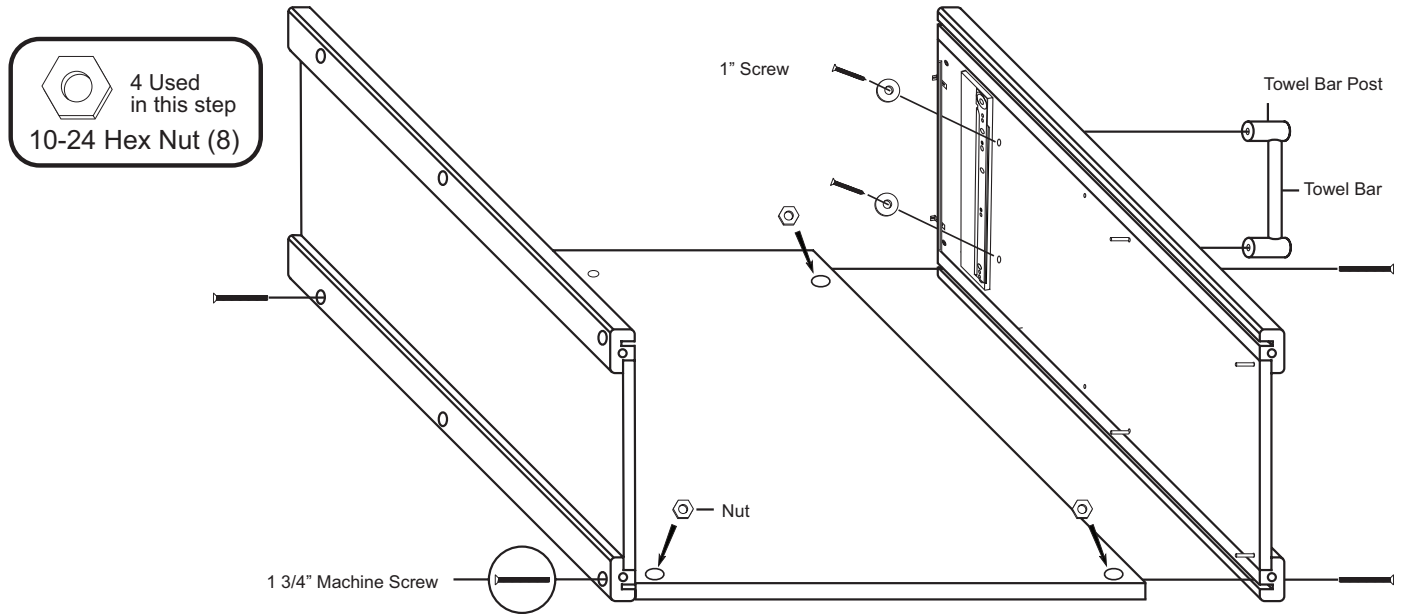

STEP 4

A. Turn the side/back assembly (from step 2) upside down (invert) on top of the inverted table top.

B. Align the "L" brackets with the 4 inside pilot holes in the table top and secure with 5/8" #7 screws.

C. Tap two 1" pins into each side panel. These pins will hold the bottom shelf.

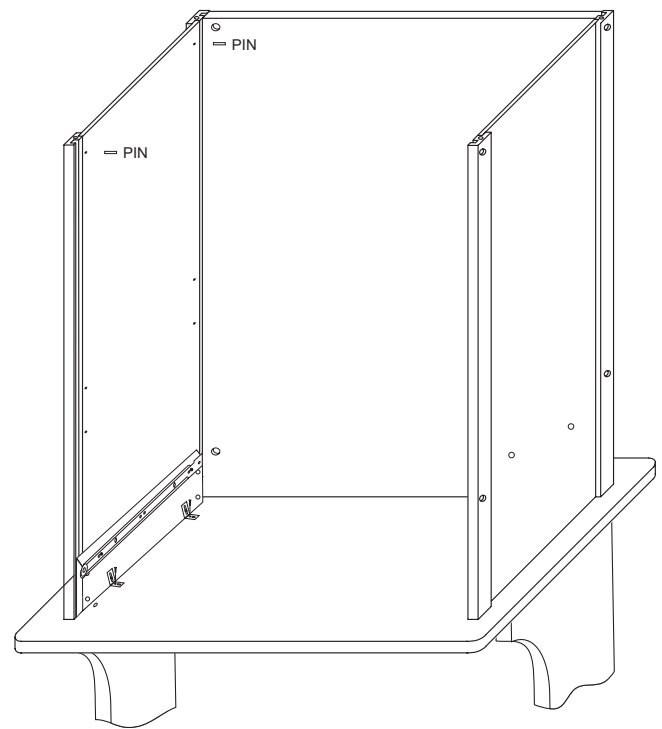
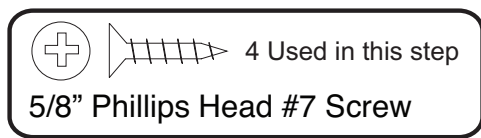
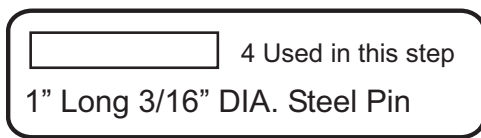

STEP 5

A. Attach the drawer back to the drawer sides with four 1 1/4" #8 screws. Make sure parts are aligned as in illustration 6A.

B. Insert drawer bottom into the slots in the drawer sides, best side to inside of drawer. Slide down until seated in the slot in the drawer back. See illustration 6B.

C. Screw the cam posts into the two outside holes on the inside face of the drawer front until seated. Only 3/8" of the post goes into the wood, leaving the 4 larger guide rings/head exposed. See illustration 6C. Visit us at www.catskillcraftsmen.com to view our cam video.

D. Insert the posts into holes in the drawer sides until seated against the front end of the drawer sides. Insert cams so that slot in the cam fits over the post and turn with Phillips screwdriver until seated. Don't over-torque! See illustration 6D. See our video online at www.catskillcraftsmen.com

E. Attach drawer handle with two 7/8" Truss Head screws each. (no illustration).

F. Attach drawer glides to drawer sides using 5/8" #5 screws. See illustration 6E

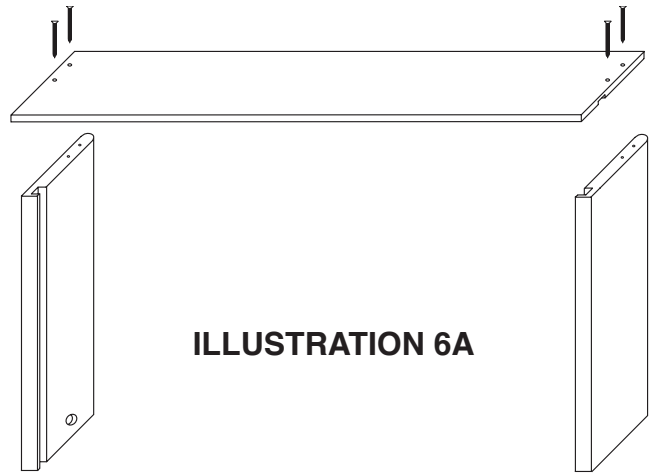

ILLUSTRATION 6A

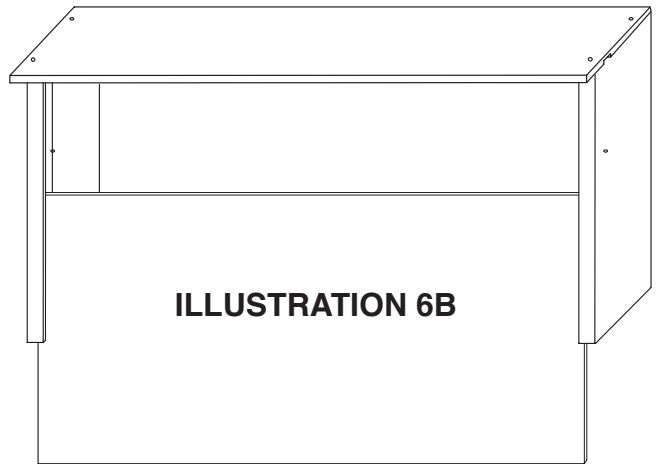

ILLUSTRATION 6B

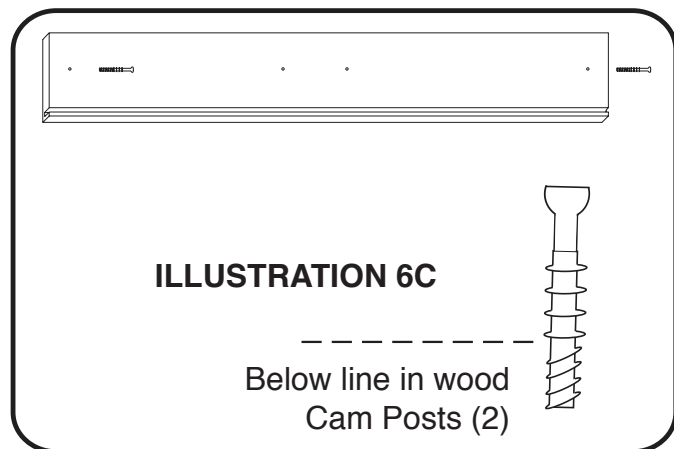

ILLUSTRATION 6C

Below line in wood
Cam Posts (2)

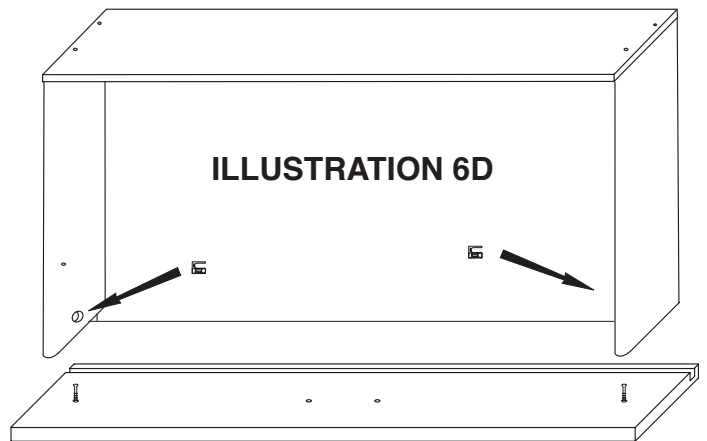

ILLUSTRATION 6D

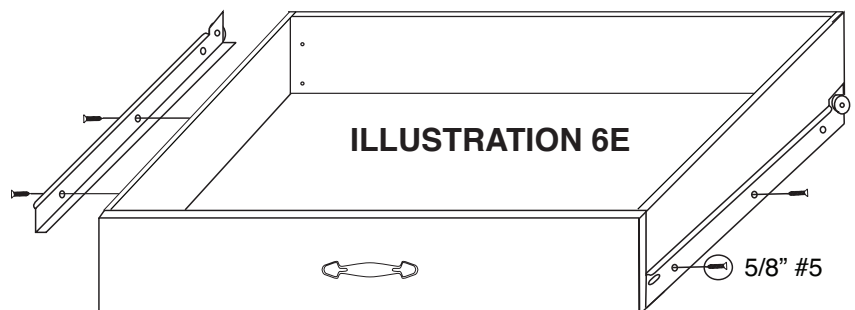
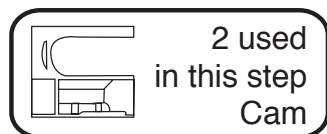
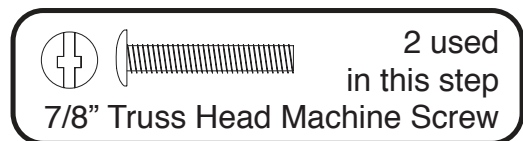
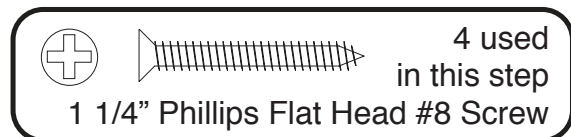

ILLUSTRATION 6E

STEP 6

Door Assembly

A. Tap/insert ONE 1 1/2" pin into each end of both doors. DON'T OVERDRIVE PINS! Pins should stick up about 1/2" when seated.

B. Attach the door spacer to the left door with 5/8" #8 screws. The spacer has a space at the top to allow magnet clearance and is almost flush with the bottom of the door. Countersunk holes out.

C. Attach the magnet plate (may be stuck to magnet!) with the 1/2" #4 screw to the top of the right door. Bumps go toward the wood.

D. Attach door handles with 7/8" truss head machine screws.

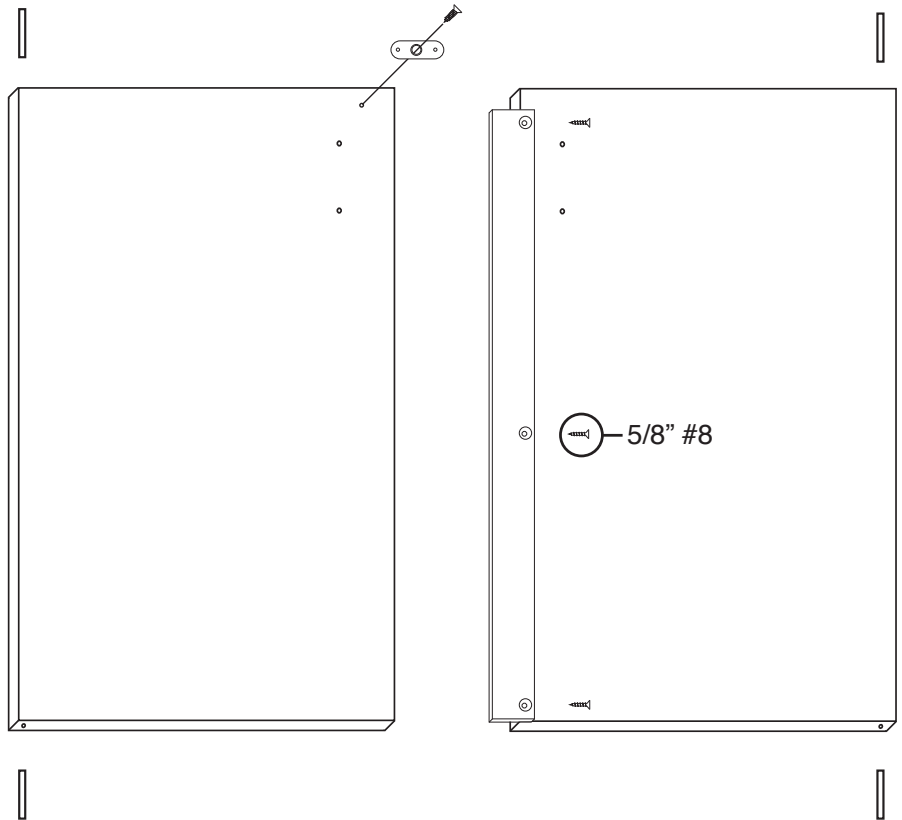

STEP 7

Brace Prep

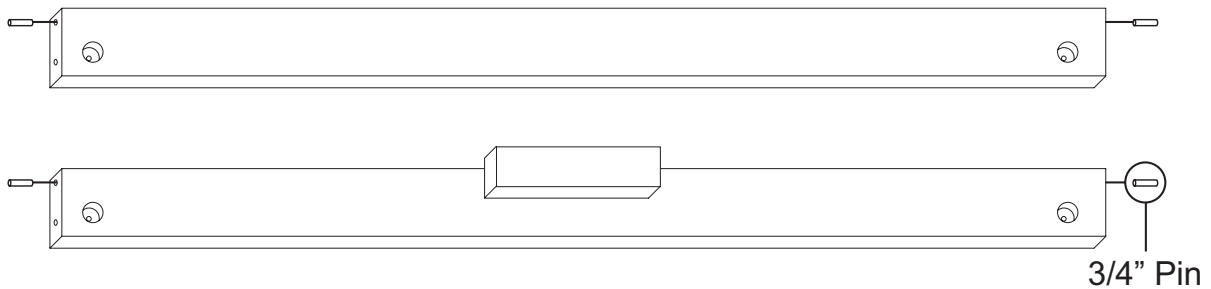

Install 3/4" pins in brace ends

STEP 8

A. Take the top front brace (identical to bottom front brace) holes in bottom long edge up, insert the pins into the slots on the inside of the front legs and slide brace down until the holes in the brace ends align with the holes in the front legs. Secure brace with 1 3/4" bolts/hex nuts.

B. Take the middle front brace with magnet block and slide brace into place making sure magnet block and holes for door pins are up as illustrated. Secure with 1 3/4" bolts/hex nuts.

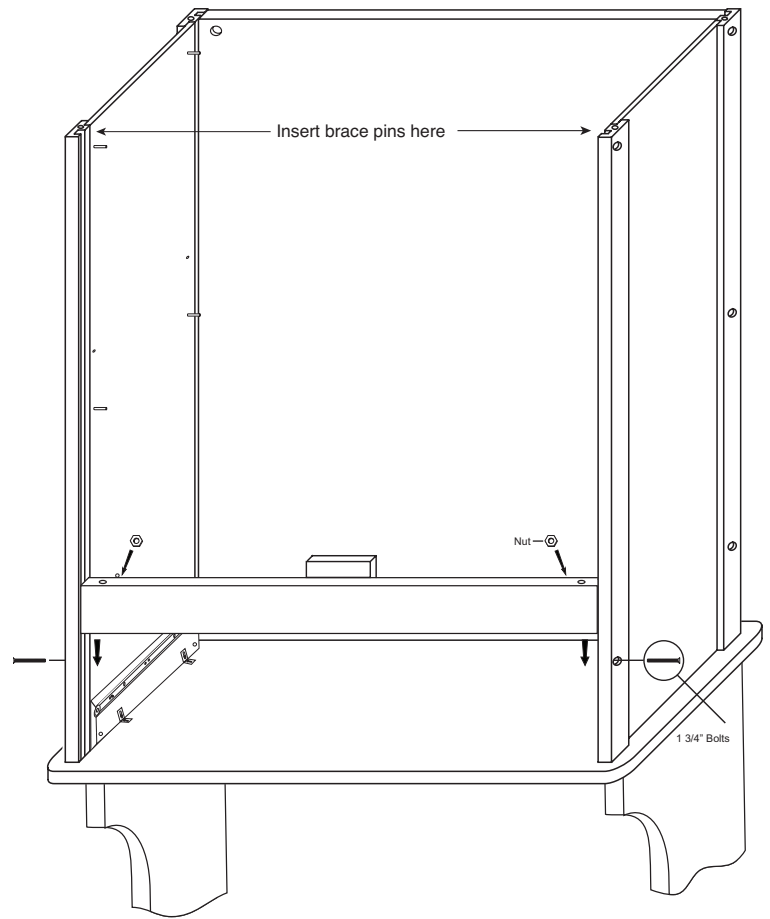

ILLUSTRATION 8

STEP 9

A. Insert the pins in the door tops into the holes in the middle front brace as in Illustration 7. Place a washer over the pins in the door bottoms.

B. Take the bottom front brace, insert brace as in step 7, making sure the pins in the doors align with the holes in the brace as in Illustration 8. Secure with 1 3/4" bolts/hex nuts.

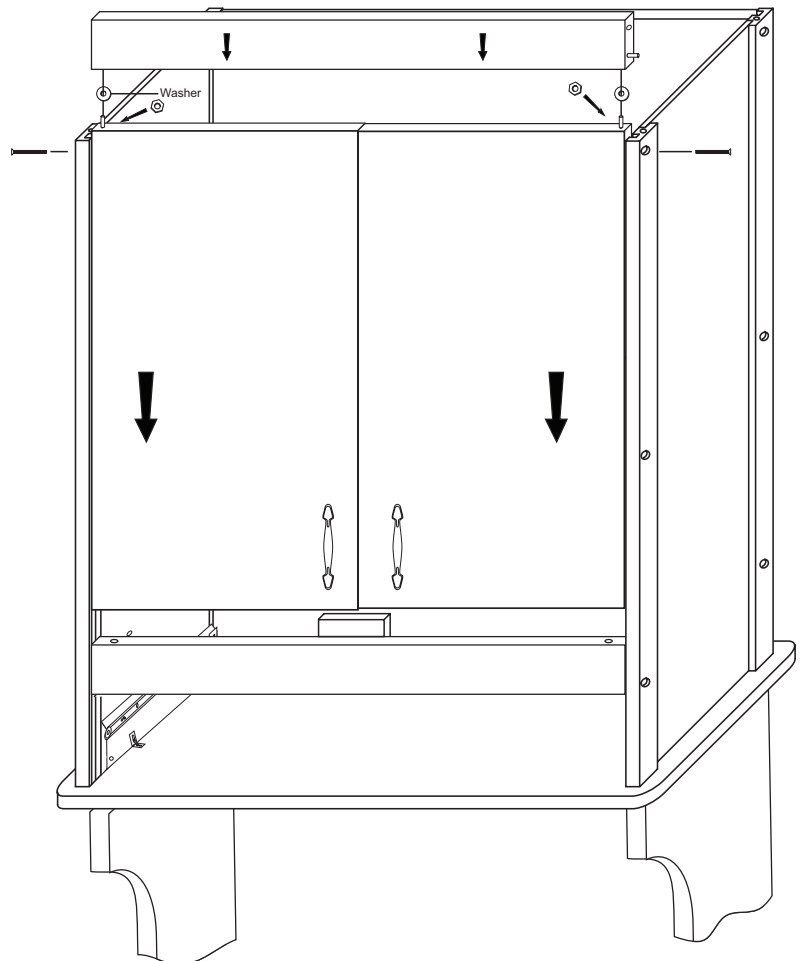

ILLUSTRATION 9

STEP 10

Install Magnet

- Stick magnet to magnet plate on right door.
- With left door open, close the right door. The magnet should be positioned over the wooden block on the bottom of the top front brace. Hold the magnet in place with your thumb, and open the right door. The magnet will be in the correct position on the block. Mark your holes with a pencil.
- Secure magnet with the two pan head screws in the magnet packet. Center screws in the slots in the magnet. This will allow adjustment later, if needed.

NOTE: No pilot holes in block, as softwood!

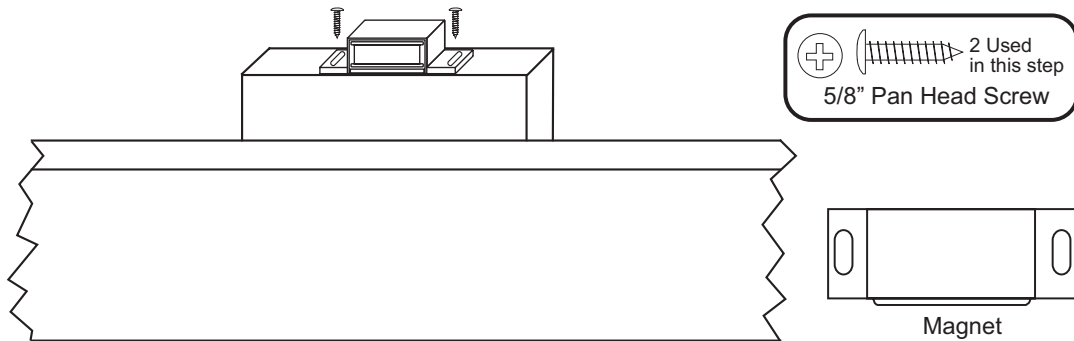

STEP 11

Install Casters

- Tap in caster sockets with a hammer until teeth are in the wood. Don't pound flat or wheels won't enter. Locking casters usually go on front - seat with sharp downward stroke with hammer hitting the metal wheel frame.

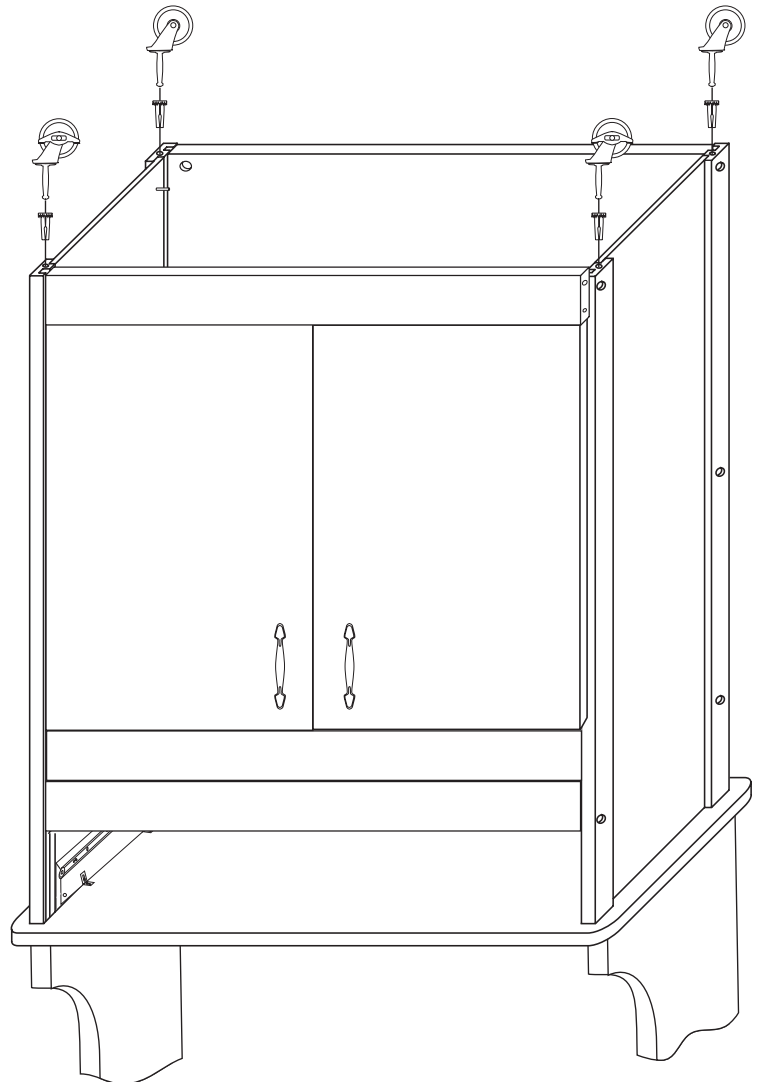

STEP 12

- A. Upright unit and insert drawer.
- B. Insert pins for the middle shelf.
- C. Place middle shelf on pins.
- D. Place the back long edge of the bottom shelf on the back pins. Lower front of shelf. Close doors and shelf will drop into place.
- E. Tap in the 12 wood disks into the side panels after making sure drawer and doors open/close easily. Tighten all bolts.

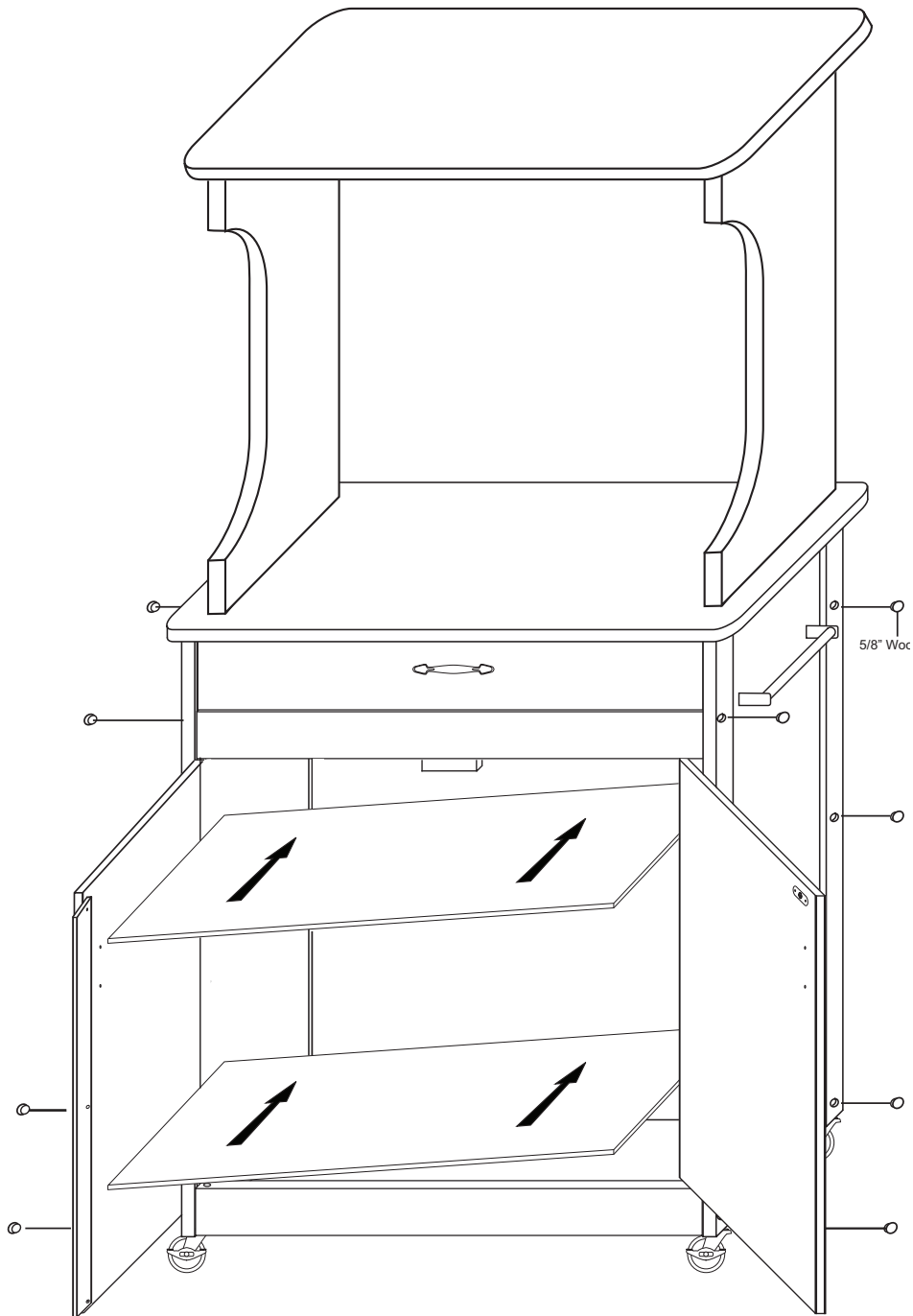
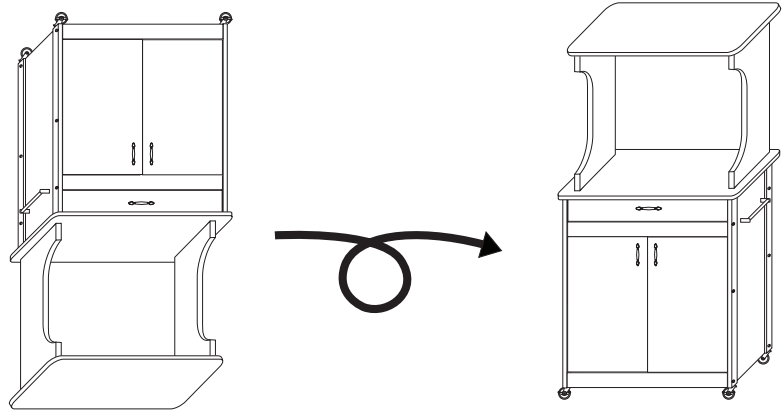



For continued beauty and long life of your Catskill Craftsmen cart, we recommend Catskill Craftsmen's Butcher Block Oil.

Our Butcher Block Oil is available directly from Catskill Craftsmen's factory. For one eight ounce (8 fl. oz.) bottle, which is sufficient for two applications, simply send \$6.95 along with the completed coupon to the address below. Visit us online at www.catskillcraftsmen.com to browse our assortment of butcher block care products. Visa and Mastercard are accepted online .



Catskill Craftsmen, Inc.
15 West End Ave.
Stamford, NY 12167-1296



BUTCHER BLOCK OIL COUPON

Please send me _____ # of bottle(s) of the Catskill Craftsmen Butcher Block Oil at \$6.95 per bottle. My check or money order is enclosed for a total of \$_____.

Item code: 51537

Name _____

Address _____

City _____

State _____ Zip _____

Please make checks payable to Catskill Craftsmen Inc. 15 West End Ave., Stamford, NY 12167-1296