

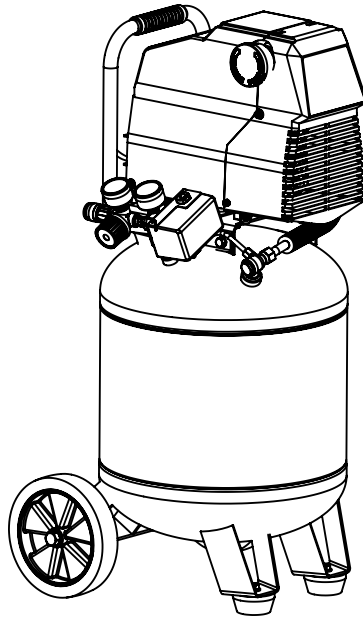

10-GALLON AIR COMPRESSOR



Model # 2289
bit.ly/wenvideo

IMPORTANT:

Your new tool has been engineered and manufactured to WEN's highest standards for dependability, ease of operation, and operator safety. When properly cared for, this product will supply you years of rugged, trouble-free performance. Pay close attention to the rules for safe operation, warnings, and cautions. If you use your tool properly and for intended purpose, you will enjoy years of safe, reliable service.

NEED HELP? CONTACT US!

Have product questions? Need technical support?
Please feel free to contact us at:

 **800-232-1195** (M-F 8AM-5PM CST)

 techsupport@wenproducts.com

 WENPRODUCTS.COM



TABLE OF CONTENTS

Technical Data	2
General Safety Rules	3
Specific Safety Rules for Compressors	4
Electrical Information	5
Know Your Compressor	6
Operation	7
Maintenance	8
Troubleshooting	9
Parts List & Exploded View	10
Warranty	12

TECHNICAL DATA

Model Number:	2289
Motor:	120V, 1.5 HP, 15A, 60 Hz
Capacity:	10 Gallon
Max PSI	150 PSI
Air Outlet:	Quick-Coupler, 1/4" NPT
Air Flow:	4.0 CFM at 90 PSI 5.0 CFM at 40 PSI
Pump:	Oil Free
Compression Process:	Single Stage
Product Dimensions:	15 x 16 x 32 inches
Weight:	72 pounds

GENERAL SAFETY RULES

Safety is a combination of common sense, staying alert and knowing how your item works. **SAVE THESE SAFETY INSTRUCTIONS.**

WARNING: To avoid mistakes and serious injury, do not plug in your tool until the following steps have been read and understood.

1. **READ** and become familiar with this entire instruction manual. **LEARN** the tool's applications, limitations, and possible hazards.

2. **AVOID DANGEROUS CONDITIONS.** Do not use tools in wet or damp areas or expose them to rain. **Keep** work areas well lit.

3. **DO NOT** use tools in the presence of flammable liquids or gases.

4. **ALWAYS** keep your work area clean, uncluttered, and well lit. **DO NOT** work on floor surfaces that are slippery with sawdust or wax.

5. **KEEP BYSTANDERS AT A SAFE DISTANCE** from the work area, especially when the tool is operating. **NEVER** allow children or pets near the tool.

6. **DO NOT FORCE THE TOOL** to do a job for which it was not designed.

7. **DRESS FOR SAFETY.** Do not wear loose clothing, gloves, neckties, or jewelry (rings, watches, etc.) when operating the tool. Inappropriate clothing and items can get caught in moving parts and draw you in. **ALWAYS** wear non-slip footwear and tie back long hair.

8. **SERVICING** requires extreme care and knowledge of the tool. This should only be performed by a qualified service technician. When servicing, use only identical **WEN** replacement parts.

9. **ALWAYS** remove the power cord plug from the electrical outlet when making adjustments, changing parts, cleaning, or working on the tool.

10. **KEEP GUARDS IN PLACE AND IN WORKING ORDER.**

11. **AVOID ACCIDENTAL START-UPS.** Make sure the power switch is in the **OFF** position before plugging in the power cord.

12. **REMOVE ADJUSTMENT TOOLS.** Always make sure all adjustment tools are removed from the tool before turning it on.

13. **NEVER LEAVE A RUNNING TOOL UNATTENDED.** Turn the power switch to **OFF**. Do not leave the tool until it has come to a complete stop.

14. **NEVER STAND ON A TOOL.** Serious injury could result if the tool tips or is accidentally hit. **DO NOT** store anything above or near the tool.

15. **DO NOT OVERREACH.** Keep proper footing and balance at all times. Wear oil-resistant rubber-soled footwear. **Keep** the floor clear of oil, scrap, and other debris.

GENERAL SAFETY RULES

16. **MAINTAIN TOOLS PROPERLY. ALWAYS** keep tools clean and in good working order. Follow instructions for lubricating and changing accessories.
17. **CHECK FOR DAMAGED PARTS.** Check for alignment of moving parts, jamming, breakage, improper mounting, or any other conditions that may affect the tool's operation. Any part that is damaged should be properly repaired or replaced before use.
18. **MAKE THE WORKSHOP CHILDPROOF.** Use padlocks and master switches and **ALWAYS** remove starter keys.
19. **DO NOT** operate the tool if you are under the influence of drugs, alcohol, or medication that may affect your ability to properly use the tool.
20. **USE SAFETY GOGGLES AT ALL TIMES** that comply with ANSI Z87.1. Normal safety glasses only have impact resistant lenses and are not designed for safety. Wear a face or dust mask when working in a dusty environment. Use ear protection such as plugs or muffs during extended periods of operation.

SPECIFIC RULES FOR AIR COMPRESSORS

Safety is a combination of common sense, staying alert and knowing how your item works. **SAVE THESE SAFETY INSTRUCTIONS.**

WARNING: To avoid mistakes and serious injury, do not plug in your tool until the following steps have been read and understood.

1. Do not use your air compressor if the switch does not turn on and off. An air compressor that cannot be controlled with the switch is dangerous and must be repaired.
2. Disconnect the plug from the power source and drain all air from the tank before making any adjustments, changing accessories, or storing your air compressor. This reduces the risk of starting your air compressor accidentally.
3. Store your air compressor out of the reach of children and do not allow people unfamiliar with either the compressor or these instructions to operate it. An air compressor is dangerous in the hands of an untrained user.
4. Maintain your air compressor. Keep your air compressor clean for maximum performance. Follow the instruction for maintenance and changing accessories if necessary. Keep your air compressor dry, clean and free from oil and grease.
5. Check for misalignment or binding of moving parts, breakage of parts and any other condition that may affect your air compressor's operation. If damaged, have your air compressor repaired by a qualified service technician before using it again. Many accidents are caused by poorly maintained compressors.
6. Use your air compressor in accordance with these instructions, taking into account working conditions and the task at hand. Use of the compressor for operations other than its intended use could result in personal injury.
7. Do not spray flammable liquids in a confined area or towards a hot surface. The spray area must be well-ventilated. Do not smoke while spraying. Do not spray when a spark or flame is present.

SPECIFIC RULES FOR AIR COMPRESSORS

8. Keep your air compressor at least 20 feet away from explosive vapors.
9. Do not adjust the regulator higher than the marked maximum pressure of any attached pneumatic tools or equipment.
10. Do not direct the air stream at people or animals.
11. Do not use to supply breathing air.
12. Do not leave your air compressor unattended for an extended period while plugged in. Unplug compressor and detach hoses and accessories after use.
13. Keep your air compressor in a well-ventilated area. Do not cover during use.
14. Drain tank daily or after use. Internal rust causes tank failures and explosions.
15. You air compressor's cylinder head and air lines get hot during operation. Do not touch these parts and do not let children nearby during or immediately after operation.
16. Do not use the air hose to move your air compressor.
17. Do not grind, puncture, torch or in anyway modify the compressor's tank.
18. Ignoring any of the above rules and guidelines automatically voids the warranty for the unit.

ELECTRICAL INFORMATION

GROUNDING INSTRUCTIONS

IN THE EVENT OF A MALFUNCTION OR BREAKDOWN, grounding provides the path of least resistance for an electric current and reduces the risk of electric shock. This tool is equipped with an electric cord that has an equipment grounding conductor and a grounding plug. The plug **MUST** be plugged into a matching outlet that is properly installed and grounded in accordance with **ALL** local codes and ordinances.

DO NOT MODIFY THE PLUG PROVIDED. If it will not fit the outlet, have the proper outlet installed by a licensed electrician.

IMPROPER CONNECTION of the equipment grounding conductor can result in electric shock. The conductor with the green insulation (with or without yellow stripes) is the equipment grounding conductor. If repair or replacement of the electric cord or plug is necessary, **DO NOT** connect the equipment grounding conductor to a live terminal.

CHECK with a licensed electrician or service personnel if you do not completely understand the grounding instructions or whether the tool is properly grounded.

CAUTION: In all cases, make certain the outlet in question is properly grounded. If you are not sure, have a licensed electrician check the outlet.



WARNING: This tool is for indoor use only. Do not expose to rain or use in damp locations.

ELECTRICAL INFORMATION

GUIDELINES FOR EXTENSION CORDS

Make sure your extension cord is in good condition. When using an extension cord, be sure to use one heavy enough to carry the current your product will draw. An undersized cord will cause a drop in line voltage resulting in loss of power and overheating. The table below shows the correct size to be used according to cord length and nameplate ampere rating. When in doubt, use a heavier cord. The smaller the gauge number, the heavier the cord.

Make sure your extension cord is properly wired and in good condition. Always replace a damaged extension cord or have it repaired by a qualified person before using it.

Protect your extension cords from sharp objects, excessive heat and damp/wet areas.

Use a separate electrical circuit for your tools. This circuit must not be less than a #12 wire and should be protected with a 15 A time-delayed fuse. Before connecting the motor to the power line, make sure the switch is in the OFF position and the electric current is rated the same as the current stamped on the motor nameplate. Running at a lower voltage will damage the motor.

WARNING: This tool must be grounded while in use to protect the operator from electric shock.

AMPERAGE	REQUIRED GAUGE FOR EXTENSION CORDS (UL Recommendations)			
	25 ft.	50 ft.	100 ft.	150 ft.
15 A	14 gauge	12 gauge	Not Recommended	Not Recommended

KNOW YOUR COMPRESSOR

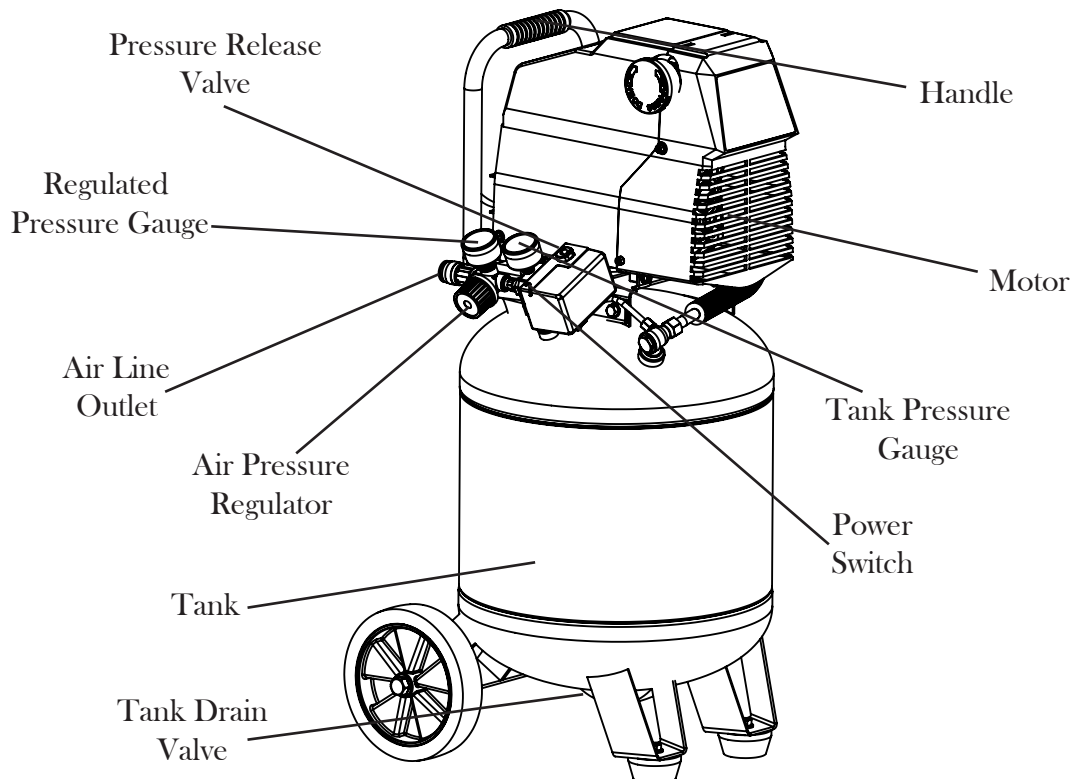

OPERATION

1. Connect an air hose (not included) to the air line inlet. Make sure the air hose is rated high enough to meet the max PSI of the compressor.
2. Connect the electrical plug to a power supply. **NOTE:** the compressor must be at least one foot from any wall or obstruction in a well-ventilated area in order to maximize proper air flow. Do not cover the compressor.
3. After making sure that the tank drain valve is shut, turn the power switch to the **ON** position to allow the compressor to automatically start up and shut down depending on the need for air. **NOTE:** make sure this switch is set to **OFF** before unplugging, plugging in, or storing the compressor.
4. Allow the compressor to reach the desired **PSI** on the tank pressure gauge before turning off the compressor. If left on, the compressor will automatically reach its maximum **PSI** of 150 before turning off. Then, the compressor will automatically turn back on once the tank **PSI** gets too low until it reaches its max **PSI** again. **DO NOT ALLOW THE COMPRESSOR TO FILL UP TO MORE THAN 150 PSI.**
5. Turn the air pressure regulator to the desired position in order to control the output of air flow from the compressor. The regulated air pressure gauge will show you the current air flow from the air line outlet. Make sure that this pressure is not higher than the working pressure of any pneumatic tools hooked up to the compressor. Using a pressure higher than the rated pressure of an attached tool creates the possibility of damaging or, in worse case scenarios, bursting said power tool. Using a pressure that is too low for a tool can result in misfires and improper functionality.
6. To shut off the compressor, turn the power switch to the **OFF** position before unplugging the power cord.
7. Before storing the compressor, drain the tank by opening tank drain valve on the underside of the compressor. This will drain the compressor to prevent moisture from collecting and rusting the inside of the tank. Pulling on the air release valve located next to the tank pressure gauge will quickly empty out the tank. Do not store in cold climates, as cold climates may create problems with the motor while possibly freezing water condensation.

MAINTENANCE

CLEAN AND INSPECT DAILY

CAUTION - Disconnect tool from power supply before cleaning and inspection. Correct all problems before operation.

Oil-free operation requires no external lubrication. Open the air release valve after operation to drain water and contaminations out. Wipe the tool clean. Blow the tool clean using high compressed air, then use non-flammable cleaning solutions to wipe exterior of the tool as necessary, particularly before storage. Do not soak tool with cleaning solutions. Such solutions can damage internal parts. Keep the handle clean, dry and free from slippery substances such as oil or grease.

Do not overtighten connections to avoid creating leaks.

Inspect the machine components before operation to make sure that there are no damaged or worn parts. Replace any damaged parts immediately. Do not operate if there are any damaged components. Only repair using identical replacement parts.

Drain the tank daily after use. To minimize moisture inside of the unit, tip the compressor during drainage so that the drain valve is aimed directly towards the ground. This will allow all moisture to collect at the bottom of the compressor and drain completely.

TESTING FOR LEAKS

Make sure all connections are tight and secure before testing for leaks. A small leak in any hoses or connectors will greatly reduce the abilities of the compressor. To locate a leak, simply spray a mixture of soap and water across the entire surface of both the tank and the hose (wherever the leak is believed to be). Bubbles will begin to appear if a leak is indeed present. Fix immediately. Try to avoid getting soapy water near any of the inlets on the tank or the pump.

TROUBLESHOOTING



CAUTION: Stop using the tool immediately if any of the following problems occur or risk serious personal injury. Repairs and replacements should only be performed by authorized personnel at a certified WEN service center.

Problem	Common Causes	Solution
Air leaks from the regulator. Regulator does not regulate pressure any more.	The regulator has become damaged or dirty.	Replace the regulator/internal parts.
Low PSI pressure and/or compressor does not stop.	<ol style="list-style-type: none"> 1. Tank drain valve is open. 2. Leaks in the unit. 3. Using too much air 4. Air intake obstructed. 5. Compressor is too small. 6. Blown gaskets or seals or leaking valves or piston rings. 	<ol style="list-style-type: none"> 1. Close the drain valve. 2. Check the unit for leaks (see “Testing for Leaks” on page 8). 3. Use less air. 4. Make sure the unit is away from the wall and that the air inlets are not obstructed. 5. Check the requirements of the pneumatic tool. Make sure the specifications of this compressor meet the requirements. 6. Replace necessary parts.
A large drop in the regulated pressure gauge occurs once a pneumatic tool or other air accessory is being used.	The compressor is too small.	Check the requirements of the pneumatic tool. Make sure the specifications of this compressor meet the requirements.
Motor won't run.	<ol style="list-style-type: none"> 1. Tank pressure is too high. 2. Motor overload protection has been tripped. 3. Power source isn't working. 4. Check valve stuck open. 	<ol style="list-style-type: none"> 1. Motor will start automatically once the tank pressure drops. 2. Let the motor cool down for a few minutes to reset the overload switch. 3. Examine the power source. Make sure that your extension cord is a high enough gauge. 4. Clean or replace the check valve.
Pressure relief valve opens.	Either the tank pressure is too high or the pressure switch is stuck.	Replace the pressure switch.

If there are still problems after consulting this list, or if you have any questions about the solutions provided above, feel free to contact the WEN help line at 800-232-1195 (M to F, 8 to 5 CST).

EXPLODED VIEW AND PARTS LIST

No.	Part Number	Description	Qty.
1	2289-001	Pump Assembly	1
2	2289-002	Rubber Foot	2
3	2289-003	Shroud Front	1
4	2289-004	Shroud Rear	1
5	2289-005	Air Filter Intake Metal Housing 1/2"-14 NPT	1
6	2289-006	6' Power Cord	1
7	2289-007	Pressure Switch 4-Port 120-150 PSI	1
8	2289-008	Pressure Gauge 1/4" NPT	2
9	2289-009	Safety Valve	1
10	2289-010	Drain Valve	1
11	2289-011	Check Valve	1
12	2289-012	Regulator 3-Port 1/4" NPT	1
13	2289-013	Quick Connect Fitting	1
14	2289-014	Nipple 1/4" NPT 35mm	1
15	2289-015	Nipple 1/4" NPT 43mm	1
16	2289-016	Exhaust Elbow	1
17	2289-017	3/8" Ferrule Tubing	2
18	2289-018	1/4" Ferrule Tubing	2
19	2289-019	3/8" Nut 9/16" UNEF	2
20	2289-020	1/4" Nut 7/16" UNS	2
21	2289-021	Relief Tube	1
22	2289-022	Outlet Tube	1
23	2289-023	10-Gallon Tank	1
24	2289-024	Handle	1
25	2289-025	Rubber Grip 20mm	1
26	2289-026	Wheel 175mm	2
27	2289-027	Bolt M10X1.25X55	2
28	2289-028	Hex Bolt M8X1.25X25mm	4
29	2289-029	Hex Bolt M8X1.25X20mm	6
30	2289-030	Hex Bolt M6X1.0X20	2
31	2289-031	Hex Bolt M6X1X12mm	6
32	2289-032	Hex Nut M8	6
33	2289-033	Nylon Hex Nut M10X1.25	2
34	2289-034	Flat Washer M10	2
35	2289-035	Flat Wahser 6mm	2
36	2289-036	Flat Washer 8mm	10
37	2289-037	Lock Washer 6mm	2
38	2289-038	Lock Washer M8	8

EXPLODED VIEW AND PARTS LIST

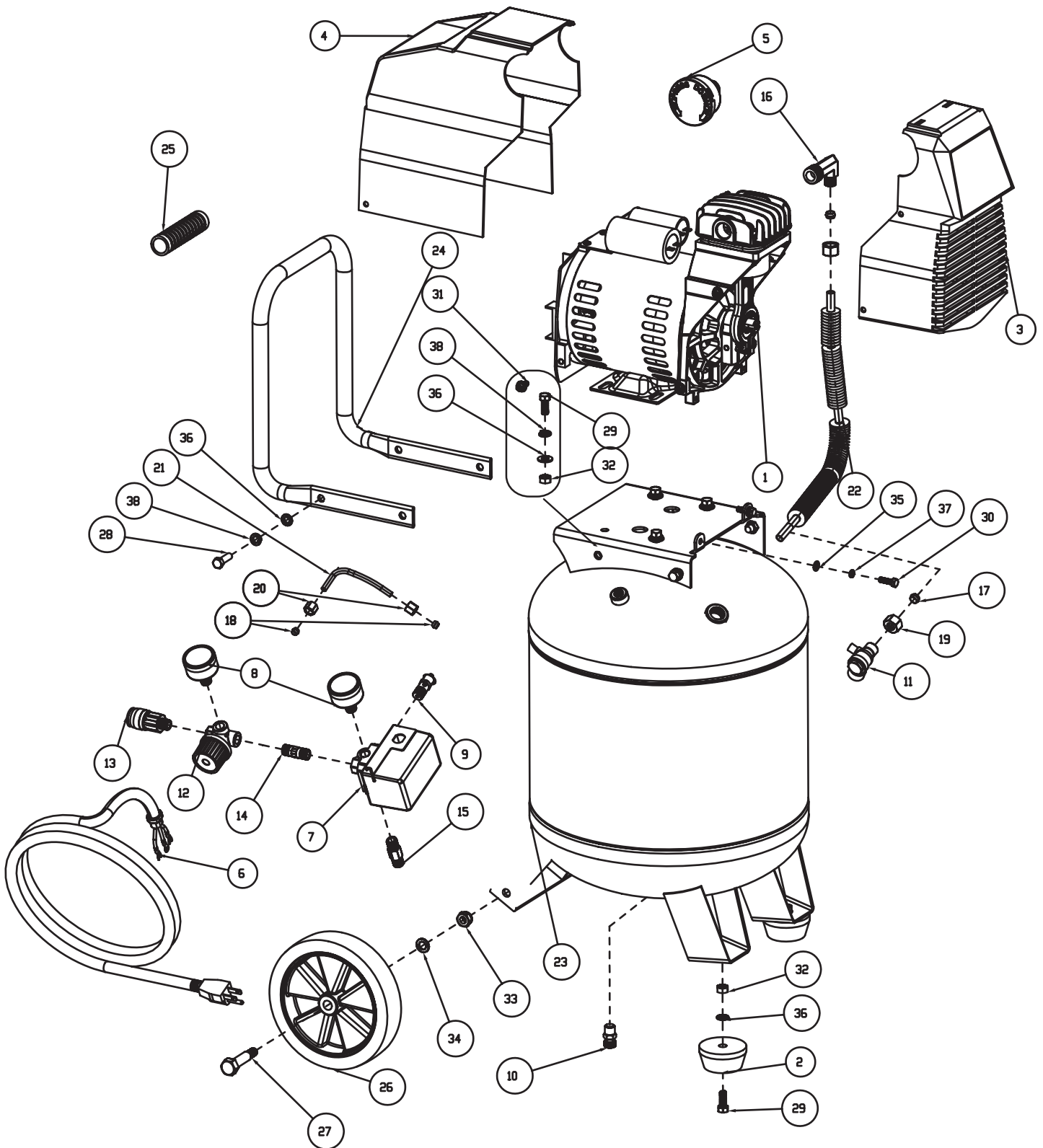

LIMITED TWO YEAR WARRANTY

WEN Products is committed to building tools that are dependable for years. Our warranties are consistent with this commitment and our dedication to quality.

LIMITED WARRANTY OF WEN CONSUMER POWER TOOLS PRODUCTS FOR HOME USE

GREAT LAKES TECHNOLOGIES, LLC (“Seller”) warrants to the original purchaser only, that all WEN consumer power tools will be free from defects in material or workmanship for a period of two (2) years from date of purchase. Ninety days for all WEN products, if the tool is used for professional use.

SELLER’S SOLE OBLIGATION AND YOUR EXCLUSIVE REMEDY under this Limited Warranty and, to the extent permitted by law, any warranty or condition implied by law, shall be the repair or replacement of parts, without charge, which are defective in material or workmanship and which have not been misused, carelessly handled, or misrepaired by persons other than Seller or Authorized Service Center. To make a claim under this Limited Warranty, you must make sure to keep a copy of your proof of purchase that clearly defines the Date of Purchase (month and year) and the Place of Purchase. Place of purchase must be a direct vendor of Great Lakes Technologies, LLC. Third party vendors such as garage sales, pawn shops, resale shops, or any other secondhand merchant void the warranty included with this product. Contact techsupport@wenproducts.com or 1-800-232-1195 to make arrangements for repairs and transportation.

When returning a product for warranty service, the shipping charges must be prepaid by the purchaser. The product must be shipped in its original container (or an equivalent), properly packed to withstand the hazards of shipment. The product must be fully insured with a copy of the warranty card and/or the proof of purchase enclosed. There must also be a description of the problem in order to help our repairs department diagnose and fix the issue. Repairs will be made and the product will be returned and shipped back to the purchaser at no charge.

THIS LIMITED WARRANTY DOES NOT APPLY TO ACCESSORY ITEMS THAT WEAR OUT FROM REGULAR USAGE OVER TIME INCLUDING BELTS, BRUSHES, BLADES, ETC.

ANY IMPLIED WARRANTIES SHALL BE LIMITED IN DURATION TO TWO (2) YEARS FROM DATE OF PURCHASE. SOME STATES IN THE U.S., SOME CANADIAN PROVINCES DO NOT ALLOW LIMITATIONS ON HOW LONG AN IMPLIED WARRANTY LASTS, SO THE ABOVE LIMITATION MAY NOT APPLY TO YOU.

IN NO EVENT SHALL SELLER BE LIABLE FOR ANY INCIDENTAL OR CONSEQUENTIAL DAMAGES (INCLUDING BUT NOT LIMITED TO LIABILITY FOR LOSS OF PROFITS) ARISING FROM THE SALE OR USE OF THIS PRODUCT. SOME STATES IN THE U.S. AND SOME CANADIAN PROVINCES DO NOT ALLOW THE EXCLUSION OR LIMITATION OF INCIDENTAL OR CONSEQUENTIAL DAMAGES, SO THE ABOVE LIMITATION OR EXCLUSION MAY NOT APPLY TO YOU.

THIS LIMITED WARRANTY GIVES YOU SPECIFIC LEGAL RIGHTS, AND YOU MAY ALSO HAVE OTHER RIGHTS WHICH VARY FROM STATE TO STATE IN THE U.S., PROVINCE TO PROVINCE IN CANADA AND FROM COUNTRY TO COUNTRY.

THIS LIMITED WARRANTY APPLIES ONLY TO PORTABLE ELECTRIC TOOLS, BENCH POWER TOOLS, OUTDOOR POWER EQUIPMENT AND PNEUMATIC TOOLS SOLD WITHIN THE UNITED STATES OF AMERICA, CANADA AND THE COMMONWEALTH OF PUERTO RICO. FOR WARRANTY COVERAGE WITHIN OTHER COUNTRIES, CONTACT THE WEN CUSTOMER SUPPORT LINE.