

# Quick Start Guide



for Magnum Shear Models #909, #913, #920, #926

## In the Box:

- (1) Power Assembly
- (1) Handle Assembly
- (1) Fence
- (1) Table
- (1) Tail
- (2) Rails
- (1) Hone Stone
- (1) Hardware Kit

## In the Hardware Kit:

- Item A. (4) 8mm x 60mm PH Phillips Machine Screws
- Item B. (4) M8 Star Washers
- Item C. (4) 8mm x 25mm PH Phillips Machine Screws
- Item D. (6) 6mm x 16mm PH Phillips Machine Screws
- Item E. (5) #10 x 1 PH Phillips Self Tapping Screws
- Item F. (1) M16 x 50 BHCS (Pre-Installed in Cam)
- Item G. (1) 10mm Hex Wrench

The Hardware Kit is used in multiple models. Your Shear may not use all of the items listed.

## ASSEMBLING YOUR SHEAR

Tools needed: #2 & #3 Phillips head screwdrivers.

**IMPORTANT! Start all screws BY HAND when assembling your shear. This will help avoid cross-threading.**

### 1. ATTACH RAILS

Attach rails to Power Assembly base using *Item A* screws, fitted with *Item B* star washers.

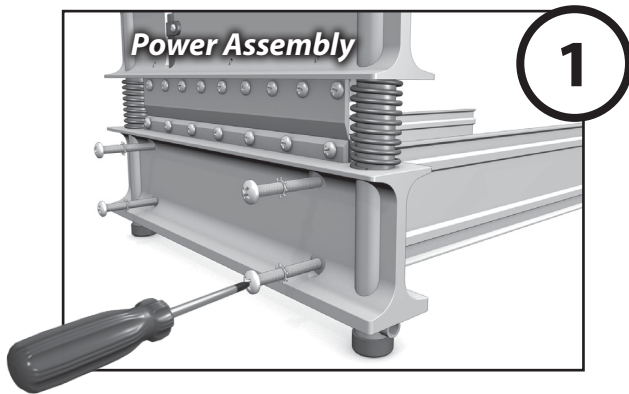

### 2. ATTACH TAIL

Attach tail to rails using *Item C* screws. Make sure holes in tail are facing up.

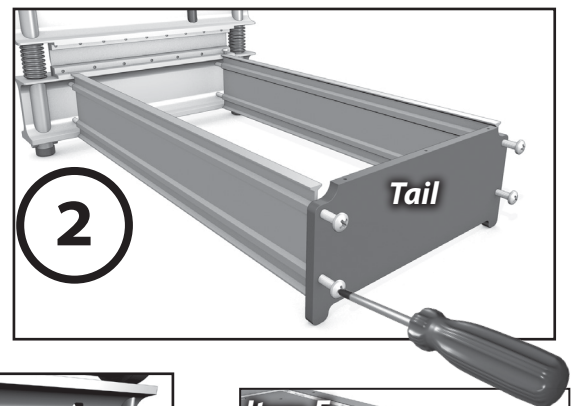

### 3. ATTACH TABLE

- A. Attach front of table to base, using *Item D* screws. Tighten with #3 Phillips.
- B. Attach back of table to tail using *Item E* screws. Tighten with #2 Phillips.

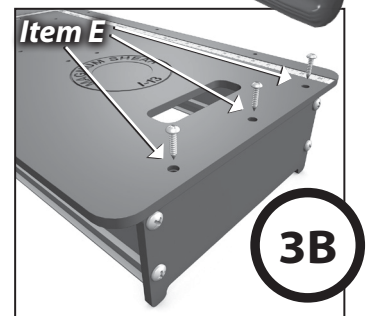
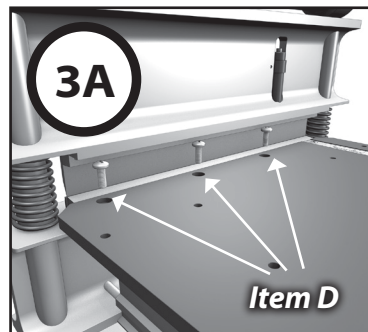

### 4. ATTACH HANDLE

Remove handle bolt *Item F* from handle, and install in camshaft. Insert handle into camshaft. *Note: Backstroke Stop must be on top!* Tighten with 10mm hex wrench *Item G*.

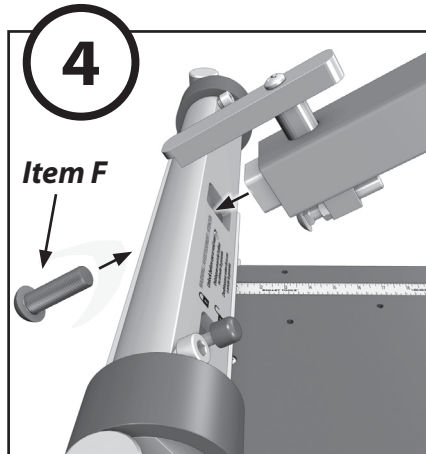

### 5. ATTACH FENCE

Insert fence into one of the six hole sets on the table: there are two 90° and four 45° locations. The fence is friction fit (requires effort to insert or remove).

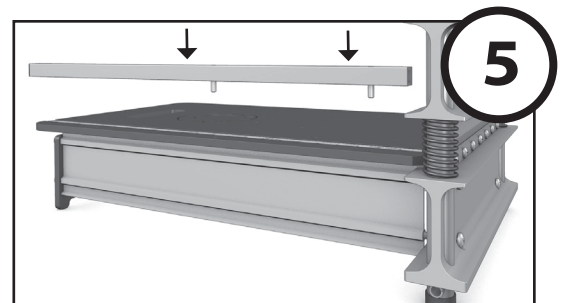

Do NOT remove plastic tie and orange tag until handle is bolted in place



HANDLE UNDER EXTREME PRESSURE DO NOT ALLOW TO SLAM BACK!

# USING YOUR SHEAR

**1**

While gently pushing handle down, slide Safety Lock over and down to the unlock position, then lift handle.

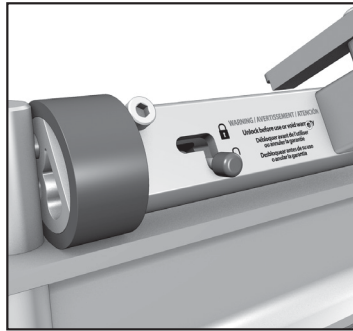

**2**

Place product on table. Bring handle down until blade touches material.

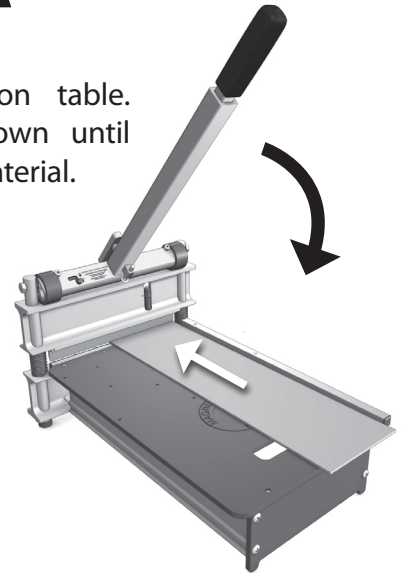

**3**

Push handle down until material is completely cut. If needed, extend handle.

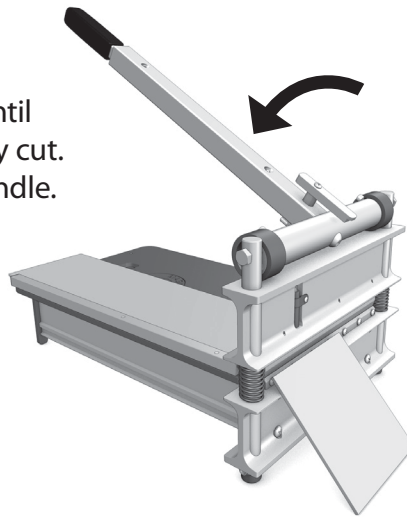

Your Magnum Shear cuts a wide variety of products. Please refer to cut guide for recommended products and thicknesses.

## FLOORING CUT GUIDE

Max Thickness = 1" or 25mm

### Material List

Laminate Flooring
Engineered Wood
Commercial Vinyl
Luxury Vinyl Tile
Parquet
PVC Tile
Rubber Tile
Soft Plastic

## SIDING CUT GUIDE

Max Thickness = 1" or 25mm

### Material List

Siding, Fiber Cement Board
Siding, Pressboard Lap
Siding, Vinyl
Siding, Wood
Trim, OSB
Trim, Fiber Cement
Trim, Vinyl
Shingles, Tar or Wood

For full manuals, warranty info, accessories, & tips on using and maintaining your Magnum Shear, go to [BulletTools.com](http://BulletTools.com) or scan the QR code below.

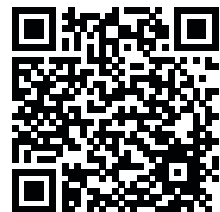

Please note: Approved materials may vary in density and hardness. If extreme pressure is required to cut a product, it may result in damage to your machine. Please contact Bullet Tools before proceeding. Warranty is void if an unapproved product damages the machine.