

OWNER'S MANUAL

ITEM: L-GZ411PST

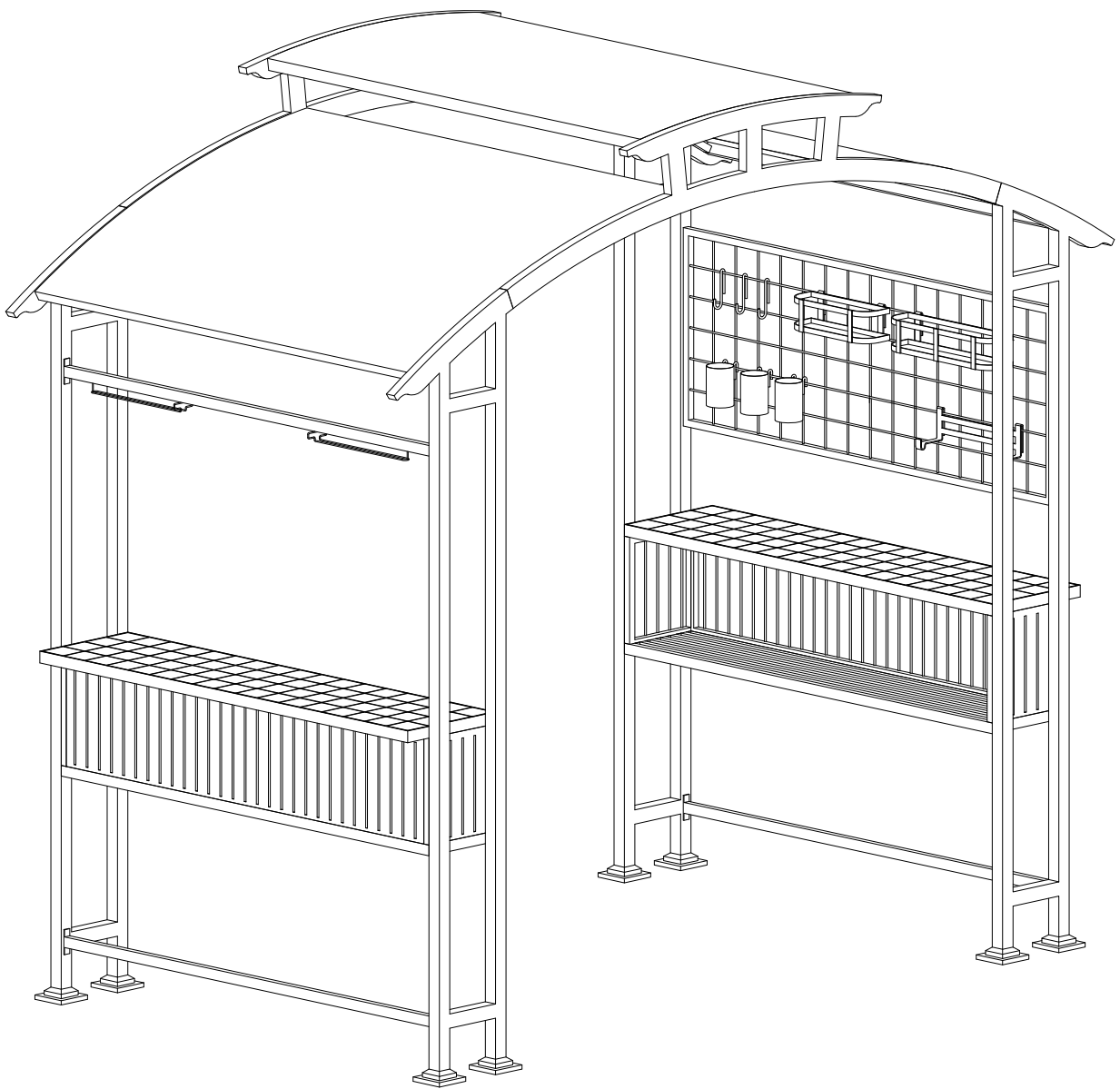





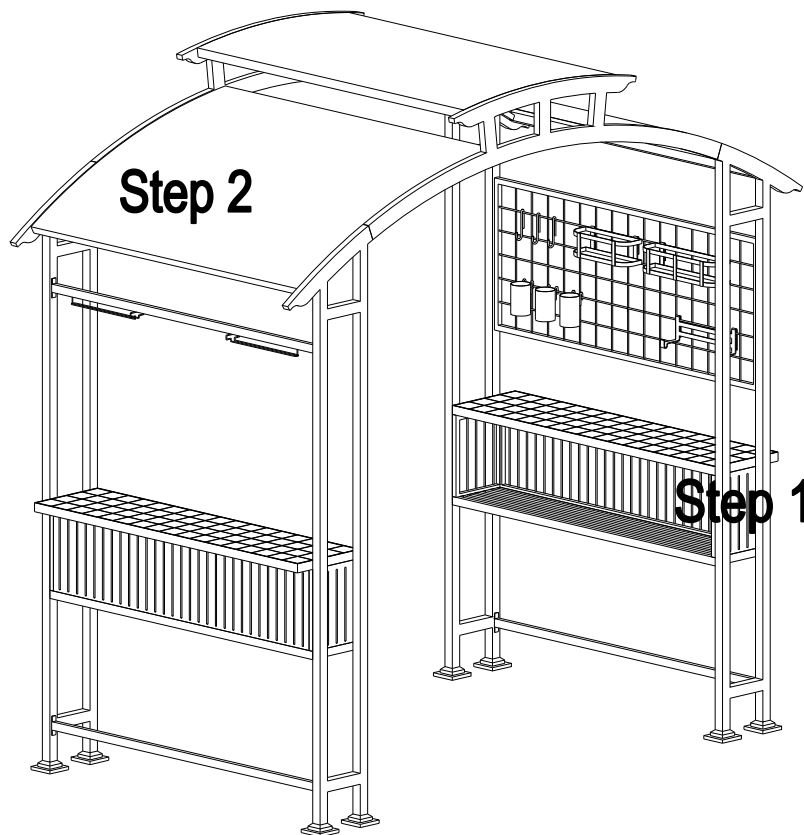



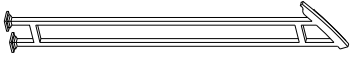
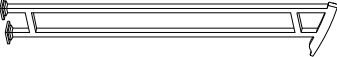

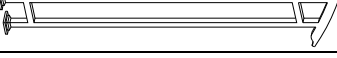

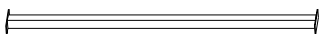

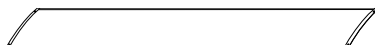

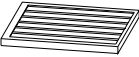
WARNING:

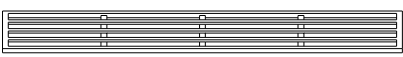
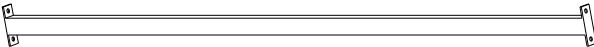
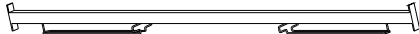
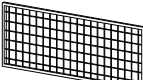
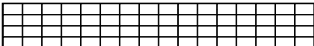

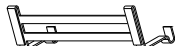
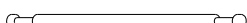

- 1. THIS UNIT IS HEAVY! For safety, DO NOT assemble this item alone.**
- 2. Keep all children and pets away from assembly area. Children and pets should be supervised when they are in the assembly area of the gazebo.**
- 3. Some parts may contain sharp edges. Wear protective gloves.**
- 4. When assembling and using this product, basic safety precautions should always be followed to reduce the risk of personal injury and damage to equipment. Please read all instructions before assembly and usage.**
- 5. For outdoor use only. Install on level ground.**
- 6. Check all bolts for tightness before and during usage.**
- 7. Do not leave the gazebo assembled when there is a risk of high wind, as possible damage will occur to the structure.**
- 8. Do not climb on top of the gazebo. Falling off the gazebo can result in serious injury, possibly even death.**

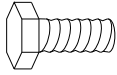

Parts List

Post 1	A	1	
Post 2	B	1	
Post 3	C	1	
Post 4	D	1	
Top beam	E	2	
Beam	F	1	
Hook	G	2	
Big cover	H	2	
Small cover	I	1	
Front panel	J	2	
Side panel 1	K1	2	
Side panel 2	K2	2	
Bottom board	L	2	
Post beam	M	2	
Wine Glass Holder	N	1	
Screen	O	1	
Table top	P	2	
Big rack	Q	1	
Small rack	R	1	
Napkin holder	S	1	
Paper towel holder	T	1	
Cup holder	U	3	
Utensil hook	V	3	
Connector	W	8	

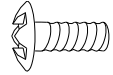
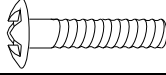
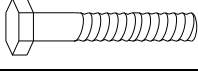
Hardware Pack 1

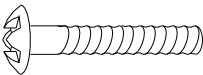
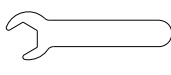
AA	M6X15 Bolt TBZ00106015HQ	24PCS	
BB	M6 Flat washer TBZ10406HQ	76PCS	
DD	M6X15 Bolt TBZ00306015HQ	24PCS	
EE	M6X25 Bolt TBZ00306025HQ	12PCS	
GG	M6X35 Stainless steel bolt TBZ00306035SS	4PCS	
HH	M6 Stainless steel flat washer TBZ10406SS	4PCS	
II	M6X35 Bolt TBZ00306035HQ	16PCS	
Z	M6 Wrench	2 PC	

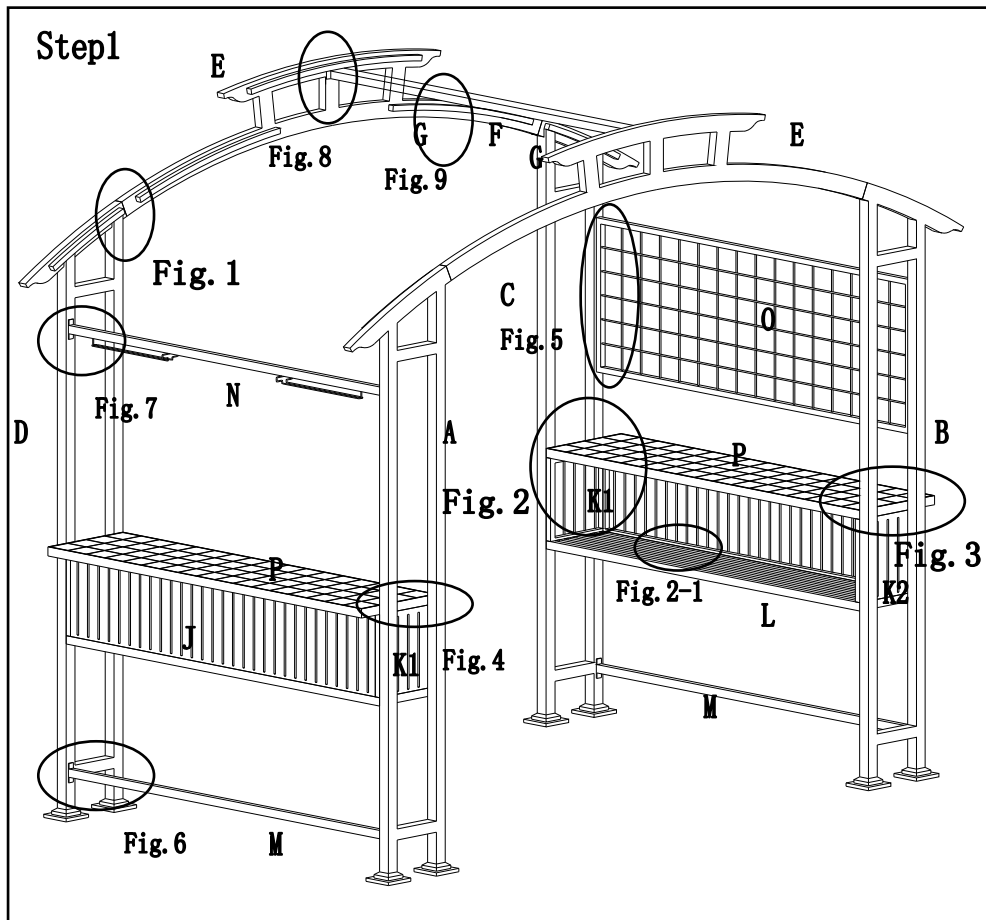

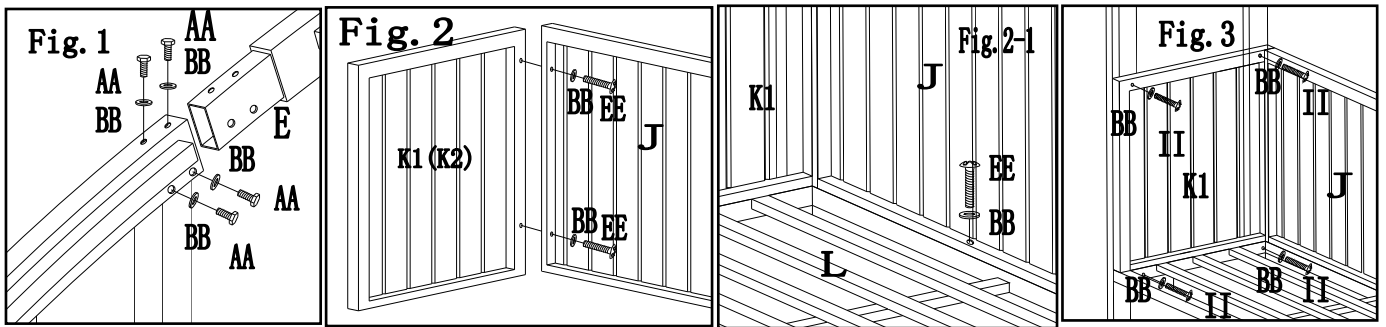

Fig 1: Insert Top beam (E) into Post 1 (A), Post 2 (B), Post 3 (C), Post 4 (D) with Flat washer (BB), Bolt (AA).
 Fig.2: Tighten Front panel (J), Side panel 1, 2 (K1、K2) by using Bolt (EE), Flat washer (BB).
 Fig.2-1: Tighten Front panel (J), Bottom board (L) by using Bolt (EE), Flat washer (BB).
 Fig.3: Take up the assembly frame, connect the assembly frame with post by using Bolt (II), Flat washer (BB).

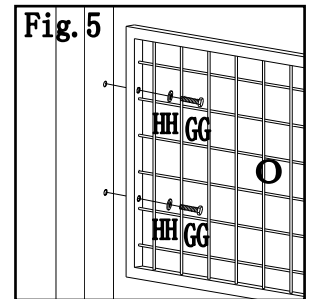
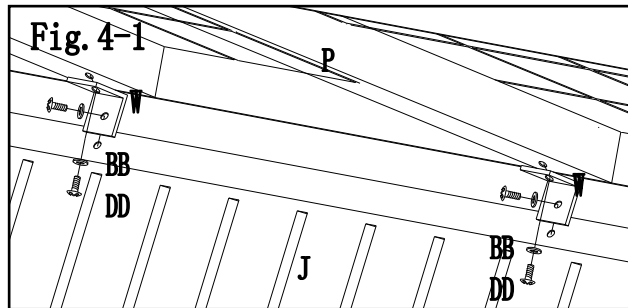
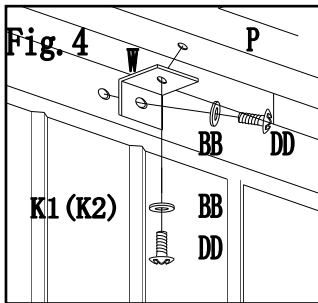

Fig4: Put Table top (P) onto the top of assembly frame. Tighten them with Connector (W), Bolt (DD), Flat washer (BB)
 Fig4-1: Tighten Table top (P) and Front panel (J) with Connector (W), Bolt (AA), Flat washer (BB)
 Fig5: Tighten Screen (O) onto the middle of Post 2 (B) and Post 3 (C) with Stainless steel bolt (GG), Stainless steel flat washer (HH).

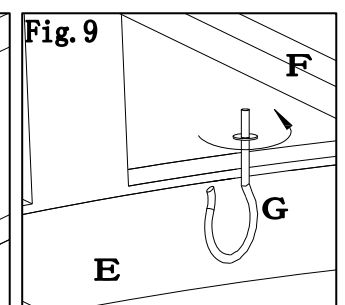
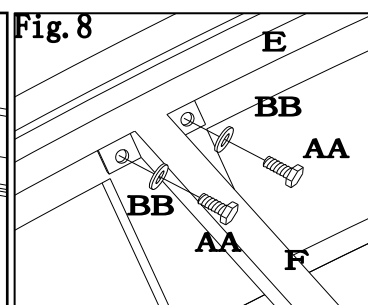
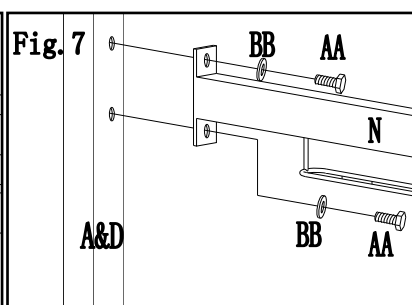
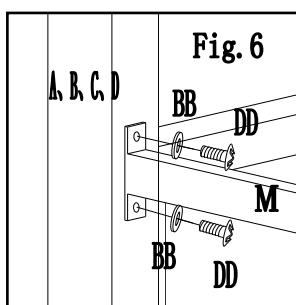

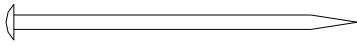

Fig6: Attach Post beam (M) onto the end of post with Bolt (DD), Flat washer (BB).
 Fig7: Tighten Wine Glass Holder (N) on the top of Post 1 (A) and Post 4 (D) with Bolt (AA), Flat washer (BB)
 Fig8: Attach Beam (F) onto Top beam (E) with Flat washer (BB), Bolt (AA)
 Fig9: Screw Hook (G) on Beam (F) as illustration.

Hardware Pack 2

CC	M6X25 Bolt TBZ00106025HQ	16 PCS	
BB	M6 Flat washer TBZ10406HQ	16PCS	
JJ	Ground stake $\phi 8 \times 180$	8 PCS	

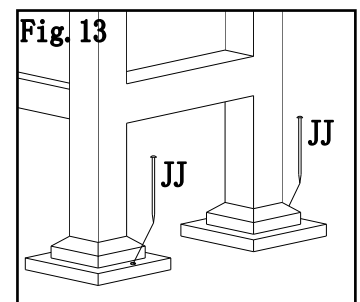
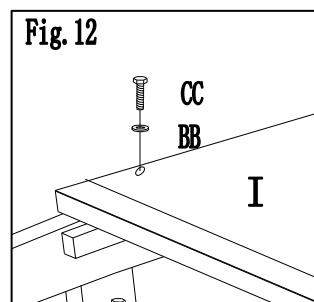
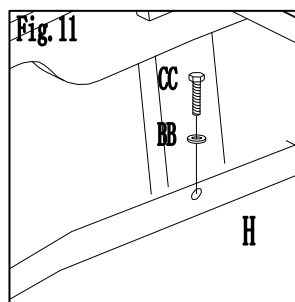
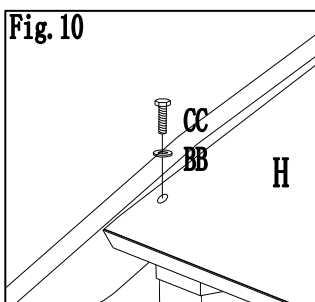
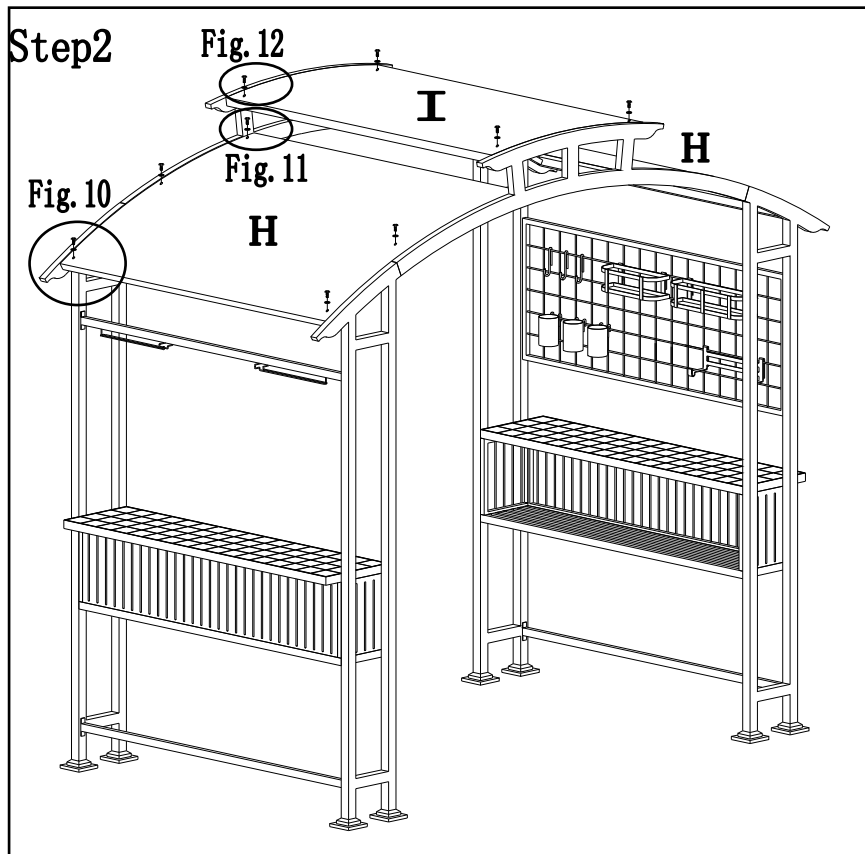

Fig10: Tighten Big cover (H) and the end side of frame (inside) as illustration Fig.10 with Bolt (CC), Flat washer (BB).

Fig11: Tighten Big cover (H) and the upper side of frame (inside) as illustration with Fig. 11 Bolt (CC), Flat washer (BB).

Fig12: Attach Small cover (I) onto Top beam (E) with Bolt (CC), Flat washer (BB).

Fig13: Secure the completely assembled Grill gazebo into the ground by using the Ground Stake (JJ).

MANUAL DEL PROPIETARIO

Modelo No. L-GZ411PST

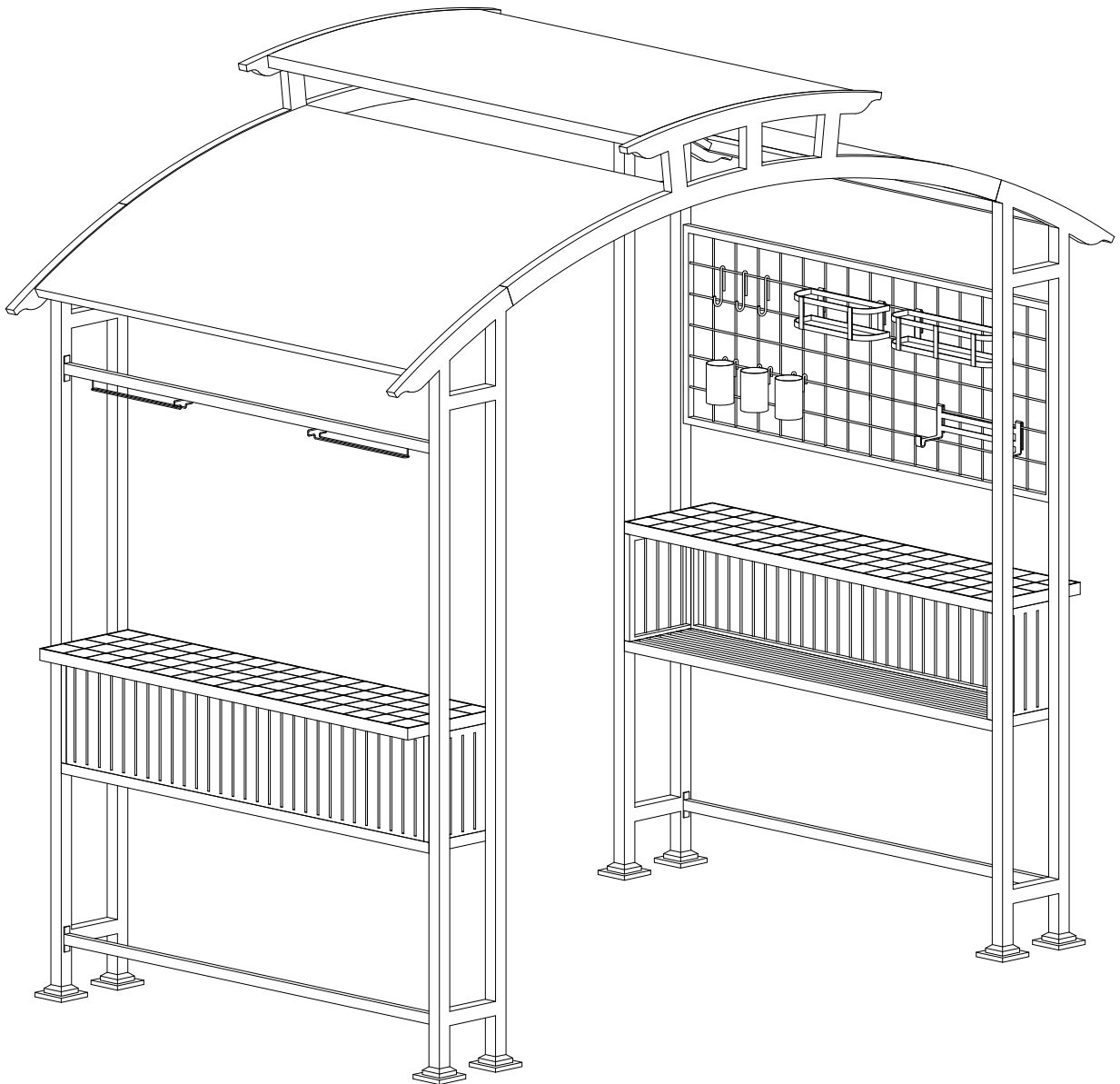





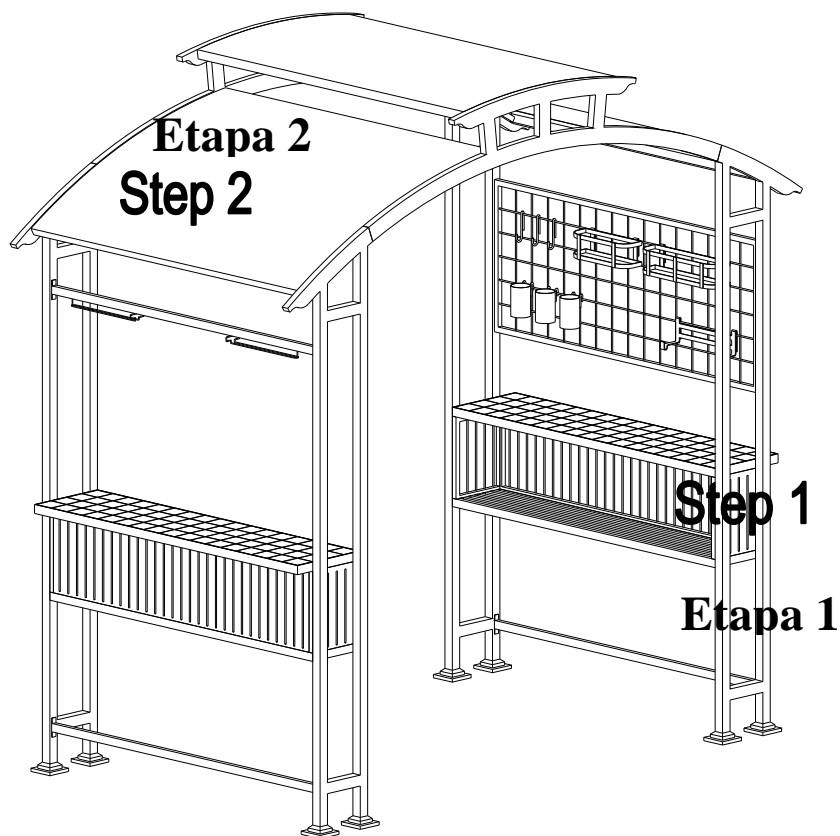







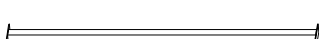
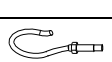
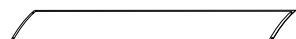
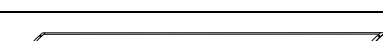
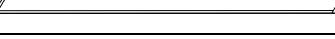

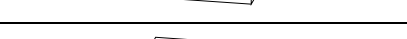

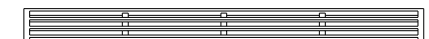
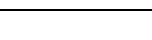
AVISO:



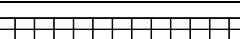

1. **¡ESTA UNIDAD ES MUY PESADA!** Para su seguridad, **NO MONTE** este artículo a solas.
2. Mantenga a niños y animales fuera de la zona de montaje. Los niños y animales se deben vigilar cuando están alrededor de la zona de montaje del pabellón.
3. Algunas piezas pueden tener bordes agudos. Póngase guantes de protección.
4. Mientras esté montando y utilizando este producto, tendrá que seguir siempre precauciones esenciales para evitar riesgos de lesiones personales o daños materiales. Por favor, léase todas las instrucciones antes de montar y utilizar.
5. Para uso exterior únicamente. Instale sobre una superficie a nivel.
6. Verifique todos los tornillos para asegurar que están fuertes antes y durante su empleo.
7. No deje el pabellón elevado cuando haya riesgos de vientos fuertes ya que podría causar daños a la estructura.
8. No se suba sobre el pabellón. Una caída de lo alto del pabellón puede provocar lesiones graves y hasta la muerte.

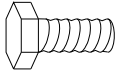

Lista de Piezas

Columna 1	A	1	
Columna 2	B	1	
Columna 3	C	1	
Columna 4	D	1	
Viga Superior	E	2	
Viga	F	1	
Gancho	G	2	
Techo Grande	H	2	
Techo Pequeño	I	1	
Panel Delantero	J	2	
Panel Lateral1	K1	2	
Panel Lateral 2	K2	2	
Repisa Inferior	L	2	
Viga de la Columna	M	2	
Porta Copas	N	1	
Partición	O	1	
Mesa	P	2	
Cesta Grande	Q	1	
Cesta Pequeña	R	1	
Porta Servilletas	S	1	
Porta Papel	T	1	
Porta Vaso	U	3	
Gancho para utensilios	V	3	
Conexión	W	8	

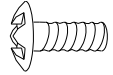
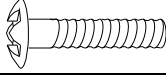
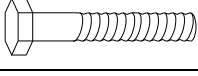
Bolsa de Ferrería 1

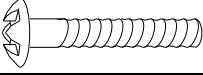
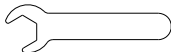
AA	Tornillo M6X15 TBZ00106015HQ	24 piezas	
BB	Arandela Plana M6 TBZ10406HQ	76 piezas	
DD	Tornillo M6X15 TBZ00306015HQ	24 piezas	
EE	Tornillo M6X25 TBZ00306025HQ	12 piezas	
GG	Tornillo de Acero Inoxidable M6X35 TBZ00306035SS	4 piezas	
HH	Arandela Plana de acero Inoxidable M6 TBZ10406SS	4 piezas	
II	Tornillo M6X35 TBZ00306035HQ	16 piezas	
Z	Llave M6	2 piezas	

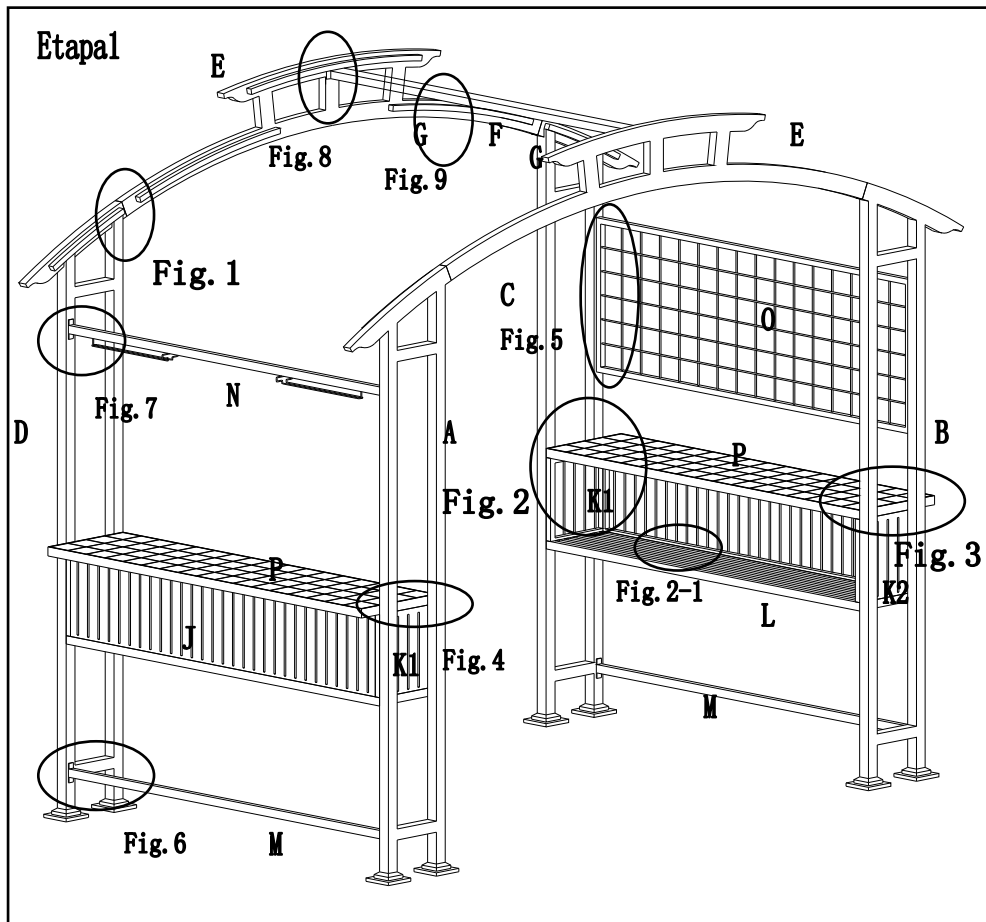

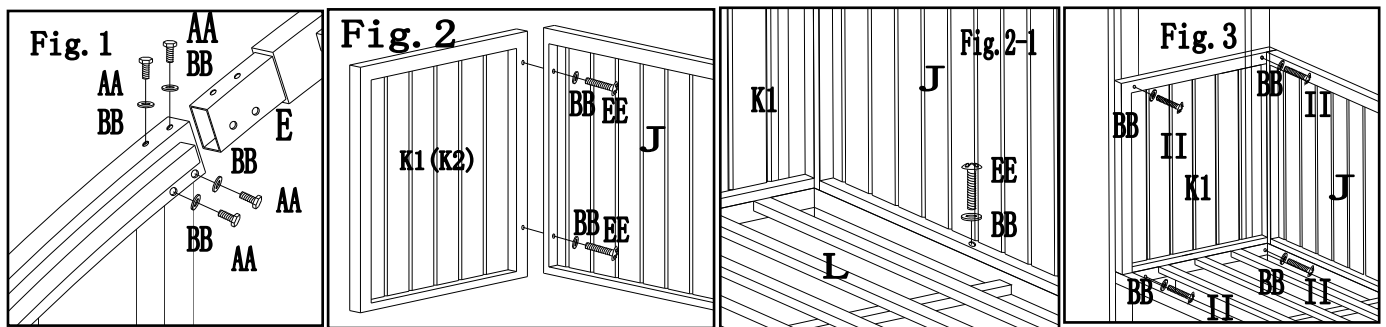

Fig. 1: Introduzca la Viga Superior (E) en la Columna 1 (A), Columna 2 (B), Columna 3 (C), Columna 4 (D) con Arandela Plana (BB), Tornillo (AA).

Fig.2: Fije el Panel Delantero (J), a los Paneles Laterales 1, 2 (K1, K2) con Tornillo (EE), Arandela Plana (BB).

Fig.2-1: Fije el Panel Delantero (J), a la Repisa Inferior (L) con Tornillo (EE), Arandela Plana (BB).

Fig.3: Levante la estructura montada, conecte la estructura a la columna con el Tornillo (II), y Arandela Plana (BB).

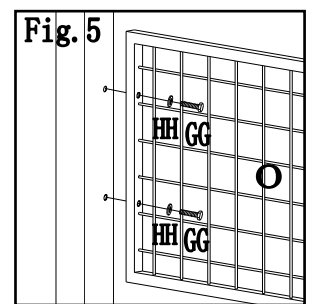
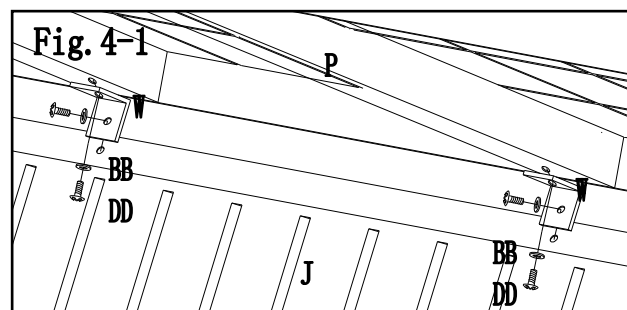
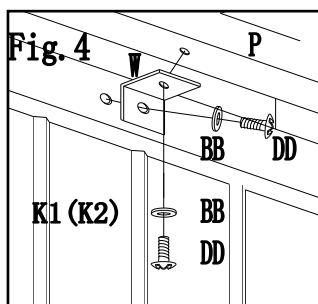

Fig4: Coloque la Mesa (P) sobre la estructura de la mesa. Fíjela con las Conexiones (W), y con Tornillo (DD), y Arandela Plana (BB)

Fig4-1: Fije la Mesa (P) al Panel Delantero (J) con las Conexiones (W), y con Tornillo (AA), y Arandela Plana (BB)

Fig5: Fije la Partición (O) al medio de la Columna 2 (B) y de la Columna 3 (C) con Tornillo de Acero Inoxidable (GG), y Arandela Plana de Acero Inoxidable (HH).

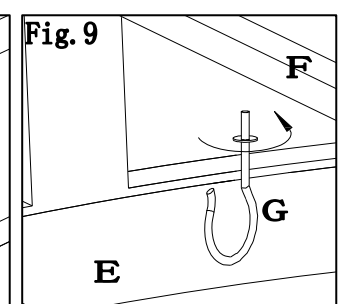
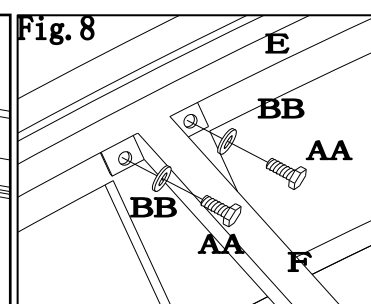
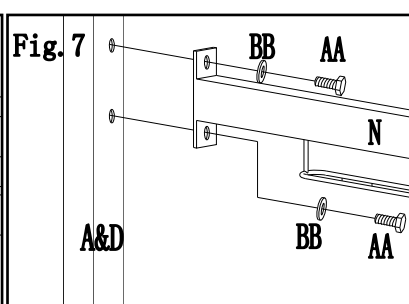
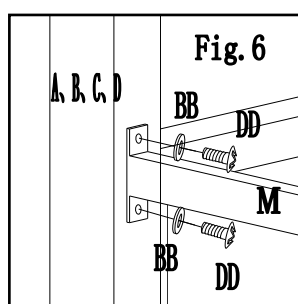



Fig6: Fije la Viga de la Columna (M) a la extremidad de la Columna con Tornillo (DD), y Arandela Plana (BB).

Fig7: Fije también el Porta Copas (N) en la parte superior de la Columna 1 (A) y Columna 4 (D) con Tornillo (AA), y Arandela Plana (BB)

Fig8: Fije la Viga (F) a la Viga Superior (E) con Arandela Plana (BB), y Tornillo (AA)

Fig9: Atornille el Gancho (G) sobre la Viga (F) como en la ilustración.

Bolsa de Ferrería 2

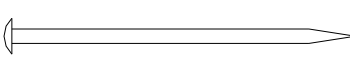
CC	Tornillo M6X25 TBZ00106025HQ	16 Piezas	
BB	Arandela Plana M6 TBZ10406HQ	16 Piezas	
JJ	Estaca $\phi 8 \times 180$	8 Piezas	

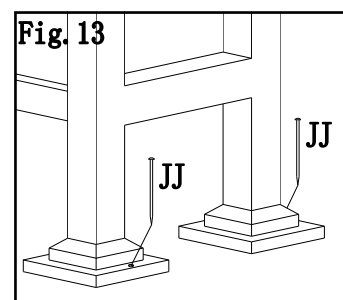
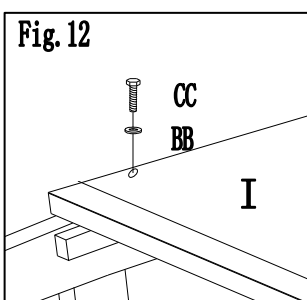
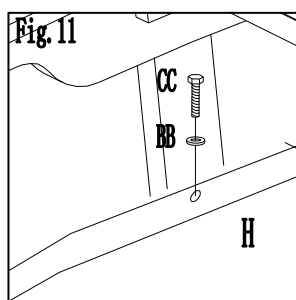
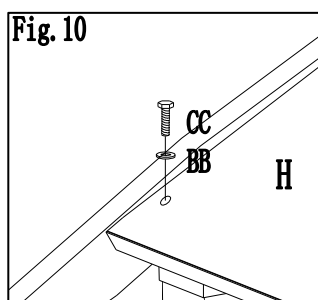
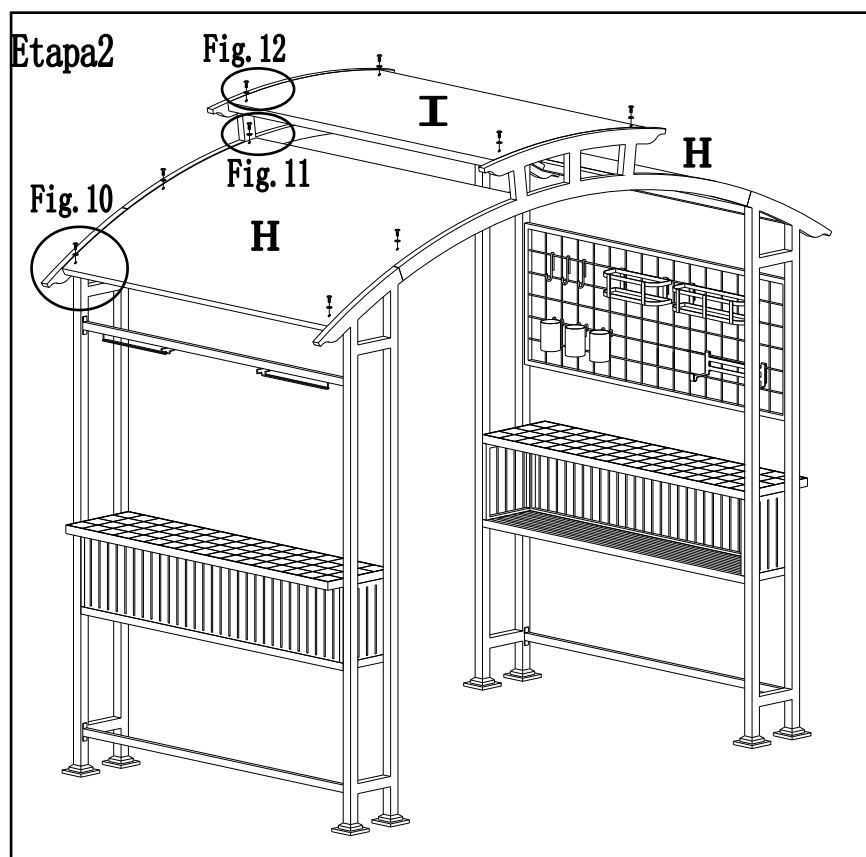

Fig10: Fije el Techo Grande (H) con la extremidad de la estructura (interior) como esta ilustrado en la Fig.10 con Tornillo (CC), y Arandela Plana (BB).

Fig11: Fije el Techo Grande (H) con la parte superior de la estructura (interior) como esta ilustrado en la Fig. 11 con Tornillo (CC), y Arandela Plana (BB).

Fig12: Fije el Techo Pequeño (I) sobre la Viga Superior (E) con Tornillo (CC), y Arandela Plana (BB).

Fig13: Ancle la estructura completa del Pabellón con Parrilla a la tierra con las Estacas (JJ).

Garantía Limitada:

Esta garantía limitada se extiende al comprador original y se aplica a defectos materiales y de mano de obra de nuestro producto, siempre y cuando el artículo haya sido mantenido con cuidado y utilizado para fines personales, residenciales.

Este artículo lleva la garantía de carecer de defectos materiales y de mano de obra durante un periodo de **6 meses**. No reembolsamos por gastos de transporte o de entrega, ni compensamos al individuo ni a ninguna persona ajena por el montaje o desmontaje del producto.

Exclusiones:

Los Artículos que hayan sido utilizados para uso comercial, bajo contrato, o para cualquier propósito que no sea residencial, o los artículos dañados por intemperies, vandalismo, uso o montaje inadecuado, no están cubiertos. La corrosión o el óxido de la ferretería no están cubiertos. Se requiere una prueba de compra (recibo fechado) para cualquier reclamación bajo garantía. La garantía es para el comprador original y no se puede traspasar. Cualquier sustitución de artículos garantizados será del estilo y color original, o de un estilo y color parecido si el original no está disponible o si ha sido discontinuado. Como algunos estados no permiten exclusiones o limitaciones sobre una garantía implícita, las exclusiones y limitaciones mencionadas pueden no aplicarse. Esta garantía le da derechos específicos, y podría usted tener también otros derechos, que varían de un estado al otro.

Mantenimiento:

Nuestros componentes de hierro/acero para accesorios y muebles de jardín están tratados con una pintura que impide y los protege del óxido. Sin embargo, debido a la naturaleza del acero, se puede producir óxido en la superficie cuando estas capas protectoras están arañadas. ¡Esto es un proceso natural y no es un defecto! Para reducir esta condición, recomendamos mucho cuidado al montar y manipular el producto para evitar arañar la pintura. El óxido en la superficie puede quitarse fácilmente con una aplicación ligera de aceite para cocinar común. Si se oxida la superficie y no se toman las medidas adecuadas para evitarlo, el óxido puede empezar a gotear sobre su suelo o patio y puede causar manchas perjudiciales, que serían difíciles de eliminar... Esto se puede impedir si se toman las medidas para evitar que se oxide el producto.

Importante: Para asistencia técnica sobre el montaje o piezas de recambio, por favor no devuelva este artículo a la tienda, llame a Sunjoy Industries (Industrias Sunjoy) al 1(866) 578-6569 entre las 8,30 y las 17,30, hora del Este, de Lunes a Viernes, o mande un fax con la hoja de pedido (incluida en el embalaje) al (740)-283-3549 o por correo electrónico a customer.care@sunjoygroup.com para asistencia.

Hecho en China

Limited Warranty:

This limited warranty is extended to the original purchaser and applies to defects in materials and workmanship of your item provided the item is maintained with care and used only for personal, residential purposes.

The item is warranted to be free from defects in material or workmanship for a period of **one (1) year**. We don't reimburse for transportation or delivery costs, or compensate the individual or any outside party for assembling or disassembling the product.

Exclusions:

Items used for commercial, contract, or other non-residential purposes, or items damaged due to acts of nature, vandalism, misuse, or improper assembly are not covered. Corrosion or rusting of hardware is not covered. Proof of purchase (dated register receipt) is required for warranty claims. Warranty is to the original purchaser and is non-transferable. Any replacement of warranted items will be in the original style and color, or a similar style and color if the original is unavailable or has been discontinued. As some states do not allow exclusions or limitations on an implied warranty, the above exclusions and limitations may not apply. This warranty gives you specific rights, and you may also have other rights, which vary from state to state.

Maintenance:

Our iron/steel components for garden accessories and furniture are coated with rust inhibiting paint that protects it from rusting. However, due to the nature of iron, surface oxidation (rusting) will occur once these protective coatings are scratched. This is a natural process and is not a defect! To minimize this condition, we recommend care when assembling & handling the product to prevent scratching the paint. Should any scratching or damage occur, we recommend immediate touch-up with rust inhibiting paint. Surface rust can also be easily removed with a very light application of common cooking oil. If surface oxidation (rusting) occurs and if no measure is taken to prevent this, the oxidation may start dripping on to deck or patio and cause damaging stains, which may be difficult to remove. This can be prevented if measure is taken to keep the product from oxidizing.

Important: For technical assistance on assembly or replacement parts Please do not return this product to the store, call Sunjoy Industries at 1(866) 578-6569 from 8:30 AM to 5:30 PM EST Monday to Friday or fax the replacement part form which put into the package to (740)-283-3549 or Email customer.care@sunjoydirect.com for assistance.

Made in China