

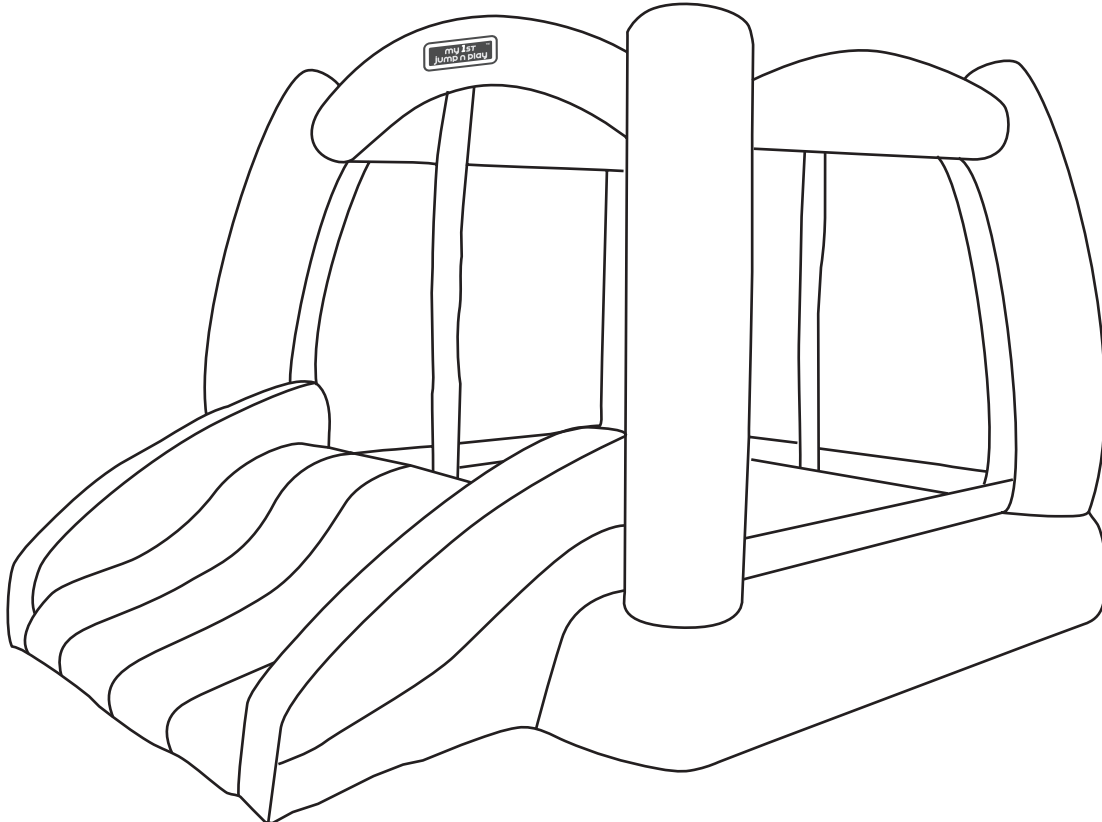

Assembly, Installation, Care, Maintenance and Use Instructions

My 1st Jump N Play

Model # INF-2037



CAUTION-ELECTRIC TOY - Not recommended for children under 3 years of age. As with all electrical products, precautions should be observed during handling and use to prevent electrical shock.

WARNING

- No more than 3 children should use the product at the same time.
- Combined weight of all users must not exceed 250lbs./113kg.
- Designed for children between the ages of 3 to 8.
- Mature adult supervision is required at all times during use.

DANGER

Warning-electrocution hazard do not use extension cord with this product. Electrically Operated Product. Do not use near water. Adult handling required. Do not allow children near the blower.

**For customer service or replacement parts, please call
1-866-370-2131 Monday through Friday 9am-5pm EST or visit our
website: www.sportspowerltd.net.**

RETAIN THIS MANUAL FOR FUTURE REFERENCE.

IMPORTANT SAFETY INSTRUCTIONS

WARNING

Carefully read and understand all of the instructions and safety warnings in this manual before assembling and using this product. It is the responsibility of the owner of this product to ensure that all users of this product are fully informed on the proper safe use and the inherent risks of playing on this product. Failure to do so can result in serious injury or death.

BEFORE YOU START TO ASSEMBLE...

- Check the package and make sure you have all of the parts listed in the Parts List section of this user manual. IF ANY PARTS ARE MISSING, please call the Customer Service toll-free number listed on the cover page for assistance. Do not return to the store.
- Do not install or use the product if any parts are missing or damaged. Store in a safe place until ready to install.
- Mature adult required to assemble and disassemble the product.
- Make sure that you have plenty of space and a clean dry area suitable for the assembly of this product. IT IS ESSENTIAL THAT THE INTENDED SITE FOR THIS PRODUCT IS COMPLETELY FLAT AND LEVEL. If the ground is uneven, this could cause movement in the product that could result in property damage and/or cause serious injury.
- Place the inflatable device on level ground, not less than 1.8m (6ft) in any direction from any structure or obstruction such as a fence, garage, house, overhanging branches, laundry lines, or electrical wires.
- Never modify the construction or the design of the product. Do not use any unauthorized Sportspower parts.
- Carefully check the product and the surroundings before and during each use. Make sure the anchors are securely in place and the product is fully inflated before allowing children to play.
- IMPORTANT: Save this manual for future reference.

IMPORTANT SAFETY INSTRUCTIONS

DANGER

- Adult supervision is required at all times. Restrict access when there is no adult supervision.
- No more than three children are allowed on the product at the same time. Combined weight of all users must not exceed 250lbs./113kg.
- Do not use the product in or around water. This is an electrically operated product and failure to follow these instructions could result in serious injury or death due to electric shock.
- Please ensure the openings of the enclosure netting are closed properly while children are bouncing inside the play house to avoid injuries from falling.
- Do not slide down the slide head first.
- Do not allow children to wrestle, flip or pile up on each other as this may result in serious injury. Separate the larger children from smaller children to avoid injuries while playing on the product.
- The blower is a high powered machinery and cause serious injury. Do not allow children to touch or be near the blower. Never direct stream of air from the blower towards the face or any other part of the body.
- This product is for household and family domestic use only – It is not for use in schools, playgrounds, rental or commercial use.
- Always consult your physician before performing any kind of physical activity.
- Do not use or leave the product outside during windy conditions. Do not use if the user or the product surface is wet. These conditions can cause the user to lose control and fall resulting in serious injury.

WARNING

- Always use the product in a well-lit area. Do not use without lighting during dawn, dusk or in complete darkness!
- The product must be placed on a surface that is **COMPLETELY FLAT AND LEVEL**. If the ground is uneven, this could cause movement in the product that could cause product damage and/or serious injury.
- **DO NOT** position this product on a hard surface such as concrete, tarmac or paving. Suitable surfaces are grass, sand or a play area covered with an appropriate depth of play bark material.
- Maintain clear space on all sides of the product.
- Areas immediately adjacent to all areas of access/egress of the inflatable device shall have use zones, which are free of obstacles and covered with impact attenuating surfacing for a minimum distance of at least 1.8 m (6ft).

IMPORTANT SAFETY INSTRUCTIONS

- Make sure that there are no hazardous objects above, below or near the product. Such objects include walls, fences, tree limbs/trunks, electrical power wiring, rocks, sprinkler heads or other recreational objects (i.e. swing sets, swimming pools). Children can be seriously injured by colliding with such obstacles.
- Adequate overhead clearance is essential. A minimum of 24 ft from ground level is recommended. Provide clearance for wires, tree limbs, and other possible hazards. The product must be stored away or disassembled completely during severe windy conditions.
- The product must be used with the anchors provided and installed properly.
- Do not use the product while holding or wearing any type of sharp or pointed objects such as jewelry, watches, rings, eyewear and necklaces before using this product.
- Do not wear loose fitting clothing that may catch or snag during play.
- No shoes or glasses are to be worn on the inflatable device.
- Always tie back long hair so that it does not block user's vision or get caught in the safety netting.
- Restrictions on the consumption of food, drink and gum.
- Do not attach items to the inflatable device that are not specifically designed for use with the inflatable device, such as, but not limited to, jump ropes, clothesline, pet leashes, cables and chain as they have the potential to cause a strangulation hazard.
- Do not allow pets in or around the product.
- Do not jump on the product with any play objects, including but not limited to, skateboard, roller blades or any other equipment. DO NOT hold any foreign objects not authorized by the manufacturer in your hand and DO NOT place any objects on the product while anyone is jumping on it. Please be aware of your surroundings to ensure there are no objects that could cause harm.
- Always keep hands and feet inside products during use.
- Children MUST NEVER be left unattended inside the enclosure at any time.
- The enclosure netting is ONLY intended to be used to reduce the risk of injury from falling off the product. Do not intentionally kick, bounce against, climb on, hang from or jump over the netting.
- Enter and exit the enclosure only through the enclosure door opening. Do not attempt to climb over the product.

CARE AND MAINTENANCE

- Inspect the product and blower carefully before each use, to ensure the anchors are fully secured and there are no tears or rips on the product.
- Do not use any chemicals or commercial cleaning products. Wipe clean with damp cloth.
- Product should be deflated, dried and stored immediately following use. Do not leave product exposed outdoors for extended periods as product will be damaged by external factors such as UV rays , rain and wind. In particular, do not leave outside during windy days.
- Make sure the product is fully dry before storing, and store only in a cool, well ventilated and dry location when not in use.
- Must be stored and kept out of reach of children and protected from pests or pets that can damage the product.
- Product must be fully inspected before and after each use. This is very important to ensure proper safety and maintenance of the product.

Blower Warnings

DANGER

- The product must be inflated with the blower provided. No unauthorized equipment or accessories should be used with this product.
- As with all electrical products, precaution should be observed during handling and use to prevent electrical shock. Electrical rating is 120V (AC Only), 60Hz, 3.8A, 450W.
- The blower is not intended for use or operation by children. Adult supervision is required.
- The blower should never be left unattended when in use.
- To prevent electrical shock, do not expose to water or rain. Never plug or unplug the blower with wet hands or while standing in water.
- Do not use extension cord with this product.

WARNING





- To reduce the risk of electrical shock, connect only to a ground type receptacle protected by a Class A Ground Fault Circuit-Interrupter (GFCI). Contact a qualified electrician if you cannot verify that the receptacle is protected by a GFCI.
- To reduce the risk of electrical shock, do not use the blower if the power line cord is damaged. The power cord cannot be replaced on its own; the blower must be replaced.
- To reduce risk of fire and electrical shock, do not use this blower with any other speed control device.
- Never move the blower when the power is on.
- All children must be off and away from the product before turning off the blower.
- Check the blower carefully to verify that the power cord and blower are not damaged and are away from water or debris.
- Do not clean the blower with any direct contact to water; instead use only a damp cloth.
- Do not immerse blower in water.
- ELECTRICAL SHOCK HAZARD: To reduce the risk of electrical shock, never use an extension cord to connect the blower. Plug the blower directly into a GFCI outlet in a secure area.
- Ensure ground around blower is clear of small objects that can be sucked into the blower.

Blower Warnings

- Gust of wind may lift blower off the ground.
- Always place the blower in a safe location away from traffic. Always avoid resting the unit in or near sand, small stones or other small objects that can be sucked into the blower and become hazardous.
- The blower and electrical cord should be kept out of reach of children.
- Power cord shall not pass under the air filled devise and interfere with its operation. All electrical supplies must be positioned outside of the accessible area and not within reach of children.
- Do not cover the cord with flammable material including carpet, or furniture or appliances. Place cord away from traffic area to avoid people tripping or the product tripping over.
- Check the blower before every use to ensure there is no damage to the blower before operating. Do not attempt to service the blower, particularly when it is plugged and any damages or weaknesses are found with the blower, the cord or plug, discard fan or return to an authorized service facility for repair.
- Store the blower in a dry and well-ventilated location.
- Regular check the intake and output opening and keep free and debris such as leaves, dirt, etc.

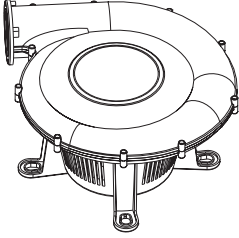
ELECTRICAL RATING: 120V (AC ONLY), 60Hz, 3.8A, 450W.

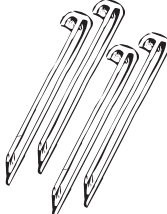
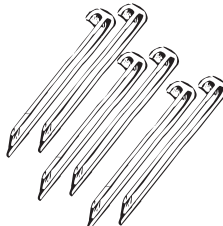
Parts List

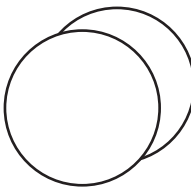
A	Blower		①
B	My 1st Jump N Play		①
C	Small Ground Stakes (for blower)		④
D	Large Ground Stakes (for product)		⑥
E	Storage Case		①
F	Repair Kits		②

Inflation & Staking

1. Remove the product from the storage case.

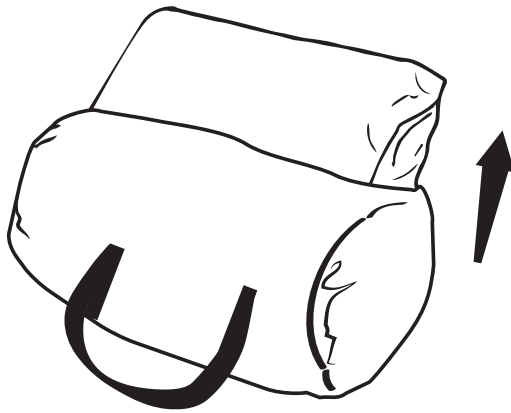

2. Unfold the product.



3. Tie the connector tube of the product to the blower.

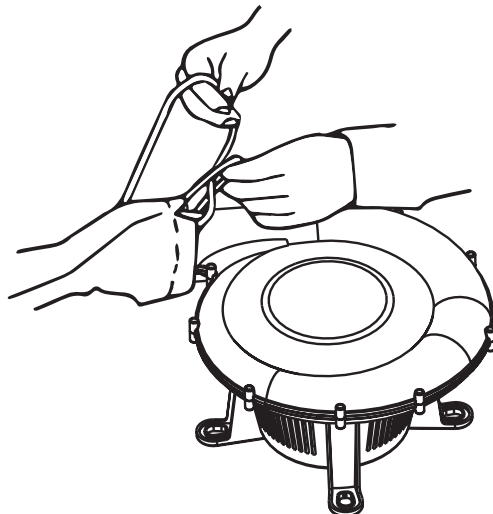

Inflation & Staking

4. Close the short tube as shown.

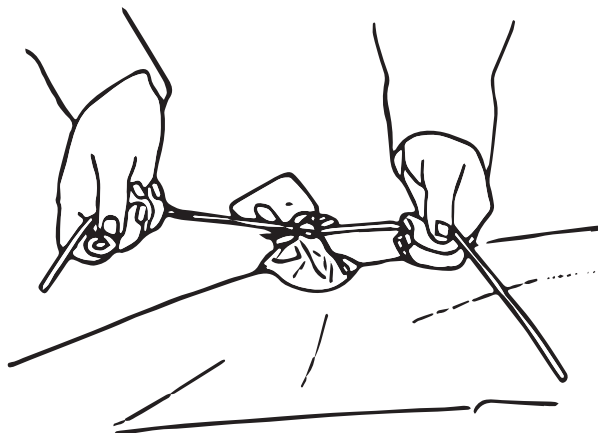

5. Secure the product and blower to the ground with the stakes provided.

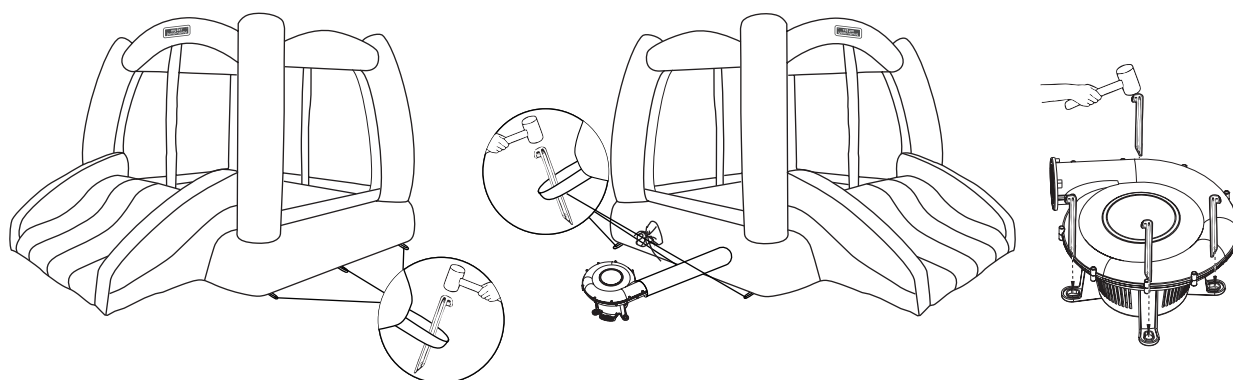

6. Switch blower power on. The product should inflate in approximately 2 minutes. Check for punctures if the product does not inflate properly.

IMPORTANT: Blower should remain on to keep the product inflated during use.

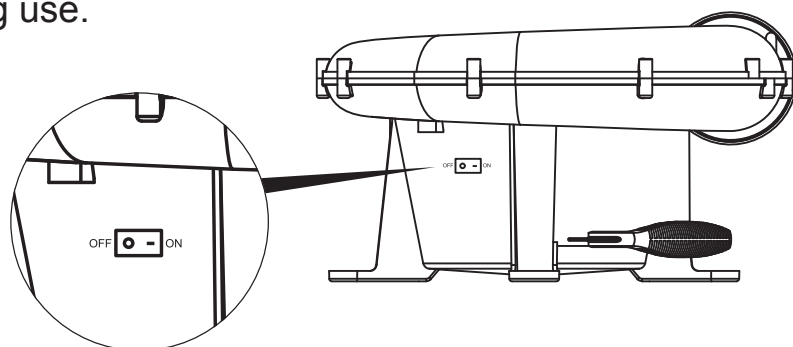

Deflation & Storage

1. Turn off the blower and unplug it from the outlet.

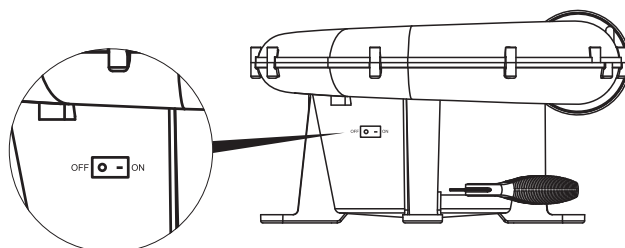

2. Remove the stakes from the ground, drawstring from the intake tube and allow the product to fully deflate.

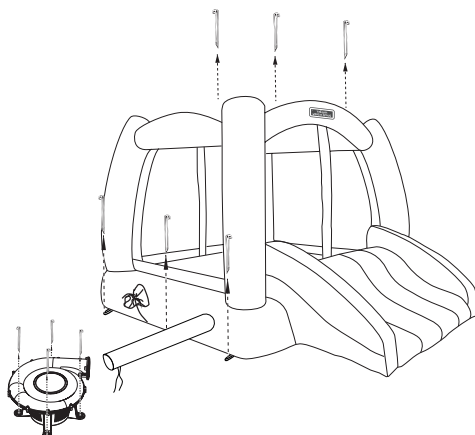

4. Fold the product. Product must be completely dry before putting away for storage. Starting at one end, roll to force air out. If air remains inside, gently press it to deflate the air.



5. Place into the storage case.

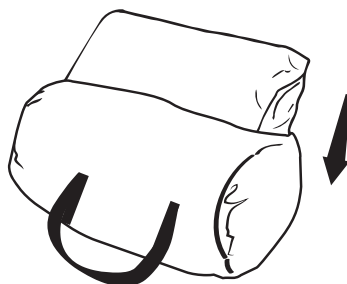

Repair Instructions

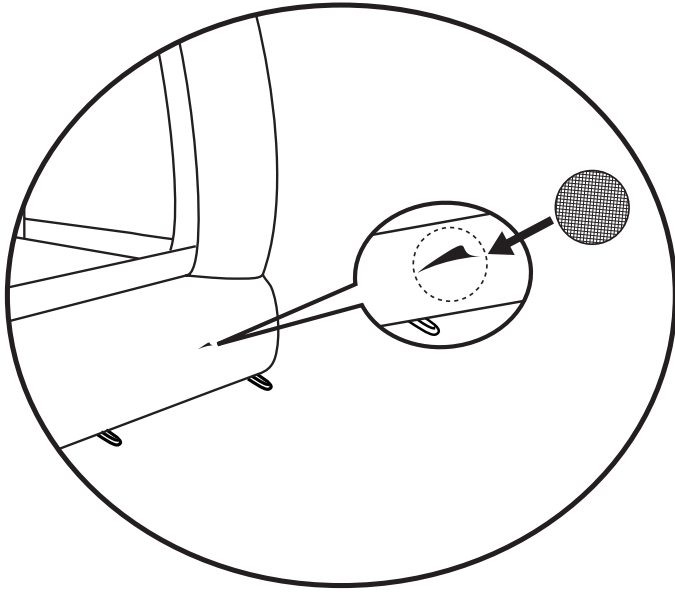

⚠ WARNING

Warning: Repairs must only be made by adult(s).

Keep repair kit away from children.

- Identify the location of the puncture or leak.
- Deflate the product and gently clean the damaged area with a damp cloth. Allow area to dry thoroughly.
- Remove the adhesive backing from the repair patch and place it over the damaged area (cut to size if necessary).
- Press the repair patch to remove any air bubbles.
- Wait 30 minutes to allow the patch to dry before re-inflating.

Warranty Information

Sportspower Ltd warrants its products to be free from defects in material and workmanship under normal use and service conditions for ninety (90) days after the date of purchase. Extended warranty from 90 to 180 days will be offered to those customers registering their products at www.sportspowerltd.net within 14 days from the date of purchase.

All warranty coverage extends only to the original purchaser of the product and is not assignable or transferable. The original store or online purchase receipt must be kept as proof of purchase in order for the warranty to be valid. These documents must be presented in the event of making a claim under warranty.

During the warranty period, Sportspower will provide repair or replacement of defective equipment or parts thereof covered by the warranty. Any handling, transportation, delivery and other incidental charges in respect of the servicing of the equipment shall be borne by the Purchaser. If the product includes a number of accessories, only the defective part or accessory will be replaced.

The warranty will become void if any defects or damages are associated with the use of unauthorized replacement parts. All replacement parts must be obtained from Sportspower authorized agents.

All decisions made by Sportspower in respect of the servicing of the equipment (including repairs, replacements or issues relating to defects of workmanship or materials) shall be conclusive and the Purchaser agrees to be bound by such decisions. Any defective equipment or part thereof replaced shall become the property of Sportspower.

In the event of a product or accessory being replaced during the guarantee, the guarantee on the replacement will expire at the original date, i.e. 90 days from the original purchase date.

This warranty excludes defects caused by the product not being used in accordance with instructions, accidental damage, misuse or being tampered with by unauthorized persons.

The sportspower limited warranty does not cover:

Products used for commercial or rental purposes.

Loss or damage to product due to: (i) abuse, repairs and/or tampering by any person other than the authorized personnel of sportspower; (ii) negligence and/or misuse (including foreign object, accident, improper storage, exposure to sun/moisture, excessive temperature, sand, dust, dirt, other pollution or other environmental conditions and failure to

Warranty Information

follow precautions or proper operating instructions stated in the user's manual such as improper installations); (iii) fire, flood, lightning strike, wind storm or other acts of god; (vi) freight or improper transport damages, and (v) improper usage (including use by under-age, over-weight or excessive number of users permitted as stated in the user's manual).

Defects, damages or accidents due to the malfunction, connection to or use of non-sportspower or unauthorized parts. In such event, sportspower reserves the right to cancel the limited warranty coverage immediately.

To the extent allowed by the applicable local law, the remedies in the limited warranty are the purchaser's sole and exclusive remedies.

Sportspower is not responsible or liable for indirect, special or consequential damages arising out of or in connection with the use or performance of the product or other damages with respect to any economic loss, loss of property, loss of revenue or profits, loss of enjoyment or use, cost of removal, installation or other consequential damages. Some states do not allow the exclusion or limitation of incidental or consequential damages. Accordingly, the above limitation may not apply to you.

The warranty extended hereunder is in lieu of all other warranties and any implied warranty of merchantability or fitness for a particular purpose is limited in its scope and duration to the terms set forth herein. Some states do not allow limitations on how long an implied warranty lasts. Accordingly, the above limitation may not apply to you. This warranty gives you specific legal rights. You may also have other rights which vary from state to state. This warranty is valid only in the united states.

DO NOT RETURN TO THE STORE.

For customer service, please call 1-866-370-2131 Monday-Friday 9:00am-5:00pm Eastern Time. If you cannot reach us at the above number for any reason, please visit www.sportspowerltd.net.

Sportspower Ltd - Flat M, 3/F, Kaiser Estate Phase 3, 11 Hok Yuen Street, Hunghom, Kowloon, Hong Kong