

Owner's Manual



Evaporative Air Conditioning Installation Instructions

For help with installation or warranty issues call

1-800-939-2983 or www.bonaire-usa.com

For parts Visit our secure website www.bonairedurango.com

This product may qualify for rebates*

*Check with your local agency

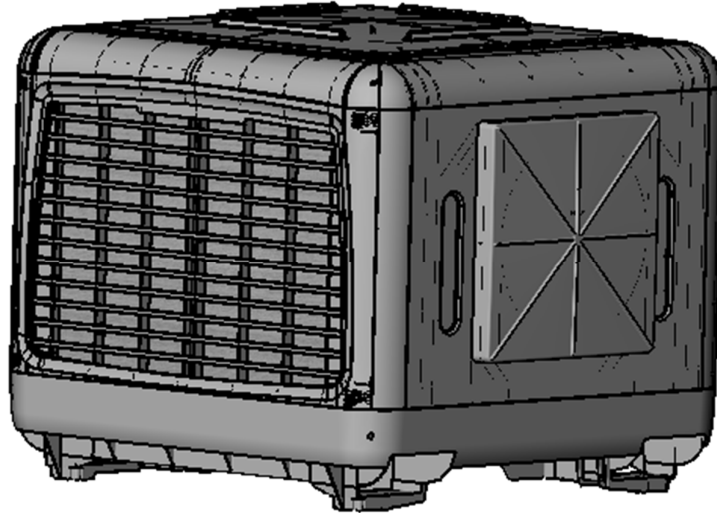

Please keep this important manual in a safe place. It is the owner's responsibility to ensure that regular maintenance is carried out on this evaporative cooling product. Failure to do so will void all guarantees beyond statutory and legal requirements.

Contents

INTRODUCTION.....3

UNIT LOCATION.....6

UNIT INSTALLATION.....7

UNIT INSTALLATION (SIDE DISCHARGE).....12

CHECK LIST.....20

PROBLEM SOLVING.....21

PARTS LIST.....22

MAINTENANCE.....25

WARRANTY.....26

SERVICE.....28

1.0 Introduction

General Information

Thank you for purchasing a quality Bonaire Evaporative Cooler. We care about your safety and would ask you to spend a few minutes reading these simple instructions before operating this product.

Safety!



Read carefully all of these instructions prior to operating the unit.

- **Read and Save these Instructions. Do not throw these Instructions away.**
- Interference with and operation of this cooler in any manner not prescribed by these instructions could cause a safety issue and **WILL** void any warranty.
- Do not use cooler on uneven or unstable surfaces.
- Electrical connections should only be performed by a qualified electrician to ensure that all wiring will confirm to your local standards.
- Use only with a 110V / 120V, 60Hz, 1 phase electrical supply.
- Motor and pump have a grounded, molded plug and an automatic thermal overload which will stop the motor operation if it overheats. The motor will restart again when it cools down.
- The molded pump receptacle is for the grounded evaporative cooler pump only. Do not plug anything else into this receptacle.
- Do not alter or modify this cooler.
- Do not allow children to operate or service this cooler.
- **WARNING:** To reduce the risk of fire or electric shock, do not use this product with any solid state speed control device.
- Use only qualified electricians for replacement or servicing of switches, or electrical motors and components in this cooler.
- Always turn off power and unplug the fan motor and pump inside the cooler before installation or maintenance.

1.0 Introduction

Evaporative Cooling

The principal of your unit is to introduce fresh air, which is washed through the filter pads to provide cool fresh air. The air is exhausted taking with it any heat loading on the home.

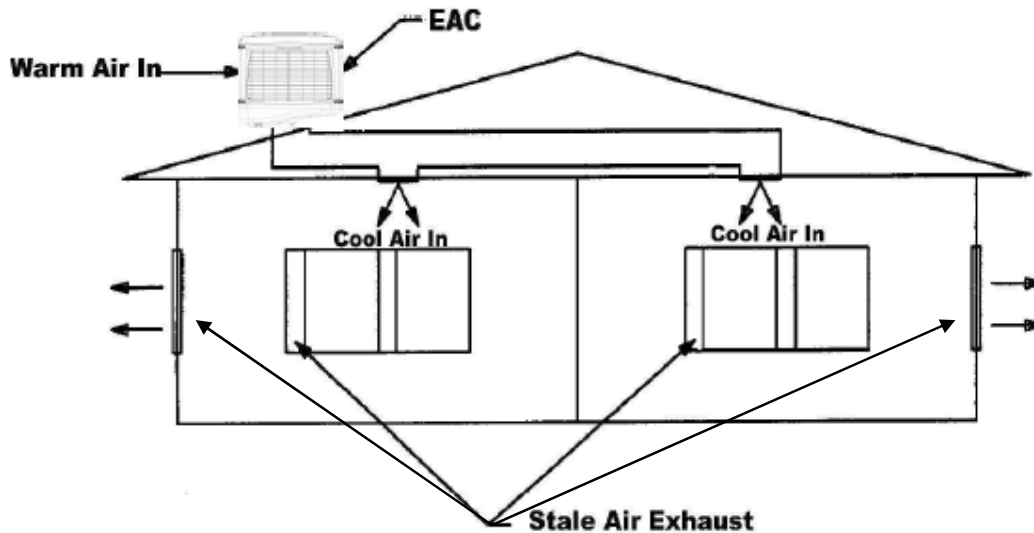

Exhaust

It is essential for successful operation of evaporative air-conditioning that there are sufficient exhaust openings in the area to be ventilated. Open doors and windows will usually provide this.

The minimum exhaust opening should be 10 ft² for the 5,000 cfm unit and 14 ft² for the 7,000 cfm unit.

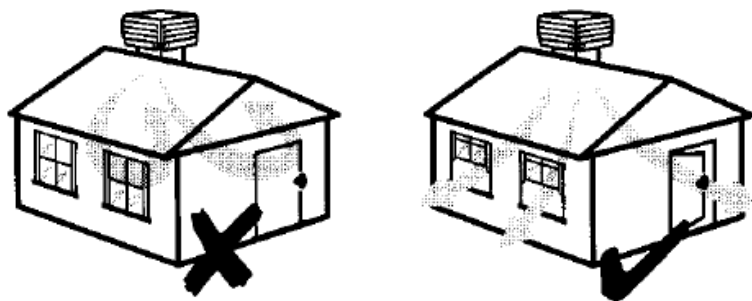

Vent Area for Doors and Windows



5½ ft²



16 ft²

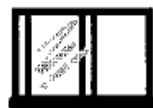

8 ft²



5½ ft²

1.0 Introduction

FAILURE TO COMPLY WITH THESE INSTRUCTIONS:

If this product is installed in a manner which is inconsistent with these installation instructions or, if the product has been modified and or altered from its original form, we shall not be held in any way liable to the purchaser of the product or any other person in connection with any loss or damage that have may have been, or may in the future be, suffered or incurred as a result of such incorrect installation or modification or alteration of the product.

Should you not follow these instructions the unit warranty may be void. The cost of warranty would then be a cost to the customer or the installer / dealer.

Refer to the tick box Commissioning Checklist to ensure you have covered all points when the installation is complete.

1.1 Important Notes

- **TEXT AND ILLUSTRATION COPYRIGHT CLIMATE TECHNOLOGIES Pty Ltd. 2016**
- All rights reserved. No part of this document may be reproduced or transmitted in any form or by any means, electronic or mechanical, including photocopying, recording or by any information storage and retrieval system, without prior permission in writing from Climate Technologies.
- Climate Technologies is constantly researching and developing improved product features and therefore reserves the right to change the specifications without notice. E. & O.E.

1.2 Before Commencing

- Packaging – check there is no damage before removing packaging. Damaged units should not be installed. Bonaire Customer Care Line should be contacted prior to installation. Careless transportation by installer will not be covered by warranty.
- Do not install damaged products. Contact the Bonaire Customer Care Line for further advice.
- **Installed damaged products will not be covered by warranty.**
- Have you got all the system components?
- Have you got the right unit?
- Does the system design conform to the minimum specification of the sizing specification and as such fall in line with sound engineering design practices?

2.0 Unit location

2.1 Unit Location Check List

- **EPA** - A correctly installed unit will perform to specification on sound pressure radiated noise. As an installer, you have a professional obligation to ensure that every practical and reasonable effort is made to install this product to best practice guidelines and ensure that any operational noise does not affect neighbours. Complying with EPA / council by laws for noise abatement is the responsibility of the dealer / installer / owner.

NOTE: Do not mount the unit on a section of roof that slopes towards a neighbour's property.

- Place the unit well away from sources of smoke, dust and objectionable fumes so that only clean, fresh outside air will be drawn into the unit. Reference should be made to relevant electric codes and state plumbing regulations.
- Check the proposed location to ensure that building members are structurally capable of supporting the operating weight of the air conditioner. You may need to consult the roof truss manufacturer.
- The unit must be installed in a position that gives safe access for service. It is the responsibility of the dealer / installer to ensure safe access to the unit can be obtained for servicing the product.
- Where roof height, pitch or construction will cause OH&S concerns as previously mentioned, service footing supports / platform and or harness anchorage must be provided for safe service.

NOTE: The manufacturer and its service providers reserve the right to refuse service unless safety and accessibility to the unit can be guaranteed.

- The providing of any extra equipment required to give access to the unit for servicing or warranty repairs is the responsibility of the owner.

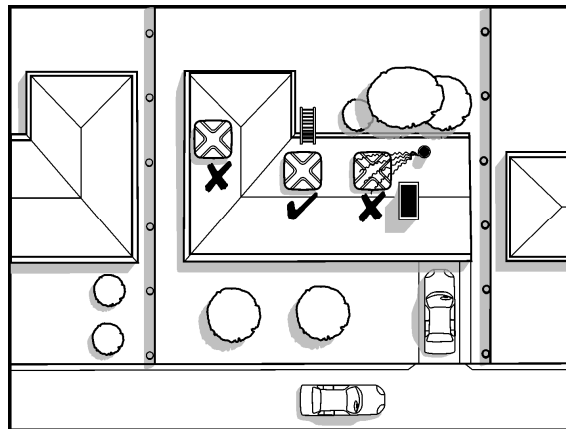

The unit should face into the customer's back yard, as low as possible on the roof, with easy, unobstructed access. Keep the unit away from chimneys, flues and vents that will pollute the filter pads and the fresh air being drawn into the house.

Unit Installation

3.1 Down Discharge installation

The evaporative cooler will be delivered with the fan motor assembly installed in “down discharge” mode. See the image below.

The air will be directed downwards when installed in this configuration.

NOTE: This cooler is suitable for use with 17 $\frac{3}{4}$ ” and 19 $\frac{3}{4}$ ” duct sizes.

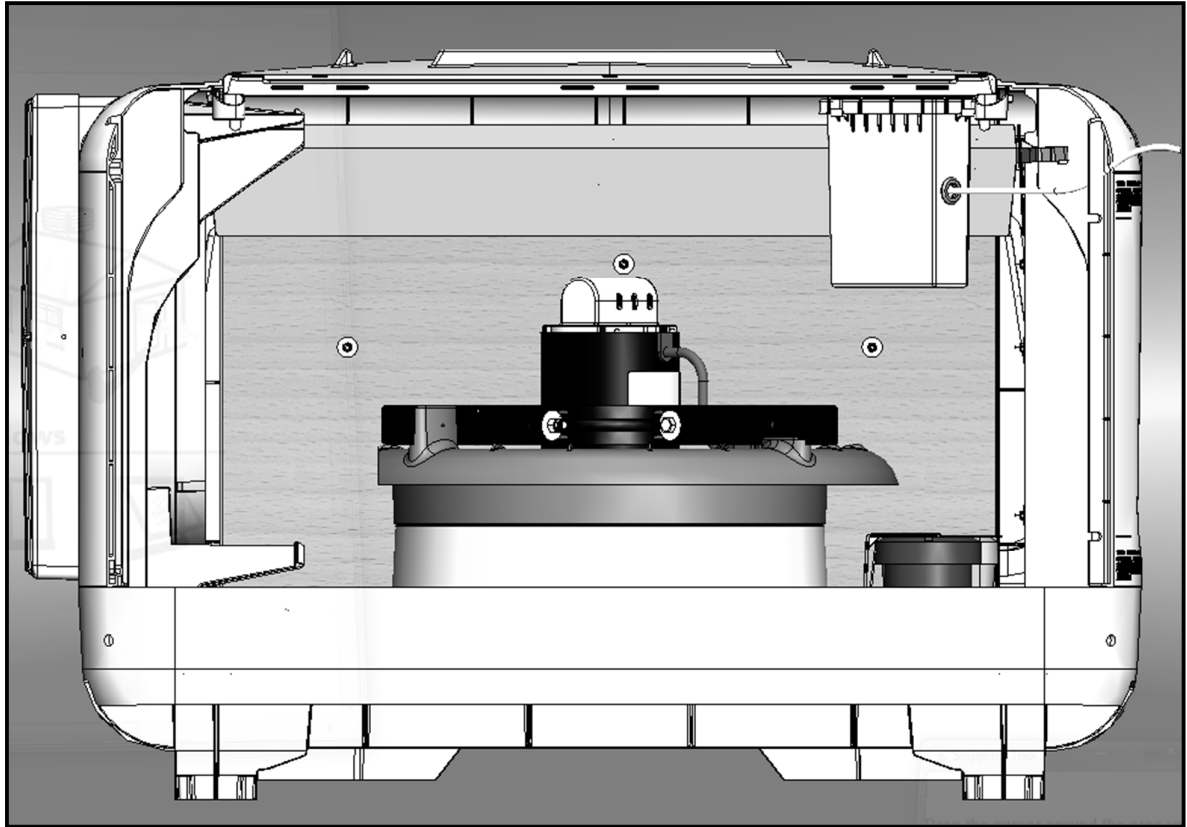

Down discharge configuration

Unit Installation

3.2 Electrical connections

3.2.1. Unscrew the thumb screws (transit screw) from the top of the louvres

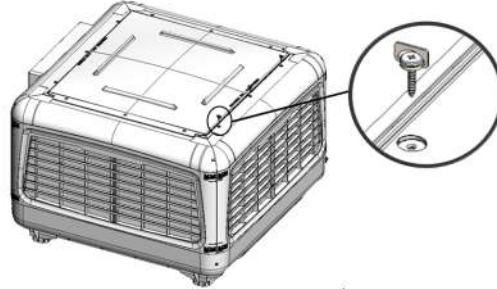

3.2.2. Slide the removable louvre upward and remove from the unit.

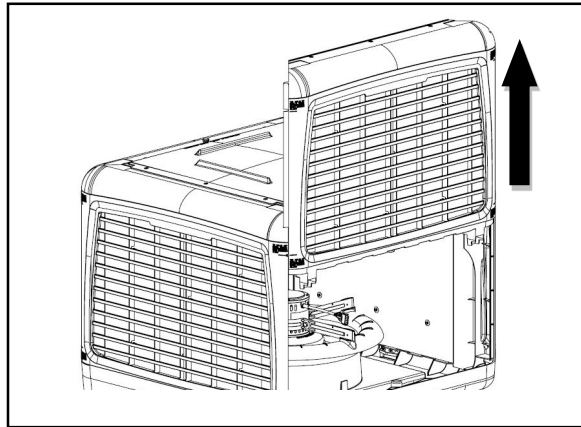

3.2.3. To fit the electrical supply cable utilise the 7/8" hole in the louvre.
See image below for location (as viewed from rear of louvre).

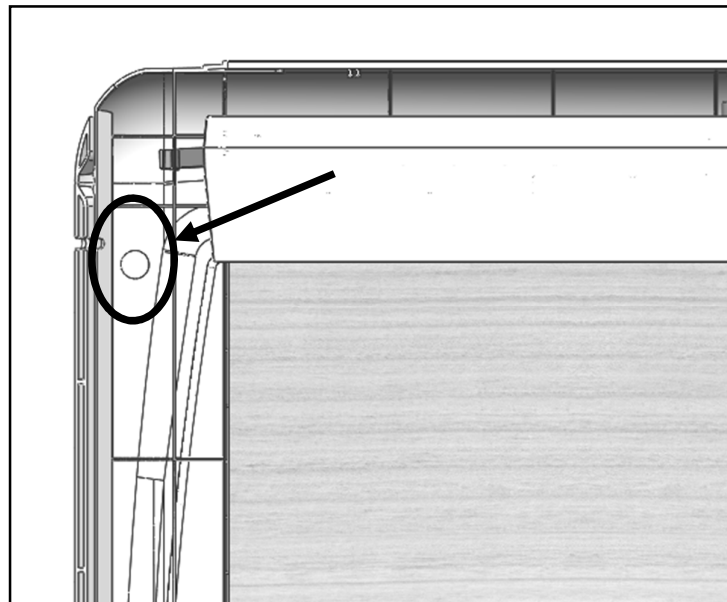

Unit Installation

- 3.2.4. Remove the control box to access the fan motor and pump wiring harness to allow connection of the wiring.

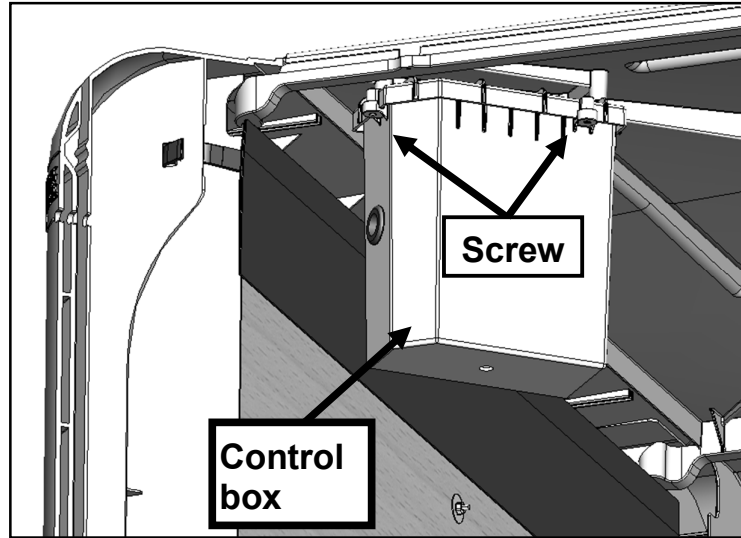

- 3.2.5. Connect the wiring as shown in the diagram below

WARNING:- Electrical connections should be performed by a qualified electrician so that all electrical wiring conforms to local standards.

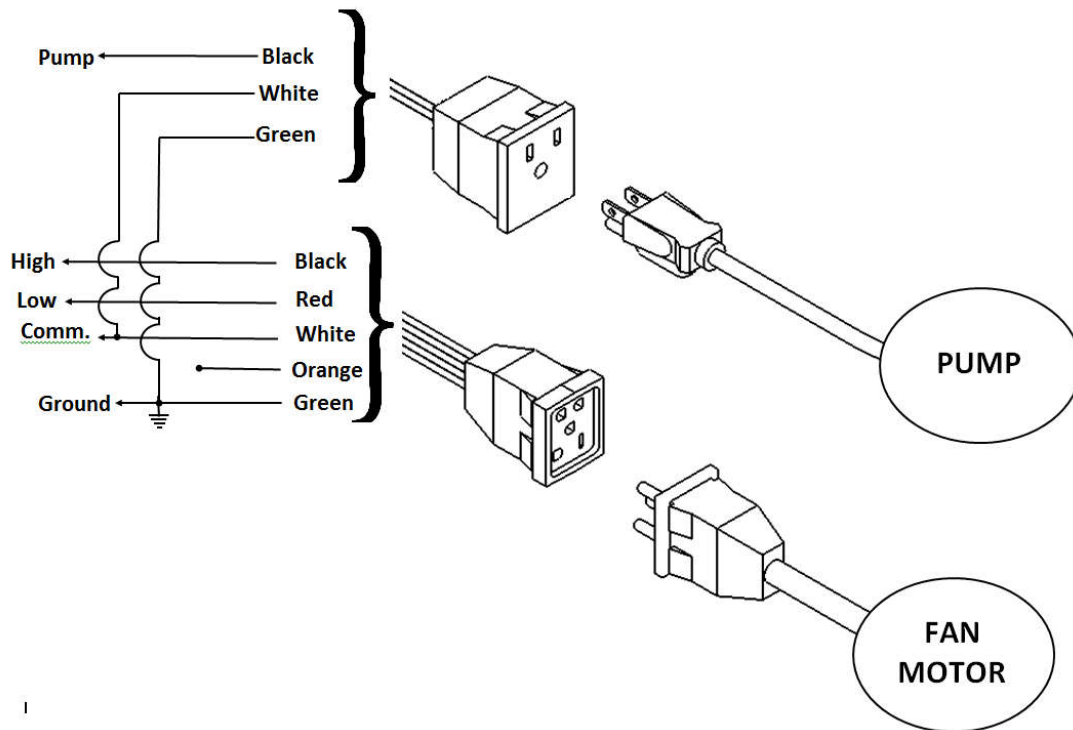

Unit Installation

3.3 Water connections

3.3.1 Connect the Float valve to the water supply. Note the float valve and connections have been factory fitted requiring only water supply hose to be fitted to the external connection fitting at the corner of the tank /base as shown in the image below.

Ensure all water connections are securely fastened to prevent leaks

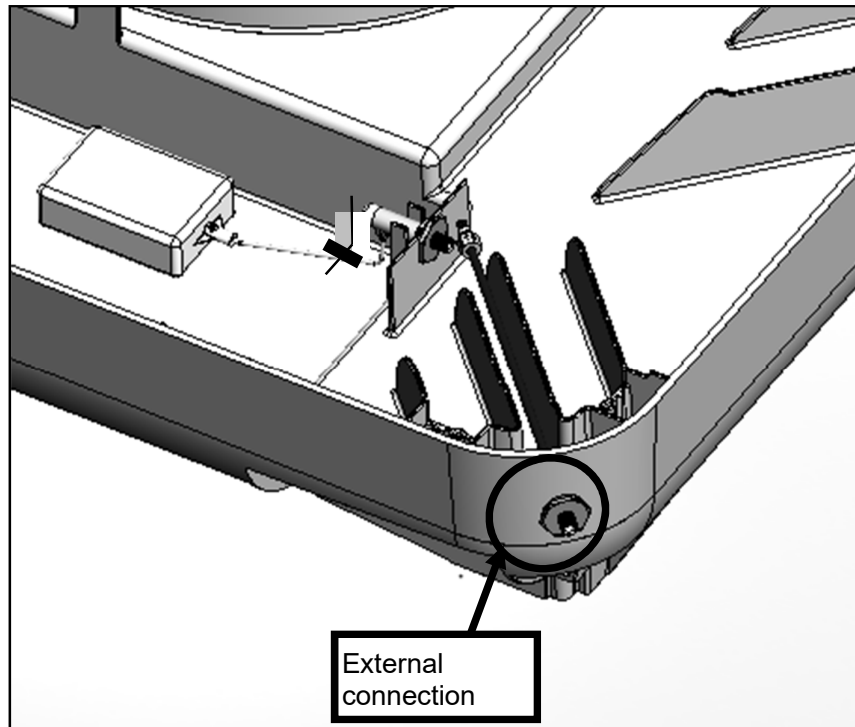
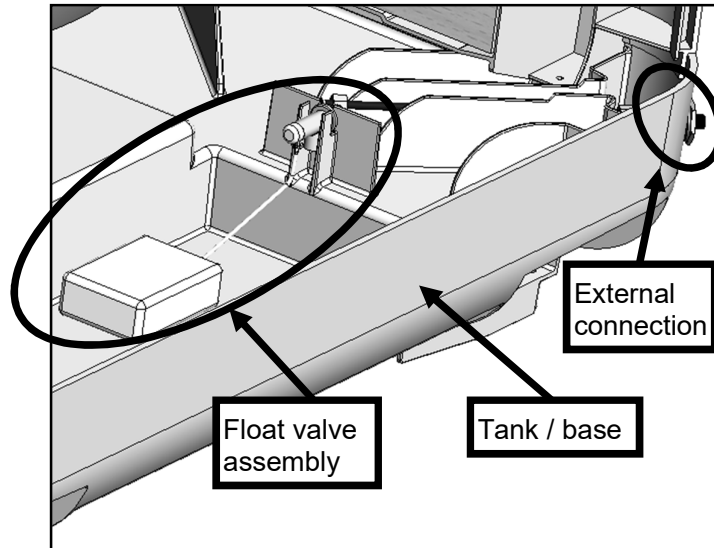

Unit Installation

3.3.2 Installation of the bleed off hose is required to prevent mineral deposits in the system. Adjust the bleed restrictor bracket to allow control of the bleed rate to suit local supply water conditions. Adjust the bleed off to approximately 2 ½ gallons / hour and adjust as necessary.



Ensure the cooler is level

Adjust the mounting legs if necessary

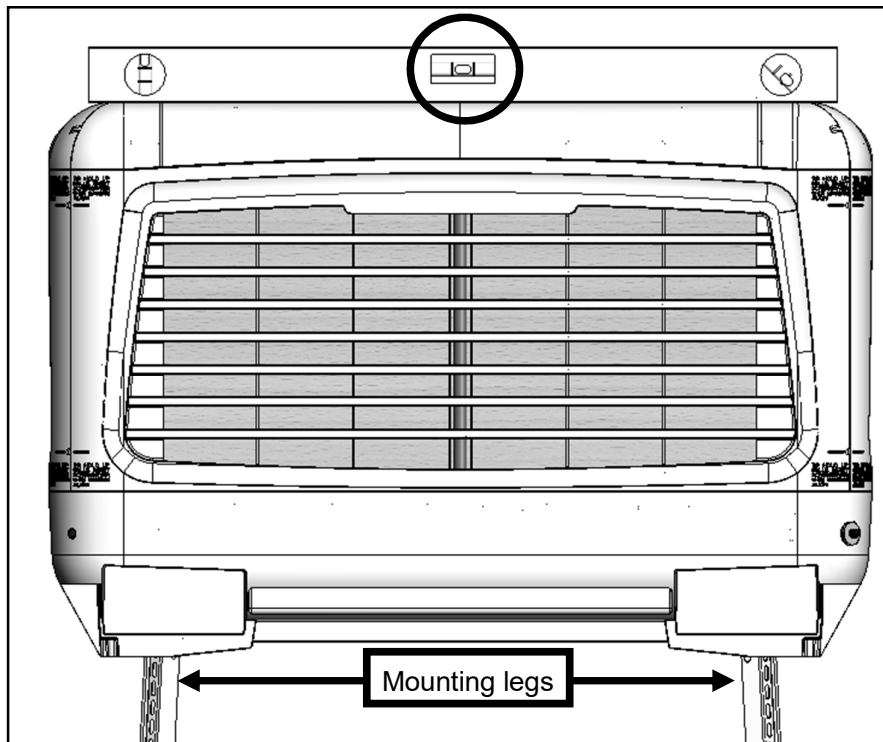

Turn the water on to the unit and allow the unit to fill.

- Check water fittings do not leak
- Ensure float valve operates.
- Fit the louvre panels and check for even wetting of the filter pads
- Check bleed off rate.

Unit Installation

3.4 Converting from Down Discharge to Side Discharge Installation

NOTE: Handle the fan/venturi assembly with care, as the fan blade is not protected by the venturi once removed.

The evaporative cooler has been designed to allow for the discharge configuration to be changed to “side discharge” mode.

The air will be directed to the side in this configuration.

- a. Always turn off power and unplug the fan motor and pump inside the cooler before installation or maintenance.
- b. Remove the 2 screws from the each side of the cap to allow removal
- c. Remove and retain the cap

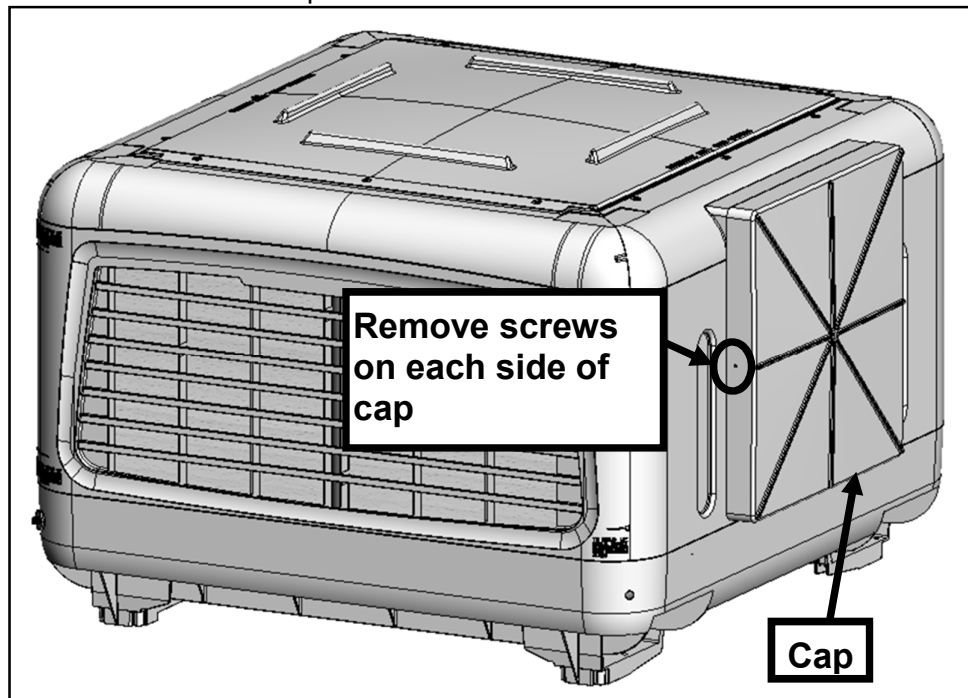

- d. Remove the lid screws and then remove the louvre on the opposite side of the side discharge louvre

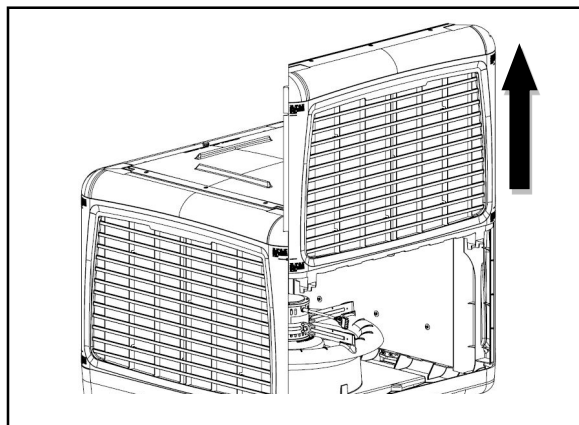

Unit Installation

- e. Disconnect the motor and pump cables from control box plugs

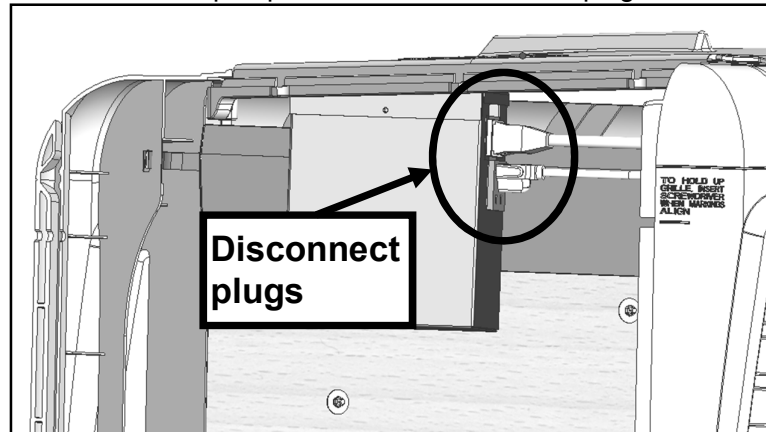

- f. Slide the lid out (be careful as the control box is attached to the underside of the lid) of the louvre assemblies. Leave the side discharge panel in place

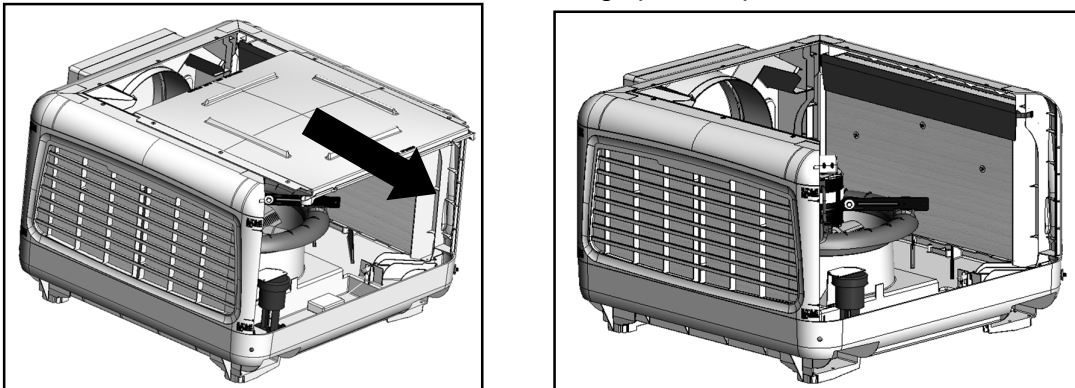

- g. Carefully lift the fan from the down discharge position

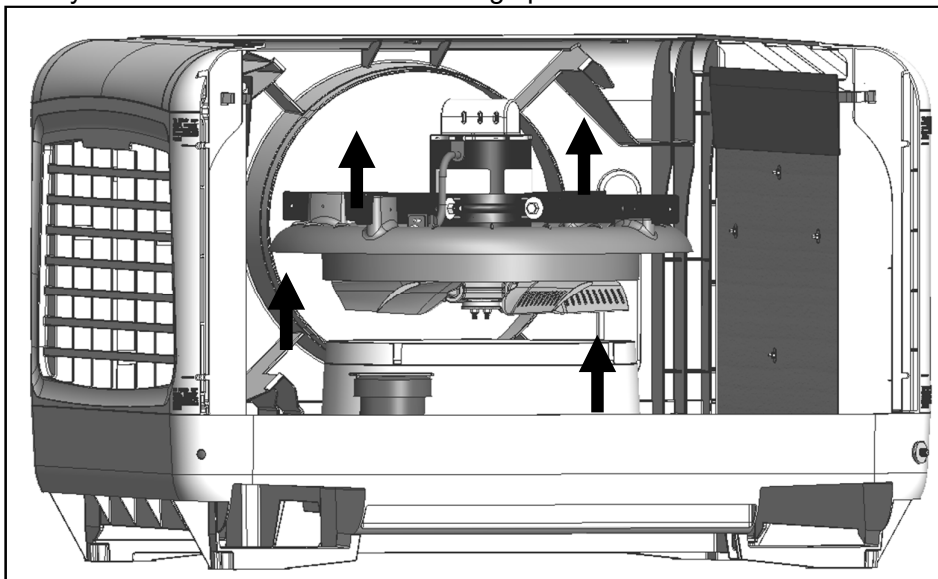

Unit Installation

- h. Remove and retain the 2 screws that fasten the side discharge panel.

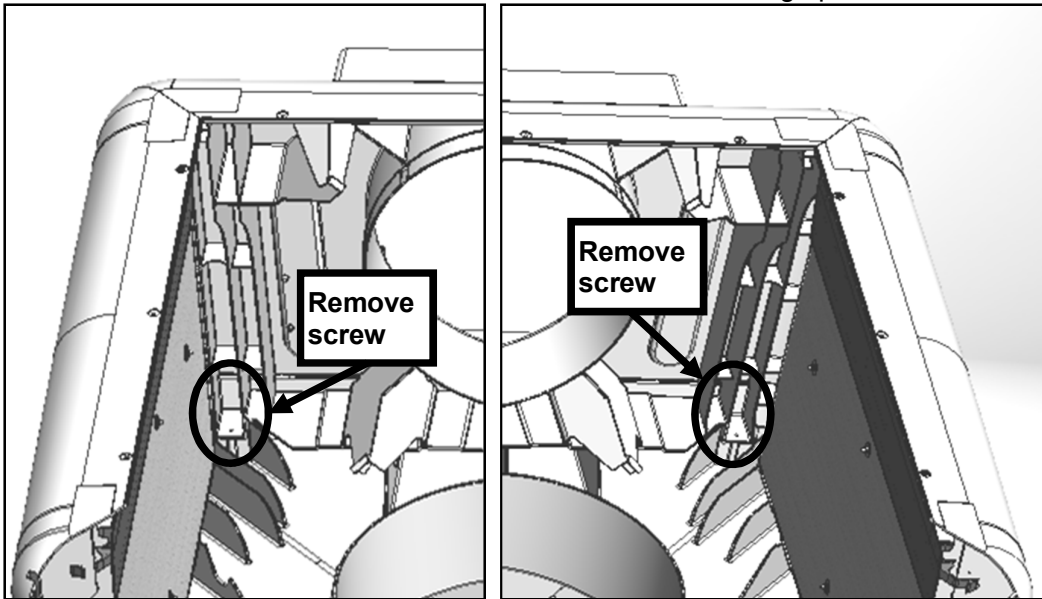

- i. With the retaining screws removed, lift the side discharge panel.

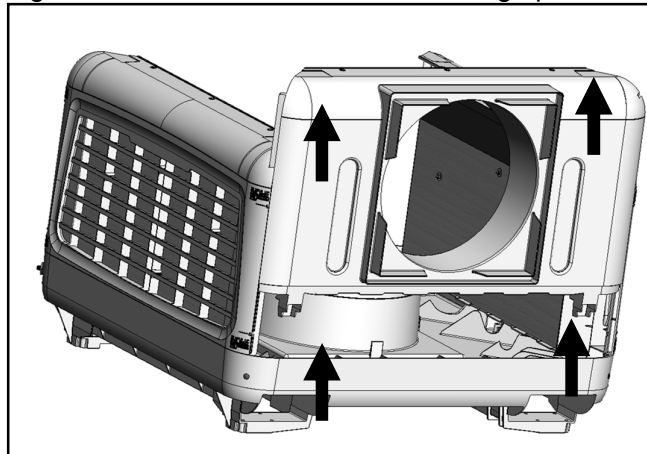

- j. Lay the side discharge panel down onto a surface that will not damage the panel.

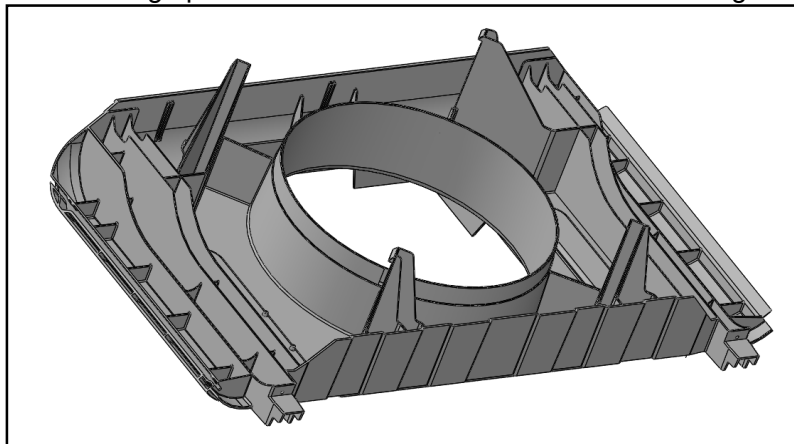

Unit Installation

- k. Present the fan motor assembly to the side panel ensuring the flat section of the venturi is at the top, aligned with the top of the panel.

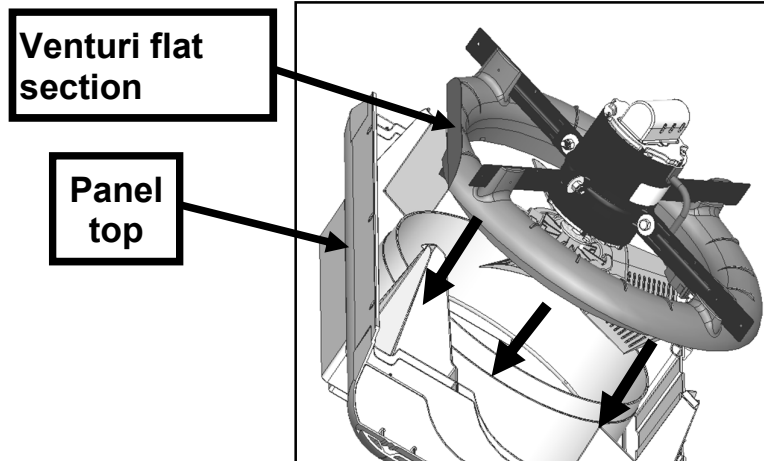

- l. Carefully introduce the fan motor assembly to the side panel.
NOTE: to fit the fan motor assy the motor arm support of the side panel will need to be carefully flexed to get the motor arms in the correct positions. (4 places)

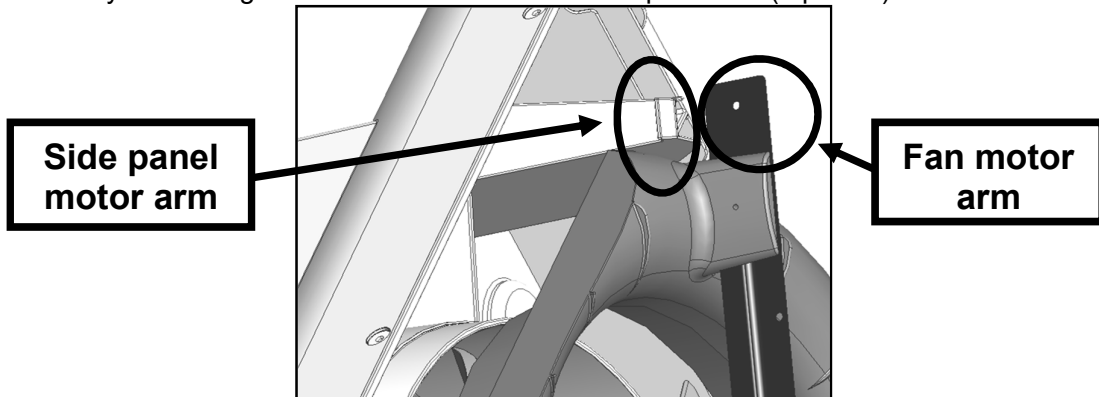

- m. Ensure motor arms are securely located by the "hooks" on the side panel motor arm supports (4 places)
NOTE: Fan motor arms are on the "hook" side of the side panel motor arm support (4 places) as shown in the image below

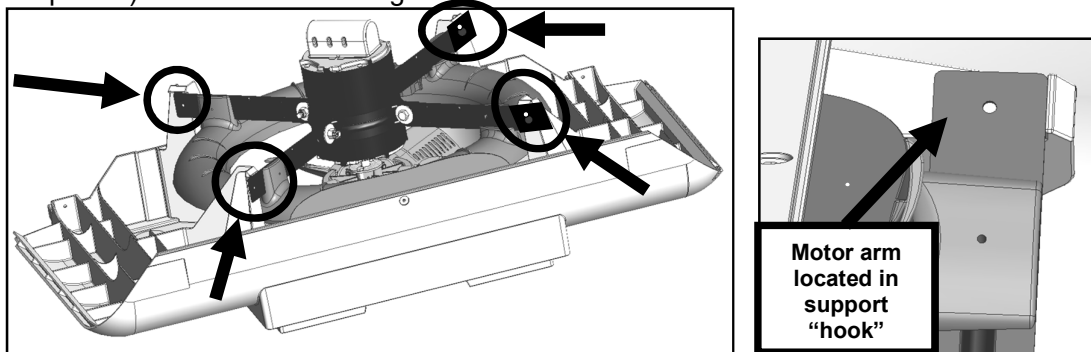

Unit Installation

- n. Refit the side panel and fan motor assembly to the base / tank.

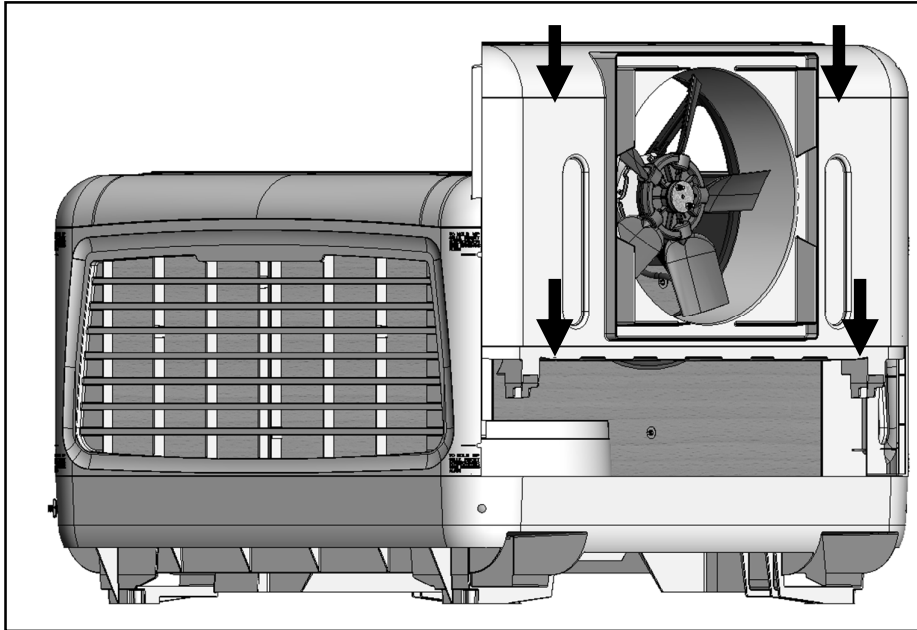

- o. Refit side discharge panel screws (2 places) to secure panel to base / tank.

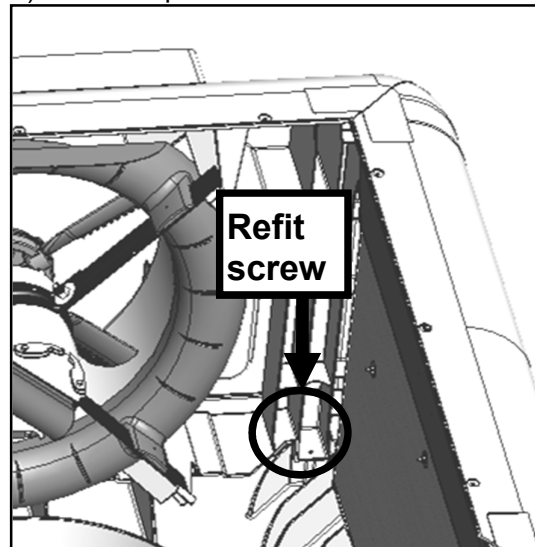
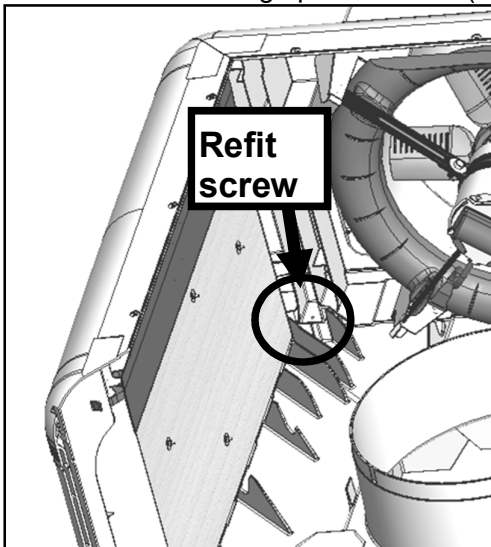

Unit Installation

- p. Fit the cap to the “down discharge” opening by aligning the 4 projections on cap with the 4 notches on the “down discharge” opening so the cap fits squarely in the base.

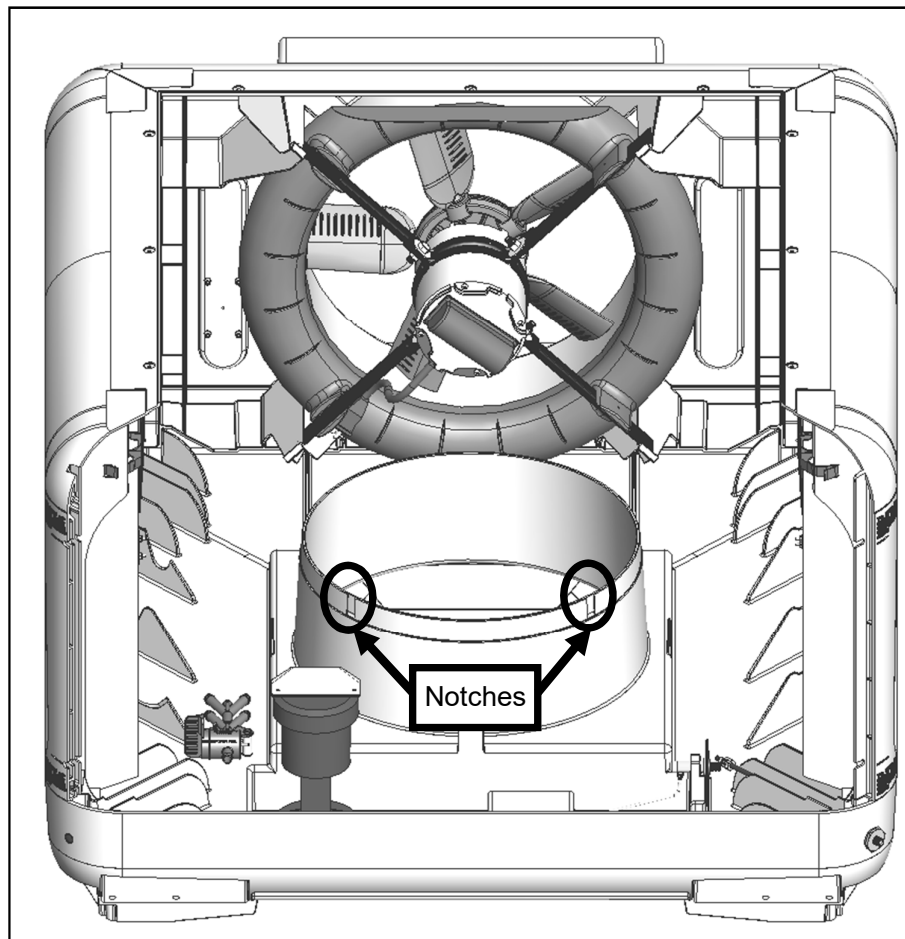
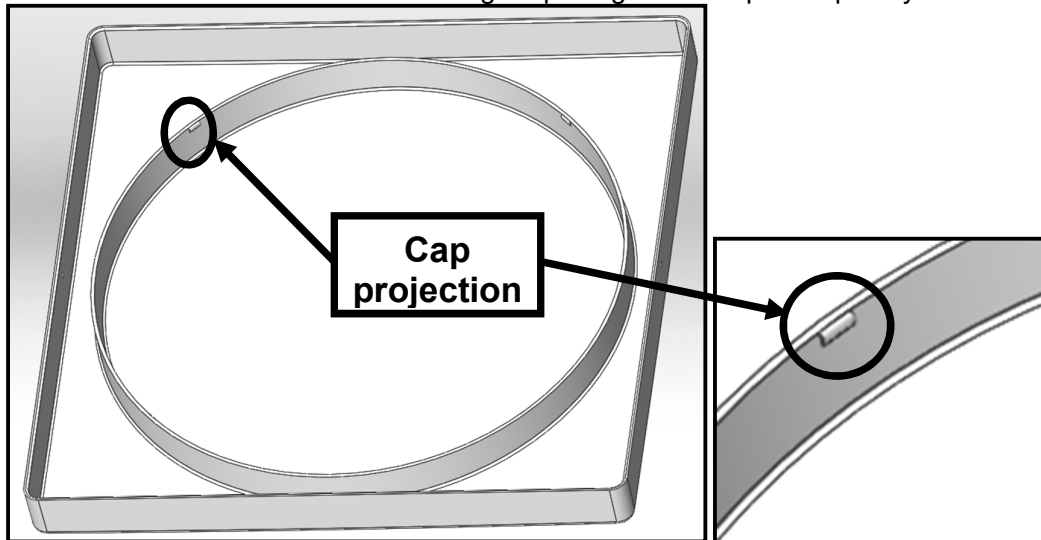

Unit Installation

- q. The cap should fit squarely on the base as shown in the image below.

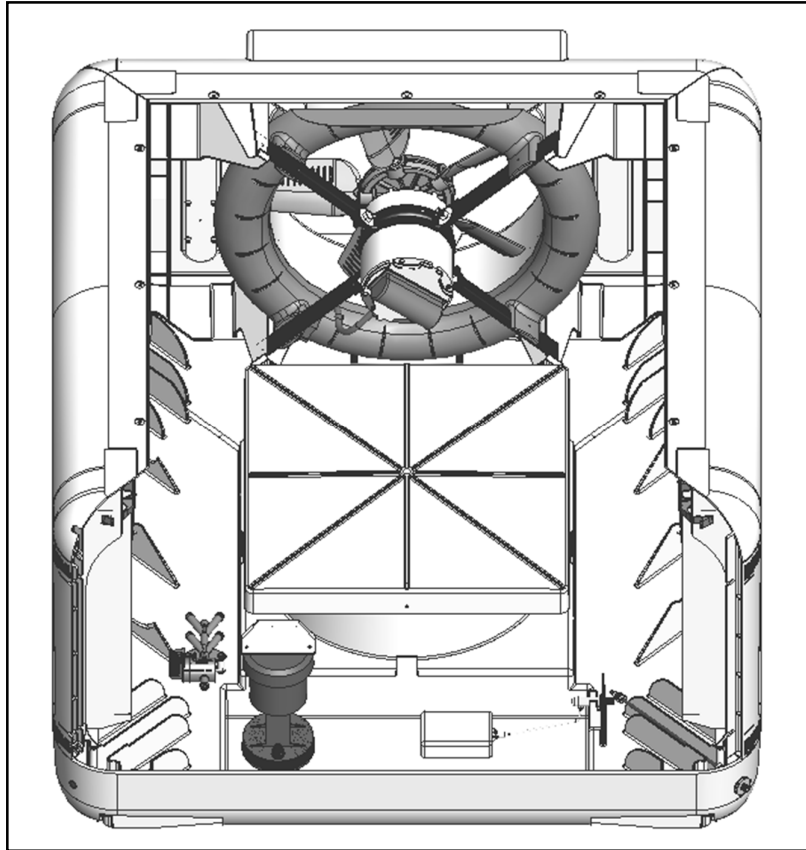

- r. Slide the lid back into place.

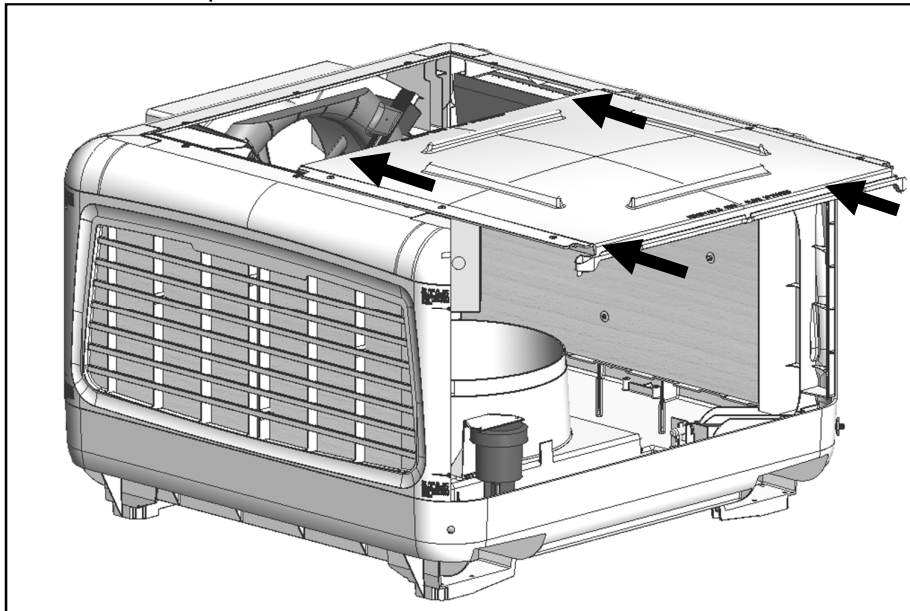

Unit Installation

- s. Reconnect the motor and pump cables to control box plugs.

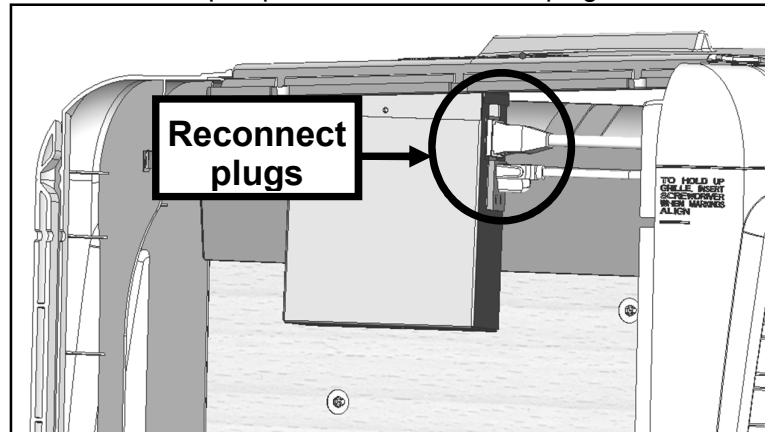

- t. Refer section 3.2.5 regarding wiring to electrical supply.

WARNING: - Electrical connections should be performed by a qualified electrician so that all electrical wiring conforms to local standards.

- u. If water fittings have not yet been connected, refer to section 3.3
v. If Electrical and water connections are complete, refit grille and screws (transit screw) in the top of the louvres.

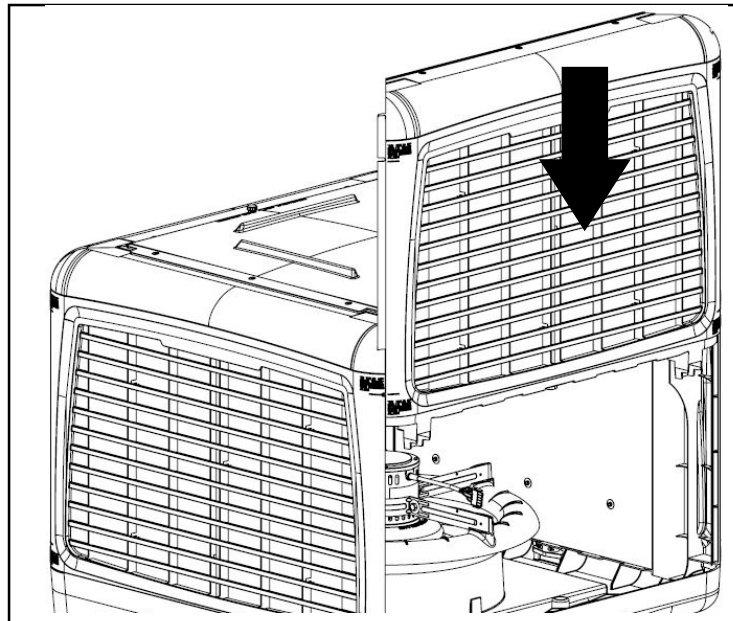

Check list

Check List

Use this list to check the installation.

Unit

- All equipment ordered by the customer is installed.
- The unit is level and secure.
- The water supply line has been flushed to clear swarf and debris and is free of leaks.
- The tank is free of foreign matter and debris. The water isolating tap is turned ON.
- Water drainpipe work is completed and sealed.
- The fan assembly is correctly located and the fan blade spins freely in the venturi.
- The mains and control wiring are complete and the circuit breaker is turned ON.
- The water basin fills with water and the float valve closes correctly when the water level is below the overflow level.
- The water pump operates correctly when turned ON at the controller.
- Bleed rate is set to suit local water conditions.
- The fan operates through the entire speed range.
- Water distribution is even with the filter pads fitted and the air conditioner operating pump and fan.
- All Controller functions for the appliance operate

Ductwork and general

- All roof penetrations are fully sealed and watertight.
- All ductwork is completed to plan, correctly supported and airtight, with no bend tighter than 1.5 x the ductwork diameter.
- Air distribution checked, dampers are adjusted and all outlets correctly adjusted and wiped clean.
- Man hole cover replaced.

Problem Solving

Problem Solving

PROBLEM	PROBABLE CAUSE	REMEDY
Unit fails to start	<ul style="list-style-type: none"> a. Power Failure b. Tripped Circuit Breaker c. Blown Fuse d. Electrical Fault in cooler 	<ul style="list-style-type: none"> a. Wait for power to be turned on. b. Reset circuit breaker c. Replace d. Call Bonaire Care Line
Filter Pads not wetting.	<ul style="list-style-type: none"> a. Pump Seized b. Electrical fault with pump 	<ul style="list-style-type: none"> a. Extension cord dropping voltage b. Maintenance page. See Pump section. c. Adjust restrictor d. Call Bonaire Care Line
Filter pads too wet	<ul style="list-style-type: none"> a. No water restrictor b. Electrical fault with pump c. Needs smaller restrictor d. High voltage in your area 	<ul style="list-style-type: none"> a. Maintenance page. See Pump section. b. Adjust restrictor c. Call Bonaire Care Line
Water leaking from overflow	<ul style="list-style-type: none"> a. Float Valve Leaking b. Drain from Pads 	<ul style="list-style-type: none"> a. Adjust or replace float valve if necessary b. Normal Operation – adjust float level
Water Droplets in air stream	<ul style="list-style-type: none"> a. Loose Delivery Tube b. Break in tubing c. Pump appears to deliver excessive water to pads d. Bleed nozzle is blocked 	<ul style="list-style-type: none"> a. Check and tighten b. Replace as necessary c. Check the condition of the filter pad. Wash if pad shows heavy build-up of minerals d. Clean bleed nozzle
Excessive humidity	<ul style="list-style-type: none"> a. Not enough air flow b. Inadequate Exhaust 	<ul style="list-style-type: none"> a. Increase fan speed b. Provide more open area to exhaust stale air by opening windows and doors in adjacent rooms.
Inadequate Cooling	<ul style="list-style-type: none"> a. Dirty Filters b. Dry Filters 	<ul style="list-style-type: none"> a. Clean b. Check control set on COOL mode. Check water delivery system. Adjust if necessary.
Unpleasant Odor	<ul style="list-style-type: none"> a. Unit located near odor source b. Algae in water tank 	<ul style="list-style-type: none"> a. Remove source b. Clean tank and refill with fresh water.
Rapid formation of white deposits on pads	<ul style="list-style-type: none"> a. Insufficient bleed rate b. High mineral content in water supply 	<ul style="list-style-type: none"> a. Bleed off should be checked to see if bleed nozzle is blocked, clear if necessary and clean pad. b. Increase the bleed rate. More regular maintenance may be required.

ANY FURTHER PROBLEMS PLEASE CONTACT YOUR
BONAIRE CUSTOMER CARE LINE ON 1-800-939-2983

Parts list

Replacement Parts List – 7000cfm

Component	Item Description
0121913	CABLE TIE 3502ORT18R/WOR CT95M
0141243	NUT 3/8 UNC NYLOC Z/P
0141435	SCREW-10x20 Hi-Lo HEX WASH S/S
0141435	SCREW-10x20 Hi-Lo HEX WASH S/S
0141479	THUMB SCREW SBB - SS
0141909	BOLT-3/8X1" ZP
0142331	WASHER 3/8X1-1/4X16G Z/P
6051313	NUT- RETAINING MKII
6080101PG	TANK CP2 PIGEON GREY
6080102PG	LID CP2 PIGEON GREY
6080108	WATER DISTRIBUTER SLOPE ASSEM
6080114	CAP SD/DD P GREY 425D
6080118	VENTURI 425mm
6080119	FAN 425mm 20DEGREE PITCH
6080122	MTG BRACKET UL DIAL PUMP
6080161	FILTERCOOL CP2 LGE 800x600x75
6080221PG	GRILLE CP2 SIDE DISCH PIG GREY
6080252PG	GRILLE LARGE BSB PIG GREY
6080831	PUMP UL DEAC 120VOLTS
6080928	HOSE ASSY UL DEAC LARGE
6080932	HOSE 1/4" PLASTIC 25 FEET
6081606	MOTOR MOUNT BKT-UL DEAC
6081635	MOTOR 3/4 HP 2 SP 110V
6081638	PUMP RECEPTACLE
6081639	FAN MOTOR RECEPTACLE
6081645	PLASTIC JUNCTION BOX
6082219	INSTNS INSTALL & OP UL DEAC
6280924	RUBBER WASHER FLOAT VALVE
6280933	FLOAT VALVE ADAPTOR UL
6280934	FLOAT VALVE BRASS BODY UL DEAC
6280935	FLEX HOSE FLOAT UL DEAC
6280941	OVERFLOW FITTING DIAL

Parts list

Replacement Parts List – 5000cfm

Component	Item Description
0120703	CLIP-HOSE CT24
0121912	CABLETIE 200x4.8MM KT20247
0121913	CABLE TIE 3502ORT18R/WOR CT95M
0122921	CAP PLAS.12mm002067700
0122924	CAP PLASTIC PLUG 1/2"
0141243	NUT 3/8 UNC NYLOC Z/P
0141435	SCREW-10x20 Hi-Lo HEX WASH S/S
0141479	THUMB SCREW SBB - SS
0141909	BOLT-3/8X1" ZP
0142331	WASHER 3/8X1-1/4X16G Z/P
6051313	NUT- RETAINING MKII
6080101PG	TANK CP2 PIGEON GREY
6080102PG	LID CP2 PIGEON GREY
6080108	WATER DISTRIBUTER SLOPE ASSEM
6080112	LOUVRE SPIGOT
6080113	CONNECTOR ASSY
6080114	CAP SD/DD P GREY 425D
6080117	FAN 425mm 15DEGREE PITCH
6080118	VENTURI 425mm
6080122	MTG BRACKET UL DIAL PUMP
6080130	VALVE WD 1/2" & BLEED 1/4"
6080141	FILTERCOOL CP2 SM 800x400x75
6080222PG	GRILLE CP2 SIDE DISCH SMALL
6080251PG	GRILLE SMALL BSB PG
6080831	PUMP UL DEAC 120VOLTS
6080915	BLEED RESTRICTOR BRACKET
6080920	TUBE GRILLE SMALL 490mm
6080922	TUBE DISTRIBUTER SHORT 910mm
6080923	TUBE DISTRIBUTER LONG 1170mm
6080924	TUBE 1/2" PUMP 410mm
6080938	TUBE 1/4" SIPHON BREAK 130mm
6081606	MOTOR MOUNT BKT-UL DEAC
6081630	MOTOR 1/2 HP 2 SP 110V

Parts list

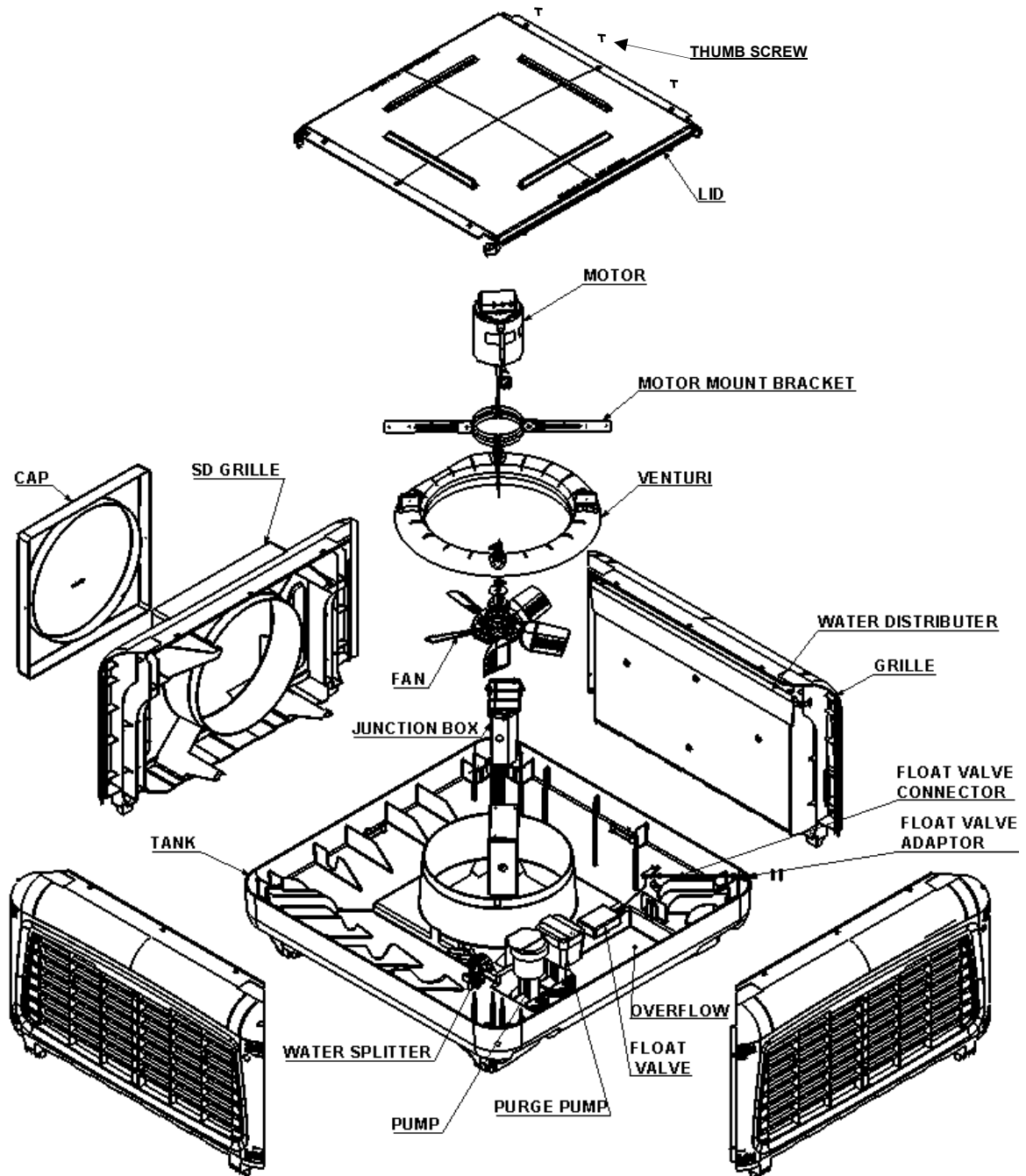

To Order Parts
www.bonairedurango.com

Maintenance

Spring Start-up

- **Clean pump.** Clean the pump once a year at start up.
Check the pump spout for blockage.
Ensure the impellor / shaft turn easily
If any hose connections have been removed during the pump cleaning process make sure that hoses and clamps are reconnected.
- **Check pads.** Check if the pads need to be replaced or washed
- **Check bleed off valve.** Check bleed off valve to ensure it is not blocked.

Winter Shutdown

- **Drain water.** If the cooler is not going to be used for an extended time the water should be drained from the cooler and connected water lines.
- **Cover unit.** Fit a cover to protect the unit when not in use for an extended time .

Warranty

Statement on Product Warranty (U.S.A.)

1. Warranty

Subject to the Conditions and Exclusions, Climate Technologies Pty Ltd provides the original purchaser with the following warranty:

Climate Technologies Pty Ltd warrants this appliance for a (2) two year period (parts only) from the date of purchase. During this period, a defective appliance or defective parts will be repaired or replaced free of charge at the election of Climate Technologies Pty Ltd.

In addition (20) Twenty year cabinet corrosion parts only warranty on the unit cabinet

2. Conditions and Exclusions

- a) The warranty only covers portable coolers manufactured by Climate Technologies Pty Ltd and purchased in the U.S.A.
- b) The warranty does not cover installation components that may be attached to the product manufactured by Climate Technologies Pty Ltd. These may include and is not limited to items such as ducting, flues, grills, piping, etc. These items remain solely the responsibility of the installer / owner.
- c) This warranty is only valid if the appliance is installed and operated in accordance with the manufacturer's instructions and for its designed and intended purpose at the nominated phase, voltage and frequency.
- d) Product fitness for purpose and overall system design / sizing are solely the responsibility of the installer / owner. This includes but is not limited to heat load calculations, air flow, system balancing, humidity, water quality, etc.
- e) Industrial or commercial use of this product will void the warranty. The appliance is designed for domestic use only.
- f) The product must be installed by a qualified person in the manner prescribed by local and statutory regulations and to the manufacturer's specifications.
- g) Warranty will only be given where proof of purchase is provided by the original purchaser and Climate Technologies Pty Ltd is satisfied that the appliance is within the warranty period.
- h) Warranty will not be provided where, in Climate Technologies Pty Ltd opinion:
 - i. There is nothing wrong with the appliance.
 - ii. The defective operation of the appliance is due to failure of electricity or water supply.
 - iii. Defects are caused by neglect, incorrect application, abuse or by accidental damage of the appliance.
 - iv. An unauthorized person has attempted to repair the appliance.
 - v. The appliance has been changed or modified in any way.
 - vi. A situation arises referenced in the trouble-shooting guide.
- i) Damage caused by elements such as wind, rain, lightning, floods, etc. along with power spiking and brownouts are not considered defective material or workmanship and as such are not covered by our warranty.

Warranty

- j) If there is no certificate of compliance for plumbing or electrical work, Climate Technologies Pty Ltd reserves the right to refuse warranty on non-compliant installations.
- k) No responsibility will be accepted for outside elements such as pests, animals, pets and vermin that may cause damage to the unit.
- l) Harsh environmental situations such as salt air that may cause damage are not covered.
- m) Responsibility or liability is not accepted for damage to contents, carpet, walls, ceilings, foundations or any other consequential loss or damage of whatever nature either direct or indirect resulting from installation, operation or misuse of the appliance.
- n) Parts replaced under warranty are warranted for the balance of the original Warranty Period.
- o) All warranties are non-transferable.
- p) The benefits conferred by this warranty are in addition to warranties and other rights in respect of the appliance, which the consumer has under State and Federal laws. This warranty must be read subject to that legislation and nothing in this warranty has the effect of excluding, restricting or modifying those rights.

3. Climate Technologies Pty Ltd

Climate Technologies Pty Ltd is a company incorporated in Australia (A.C.N. number 001 418 042). Reference to Climate Technologies Pty Ltd includes its subsidiaries and authorized distributors.

Warranty for Replacement Parts.

Parts replace under warranty are warranted for the balance of the Window Cooler's original warranty period.

Proof of Purchase

Please attach your proof of purchase here. Your receipt is your warranty and will be required to validate any warranty.

Dealer / Product Information

Dealer/Retailer:	
Address:	
Phone Number:	
Unit Model Number:	
Serial No:	

Service

6.0 Service Review

A qualified service technician should conduct any service work carried out on this ducted Evaporative cooling product. It is important that periodical service is carried out on the product to ensure the customer receives the efficiency benefits the product provides.

Only an authorised Climate Technologies service provider can carry out warranty service.

For Technical Advice/Warranties

1-800-939-2983

Monday thru Friday 8:00 A.M. – 1:00 P.M. Pacific Time

NOTES



Manufactured by
Climate Technologies
ABN 13 001 418 042

26 Nylex Avenue
Salisbury, SA 5108
Australia

www.bonairedurango.com