

- Air Hose Size: 3/8" x 100' or 50'
- Reel Air Inlet (F): 1/4" NPT
- Air Hose Outlet (M): 1/4" NPT
- Max Working Pressure: 300 PSI
- Maximum Air Flow: 25 CFM

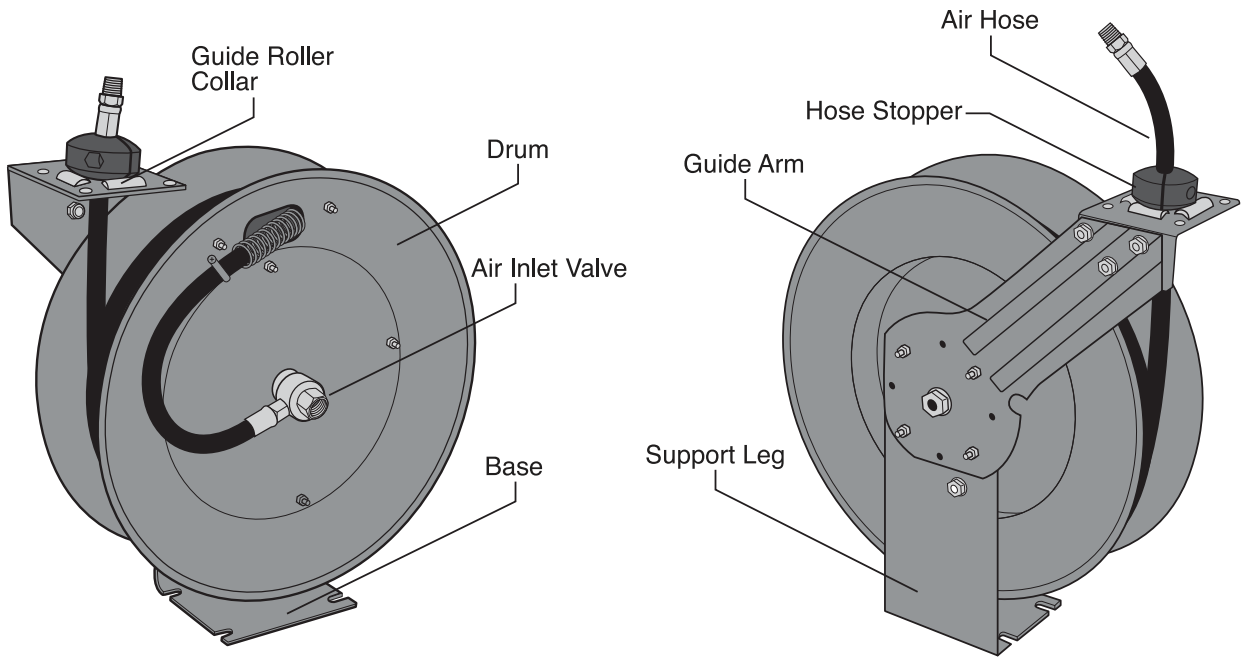

Refer to parts diagram on back page for part numbers

MOUNTING HOSE REEL

Typical Mounting Positions

Reel can be mounted on the floor, ceiling, or wall, wherever it is convenient. **When choosing a location, remember that you can only mount reel to a load-bearing structural member capable of supporting combined weight of reel, hose, and forces caused by pulling or maneuvering hose.** Mounting reel near air compressor may be desirable since you can connect the two with a shorter, less expensive length of hose. Also, air compressor controls will be conveniently nearby.

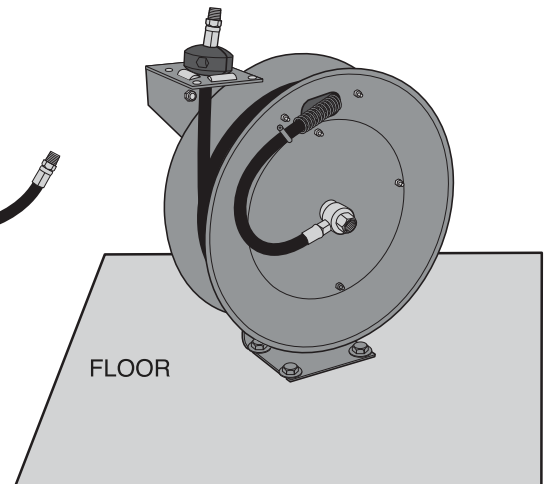
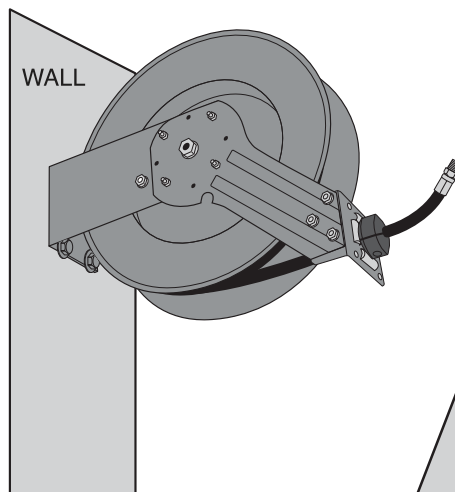
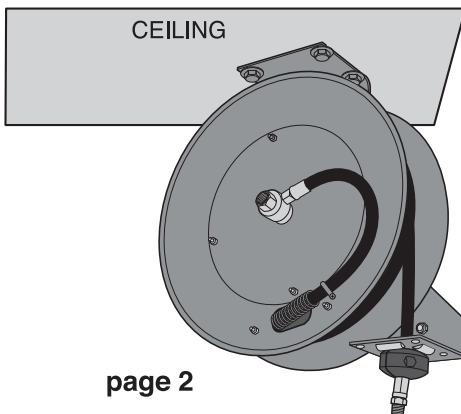

Suggested Mounting Configuration (Hardware Not Included)

Use 7/16 inch Bolt

WOOD - Lag bolt, lock washer and washer

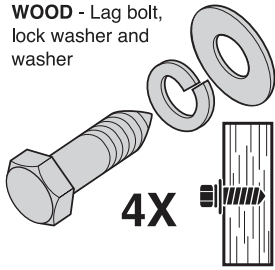

METAL - Bolt, two washers, lock washer and nut

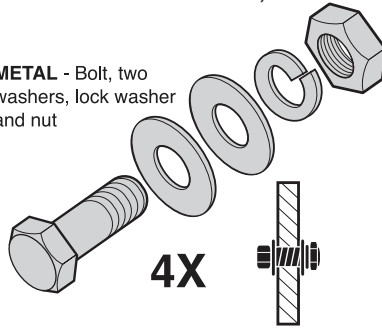

MASONRY - Bolt, lock washer, washer and anchor

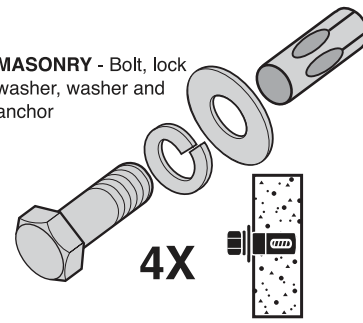

CAUTION: CEILING MOUNTING REQUIRES TWO PEOPLE. DO NOT ATTEMPT TO MOUNT HOSE REEL TO CEILING BY YOURSELF. USING A LADDER CAN BE DANGEROUS AND IS NOT RECOMMENDED.

1. Use support base #6 as a guide to mark hole locations.
2. Drill holes for bolts. Keep drill steady and in line with hole to prevent wobbling and enlarging of hole.
3. Pre-install one pair of hardware and tighten leaving just enough space to fit slotted base.
4. Hang hose reel by sliding slotted base onto pre-installed hardware. **DO NOT LET GO OF HOSE REEL!**
5. While continuing to support reel, install second pair of hardware. Tighten all hardware until snug. Do not overtighten.

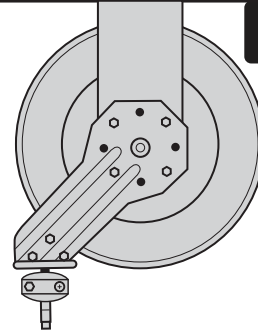

CEILING

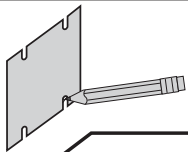

1. Use support base #6 as a guide to mark hole locations.

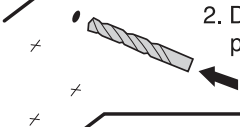

2. Drill holes for bolts. Keep drill steady and in line with hole to prevent wobbling and enlarging of hole.



3. Pre-install lower pair of hardware and tighten down leaving just enough space to snugly fit slotted base.



4. Hang hose reel by sliding slotted base onto pre-installed hardware. Carefully let go of hose reel, making sure its weight is being supported. Hose reel should support itself in this position long enough to install remaining hardware.

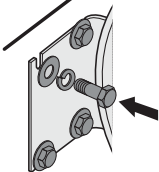

5. Immediately install second set of hardware. Tighten all hardware until snug. Do not overtighten.

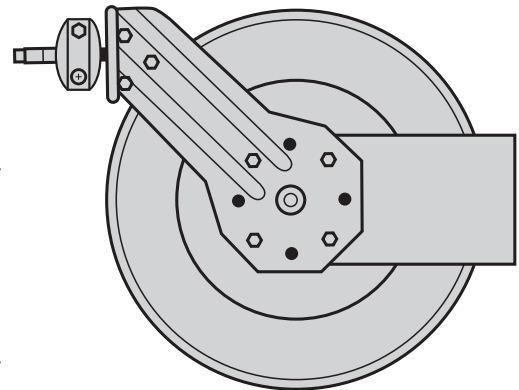

WALL

1. Use support base #6 as a guide to mark hole locations.

2. Drill holes for bolts. Keep drill steady and in line with hole to prevent wobbling and enlarging of hole.

3. Set reel in position, aligning slotted base with holes. Install all hardware, tightening until snug. Do not overtighten.

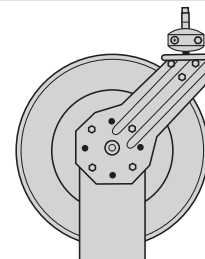

FLOOR

MAKING ADJUSTMENTS

Adjusting the Guide Arm

1. Pull out 3-4 feet of hose and lock reel in position.

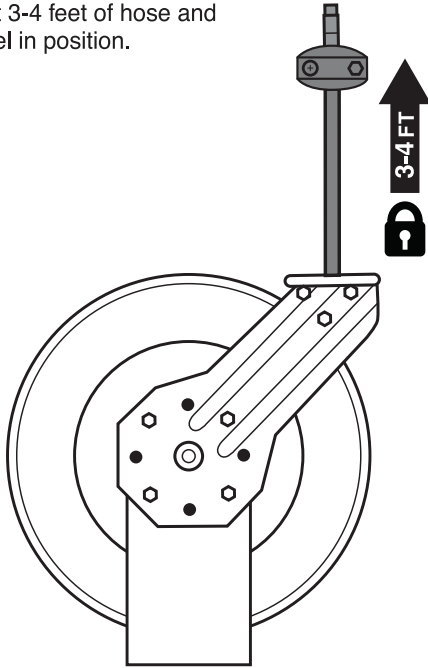

2. Remove the four bolts connecting guide arm to base.

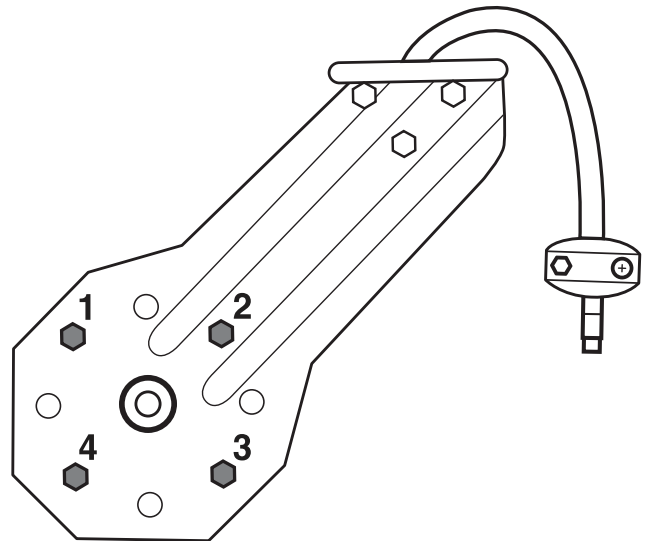

3. Rotate guide arm to one of five positions desired. Replace four bolts and tighten.

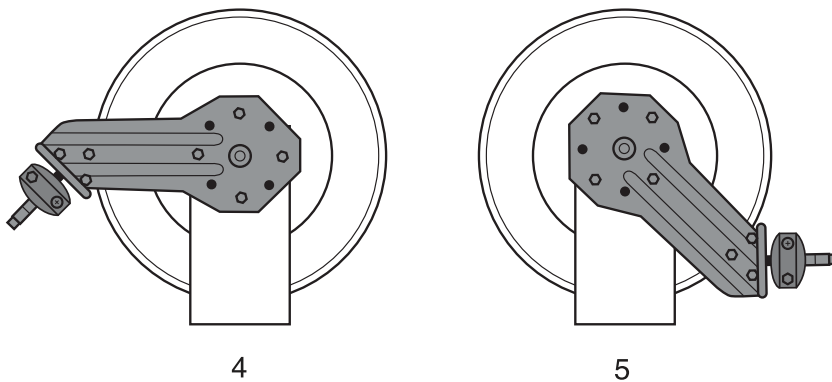
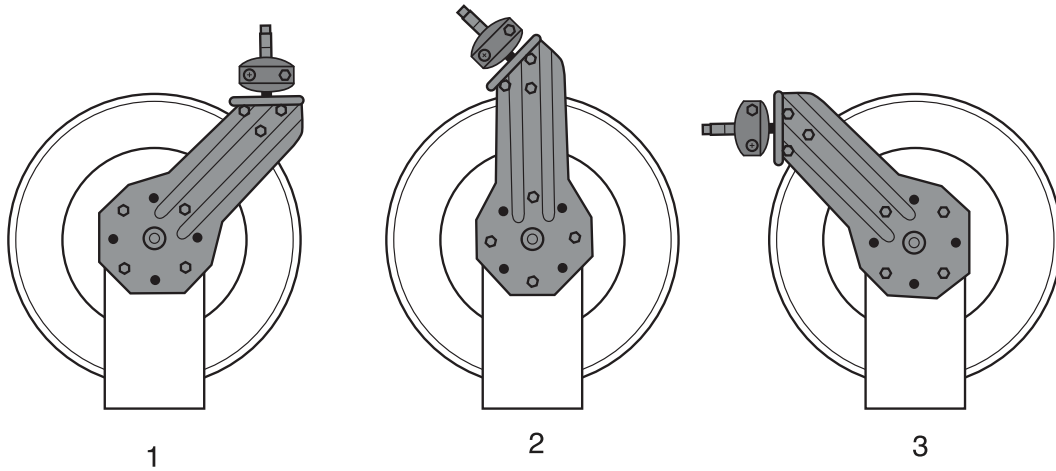

Adjusting Hose Stopper Position

The hose stopper (part 39) determines the length of hose that remains outside of reel. To adjust stopper position, first pull hose out past the desired position of hose stopper. Lock reel in position. Loosen (but do not remove) both stopper bolts just enough so stopper can slide along hose. Move stopper to desired position. Tighten stopper bolts until hose stopper cannot slide. Do not overtighten bolts.

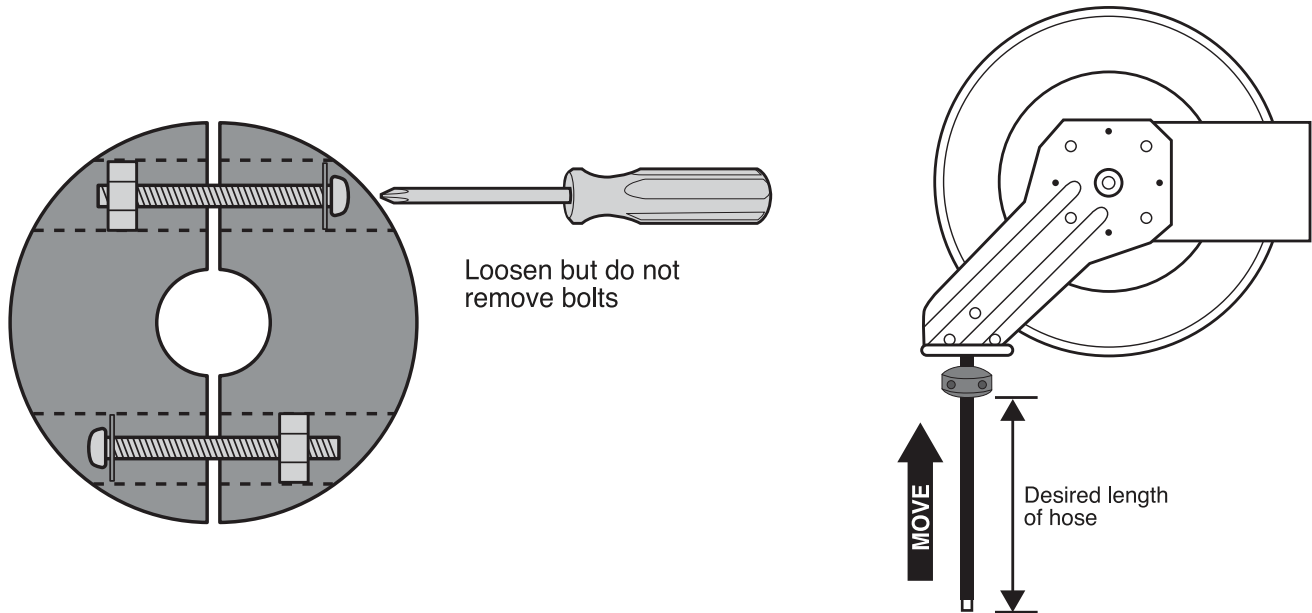

Adjusting Recoil Tension

Hose reel is shipped with spring tension properly set. Be aware that spring tension is calibrated to retract entire length of air hose. If you are working with only part of the air hose length, recoil action may seem slower than expected. However, if you feel hose rewinds too quickly or too slowly, you can easily adjust the tension of the main recoil spring by simply turning the reel drum to a new "home" position.

! DO NOT SET TOO MUCH TENSION IN SPRING. Damage to spring could result.

1. Disconnect incoming air supply.
2. Pull out about two feet of hose and lock reel in position.
3. Remove hose stopper (part 39). Pull hose backward through hose guide.
4. While firmly gripping edge of reel drum, turn reel clockwise (as viewed from air inlet side) just enough to release locking pawl. DO NOT RELEASE REEL DRUM, or it will spin uncontrolled until all spring tension is lost.

To Increase Tension: Turn reel drum clockwise until desired tension has been added. Lock reel in nearest locking position.

To Decrease Tension: Allow reel drum to slowly turn counterclockwise until extra tension has been released. Lock reel in nearest locking position.

5. Feed hose through hose guide. Re-attach hose stopper.
6. Connect incoming air supply.

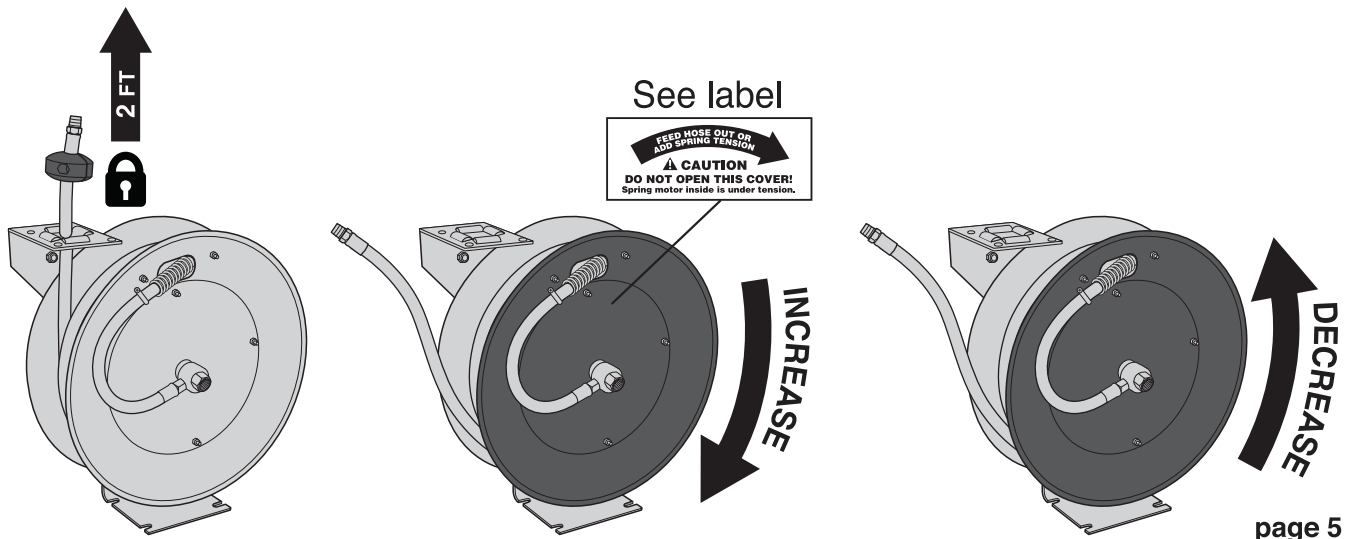

ATTACHING INCOMING AIR

For maximum leak-free performance, air inlet valve is made of solid brass. Brass is a soft metal and overtightening or rough handling can cause damage or breakage. Use care when working with air inlet valve. For a tight, leak-free connection, follow all instructions carefully.

Option 1

Wrap incoming hose end with thread sealing tape. AIR INLET VALVE CANNOT ROTATE, do not attempt to turn. To prevent rotation, hold air inlet valve with wrench to stabilize it while connecting air hose. Thread air hose into air inlet valve. Using second opposing wrench, tighten connection just until snug.

Option 2

Use a 3/8" 90° connector (not included). Wrap threaded end with thread sealing tape. AIR INLET VALVE CANNOT ROTATE, do not turn. To prevent rotation, hold air inlet valve with wrench to stabilize it while connecting air hose. Thread 90° connector into air inlet valve. Using second opposing wrench, tighten connection just until snug. Next, wrap incoming hose end with thread sealing tape. Thread into swivel end of 90° connector. Using two opposing wrenches, tighten connection just until snug.

To ensure optimum performance and efficiency, check all connections for leaks. With air system pressurized, brush each connection with soapy water. Inspect closely. Air bubbles indicate leaking air. Tighten any leaking fittings.

OPTION 1

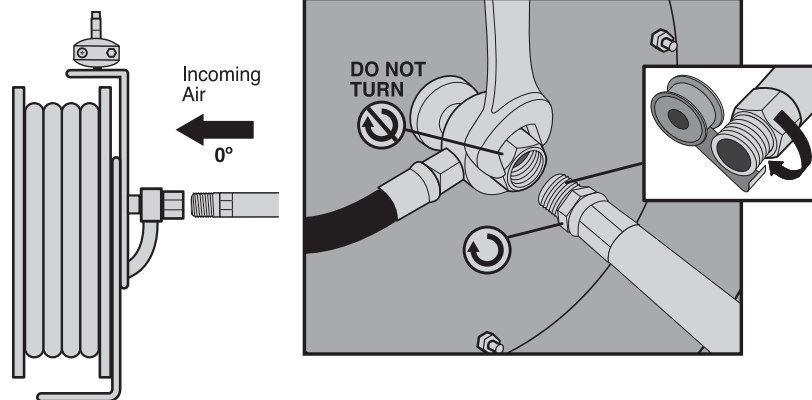

OPTION 2

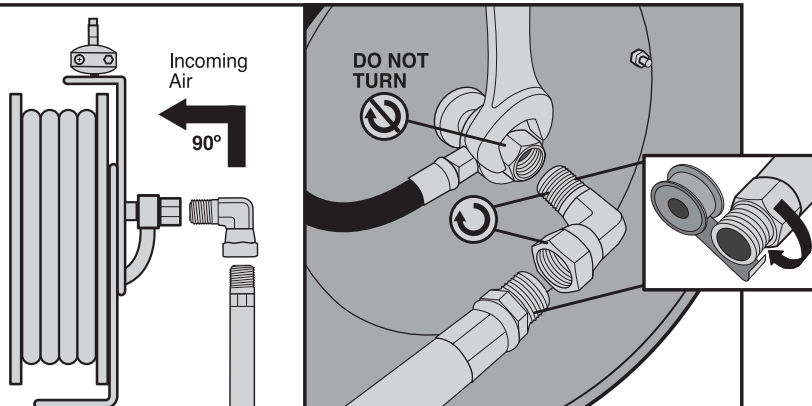

Replacing Locking Pawl

Sometimes with heavy use, the locking pawl can begin to wear causing poor engagement with ratchet teeth. This can result in slipping or difficulty locking. It is easy to replace and can be done while hose reel is mounted.

1. Reel should be in fully retracted position ("home"), with hose stopper resting against guide roller collar. Be sure locking pawl is not engaged with ratchet teeth, and that there is enough clearance between pawl and teeth to allow free and easy removal and installation of locking pawl assembly.
2. Unhook return spring from anchor point. Loosen and remove lock nut. Remove old locking pawl assembly from support leg.
3. Insert new locking pawl assembly through support leg. Thread on lock nut and tighten until snug. Hook end of return spring through anchor point.
4. Verify function of locking pawl by pulling hose out and locking reel in position.

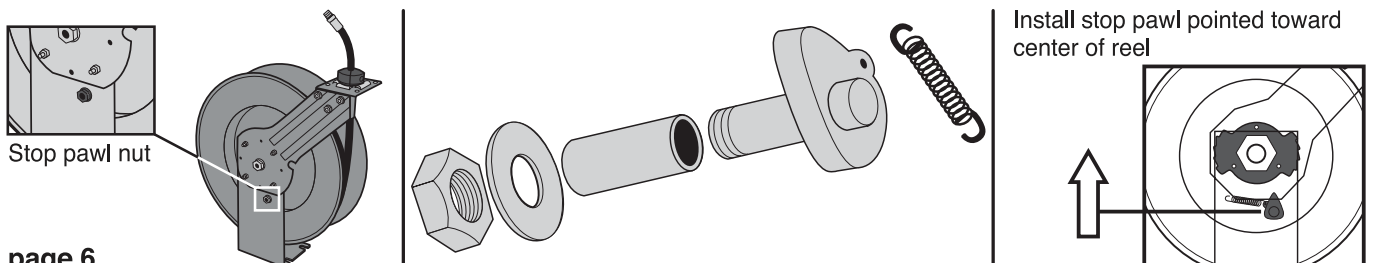

Replacing Air Inlet Valve O-rings

1. Disconnect incoming air supply. Unscrew air inlet valve assembly (part 11) from axle (part 23) by fitting wrench onto hex portion of valve and turning counterclockwise.
2. Remove retaining ring (part 13) and slide air inlet valve swivel connector (part 12) off from air inlet valve body.
3. Remove (2) worn O-rings from air inlet valve and replace with new parts.
Reverse above procedure to re-assemble.



For easy installation and best seal, thinly coat o-rings with petroleum jelly.

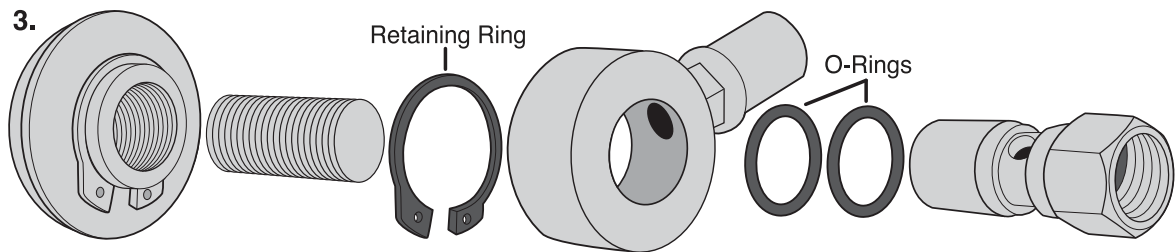
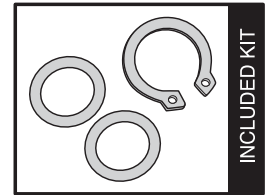
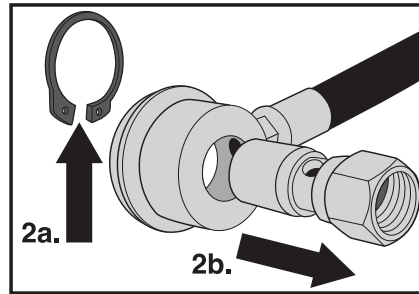
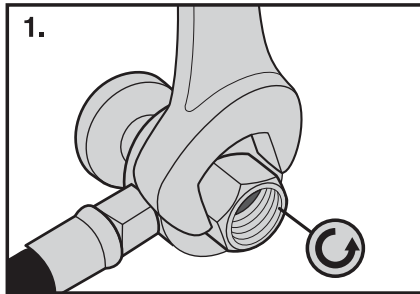

Replacing Hose

If hose becomes damaged, it may be necessary to replace it. In most cases, air hose can be replaced while reel is still mounted. **Replace air hose with same diameter and length of original hose. Installing a longer or shorter hose will require Adjusting Recoil Tension (page 5).**

1. Disconnect incoming air supply. Pull out about 1 foot of hose and lock reel in position. **DO NOT UNLOCK HOSE REEL** during this installation process. If reel becomes unlocked, it will spin at uncontrolled speed, possibly resulting in damage to internal spring.
2. Remove hose stopper. Pull hose backward through guide roller collar. Unwrap (counterclockwise, when viewed from air inlet side) until reel is empty.
3. Remove hose clamp. Save for re-installation. Disconnect hose end from air inlet assembly. Pull hose end back through slot in reel drum. Remove spring guard from old hose.
4. Place spring guard on new hose. Feed hose end through slot in reel drum. Wrap end of new hose with thread sealing tape. Connect to air inlet assembly. Re-install hose clamp. Make sure spring guard is aligned correctly in slot to protect hose from sharp metal edges.
5. Wrap hose around reel (clockwise) until 1 - 2 feet of hose remains.
6. Feed hose end through guide roller collar. Re-attach hose stopper in desired position. Unlock hose reel and rewind until hose stopper rests against guide roller collar. Connect incoming air supply.

