

GoWISEUSA®

HIGH-PERFORMANCE Professional Blender Streamline

Instruction Manual

GW22503



WWW.GOWISEUSA.COM

Table of Contents

Product Introduction	3
Important Safeguards	4
Specifications	6
Assembly & Parts List	6
About your Blender	7
Before First Use	8
How to use your Blender	9
Tips	13
Cleaning and Storage	15
General Warranty	16

Product Introduction



Blend your favorite smoothies, sauce, dips, and more with the GoWISE Professional series of High-Performance Professional Blender. The blenders are built with a 1450W motor and 8 stainless steel blades to crush, slice, dice and chop any ingredient resulting in a creamy or silky refreshment or snack. They come with a 67-oz BPA-free Tritan pitcher, so the whole family can enjoy refreshing and tasty treats.

Important Safeguards

Before using electric appliances, basic safety procedures should always be followed including the following:

1. Read the instruction manual completely.
2. Do not immerse the motor base or cord/plug in water or other liquid.
3. Please make sure children are supervised if present during the use of this appliance.
4. Unplug the appliance before putting on or taking off parts and before cleaning to avoid electric shock and injury.
5. Avoid contact with moving parts.
6. Do not operate the appliance if the cord or plug is damaged in any way. Contact GoWISE USA customer support for more instructions.
7. Do not operate the appliance after it malfunctions, or is dropped or damaged. Contact GoWISE USA customer support for more instructions.
8. This product is not for outdoor use.
9. Do not let the cord hang over the end of a table or counter.
10. Keep hands and utensils out of the container to prevent the risk of injury or damage to the blender. A scraper may be used when the blender is not running.
11. The blades are sharp. Take extra caution when handling the blades.
12. Be careful to not power on the Blender when the lid is not secure.
13. Do not use attachments, including canning jars, with the blender. The use of attachments that are not recommended by the manufacturer can result in injury and damages.
14. Do not remove the lid cap of the two-piece cover when blending hot liquids.

Important Safeguards (cont)

15. You must only use the supplied power cable and only connect to a grounded 120-volt 15amp power socket.
16. Do not cut the ground pin or use an extension cord with this product.
17. Do not use in a dusty atmosphere.
18. Do not drop. Dropping or rough use of the unit will cause damages to the product.
19. Do not place near strong magnets or strong electric currents.
20. When the blender is not in use, turn off and unplug the blender from the power source.
21. Do not attempt to repair, open, or alter any components of the blender. In the case of improper use or if the blender has been altered and repaired in any way, the warranty will be void.
22. GoWISE USA does not accept responsibility for additional or consequential damage other than what is covered by legal product responsibility.
23. GoWISE USA is not responsible for the end use of this product or when used for purposes that are not specified.
24. Be sure to read the installation, operation, and maintenance instructions thoroughly before installing or servicing this equipment. Improper installation, adjustment, alteration, service or maintenance can cause property damage, injury, or death.
25. All maintenance and repairs must be made by a factory authorized provider. Do not attempt to repair or alter the appliance in any way. This will void the warranty.

WARNING: Do not store or use gasoline or flammable vapors and liquids near this or any appliances.

Assembly & Parts List

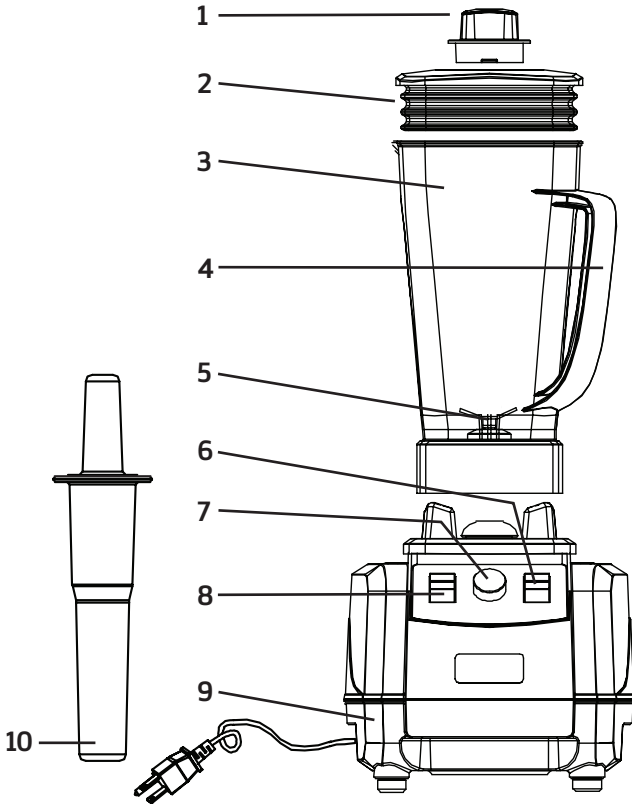

- | | | |
|------------------|-----------------------|-----------------|
| 1. Refilling cap | 5. Blade group | 8. Power |
| 2. Lid | 6. Pulse switch | 9. Base |
| 3. Pitcher | 7. Speed control knob | 10. Tamper knob |
| 4. Handle | | |

Specs

Color	Voltage	Power	Capacity
Black	120V/60Hz	1450W	67 oz

About your Blender

ON/OFF

The ON/OFF switch activates the motor on a setting.

Pulse Function

The PULSE function is used for extra power in short bursts. The switch activates the blades to turn at their highest speed setting and can help with crushing ingredients, such as ice.

Tamper

The tamper is used to push ingredients down into the blades. When an ingredient gets stuck or too many ingredients are in the blender during a cycle use the tamper to move ingredients around to resume blending.

Adjustable Speed Dial

The speed dial allows you to adjust the rotation speed of the blades starting from the slowest speed to the highest speed. This dial provides more control over how to chop or blend ingredients.

Soft Start Function

The blender will gradually accelerate to the set speed.

The blender has dual protection circuits, one for the motor over heat and one for the over current supply.

Before First Use

Remove all packaging material and promotional labels before using your blender for the first time. Wash the pitcher, lid, lid cover and tamper in warm soapy water before using it for the first time. Position the blender on a firm and leveled table or counter.

NOTE: DO NOT IMMERSE THE PITCHER IN WATER OR GET THE BASE OF THE Pitcher WET. The base of the pitcher contains connections that power the blender. No parts of the blender are dishwasher safe.

Using Your Blender

1. Ensure that the ON/OFF switch is in the OFF position. Plug the unit into a household power outlet. Make sure the blender sits on a level and dry surface, moisture may result in the blender moving during operation.
2. Place the pitcher onto the motor base correctly. You may need to rotate the pitcher so that the connection aligns correctly.
3. Add desired ingredients. Do not fill above the maximum level.
4. Press the lid firmly onto the pitcher. Place lid cover then twist to lock the lid cover.
5. Check and ensure that the speed dial is set to MIN.
6. Flip the ON/OFF switch to ON to turn the blender on. The blender will beep to indicate whether it is on. The motor will gradually accelerate to the set speed.

WARNING: Do not place any body parts or foreign objects in the blender while it is in use. The blades are very sharp and can cause serious injury.

NOTE: You may notice a slight odor from the blender motor during the first use. This is normal and expected when the motor is being used for the first time.

7. Adjust the speed dial to the desired setting and blend ingredients for the required time. **NOTE:** The speed of the blender will reduce slightly after 30 seconds of operation and then return to the set speed. This improves the blending performance by briefly reducing the rotation speed of the blade assembly. This allows the ingredients to settle closer to the blades for optimal mixing.

WARNING: Do not leave the blender unattended during operation.

Using Your Blender (cont)

8. If the ingredients are not circulating, remove the lid cover carefully and use the tamper to push or mix the ingredients as required.

WARNING: Only use the tamper with the pitcher in place to prevent personal injury.

9. Flip the ON/OFF switch to OFF and speed dial to MIN once finished.
10. Remove the pitcher from the motor base, then remove the lid. Pour mixture from the pitcher, use a spatula or plastic scraper if necessary. **DO NOT USE METAL UTENSILS. IT MAY DAMAGE THE BLADES.**

If you have any issues with the blender, please stop using the blender and contact customer support at 1-855-233-9199.

Using the Pulse Function

The pulse function provides extra power in short bursts. This function will cause the blades to rotate at their highest speed. Pulse can be used when the blender's ON/OFF switch is in the ON or OFF position.

1. Follow steps 1-5 under "Using Your Blender" section.
2. Flip the "Pulse/OFF" button to PULSE.
3. Adjust the speed to the desired setting. Use PULSE function as desired.
4. Flip the ON/OFF switch to OFF and speed dial to MIN once you have reached the desired consistency.
5. Remove the pitcher from the motor base and remove lid. Remove contents from the pitcher as instructed on step 10 under "Using Your Blender" section.

Using the Tamper

The tamper is used to press ingredients down towards the blades. It is recommended to move the tamper either straight down or around the sides for the best results. Do not use excessive force with the tamper.

1. Follow steps 1-3 under "Using Your Blender" section.
2. Press the lid firmly into the container, do not insert the lid cover.
3. Insert the tamper through the lid hole.
4. Turn the blender ON or use the PULSE function. Use the tamper to push down ingredients through the lid hole.

WARNING: Do not force the tamper down the lid opening as this may cause damage to the blender and the tamper. **NEVER USE THE TAMPER WITHOUT THE LID IN PLACE.**

TIPS

Crushing Ice

For best results when crushing ice, the ice must be dry, (not watery or melting ice) and use the tamper.

1. Fill the container with no more than 1/3 full of ice.
2. Press the lid firmly into the container, remove the lid cover.
3. Turn on the blender and gradually increase to maximum speed.
4. Push down the ice to the blades using the tamper.
5. Stop blending before the ice starts melting, which is approximately 10-15 seconds. This ice will clump together and not be as powdery.
6. Remove the ice by turning the pitcher upside down. Use a plastic utensil and carefully shift ice that is stuck underneath the blade.

Heating

The blender can heat up ingredients making it perfect for making soups in minutes. This process results from the friction produced from the rapid rotation of the blades. The heating process will take about 5 to 7 minutes once ingredients are puréed. Refer to the soup section of the recipe book.

WARNING: Take extra caution when blending hot liquids or making hot soups because there is a risk of burning and injury.

NOTE: The metal plate under the pitcher heats due to friction when the blender is operating. Be sure not to touch the metal plate after prolonged use.

TIPS

Jammed Ingredients

When blending certain ingredients, chunks may get stuck below the blades. This is indicated by a loud noise from the blender. In this instance, please follow the instructions below:

1. Flip the ON/OFF switch to OFF.
2. Remove the pitcher from the motor base and remove the lid.
3. Use a plastic utensil and carefully move the ingredients from underneath the blades.
4. Correctly place the pitcher back onto the motor base, insert the lid and proceed with blending.

NOTE: If the ingredients are continuing to get jammed, remove the large chunks and chop them down to a smaller size then continue blending.

Juicing

The blender will blend the skins and seeds of fruits and vegetables. This ensures that the fiber and essential vitamins and nutrients are retained. The juice will be thicker due to fiber and pulp in the juice. You can strain the pulp using a piece of muslin cloth or a fine strainer, which will result in a consistency similar to juice.

1. Chop your fruits or vegetables to a small, manageable size and place in the pitcher.
2. Blend ingredients as per instructions listed on page 13-14.

NOTE: Large seeds like seeds from peaches or avocados should be removed before placing them in the blender.

3. Strain juice if desired.

Cleaning and Storage

1. Unplug the motor base from the power outlet.
2. Use a moist cloth to wipe down the exterior. DO NOT SUBMERGE THE MOTOR BASE IN WATER.
3. Clean the pitcher, lid, lid plug and tamper in warm soapy water, rinse and dry.

NOTE: No parts of the blender are dishwasher safe.

If you have any questions regarding your product, please contact GoWISE USA customer support at **1-855-233-9199** or via e-mail **support@gowiseusa.com**.

General Warranty (Excluding Refurbished/Auction Items)

General Warranty (Excluding Refurbished/Auction Items)

GoWISE USA has a 1-year limited warranty for all products. Products are warrantied against defects in materials and workmanship for 1-year from the date of purchase, when used in accordance with the instructions provided. This warranty does not cover damages or wear resulting from accident, misuse, abuse, commercial use, or unauthorized adjustment and/or repair.

This warranty ONLY covers defects in materials and workmanship and will NOT pay for:

- Items that wear out from normal use including blender pitchers, blades, lids, fryer baskets, pans, pressure cooker pots or lids.
- Damage or failure of this appliance resulting from accident, alteration or misuse.
- Discoloration or surface rust which are conditions that result from normal use or improper maintenance.
- Damage of failure of this appliance resulting from unauthorized modifications made to this appliance.
- Noises associated with the ordinary operation of appliances
- Costs associated with removal of the product from home for exchange including shipping costs to and from our facilities.

If the item was a gift and there is not gift receipt, please contact the gifter for a copy of the receipt or invoice. If it's inappropriate, please request the gifter to get the warranty claim started.

If a product is replaced, the replacement product warranty coverage will cover the warranty that was left from the original product. The warranty does not restart from the date of the replacement on the website.

PLEASE CALL: 855-233-9199 for RETURN INSTRUCTIONS.

WE DO NOT SERVICE PRODUCTS OUTSIDE THE 48 CONTINENTAL UNITED STATES. (WE WILL SHIP TO A FREIGHT FORWARDER FOR CUSTOMERS)

NOTE: Customers are responsible for all return shipping costs. When item(s) are returned under warranty as being defective, they are thoroughly tested to verify manufacturer defect. If any item(s) are determined to be in proper working order after testing, all shipping costs to have the product returned to the customer will be the responsibility of the customer

This warranty gives you specific legal rights and you may have other rights which vary from state to state.

Refurbished Policy

All Refurbished items are sold "AS IS" and are not eligible for refunds. If a refurbished item is received either defective or DOA (Dead on Arrival), customers MUST contact GoWISE USA customer support within 30-days from delivered date.

THIS WARRANTY ONLY APPLIES TO REFURBISHED ITEMS THAT ARE PURCHASED DIRECTLY FROM GOWISE USA AND DOES NOT APPLY TO REFURBISHED ITEMS THAT ARE PURCHASED FROM 3RD PARTY SELLERS.

Regarding Purchase From 3rd Parties

In order for the GoWISE USA customer service team to look up the warranty information regarding the product(s), the original order information and/or proof of purchase is required. Without this information GoWISE USA will be unable to move forward with providing a replacement under warranty, as we do not know the date or origin of the purchase. GoWISE USA does not have a working business relationship with 3rd party selling sites or services or individuals which are not listed below as one of our Authorized Retailers. GoWISE USA is not responsible for making inquiries to such 3rd parties for the purpose of obtaining documentation. It is the responsibility of the person(s) making the warranty claim to provide original documentation such as order information and/or a receipt so that customer service can process your request. Any claim made under GoWISE USA warranty guidelines must be made by original purchaser of the product(s). Any defective product will be replaced as long as the issues with the device fall within warranty guidelines.

Authorized Retailers

- Amazon
- GoWISE USA (Amazon, Sears Marketplace)
- WayFair
- morningsave.com
- Houzz
- Home Depot

Notes

GoWISEUSA®

www.gowiseproducts.com
support@gowiseusa.com
1-855-233-9199

- To ensure correct use of this appliance, read these instructions carefully and thoroughly
- Please keep this manual for future reference.
- Thank you for purchasing this GoWISE USA product.