

TITAN

OWNERS MANUAL

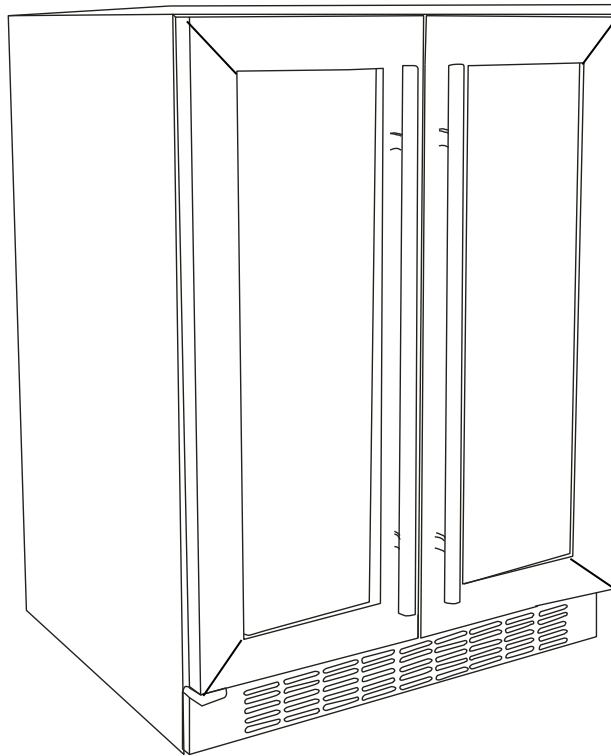

FRENCH DOOR DUAL ZONE BUILT IN BEVERAGE & WINE COOLER

TS-CBWC6021DZ

Table of Contents

Table of Contents	1
Important Safety Information	2
Introduction	4
Identification of Parts	5
Installation	6
Installation Clearance Requirements	7
Electrical Requirements	8
Leveling the Unit	8
Installing the Door Handle and Shelves	9
• DOOR HANDLE	
• SHELVES	
Operation	10
• CHECK POINTS BEFORE OPERATION	
• CONTROL PANEL	
• ADDITIONAL FUNCTIONS	
Storage	12
Sounds	13
Defrosting	13
Preparing the Unit for Storage	13
Cleaning, Care and Maintenance	14
• EXTERIOR	
• INTERIOR	
Energy Saving Tips	14
Trouble Shooting	15
Specifications	16
Warranty	17

!!IMPORTANT!

Instructions Before Using Your Appliance

Before use, make sure all packaging labels and materials are removed from the unit. Be sure to keep track of all included parts and pieces before discarding packaging materials. It is advised that you keep the original box and packaging materials in case you are ever to move or ship the appliance in the future.

Clean the interior surface with a soft cloth. Allow the unit stand for at least 24 hours before use; this allows the cooling system time to settle from transit.

This owner's manual is provided for reference use only. Specifications may change without prior notice. Refer to the product label on the back of your unit for the latest technical information.

Important Safety Instructions

Improper handling can cause serious damage to the Titan appliance and/or injury to the user. This appliance is designed for domestic indoor use only. Use of the unit for industrial or commercial or any other purposes will void the warranty. Please read and follow all instructions before using the appliance to reduce the risk of fire, electric shock or injury."

⚡ SAFETY WARNING ⚡

General



- ◆ This product is not intended to be used or operated by children.
- ◆ Children should be supervised to ensure that they do not play with this appliance.
- ◆ This unit is heavy. Always use at least two people to move and install the appliance to prevent injuries.
- ◆ Do not place any other appliances or heavy objects on top of the unit.
- ◆ Only use in an upright position on a flat, leveled surface and with proper ventilation.
- ◆ Do not turn the unit upside down, on its side, or at an angle.
- ◆ Do not place hot or warm food or beverages into the unit until they reach room temperature.
- ◆ This unit is designed to be used indoors, and must be protected from weather elements such as direct sunlight, rain, snow or moisture.
- ◆ Do not place the unit near to ovens, grills, or other sources of high heat.
- ◆ Do not twist or pinch the power supply cord.
- ◆ Do not use solvent-based cleaning agents or abrasive solutions on the unit, which may damage or discolor the interior and exterior.
- ◆ Install the appliance in a well-ventilated area with ambient temperature above 50°F and below 95°F.
- ◆ The temperature range for this cooler is optimized for wine and beverage storage. Other food items may require a different storage environment.
- ◆ Do not move the appliance without emptying the contents and securing the door in a closed position.

Electrical



- ◆ Plug the unit into a grounded 3-prong outlet. Do not remove grounding prong, do not use an adapter and do not use an extension cord.
- ◆ It is recommended that appliance be connected on its own circuit. Use outlets that cannot be turned off by a switch or a pull chain.
- ◆ The unit must be installed in accordance with state and local electrical codes.
- ◆ A standard electrical supply (115 V, 60Hz) that is properly grounded in accordance with the National Electrical Code and local codes and ordinances is required.
- ◆ Do not operate the unit with a power plug missing the ground plug, a damaged cord or a loose socket.
- ◆ Do not start or stop the unit by switching the circuit's power on and off.
- ◆ Always turn the unit off and unplug it when cleaning.
- ◆ Unplug the unit if it is not going to be used for an extended period of time.
- ◆ Be sure the appliance is properly grounded.
- ◆ Do not plug or unplug the unit with wet hands.
- ◆ Do not bypass, cut or remove the grounding plug.
- ◆ Never repair the unit while it is plugged in.
- ◆ Unplug the unit immediately if it makes strange sounds, emits smells or smoke.
- ◆ Do not remove any part of the casing unless instructed by an authorized technician.
- ◆ Do not attempt to repair or replace any part of the appliance unless it is specifically instructed in the manual.
- ◆ Contact customer service if the unit needs service.

Introduction

Congratulations on purchasing your Titan appliance! We at Titan offer products with quality and features that compliment your lifestyle. To find out more about this product and our other products please visit our website at www.titan-appliances.com.

This owner's manual contains important information on how to install, use and keeping your appliance to work efficiently at its peak performance levels.

To safely transport your appliance in future, please save the original product packaging.

Proof of Purchase:

For future reference, please write down the model number and serial number below.

Model Number:

Serial Number:

Date of Purchase:

Both the model number and the serial number are located on the product label on the back of your unit and are needed for service under warranty. We suggest stapling your receipt to this manual as it serves as the proof of your purchase and needed for service under your warranty.

Before contacting customer service, please ensure that you have done the following:

1. If the unit is damaged when you receive it, please contact the retailer or dealer that sold you the appliance right away.
2. Please read this owner's manual and follow the instructions and recommendations in order to properly install, operate and maintain the unit.
3. Always refer to the trouble-shooting section of this owner's manual as it contains valuable information and suggestions on how to solve common issues.
4. For the latest information on this product and additional troubleshooting suggestions please visit our website at www.titan-appliances.com
5. Should you need any help on the warranty service please contact our customer services at service@titan-appliances.com

Identification of Parts

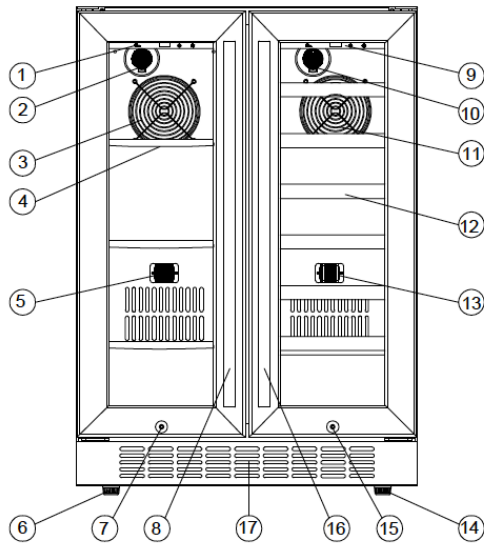

Left Zone Beverage Cooler	1	Temperature Control
	2	Carbon Filter
	3	Interior Fan
	4	Glass Shelves - 3
	5	Interior Sensor
	6	Left Leveling Leg
	7	Door Lock - Left Zone
	8	Door Handle - Left Zone
Right Zone Wine Cooler	9	Temperature Control
	10	Carbon Filter
	11	Interior Fan
	12	Wire Shelves - 6
	13	Interior Sensor
	14	Right Leveling Leg
	15	Door Lock - Right Zone
	16	Door Handle - Right Zone
	17	Front Vent

Carbon Filter:

This built-in carbon filter protects wine by acting as a natural barrier against harmful odors

Interior Fan:

This air-cooled unit has an internal fan that helps to provide more consistent temperature.

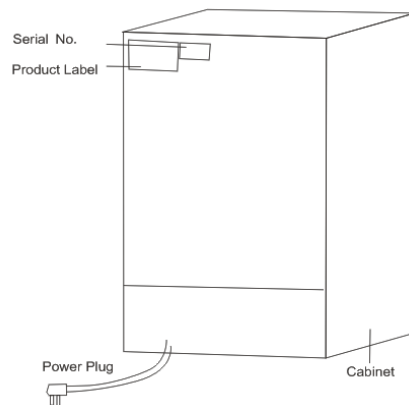

Note:

Depending on the unit's exposure level to odor, the carbon filter should be replaced every 3-6 months. If the unit is installed in kitchen the replacement should be carried out every 3 months.

Tip:

Please obtain the model and the serial numbers of the unit prior to installation.

Installation

Before installation, please check and ensure that:

1. The appliance should be installed in accordance with local electrical code requirements.
2. The appliance should be placed in a location that is strong enough to support its total weight – always assume the weight when the appliance is fully loaded.
3. The appliance must be placed in its upright position for at least 24 hours before plugging in and powering on to allow the compressor's oil to settle.



WARNING: Unpacking the Appliance

1. Always have two or more people to shift and install the unit to avoid back or other injuries.
2. Remove packaging materials carefully. Any shipping tape and glue from your appliance should be removed before using.
3. Never use sharp instruments, rubbing alcohol, flammable fluids, or abrasive cleaners when removing the tape or glue. These products can damage the surface of your appliance.

IMPORTANT:

Do not remove any safety, warning, or product information labels from your appliance.

TYPES OF INSTALLATION:

This appliance can be installed as a free standing or built-in unit. Keep in mind adequate ventilation and access for service is a must.

1. For free-standing installation:
 - Allows the installation of the appliance in almost any place you desire.
 - Please follow the stated instructions for electrical requirements, and leveling of the appliance.
2. For built-in installation:
 - Allows the installation of the appliance under a counter or in a kitchen cabinet. Please ensure to provide the required clearance space around the appliance.
 - Please make sure to allow adequate ventilation space around and for the back of the unit.
 - Place the appliance in front of the installation location. Adjust the feet and place the unit flat on the floor or on a platform depending on your installation requirements.
 - If the electrical outlet for the appliance is behind the cabinet, plug in the appliance.
 - Push the appliance into position.
 - Do NOT install the unit behind a closed cabinet door.

Installation Clearance Requirements

For built-in / under-counter installation, allow at least 2-3 inches of clearance at the back as shown in the below diagram to ensure proper service access and ventilation.

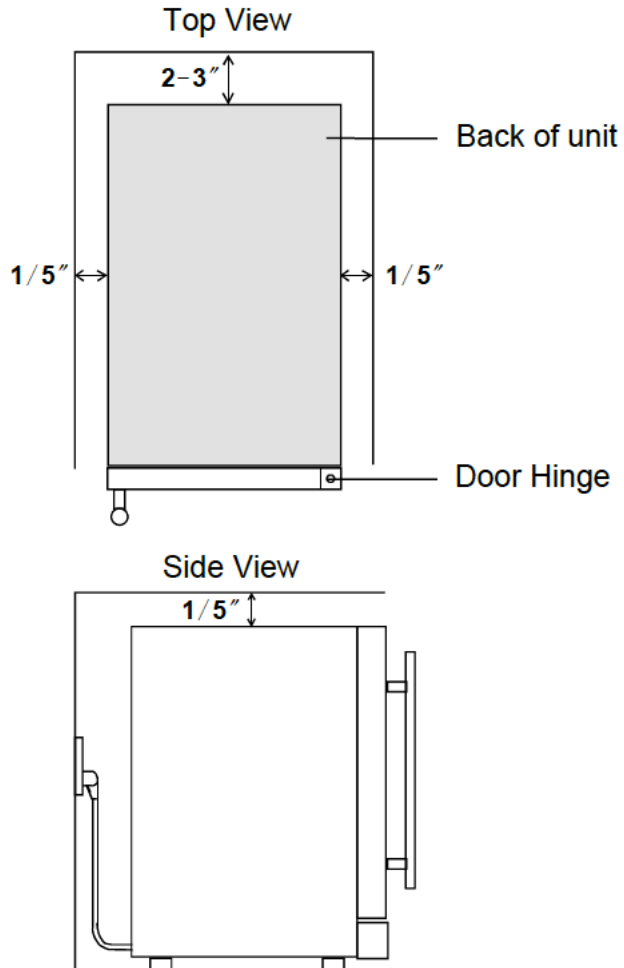

The installation should allow adequate space for the unit to be pulled forward for servicing.

The appliance should be placed on a firm and level surface and be able to support the weight when the unit is fully loaded.

The appliance must be leveled in order to work properly. The feet of the appliance can be rotated to level and adjust the height of the unit. Please refer to the "Leveling the Unit" section for more details.

Please ensure that a standard electrical supply (115 VAC only, 60 Hz) is properly grounded in accordance with National Electrical Code and local codes and ordinances.

Electrical Requirements

WARNING - ELECTRICAL SHOCK HAZARD!



- **ALWAYS** plug into a grounded 3-prong outlet.
- **NEVER** remove the grounding prong from the plug
- **NEVER** use an adapter to bypass the grounding prong
- **DO NOT** use an extension cord
- **Failure to follow these instructions can result in fire, electrical shock, or personal injury.**

Please make sure you have the following:

1. Proper electrical connection before you move your appliance into its final location.
2. A standard electrical supply (115 V, 60Hz), properly grounded in accordance with the National Electrical Code and local codes and ordinances.
3. A separate circuit, serving only your appliance is highly recommended. Use receptacles that cannot be turned off by a switch or pull chain.
4. The fuse (or circuit breaker) rating should be 3 Amps.
5. It is very important to have the appliance properly grounded to minimize possible shock hazard. The following grounding method must be strictly observed:
 - The appliance is equipped with a power supply cord having a 3-prong grounding plug and must be properly grounded.
 - The cord must be plugged into a mating 3-pronged wall socket and grounded in accordance with the National Electrical Code and local codes and ordinances.
 - If a mating wall socket is not available, please ensure to have a properly grounded 3-prong wall receptacle installed by a qualified electrician.

Leveling the Unit

IMPORTANT:

Regardless of which type of installation you choose, the appliance must be properly leveled in order to work properly.

The feet at the bottom of the unit can be raised or lowered individually by rotating the plastic sheaths around each of the feet. Rotate the feet until the appliance becomes level. Use a carpenter's leveling tool to verify the leveling. You may need to make several adjustments to level the unit.

Place a carpenter's level on top of the product to see if the appliance is level from front to back and side to side.

To adjust the height of the feet:

1. Turn the leveling feet to the right to lower that side of the unit.
2. Turn the leveling feet to the left to raise that side of the unit.

Installing the Door Handle and Shelves

THE DOOR HANDLE:

1. Open the door, carefully pull the door gasket around the area where the handle is to be installed, and remove the two pre-installed decorative plugs from the front of the door. (*Note: some models do not have decorative plugs installed.*)
2. Insert the Phillips head screws through the gasket side of the door and pass through the door.
3. Align the handle with the screws and hand-tighten using a Phillips head screwdriver until the handle is flush against the door frame. (*CAUTION: Do not over-tighten the screws as this may cause damage to the handle or to the stainless-steel door.*)
4. Carefully press the door gasket back into its original position.

THE SHELVES:

TS-CBWC6021DZ is equipped with glass shelves and slide out wire shelves.

To install:

- Open the door completely - make sure to open the door all the way before pulling the shelves out of their track to prevent damaging the door gasket.
- Slide the shelf on the shelf track and gently push back until it stops.
- Insert the glass shelf/wire shelf in a 30-degree angle, push all the way back. Level and place on rail gently.

To remove slide out shelves

- Open the door completely- make sure to open the door all the way before pulling the shelves out of their track to prevent damaging the door gasket.
- Remove all the contents sitting on the shelf, if any.
- Tilt one side of the shelf up at a 30-degree angle.
- Then proceed to pull out the shelf slowly.

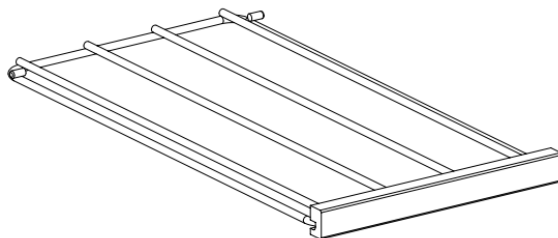

To remove Glass shelves

- Open the door all the way before pulling the shelves out of their track to prevent damaging the door gasket.
- Remove all the contents sitting on the shelf, if any.
- Tilt one side of the shelf up at a 30-degree angle.
- Then proceed to pull out the shelf slowly.

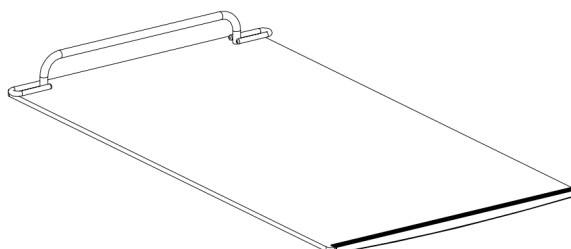

Operation

CHECK POINTS BEFORE OPERATION:

- Have you removed all packing materials and tape from the interior and exterior of the unit?
- Have you installed the unit properly by following the installation instructions?
- Has the unit been properly connected to the electrical outlet including proper grounding?
- Have you leveled the unit?
- Is the appliance properly located in an area where the ambient temperature is between 50°F and 95°F all year round?
- Is the clearance of the unit, at least 2 to 3 inches at the rear provided for proper air circulation?

THE CONTROL PANEL





This unit has a dual-zone temperature setting, the temperature ranges are:

Left Compartment: 38°F~65°F (3~18°C)

Right Compartment: 38°F~65°F (3~18°C)

BUTTONS

 **Power Button:** Press and hold for three seconds to power on the unit. Once pressed the “Power” indicator light will lit up to indicate the unit is running. Press and hold the button for three seconds again, the unit will power off and the “Power” Indicator light will turn off.

 **Energy conservation button:** Press and hold for three seconds to turn the energy conservation mode ON/OFF. When this mode is turned on, the LED light and display will be turned off and the °C/°F light will be on.

 **Light Switch:** Press this button to turn on/ off the interior LED light.

 **Increase Temperature:** To adjust the temperature, press button to increase the temperature by 1 degree increments.

 **Lower Zone Temperature:** To adjust the temperature of the lower zone, press button to lower the temperature by 1 degree increments.

°C/°F This unit can be displayed in Fahrenheit or Celsius. Press this button to change the setting.

INDICATOR LIGHTS AND DISPLAYS



The unit is in cooling mode when this light is on.

°C °F



Displays the set temperature of the compartment.

Temperature Memory

This appliance has a temperature memory function. The temperature setting is automatically save. In case of a power outage, the temperature setting will remain when power resumes.

Temperature Alarm

When the unit's interior temperature is higher than 73°F (23°C), "HI" will display on the panel and a buzzing alarm sound will go off. When the interior temperature is lower than 32°F (0°C), "LO" will display on the panel, the alarm and the malfunction indicator light will go off at the same time. In either case, immediate attention is advised.

DOOR ALARM

This unit is equipped with an audible alarm to alert you when the door has been left open. If at any time the door has been left open for more than 5 minutes at a time, the alarm will sound and it will continue to sound until the door is closed completely or the unit is powered off.

Note:

1. Run the unit for at least 24 hours before storing your wines/beverages to allow the temperature to stabilize.
2. Please wait at least 5 minutes in between before turning the power off and back on.
3. The ambient environmental conditions determine whether your unit can reach the actual set temperature.
4. There is a temperature allowance of +/- 2 degrees Celsius.

Storage

Wine bottles vary in size and dimensions. Titan wine cooler is crafted with professional wine enthusiasts and collectors who have sophisticated and diverse tastes in mind. Titan's racks are designed to comfortably hold standard 750ml bottles without scratching the labels. The loading capacities include the following listed wine bottles.

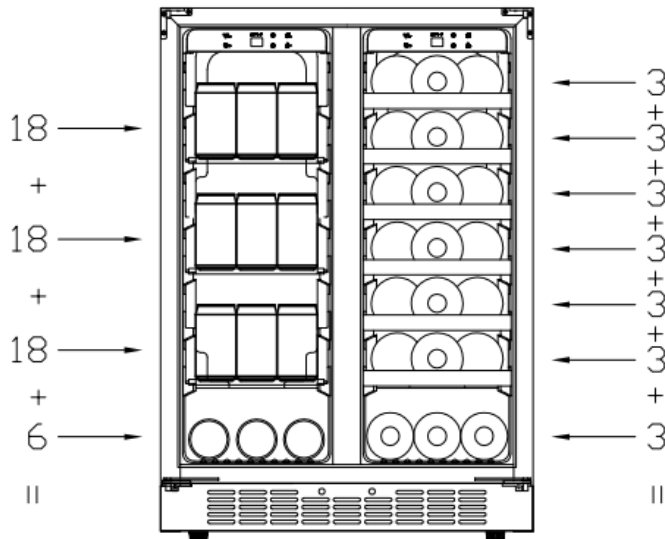

Total 60 cans(max)
beverage

Total 21 bottles

Sounds

Some sounds and noises generated by this appliance may not be common to you, however most of these sounds are normal. Hard surfaces like floor and walls may make the sounds seem louder than they actually are.

The following are the sounds you may be experiencing and what's making them.

- Rattling sounds – These may come from the flow of the refrigerant or the water line. Make sure nothing is stored on top of the appliance as this may damage the appliance and also create rattling sounds.
- High-pitched sound – These may come from the efficient compressor.
- Splashing sound – Water running from the evaporator to the water bin.
- Gurgling sound -- May be generated due to the refrigerant flowing in the unit.
- Fan noise – From the condenser fan circulate air within the unit.

Defrosting

The unit automatically defrosts under most ambient conditions and refrigerating settings. However some frost may build up under colder settings. Additionally, frost may also build up under more humid ambient conditions. Keep the door closed as much as possible and avoid opening the door unnecessarily to minimize frost build-up.

If frost prevents the door from closing properly, power the unit off until the frost melts. Use a soft absorbent towel to dry the unit.

WARNING:

NEVER attempt to remove frost with sharp objects. This may damage the appliance.

Preparation the Unit for Storage

If the appliance is not to be used for a long time, or will be moving to another place, please ensure to defrost the unit and dry the interior:

1. Disconnect the appliance from the power supply, unplugging the power from the wall socket.
2. Open the door to allow air to circulate to prevent mold, mildew and unpleasant smells to built up inside the unit.

IMPORTANT: Keep the unit out of the reach of children. Take additional precautions by removing the door to prevent a child from being trapped inside the unit if necessary.

WARNING:

NEVER touches the electrical plug with wet hands.

NEVER unplug the unit by pulling the electrical cord.

Cleaning, Care and Maintenance

Proper maintenance and periodical cleaning will preserve high efficiency, peak performance, and long life of the unit.

EXTERIOR CLEANING

1. Door and cabinet - a mild detergent and lukewarm water solution such as 2 tablespoons of baking soda to 1 quart of water.
2. If the door panel is stainless steel, clean with a cloth dampened with a mild detergent and warm water solution.
3. Use a soft sponge and rinse with clean water.
4. Wipe with a soft clean towel to prevent water spotting.

IMPORTANT:

- **DO NOT** use solvent based or abrasive cleaners.
- **NEVER** use an abrasive or caustic cleaning agent. Stainless Steel can discolor when exposed to chlorine gas and moisture.

INTERIOR CLEANING

1. Turn the unit off and disconnect from power supply.
2. Open the door and remove contents and shelves.
3. Wait until the unit defrosts.
4. Wipe the interior of the unit with a clean cloth.
5. Reinsert shelves and beverages.
6. Reconnect power to the unit.

Energy Saving Tips

- ◆ Ensure the unit is adequately ventilated and is located in the coolest area of the room.
- ◆ The appliance should be placed away from heat producing appliances, and out of any direct sunlight.
- ◆ Never obstruct the air vents.
- ◆ Close the door tightly and do not open the appliance too frequently or for a long period of time.
- ◆ Do not overload the appliance to allow air to circulate

Trouble Shooting

PROBLEM	POSSIBLE CAUSE	SOLUTION
The appliance does not turn on.	<ul style="list-style-type: none"> • There is a power failure. • The unit is not plugged in. • A house fuse has blown or the circuit breaker is tripped. 	<ul style="list-style-type: none"> • Ensure the power outlet has power. • Check and plug the unit in to a power outlet that has sufficient amperage. • Replace the blown fuse or reset the breaker.
The appliance turns on and off frequently.	<ul style="list-style-type: none"> • The ambient temperature is too high. • The door is being opened too often. • The door is not closed properly. • The door gasket is not sealing properly. • Inadequate ventilation around the unit. 	<ul style="list-style-type: none"> • Run the appliance at the appropriate recommended ambient temperature. • Avoid opening the door too frequently. • Make sure the door is closed properly. • Make sure the door gasket is properly sealed. • Read and observe the 'Clearance Requirements' section of this owner's manual
The appliance does not reach the desired temperature/The appliance is not cold enough.	<ul style="list-style-type: none"> • The unit is installed too close to heat source(s). • Inadequate ventilation around and behind the unit. • The door is opened too frequently or for long periods of time. 	<ul style="list-style-type: none"> • Keep the unit away from heat sources, e.g. direct sunlight. • Read and follow the 'Installation Clearance Requirements' section of this manual. • Close the door tightly and do not open the door too frequently or for long periods of time.
The appliance is making strange sounds.	<ul style="list-style-type: none"> • Some sounds are normal. • The unit is not properly leveled. • The unit is touching another appliance. 	<ul style="list-style-type: none"> • Read the 'Sounds' section. • Check to make sure that the unit is leveled. • Ensure the unit is not touching another appliance or furniture.
The body of the appliance is electrified.	<ul style="list-style-type: none"> • The unit is not properly grounded. 	<ul style="list-style-type: none"> • Contact your local electrician to test your electrical grounding system.
Frost is forming in the appliance.	<ul style="list-style-type: none"> • The environment is too humid. • The ambient temperature is too low. • The door is opened too frequently. 	<ul style="list-style-type: none"> • This unit has an 'auto-defrost' system, however, manual defrosting may still be required under some conditions. If frost builds up, try running the cooler at a warmer temperature setting, minimizing the number of door openings, or unplug the unit to defrost.
The door does not shut properly.	<ul style="list-style-type: none"> • The unit is not leveled properly. • The door gasket is dirty. • The door gasket is not installed incorrectly. • The shelves are incorrectly installed. 	<ul style="list-style-type: none"> • Make sure the cooler is properly leveled before operating. • Clean the door gasket. • Make sure the door gasket is properly installed. • Make sure the shelves are installed correctly – refer to 'Installing the Door Handle and Shelf' Section of this manual.

Specifications

MODEL	TS-CBWC6021DZ
VOLTAGE	115V/60Hz
AMPS	1.5A
INPUT POWER	130W
CAPACITY	60Cans+21bottles
POWER CORD LENGTH	5.23ft
TEMPERATURE RANGE	38 to 65 °F
WEIGHT	131lbs
DIMENSIONS Including handle	34.1H x 25.4D x 23.8W"

Features

- Stainless steel door with clear glass
- Stainless steel towel bar handles
- Built-in or freestanding application
- Two (2) independently controlled zones
- Digital temperature controls w/ LED display
- Powerful compressor cooling
- Blue interior LED lighting
- Auto defrost
- Integrated safety lock
- Three (3) pull out silver trimmed glass shelves
- Six (6) pull out stainless steel trimmed wire shelves
- Internal fan evenly circulates air & temperature
- Built in replaceable carbon filter
- ETL approved

NOTE:

Technical data and performance information is for reference only.
Specifications are subject to change without prior notice. Please refer to the rating label on the appliance for the most accurate information.

PRODUCT WARRANTY

ONE YEAR LIMITED WARRANTY

THIS WARRANTY COVERS:

- The original purchaser within all states in the continental United States (excluding Hawaii and Alaska) for one year from the date of purchase against defects in materials and workmanship under normal use and service.
- Titan will be responsible for all transportation costs incurred in the event that service under this warranty is needed for the first 3 months from original purchase date. Consumer will be responsible for freight cost to Titan's service department after 3 months to one year.
- Titan will repair or replace any parts found defective with new, rebuilt, or refurbished parts free of charge.
- Titan reserves the right to request a defective part be returned in exchange for the replacement part.
- After the one year limited warranty, any labor charges or replacement parts will be the responsibility of the original owner of the unit.
- This warranty is not transferable.

THIS WARRANTY DOES NOT COVER:

- Shipping damage and any damage caused by improper packaging for shipment to Titan.
- Cosmetic damage such as scratches and dents or other appearance parts by wear and tear.
- Damage not caused by a defect in material or workmanship while in the possession of a consumer.
- Damage caused by consumer misuse, abuse, tampering, or failure to follow the care and special handling instructions provided in the owner's manual.
- Damage caused by improper installation, maintenance negligence, commercial use, repairs or alterations to the product by anyone not authorized by the manufacturer.
- Acts of God, such as fire, flood, hurricanes, earthquakes and tornadoes.
- Products sold AS Is or from an unauthorized seller.
- Freight and Insurance cost for the warranty service.

Obtaining Warranty Service:

Contact Titan Customer Service at service@titan-appliances.com for troubleshooting, assistance and warranty service. You are required to have your model number, serial number and proof of purchase before contacting Customer Service. Once a Titan Customer Service Representative has confirmed that your product is eligible for warranty service, the product must be returned to an authorized repair center. The returned product must be packaged carefully in its original packaging with the original box and packaging material to avoid shipping damages. Titan is not responsible for damage resulting from mishandling or improper packaging. Do not return a defective product to the place of purchase.

Products received without a return authorization number will be refused.

DISCLAIMER OF IMPLIED WARRANTIES; LIMITATION OF REMEDIES

CUSTOMER'S SOLE AND EXCLUSIVE REMEDY UNDER THIS LIMITED WARRANTY SHALL BE PRODUCT REPAIR OR REPLACEMENT AS PROVIDED HEREIN. IMPLIED WARRANTIES INCLUDING WARRANTIES OF MERCHANTABILITY OR FITNESS FOR A PARTICULAR PURPOSE, ARE LIMITED TO ONE YEAR. WARRANTOR SHALL NOT BE LIABLE FOR CONSEQUENTIAL OR INCIDENTAL DAMAGES SUCH AS PROPERTY DAMAGE AND INCIDENTAL EXPENSES RESULTING FROM ANY BREACH OF THIS WRITTEN LIMITED WARRANTY OR ANY IMPLIED WARRANTY. SOME STATES AND PROVINCES DO NOT ALLOW THE EXCLUSION OR LIMITATION OF INCIDENTAL OR CONSEQUENTIAL DAMAGES, OR LIMITATIONS ON THE DURATION OF IMPLIED WARRANTIES, SO THESE LIMITATIONS OR EXCLUSIONS MAY NOT APPLY TO YOU. THIS WRITTEN WARRANTY GIVES YOU SPECIFIC LEGAL RIGHTS. YOU MAY ALSO HAVE OTHER RIGHTS THAT VARY FROM STATE TO STATE.