

11. Installation Instruction

11.1 Select the Best Location

11.1.1 Indoor Unit

- Do not install the unit in excessive oil fume area such as kitchens, workshops and etc.
- There should not be any heat source or steam near the unit.
- There should not be any obstacles blocking the air circulation.
- A place where air circulation in the room is good.
- A place where drainage can be easily done.
- A place where noise prevention is taken into consideration.
- Do not install the unit near the door way.
- Ensure the spaces indicated by arrows from the wall, ceiling, fence or other obstacles.
- Recommended installation height for indoor unit shall be at least 8.2 ft.

11.1.2 Outdoor Unit

- If an awning is built over the unit to prevent direct sunlight or rain, be careful that heat radiation from the condenser is not obstructed.
- There should not be any animal or plant which could be affected by hot air discharged.
- Keep the spaces indicated by arrows from wall, ceiling, fence or other obstacles.
- Do not place any obstacles which may cause a short circuit of the discharged air.
- If piping length is over the [piping length for additional gas], additional refrigerant should be added as shown in the table.
- Recommended installation height for outdoor unit should be above the seasonal snow level.

Model	Capacity (Btu/h)	Piping size		Std. Length (ft)	Max. Elevation (ft)	Min. Piping Length (ft)	Max. Piping Length (ft)	Additional Refrigerant (oz/ft)	Piping Length for add. gas (ft)
		Gas	Liquid						
E18NKUA	17100	1/2"	1/4"	24.6	49.2	9.8	100.0	0.3	32.8
E24NKUA	24000	5/8"							

Example: For E18NKUA

If the unit is installed at 41 ft distance, the quantity of additional refrigerant should be 2.46 oz

$$(41 - 32.8) \text{ ft} \times 0.3 \text{ oz/ft} = 2.46 \text{ oz.}$$

11.2 Indoor/Outdoor Unit Installation Diagram

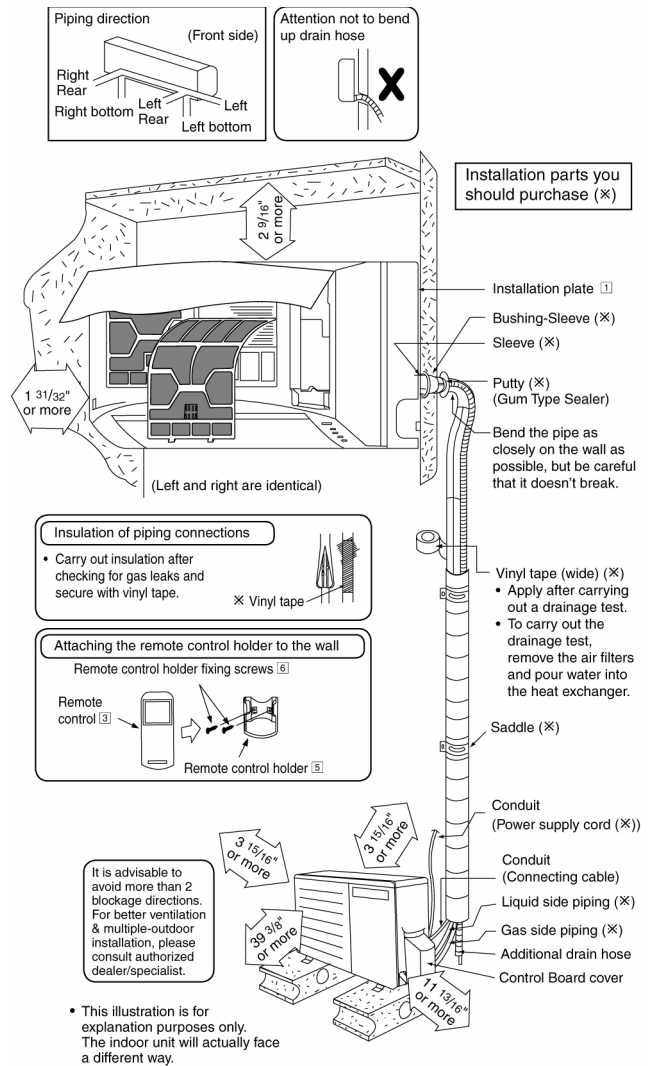

11.3 Indoor Unit

11.3.1 How to Fix Installation Plate

The mounting wall must be strong and solid enough to prevent it from the vibration.

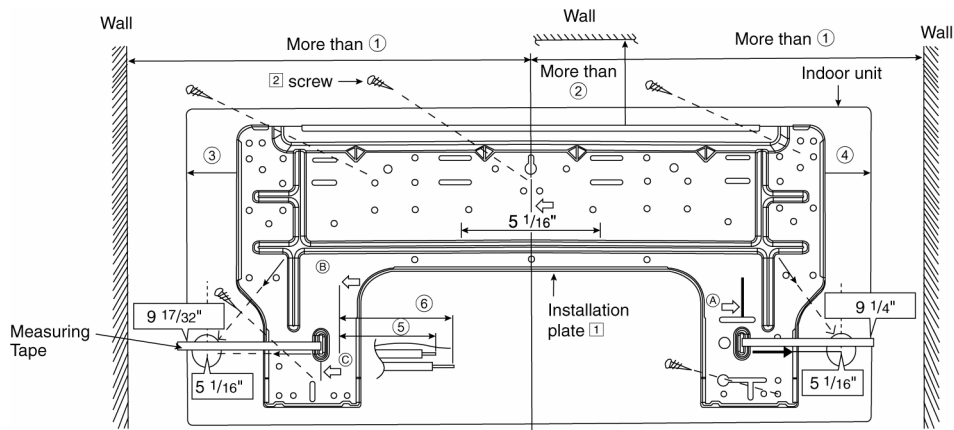

Model	Dimension					
	①	②	③	④	⑤	⑥
E18NKUA, E24NKUA	23 1/32"	3 7/32"	6 1/2"	6 7/32"	6 21/32"	8 5/8"

The center of installation plate should be at more than ① at right and left of the wall.

The distance from installation plate edge to ceiling should more than ②.

From installation plate left edge to unit's left side is ③.

From installation plate right edge to unit's right side is ④.

- Ⓑ : For left side piping, piping connection for liquid should be about ⑤ from this line.
 : For left side piping, piping connection for gas should be about ⑥ from this line.

- Mount the installation plate on the wall with 5 screws or more (at least 5 screws).
 (If mounting the unit on the concrete wall, consider using anchor bolts.)
 - Always mount the installation plate horizontally by aligning the marking-off line with the thread and using a level gauge.
- Drill the piping plate hole with $\varnothing 2\text{-}3/4\text{'}$ hole-core drill.
 - Line according to the left and right side of the installation plate. The meeting point of the extended line is the center of the hole. Another method is by putting measuring tape at position as shown in the diagram above. The hole center is obtained by measuring the distance namely $5\text{-}1/16\text{'}$ for left and right hole respectively.
 - Drill the piping hole at either the right or the left and the hole should be slightly slanting to the outdoor side.

11.3.2 To Drill a Hole in the Wall and Install a Sleeve of Piping

- Insert the piping sleeve to the hole.
- Fix the bushing to the sleeve.
- Cut the sleeve until it extrudes about $19/32\text{'}$ from the wall.

⚠ CAUTION

When the wall is hollow, please be sure to use the sleeve for tube assembly to prevent dangers caused by mice biting the connecting cable.

- Finish by sealing the sleeve with putty or caulking compound at the final stage.

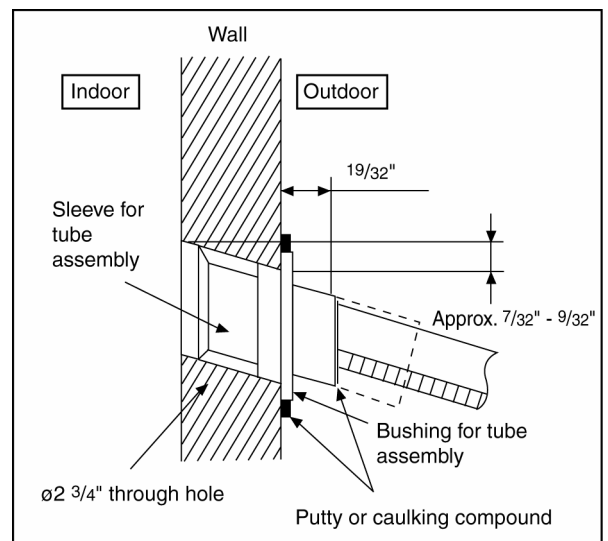

11.3.3 Indoor Unit Installation

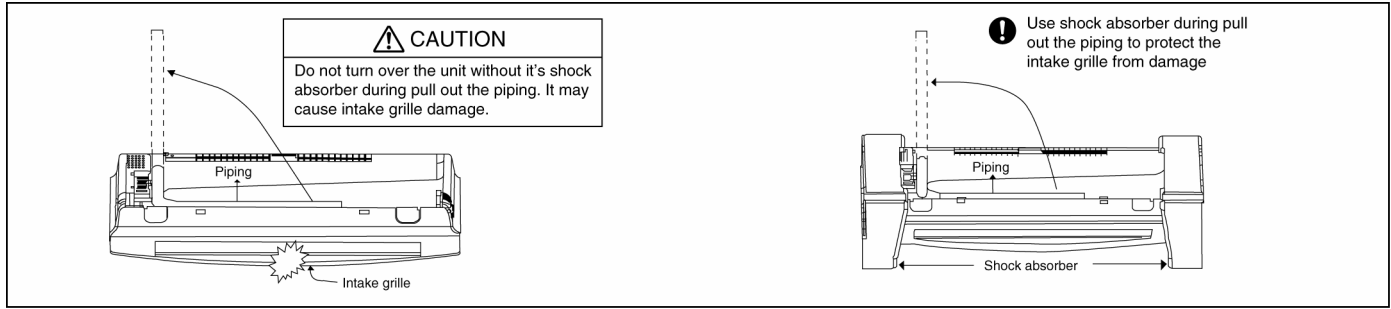

11.3.4 For the right rear piping

- Step-1 Pull out the Indoor piping
- Step-2 Install the Indoor Unit
- Step-3 Secure the Indoor Unit
- Step-4 Insert the connecting cable

11.3.5 For the right bottom piping

- Step-1 Pull out the Indoor piping
- Step-2 Install the Indoor Unit
- Step-3 Insert the connecting cable
- Step-4 Secure the Indoor Unit

11.3.6 For the embedded piping

- Step-1 Replace the drain hose
- Step-2 Bend the embedded piping
 - Use a spring bender or equivalent to bend the piping so that the piping is not crushed.
- Step-3 Pull the connecting cable into Indoor Unit
 - The inside and outside connecting cable can be connected without removing the front grille.
- Step-4 Cut and flare the embedded piping
 - When determining the dimensions of the piping, slide the unit all the way to the left on the installation plate.
 - Refer to the section "Cutting and flaring the piping".
- Step-5 Install the Indoor Unit
- Step-6 Connect the piping
 - Please refer to "Connecting the piping" column in outdoor unit section. (Below steps are done after connecting the outdoor piping and gas-leakage confirmation.)
- Step-7 Insulate and finish the piping
 - Please refer to "Piping and finishing" column of outdoor section and "Insulation of piping connection" column as mentioned in indoor/outdoor unit installation.
- Step-8 Secure the Indoor Unit

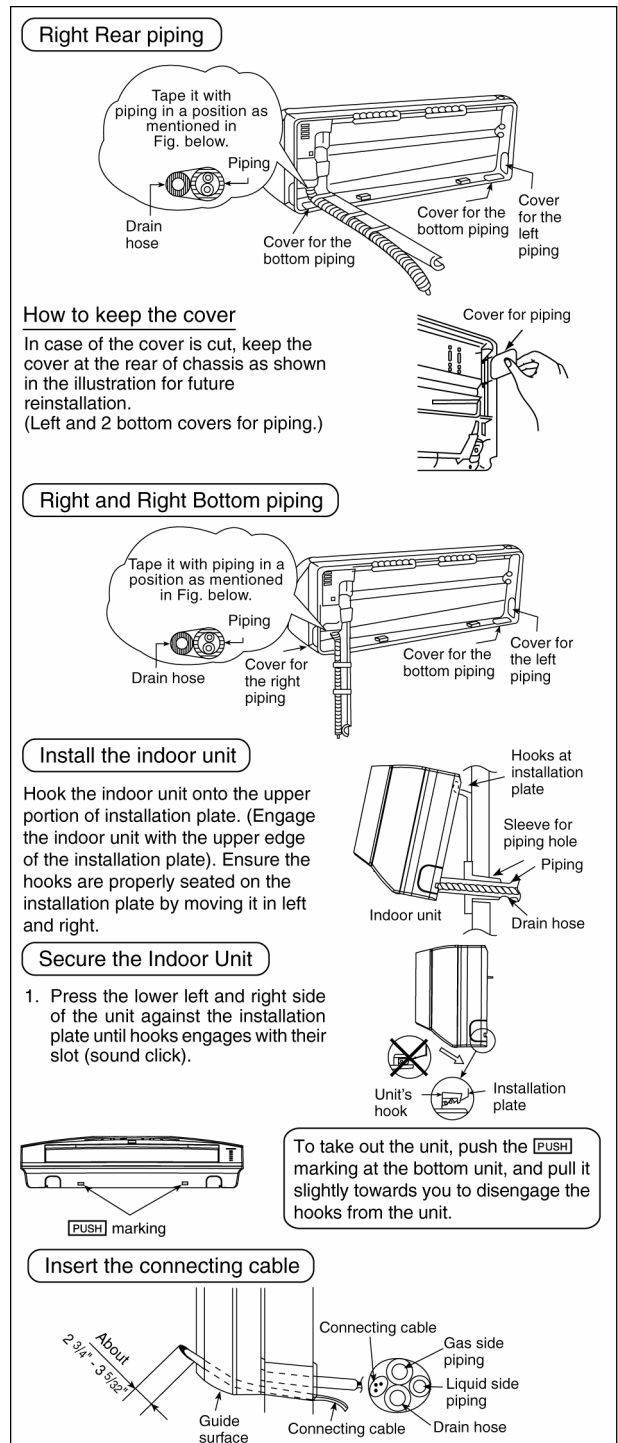

(This can be used for left rear piping and bottom piping also.)

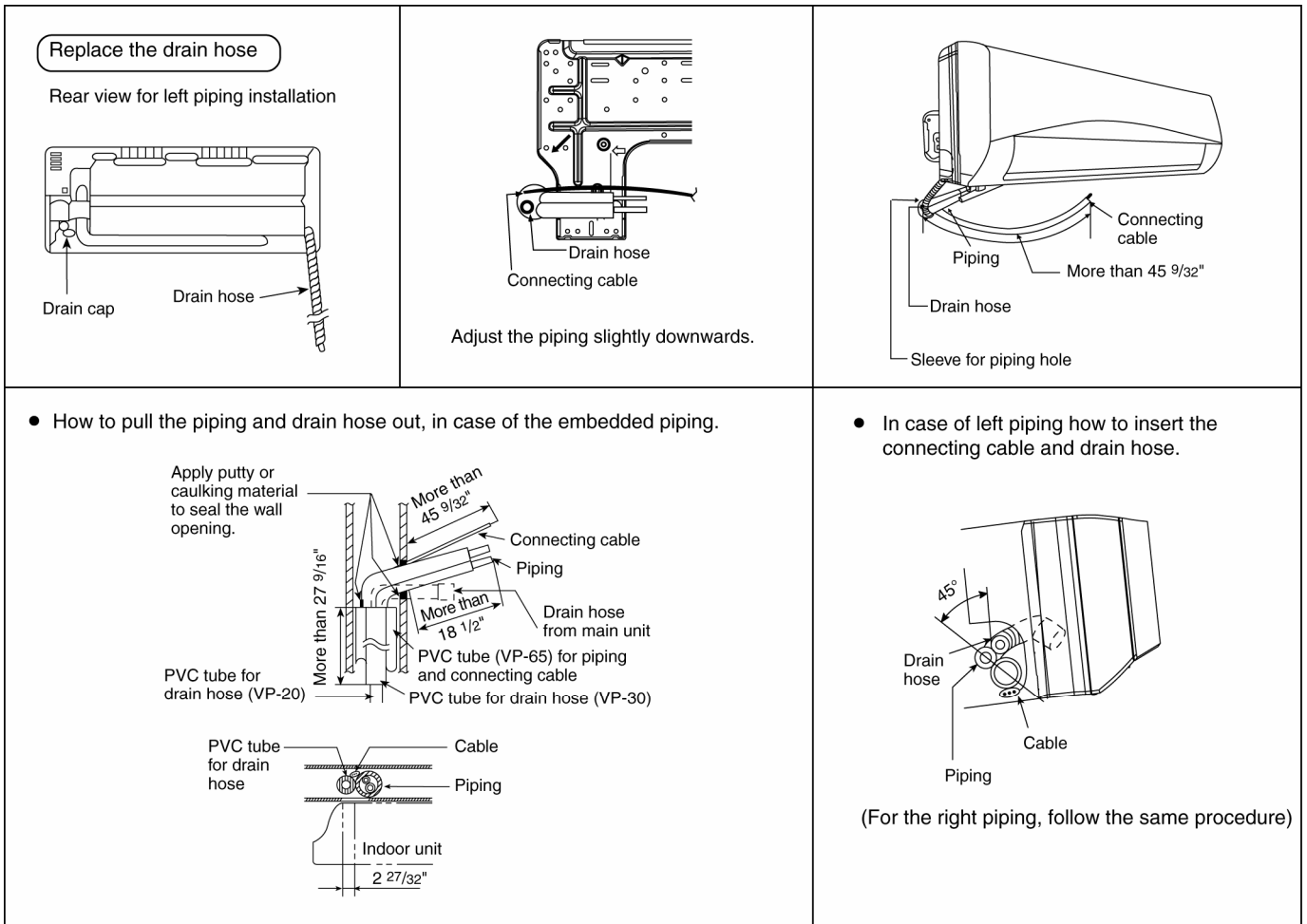

11.3.7 Connect the Cable to the Indoor Unit

- The inside and outside connecting cable can be connected without removing the front grille.
- Unscrew the conduit cover and fix the conduit connector to conduit cover with lock nut, then secure it against chassis.
- Connecting wire between indoor unit and outdoor unit should be UL listed or CSA approved 4 conductor wires minimum AWG16 in accordance with local electric codes.
 - Ensure the colour of wires of outdoor unit and terminal number are the same as the indoor's respectively.

Terminals on the indoor unit	1	2	3	
Colour of wires (connecting wire)				
Terminals on the outdoor unit	1	2	3	

- This equipment must be properly earthed.
 - Earth lead wire shall be Yellow/Green (Y/G) in colour and shall be longer than other lead wires as shown in the figure for electrical safety in case of the slipping.

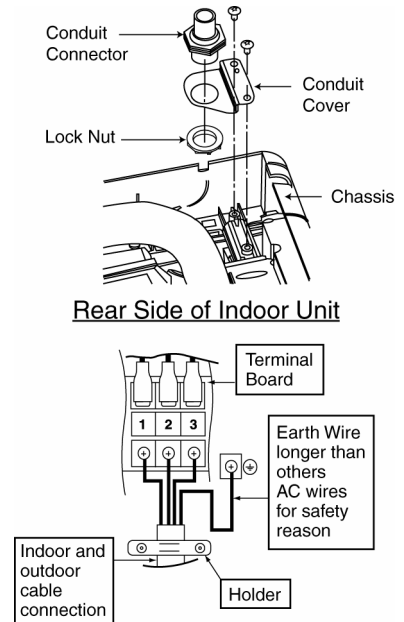

11.3.8 Wiring Stripping and connecting requirement

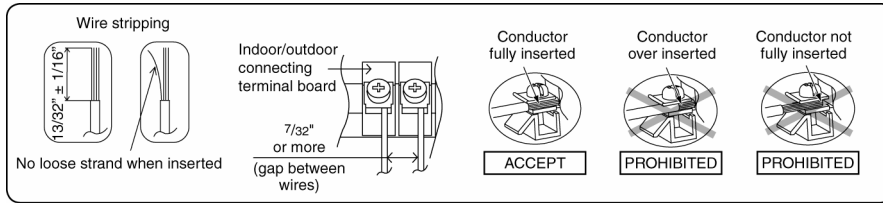

11.3.9 Cutting and flaring the piping

- 1 Please cut using pipe cutter and then remove the burrs.
- 2 Remove the burrs by using reamer. If burrs are not removed, gas leakage may be caused. Turn the piping end down to avoid the metal powder entering the pipe.
- 3 Please make flare after inserting the flare nut onto the copper pipes.

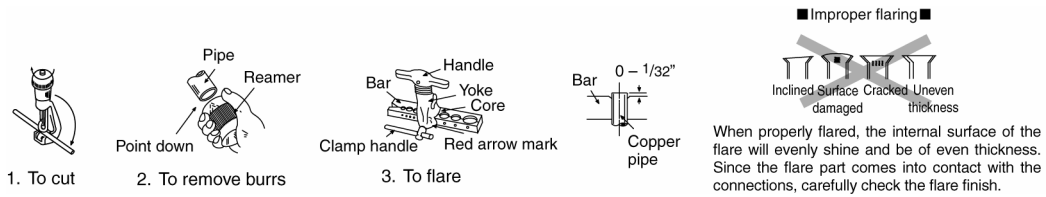

11.4 Outdoor Unit

11.4.1 Install the Outdoor Unit

- After selecting the best location, start installation according to indoor/outdoor unit installation diagram.
 - Fix the unit on concrete or rigid frame firmly and horizontally by bolt nut ($\phi 13/32$).
 - When installing at roof, please consider strong wind and earthquake.
Please fasten the installation stand firmly with bolt or nails.

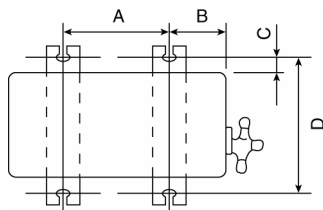

Model	A	B	C	D
E18NKUA, E24NKUA	24-1/8"	5-5/32"	5/8"	14-3/16"

11.4.2 Connect the Piping

11.4.2.1 Connecting the piping to indoor

Please make flare after inserting flare nut (locate at joint portion of tube assembly) onto the copper pipe. (In case of using long piping)

Connect the piping

- Align the center of piping and sufficiently tighten the flare nut with fingers.
- Further tighten the flare nut with torque wrench in specified torque as stated in the table.

11.4.2.2 Connecting the piping to outdoor

Decide piping length and then cut by using pipe cutter. Remove burrs from cut edge.

Make flare after inserting the flare nut (locate at valve) onto the copper pipe.

Align center of piping to valves and then tighten with torque wrench to the specified torque as stated in the table.

11.4.2.3 Gas Leak Checking

Pressure test to system to 400 PSIG with dry nitrogen, in stages. Thoroughly leak check the system. If the pressure holds, release the nitrogen and proceed to section 4.

Do not over tighten, over tightening may cause gas leakage.

Piping size	Torque
1/4"	13.3 lbf.ft
3/8"	31.0 lbf.ft
1/2"	40.6 lbf.ft
5/8"	47.9 lbf.ft
3/4"	73.8 lbf.ft

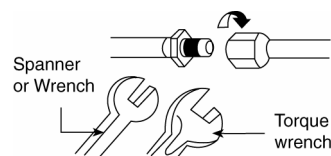

11.4.3 Evacuation of the equipment

WHEN INSTALLING AN AIR CONDITIONER, BE SURE TO EVACUATE THE AIR INSIDE THE INDOOR UNIT AND PIPES in the following procedures.

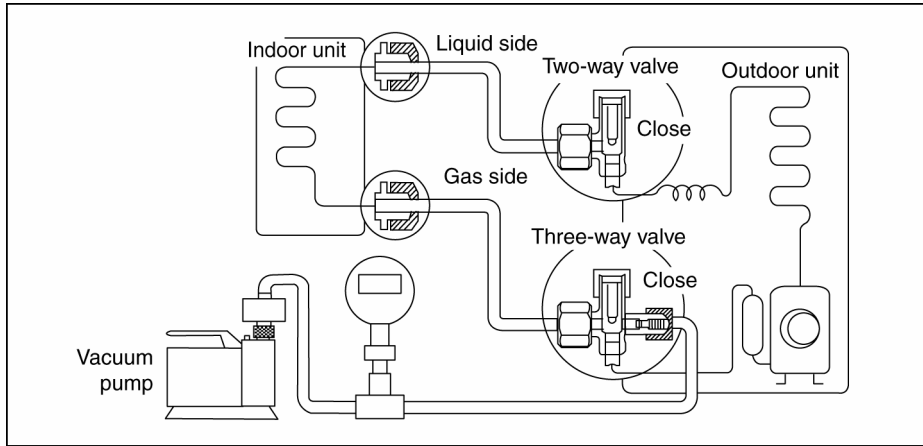

1. Connect a charging hose with a push pin to the Low side of a charging set and the service port of the 3-way valve.
2. Connect the micron gauge between vacuum pump and service port of outdoor units.
3. Turn on the power switch of the vacuum pump and make sure that connect digital micron gauge and to pull down to a value of 500 microns.
4. To make sure micron gauge a value 500 microns and close the low side valve of the charging set and turn off the vacuum pump.
5. Disconnect the vacuum pump house from the service port of the 3-way valve.
6. Tighten the service port caps of the 3-way valve at a torque of 13.3 lbf.ft with a torque wrench.
7. Remove the valve caps of both of the 2-way valve and 3-way valve. Position both of the valves to "Open" using a hexagonal wrench (5/32").
8. Mount valve caps onto the 2-way valve and the 3-way valve.
 - o Be sure to check for gas leakage.

CAUTION

- If micron gauge value does not descend 500 microns, take the following measures:
 - If the leak stops when the piping connections are tightened further, continue working from step ③.
 - If the leak does not stop when the connections are retightened, repair location of leak.
 - Do not release refrigerant during piping work for installation and reinstallation.
 - Be careful with the liquid refrigerant, it may cause frostbite.

11.4.4 Connect the Cable to the Outdoor Unit

1. Remove control board cover (Resin and Metal).
2. Remove particular plate.
3. Remove plugs.
4. Fix the conduit connectors to the knockout holes with lock-nuts, then secure them against the side panel.
5. All wires pass through conduits & particular plate's opening hole.
6. Connecting wire between indoor unit and outdoor unit should be UL listed or CSA approved 4 conductor wires minimum AWG16 in accordance with local electric codes.
7. Wire connection to the power supply (208/230V 60Hz) through circuit breaker.
 - o Connect the UL listed or CSA approved wires minimum AWG12 to the terminal board, and connect the other end of the wires to ELCB / GFCI.
8. Connect the power supply cord and connecting wire between indoor unit and outdoor unit according to the diagram below.

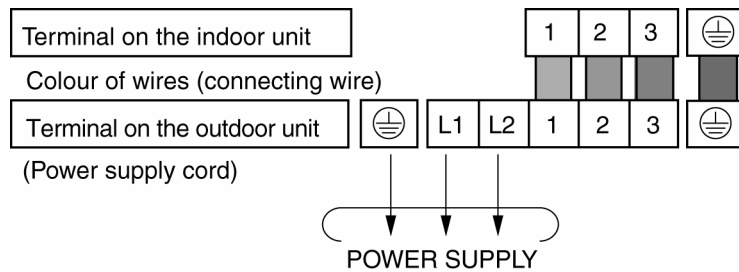

9. Secure the wire onto the control board with the holder (clammer).
 10. After completing wiring connections, reattach the particular plate control board cover (metal and resin) and the original position with the screws.
 11. For wire stripping and connection requirement, refer to instruction 11.3.7 of indoor unit.
- ⚠ This equipment must be properly earthed.
 - Earth lead wire shall be Yellow/Green (Y/G) in colour and longer than other lead wires as shown in the figure for electrical safety in case of the slipping.

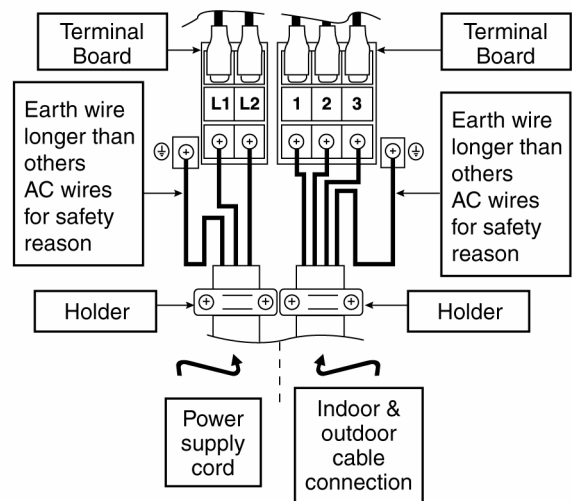
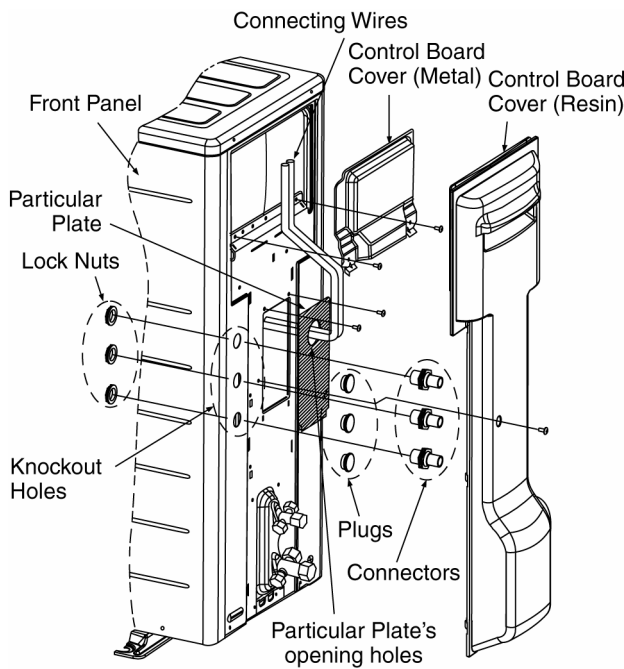

11.4.5 Piping Insulation

1. Please carry out insulation at pipe connection portion as mentioned in Indoor/Outdoor Unit Installation Diagram. Please wrap the insulated piping end to prevent water from going inside the piping.
2. If drain hose or connecting piping is in the room (where dew may form), please increase the insulation by using POLY-E-FOAM with thickness 1/4" or above.