

5. Refer to repair parts list below. Attach hitch bracket to drawbar with two 3/8" x 3/4" hex bolts and keps nuts as shown. Insert hitch pin and lock in place with hairpin provided.

REPAIR PARTS LIST

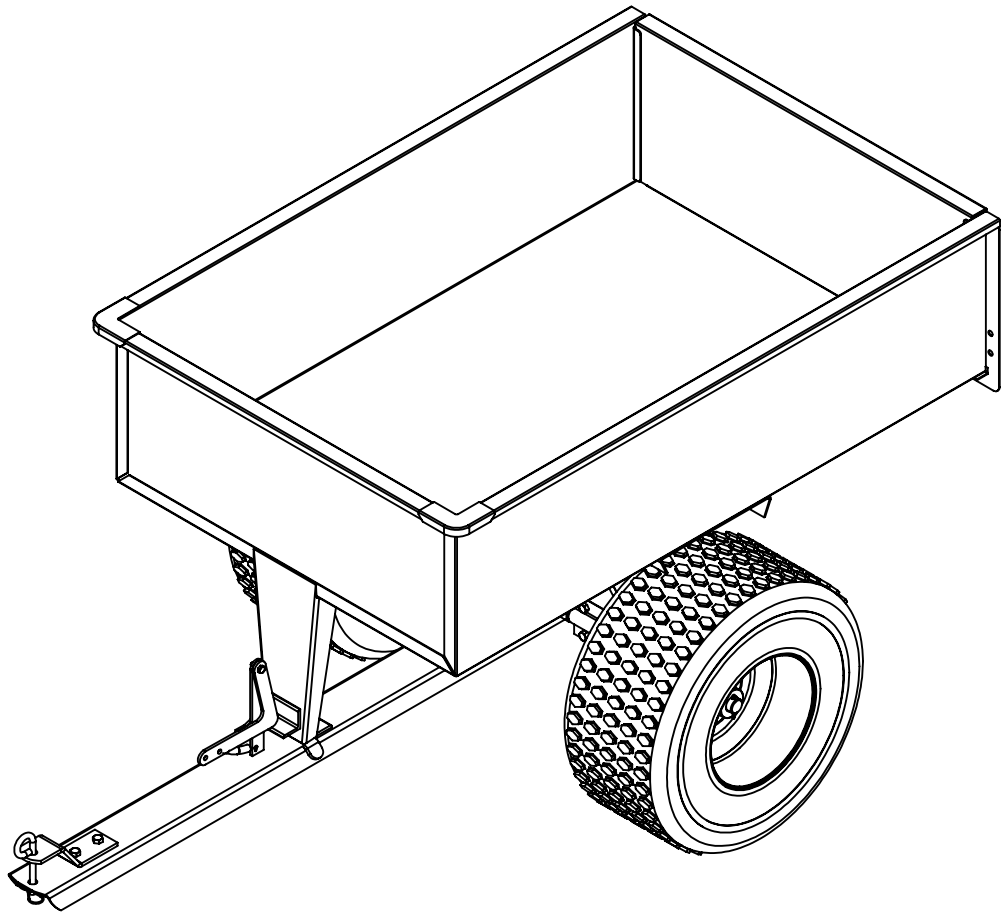
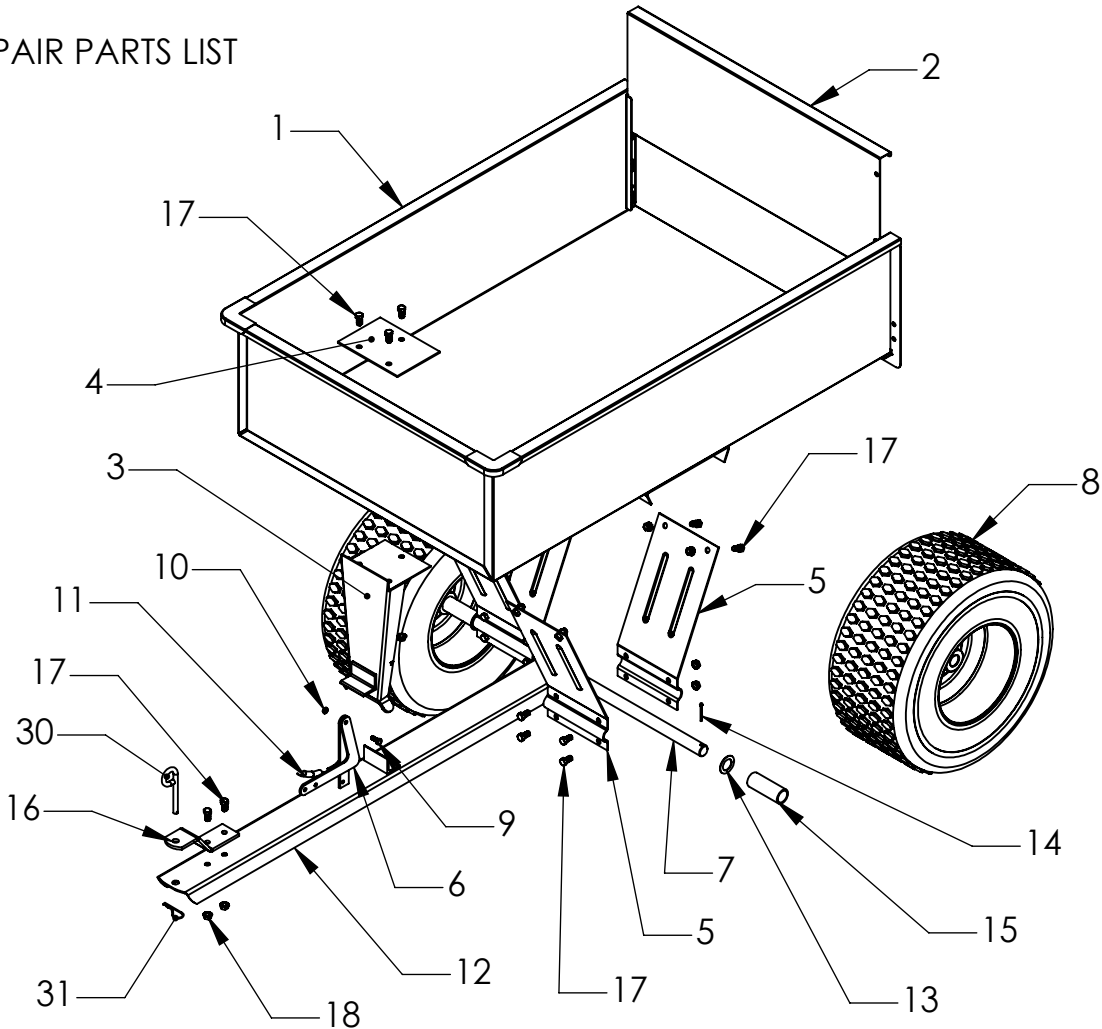

3460HATV
 20 CU. FT. HEAPED CAPACITY
 ALL TERRAIN CART
 ASSEMBLY MANUAL AND PARTS LIST

REF. NO.	PART NO.	QTY.	DESCRIPTION	REF. NO.	PART NO.	QTY.	DESCRIPTION
1	3460HATV-1	1	CART BODY	13	3460HATV-13	2	*1" DIA AXLE WASHER
2	3460HATV-2	1	TAILGATE	14	3460HATV-14	2	*COTTER PIN 1/8" X 1 1/2"
3	3460HATV-3	1	FRONT SUPPORT	15	3460HATV-15	2	AXLE SPACER 3 1/2"
4	3460HATV-4	1	FRONT SUPPORT PLATE	16	3460HATV-16	1	ATV HITCH BRACKET
5	3460HATV-5	4	AXLE HOLDER PLATE	17	3460HATV-17	21	*BOLT 3/8"-16 X 3/4" HEX
6	3460HATV-6	1	LATCH ARM	18	3460HATV-18	21	*NUT 3/8"-16 KEPS
7	3460HATV-7	1	AXLE 1" DIA.	30	3460HATV-30	1	HITCH PIN HP-3
8	3460HATV-8	2	ATV TIRE	31	3460HATV-31	1	*HAIR PIN COTTER #7
9	3460HATV-9	1	*BOLT 1/4" X 3/4" HEX				
10	3460HATV-10	1	*1/4" LOCK NUT				
11	3460HATV-11	1	LATCH SPRING	AM	3460HATV-AM	1	ASSEMBLY MANUAL
12	3460HATV-12	1	DRAWBAR	BB	3460HATV-BB	1	HARDWARE BAG

* denotes standard hardware item, can be purchased locally.

CAUTION:
 READ AND FOLLOW
 ALL SAFETY RULES
 AND INSTRUCTIONS
 BEFORE USING
 THIS EQUIPMENT.



2575 FERRIS ROAD
 COLUMBUS, OHIO 43224-2597

TOOLS REQUIRED

7/16" WRENCH AND SOCKET
 9/16" WRENCH AND SOCKET
 PLIERS

SAFETY INSTRUCTION

DO NOT CARRY PASSENGERS IN CART.
 DO NOT TOW CART ON PUBLIC ROADS.
 NEVER EXCEED LOAD CAPACITY - 1500LBS.
 AVOID SUDDEN TURNS OR MANEUVERS.
 WHEN OPERATING ON SLOPES, USE LOWEST
 GROUND SPEED AND LIMIT LOAD TO 200LBS.
 OPERATE UP AND DOWN SLOPES, NEVER
 ACROSS THE FACE.

MAINTENANCE

CHECK TIRE PRESSURE REGULARLY.
 PERIODICALLY CHECK ALL BOLTS.
 KEEP CART CLEAN TO PREVENT RUST.
 STORE INSIDE A CLEAN DRY AREA.

CARTON CONTENTS		
REF.NO.	QTY.	DESCRIPTION
1	1	CART BODY
2	1	TAIL GATE
3	1	FRONT SUPPORT
4	1	FRONT SUPPORT BACKING PLATE
5	4	AXLE HOLDER PLATES
6	1	LATCH ARM
7	1	AXLE
8	2	ATV TIRES
12	1	DRAWBAR ASSEMBLY
16	1	HITCH BRACKET
50	1	ASSEMBLY MANUAL
BB	1	HARDWARE BAG

BOLT BAG CONTENTS		
13	2	1" AXLE WASHERS
14	2	COTTER PINS 1/8" X 1 1/2"
15	2	AXLE SPACERS
17	21	3/8"-16 X 3/4" HEX HEAD BOLTS
18	21	3/8"-16 KEPS NUT
30	1	HITCH PIN
31	1	HAIR PIN COTTER

STEP 1.

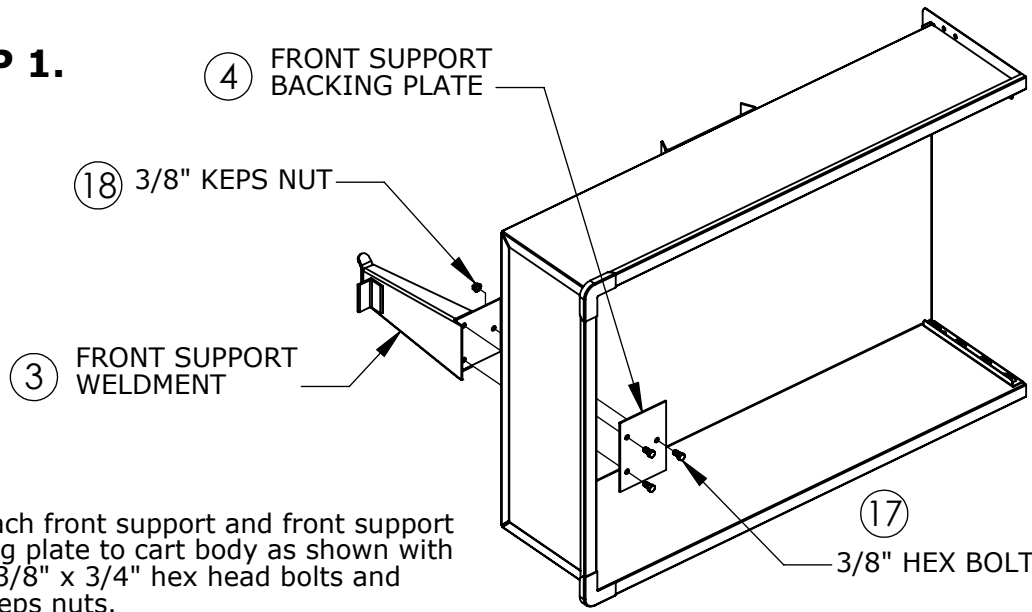

1. Attach front support and front support backing plate to cart body as shown with three 3/8" x 3/4" hex head bolts and 3/8" keps nuts.

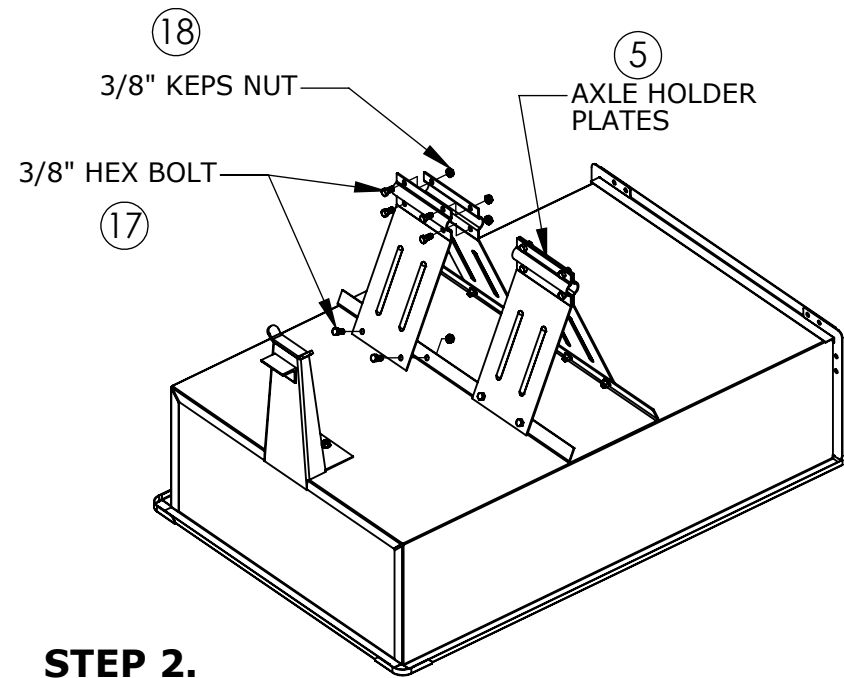

STEP 2.

2. Loosely attach the four axle holder plates with the 3/8"x 3/4" hex head bolts provided. NOTE: these bolts will be tightened after axle and wheels are installed in a later step.

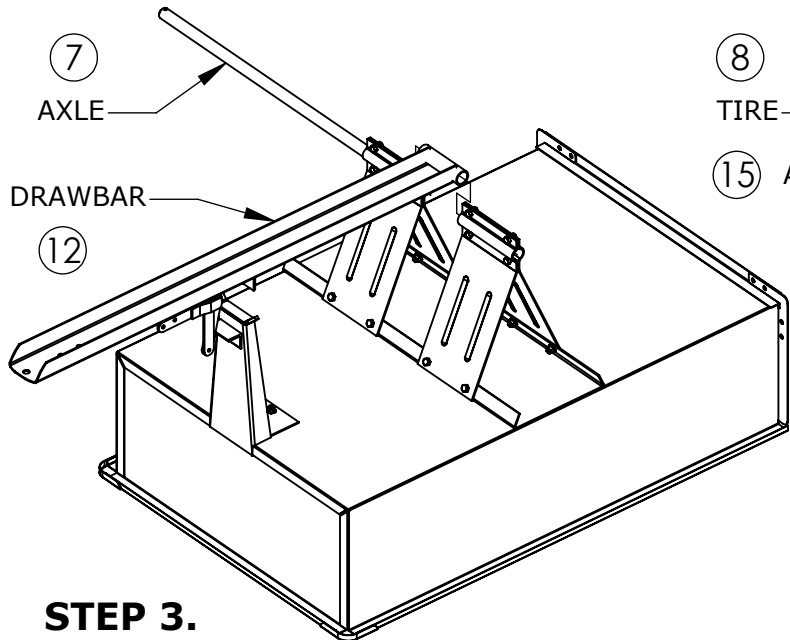

STEP 3.

3. Center drawbar tube between axle holder plates and insert axle, making sure to center axle so that wheels can be put on in the next step.

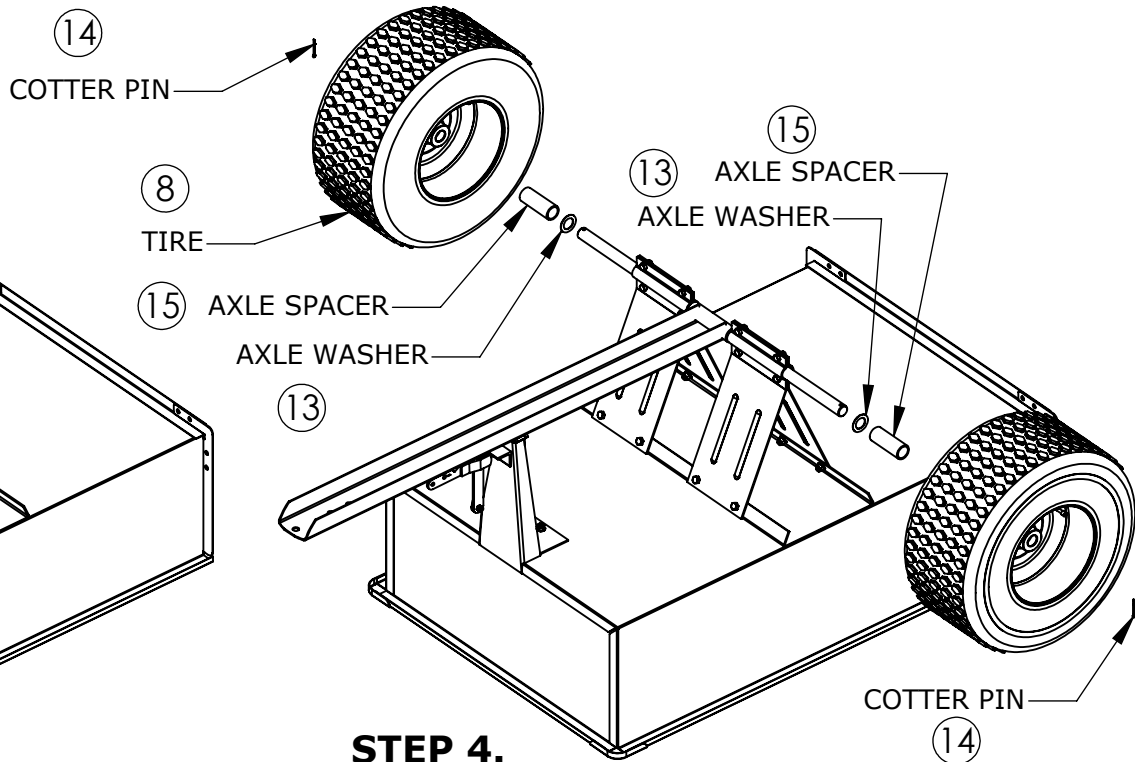

STEP 4.

4. Slide axle washer and axle spacer over each side of axle as shown. Add wheels making sure valve stem faces out. Insert cotter pin in axle and lock in place by spreading ends. Turn cart upright and add tailgate.