

# ME16H702SES

1.6 cu. ft. Over-the-Range Microwave

## Features

- 1.6 cu. ft. Oven Capacity
- 1000 Watts Cooking Power
- 300 CFM Ventilation System
- Charcoal/Grease Vent Filter
- 10 Power Levels
- Two-Stage Programmable Cooking
- Auto Defrost/Auto Reheat
- Auto Cook
- MW Distribution Mechanism: Turntable

## Convenience

- Kitchen Timer
- Interior Light: Incandescent (1)
- Cooktop Lighting: High/Low/Off
- Vent Fan Control: On/Off
- Eco Mode (Reduces Standby Power)



LED Display



300 CFM Ventilation System

## Available Colors



Stainless Steel  
(shown)



White



Black

## Signature Features

### LED DISPLAY

- Features a digital, blue LED Display, complementing any kitchen decor.

### PREMIUM DESIGN

- One-piece door design, with an aluminum handle and side control, provides a seamless and modern look.

### 300 CFM VENTILATION SYSTEM

- Powerful 300 CFM ventilation fan quickly and quietly eliminates food odors.



Ranked **"Highest in Customer Satisfaction with Over the Range Microwaves."**\*

—J.D. Power

**SAMSUNG**

# ME16H702SES

1.6 cu. ft. Over-the-Range Microwave

## Dimensions

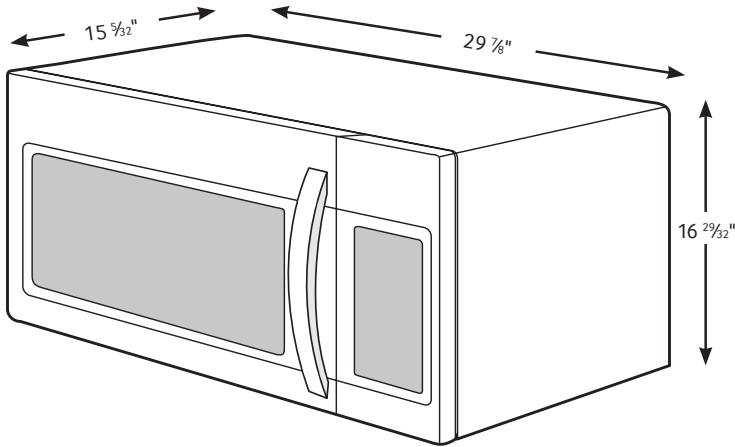

## Installing your Microwave

• This microwave oven is designed for adaptation to the following three types of ventilation:

- A. Outside Top Exhaust (Vertical Duct)
- B. Recirculating (Non-Vented Ductless)
- C. Outside Back Exhaust (Horizontal Duct)

- The space between the cabinets must be 30" wide and free of obstructions.
- This microwave oven is for installation over ranges up to 36" wide.
- The microwave must be level. Use a level to make sure the cabinet bottom is level. If the cabinets have a front overhang only, with no back or side frame, install the mounting plate down the same distance as the front overhang depth. This will keep the microwave level.

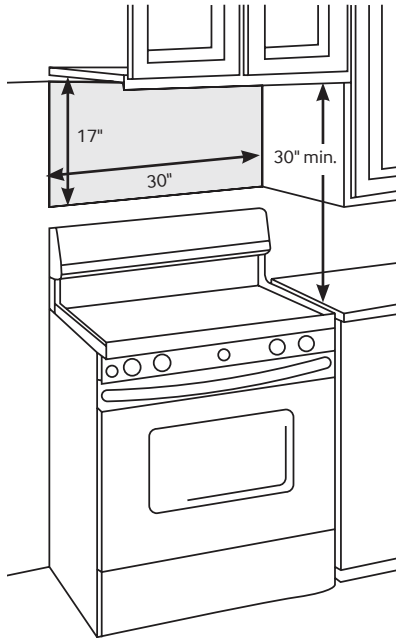

## Specifications

- Oven Cavity: 1.6 cu. ft.
- Power Output: 1000 W
- Power Consumption: 1580 W/13.5 A
- Power Source: 120 V/60 Hz
- Control Method: Digital (Membrane Touch)
- Display: LED
- Cooking Control: 10 Power Levels Including Defrost
- Cooking Timer: Digital, up to 99 Minutes, 99 Seconds
- Microwave Distribution System: Turntable
- Glass Turntable Diameter: 11 1/2"
- Vent Fan: 300 CFM
- Vent Fan Control: On/Off
- Cooktop Lighting: High/Low/Off

## Warranty

One (1) Year All Parts and Labor  
Ten (10) Years Parts on Magnetron

## Product Dimensions & Weight (WxHxD)

Cavity Dimensions:  
19 5/16" x 9 5/8" x 14 3/8"

Outside Net Dimensions:  
29 7/8" x 16 29/32" x 15 5/32"

Weight: 46.8 lbs. (Stainless)  
45.5 lbs. (White, Black)

## Shipping Dimensions & Weight (WxHxD)

Dimensions:  
33 3/8" x 19 13/32" x 20 5/32"

Weight: 53.7 lbs. (Stainless)  
52.2 lbs. (White, Black)

Color	Model #	UPC Code
Stainless Steel	ME16H702SES	887276690162
White	ME16H702SEW	887276690834
Black	ME16H702SEB	887276690827

FOR EASIER INSTALLATION AND PERSONAL SAFETY, WE RECOMMEND THAT TWO PEOPLE INSTALL THIS MICROWAVE OVEN. IMPORTANT: Do not grip or use handle during installation.

NOTE: If your cabinet is metal, use the nylon grommet around the power cord hole to prevent cutting of the cord.

NOTE: We recommend using filler blocks if the cabinet front hangs below the cabinet bottom shelf.

IMPORTANT: If filler blocks are not used, case damage may occur from over tightening screws.

NOTE: When mounting the microwave oven, thread power cord through hole in bottom of top cabinet. Do not pinch cord or lift oven by pulling cord.

\*Samsung received the highest numerical score for over the range microwaves in the proprietary J.D. Power 2014 Kitchen Appliance Study<sup>SM</sup>. Study based on 15,380 total responses measuring 15 over the range microwave brands and measures opinions of consumers about their new appliance purchased in the past 24 months. Proprietary study results are based on experiences and perceptions of consumers surveyed in January-March 2014. Your experiences may vary. Visit [jdpower.com](http://jdpower.com).

Actual color may vary. Design, specifications, and color availability are subject to change without notice. Non-metric weights and measurements are approximate.

©2014 Samsung Electronics America, Inc. 85 Challenger Road, Ridgefield Park, NJ 07660. Tel: 800-SAMSUNG. [samsung.com](http://samsung.com). Samsung is a registered trademark of Samsung Electronics Co. Ltd.

**SAMSUNG**