

# Classic Vinyl Picket Gate



**TRADITIONAL**

**REALLY**



**Important stuff to know about  
installing your WamBam gate.**

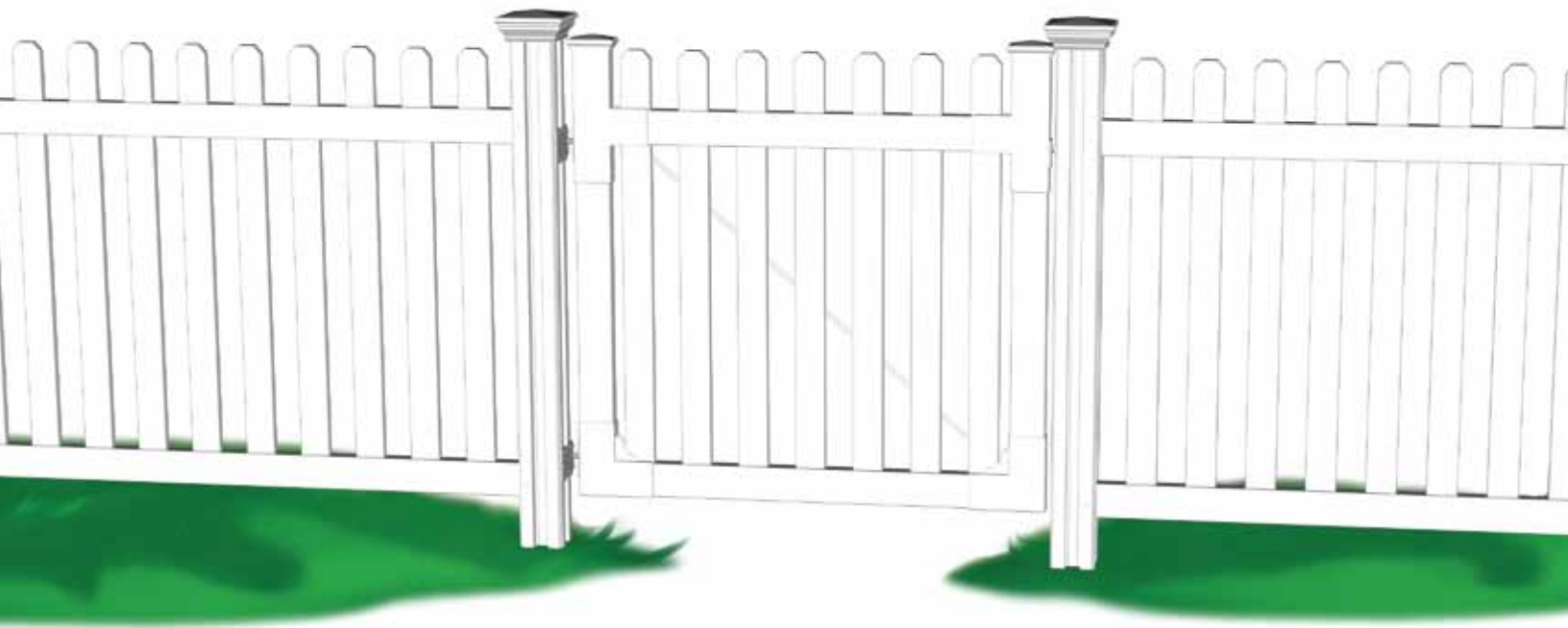

**1-877-778-5733**

[www.wambamfence.com](http://www.wambamfence.com)

# Classic Picket Vinyl Gate Reality Check

# WamBam FENCE

## TRADITIONAL

### 1 - Read Over Fence Instructions First

Your gate and fence will work better together as an integrated solution if you first take the time to read and understand your fence instructions.

### 2 - Do a Dry Run First on the Gate Frame Only (not pickets or boards)

Please do not glue or screw your gate frame together until you have first temporarily assembled the gate. In other words, do a dry run first.

This will ensure three things:

- a) *That you have everything necessary to complete the gate.*
- b) *That you will have assembled the gate in the correct order.*
- c) *All the pieces fit and function properly.*

It's easier to trouble shoot when things are not glued and screwed together. After you assemble your gate correctly, please disassemble as necessary and use glue and screws to permanently assemble the gate.

### 3 - Ideally, Install Your Gate Posts Before Your Fence Posts

Your fence panels will be more forgiving for a custom fit than your gate. Ideally, position and install your gate posts before you do anything else, or very early on in the process of setting up your fence run.

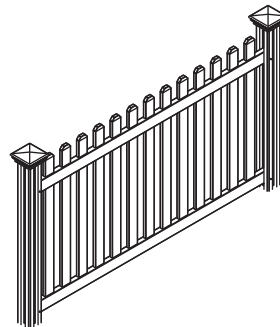
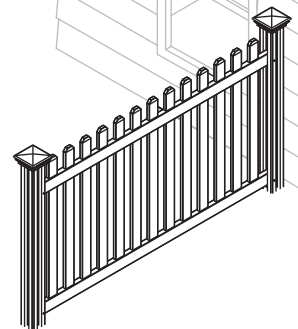
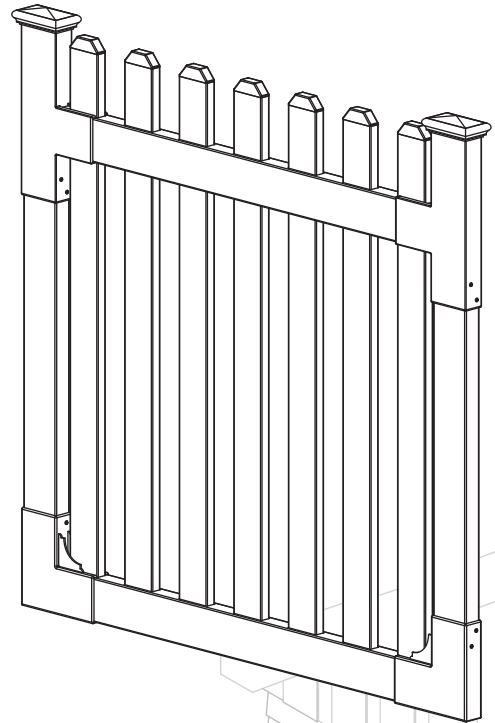

**Install Your Gate Posts  
Before Installing Your  
Fence Posts.**

For more information,  
contact us at 1 877-778-5733.

## 4 - Ideally, Do Not Hang Your Gate System Off a Single Non-Supported Post.

Your gate will perform better and last longer if your hinge post is connected to a panel of fence which is connected to another post. The weight strain will be transferred unto two posts versus just one. Installing fence panels on both sides of your gate is the ideal in all situations. If this is not possible because of space restrictions, please contact us for alternative solutions to overcome.

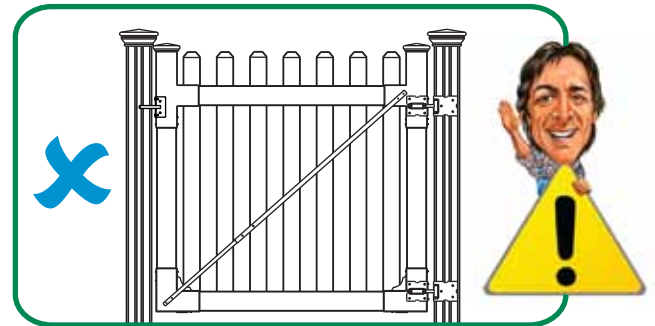
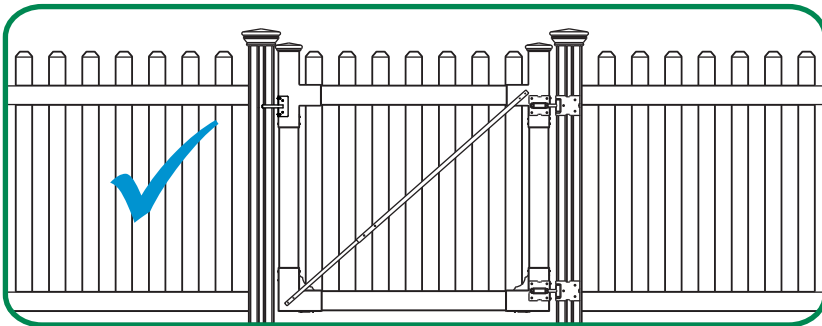

*Do Not Hang Gate on Lone Soldier Post.*

## PRODUCT OVERVIEW

### Gate Assembly

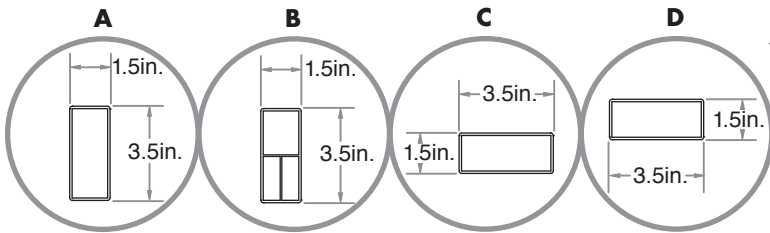
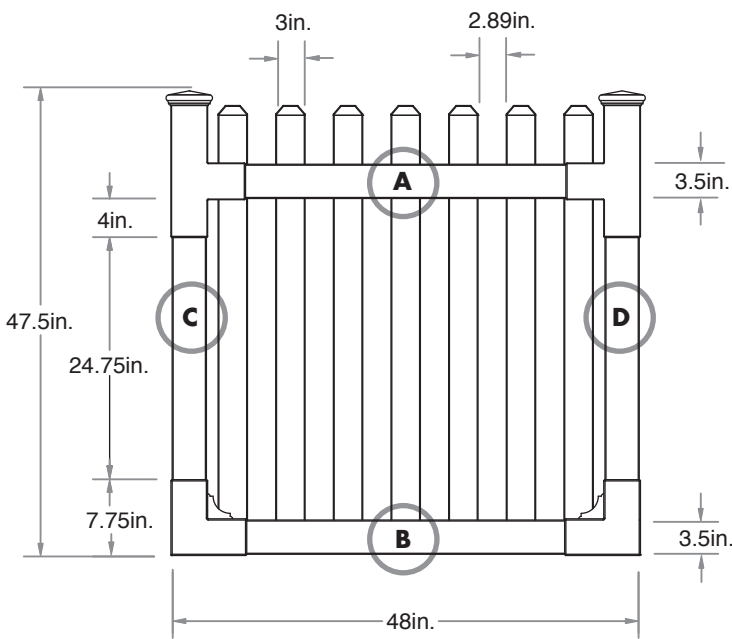

.090in. wall thickness

### Gate Installation

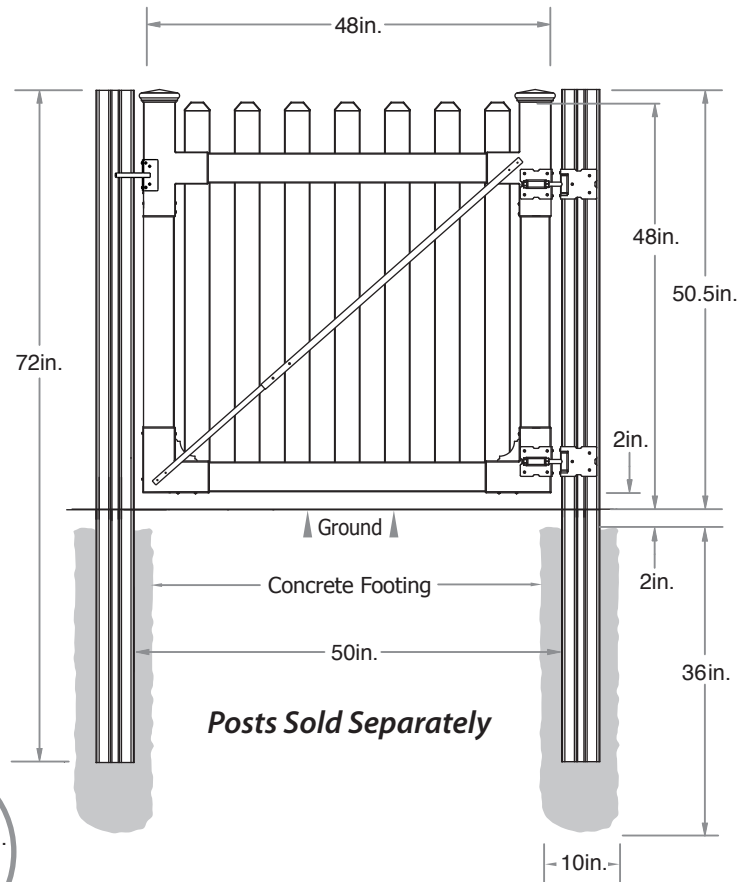

*Posts Sold Separately*

# Classic Picket Vinyl Gate

## Box Contents



### TRADITIONAL

#### Each Gate Box Includes:

- Gate Caps (2)
- T-Brackets (2)
- Gate Hinges (2)
- Picket Caps (7)
- Top Rail (1)
- Gate Latch (1)
- Vertical Stiles (2)
- Pickets (7)
- Stainless Steel Screws (20)
- Gate Brace (1)
- Bottom Rail (1)
- Tubes of Glue (2)
- Gate Bottom Brackets (2)

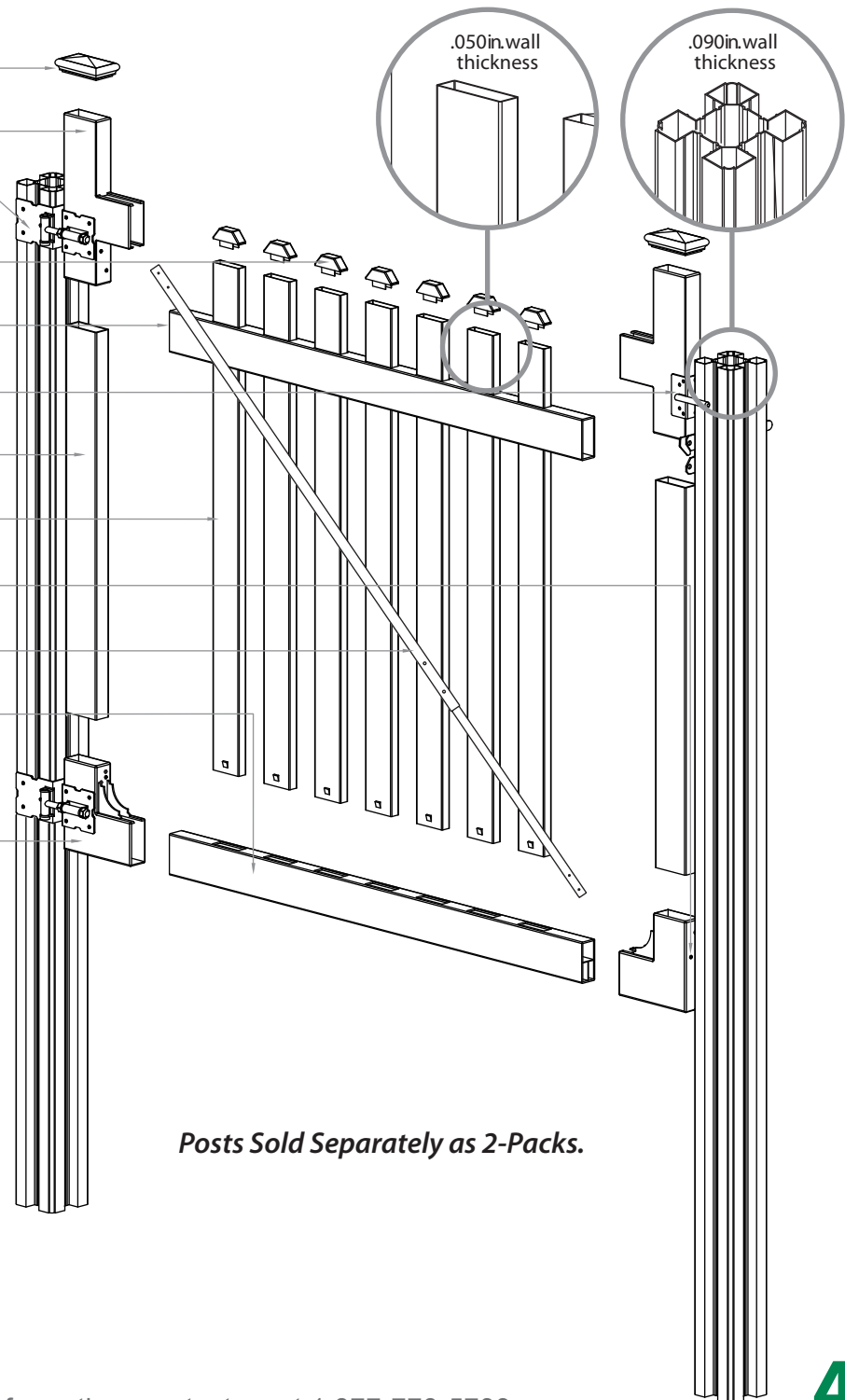

#### Sold Separately:

- 6ft. Posts (2-Pack)

*Posts Sold Separately as 2-Packs.*

# Classic Picket Vinyl Gate Customize Your Gate Design



## TRADITIONAL

Use The Cutting Guide Below To Trim Pickets  
to Create A Custom Gate Design

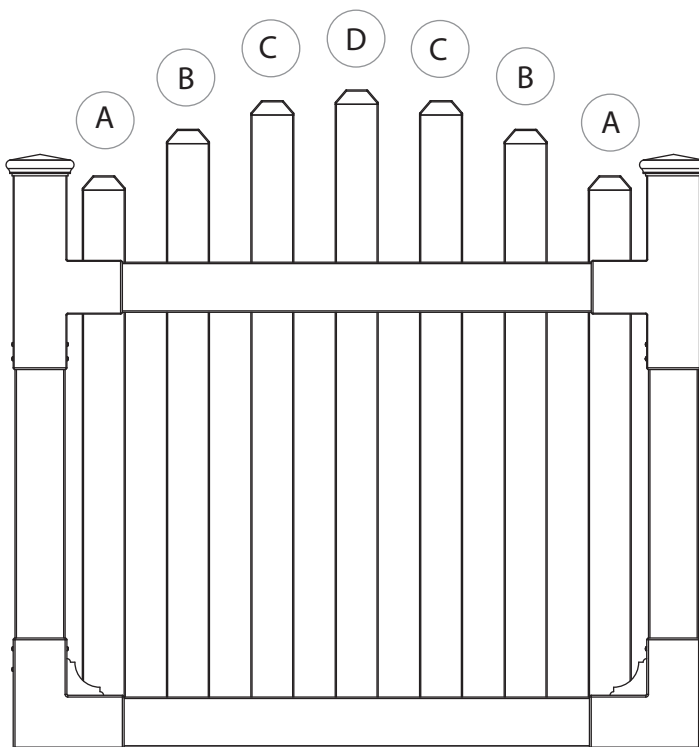

*This Gate Can Also Be Trimmed  
Down Both in Width and Height to  
Accomodate Custom Applications.*

A	37 1/8in.
B	40 3/8in.
C	42 3/8in.
D	43 1/8in.

*Please Note:  
Cut down the vertical stiles by 6in.*

## Detailed Installation Instructions

TRADITIONAL

### STEP 1 Assemble the Gate Frame Bottom & Sides

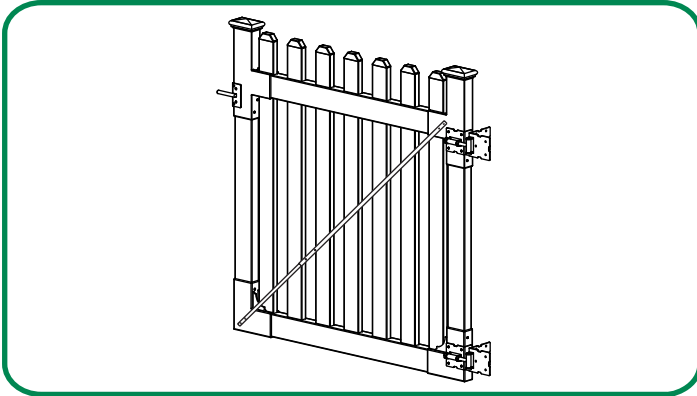

Completely assembled gate shown



**A -** Run bead of vinyl weld continuously around the inside of the gate bracket

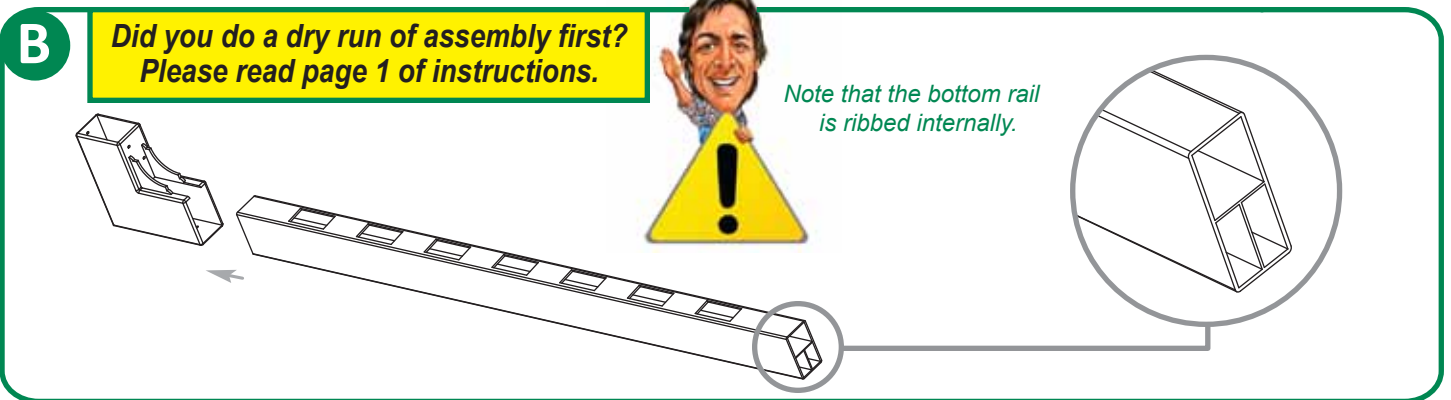

**B -** Insert the bottom rail until it bottoms out inside gate bracket

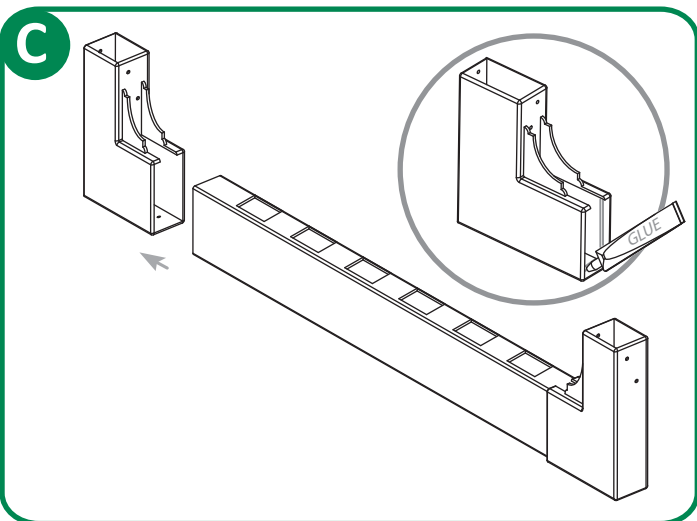

**C -** Insert the bottom rail until it bottoms out inside gate bracket

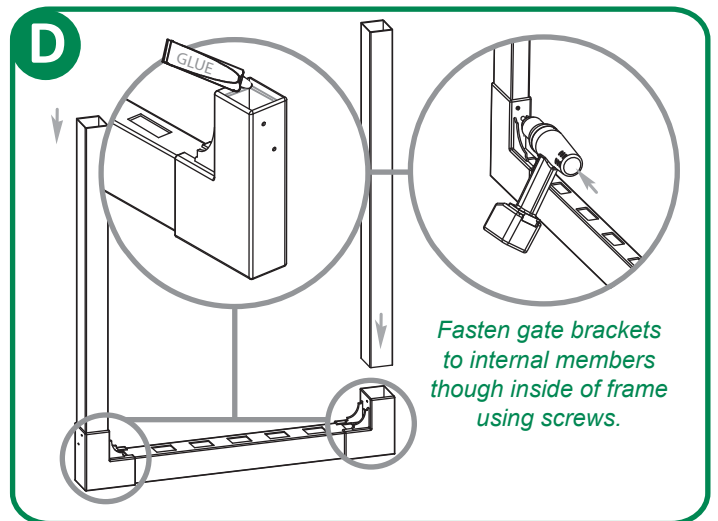

**D -** Insert vertical gate stiles. They will bottom-out against bottom horizontal rail

**STEP 2 Assemble the Gate Frame  
Top & Attach to Sides**

**A**

*Did you do a dry run  
of assembly first?  
Please read page 1  
of instructions.*

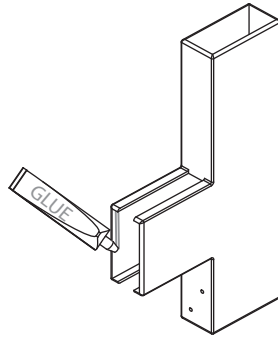

**A - Run bead of vinyl-weld continuously around the inside of the bracket**

**B**

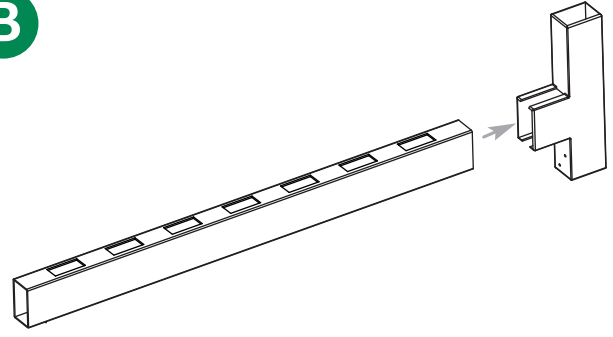

**B - Insert top rail until it bottoms out inside the bracket**

**C**

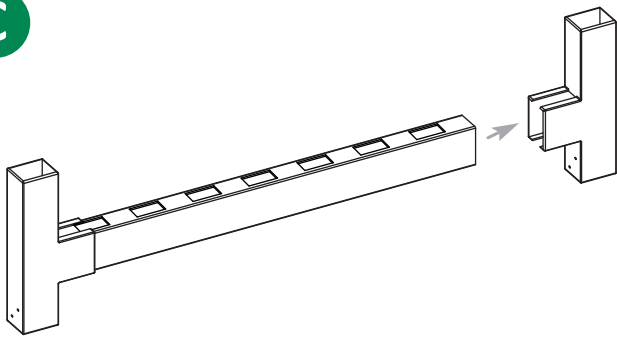

**C - Insert rail until it bottoms out inside bracket (glue first)**

**D**

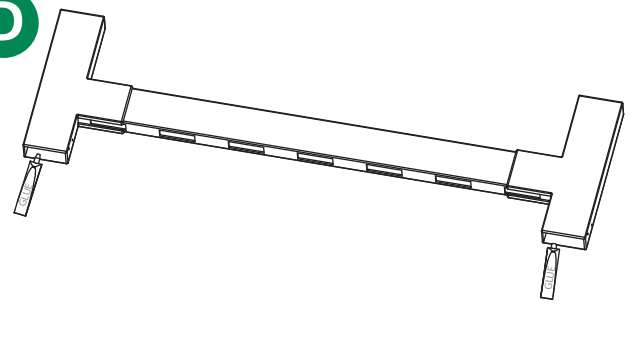

**D - Run a bead of vinyl-weld continuously around the inside of the brackets**

**E**

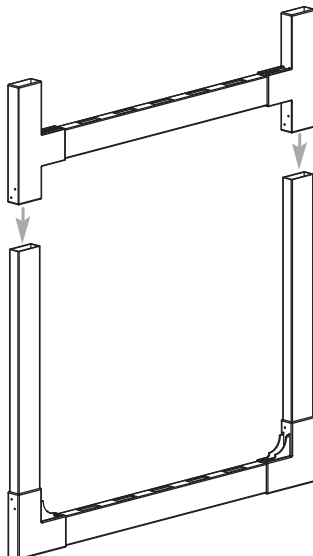

**E - Slide brackets with toprail attached down over the vertical gate stiles**

**F**

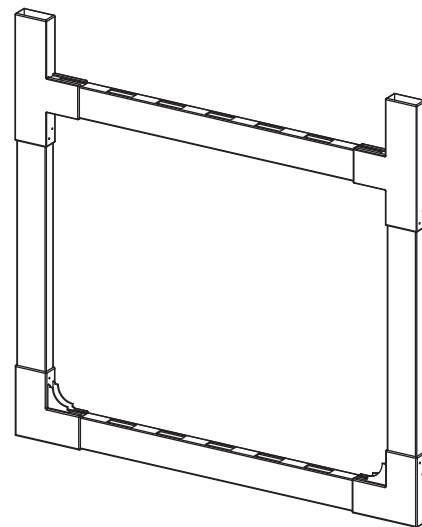

**E - Completely assembled gate frame shown**



**STEP 3** Screw Gate Frame/Brackets

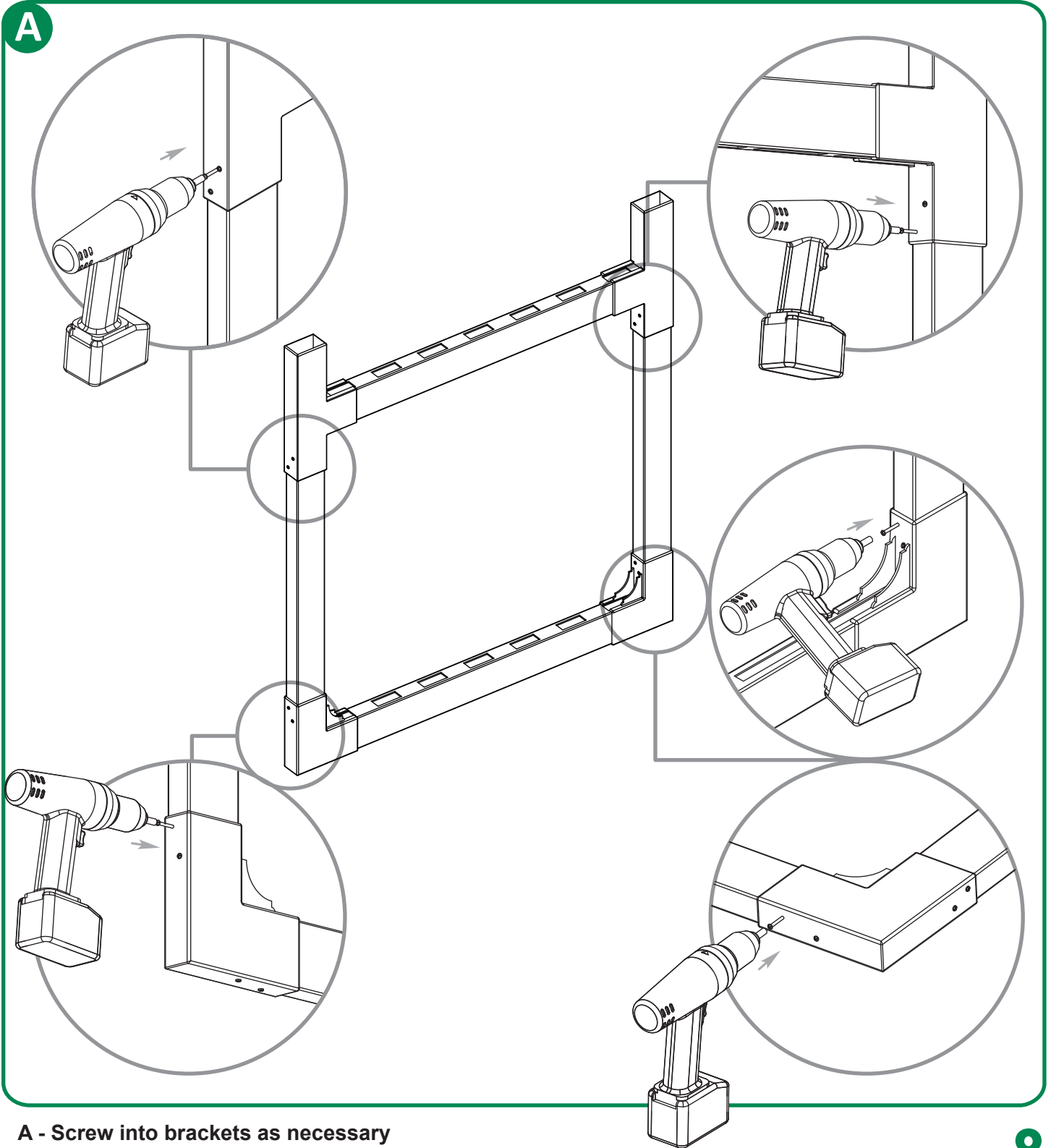

**A - Screw into brackets as necessary**

For more information, contact us at 1 877-778-5733.

**STEP 4**

**Insert Pickets Into Gate Frame & Attach Caps**

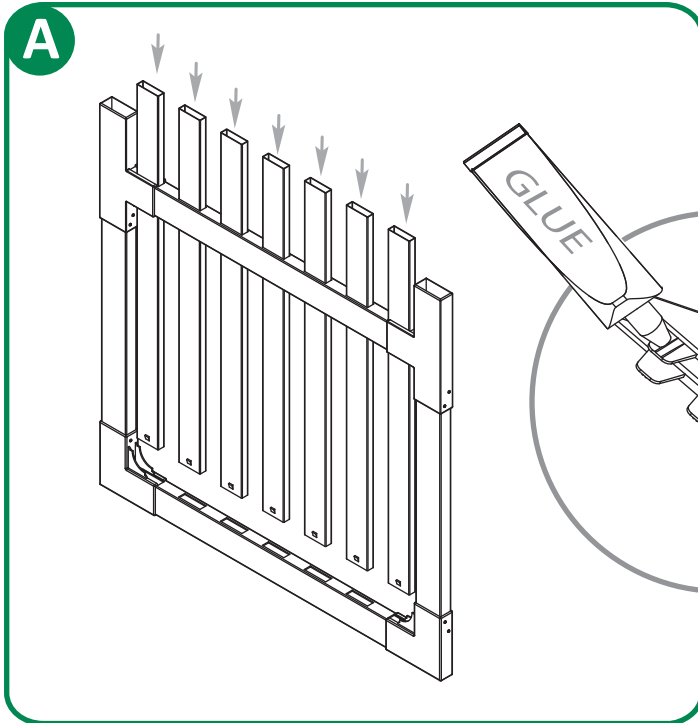

**A - Insert pickets with tab ends through top rail**

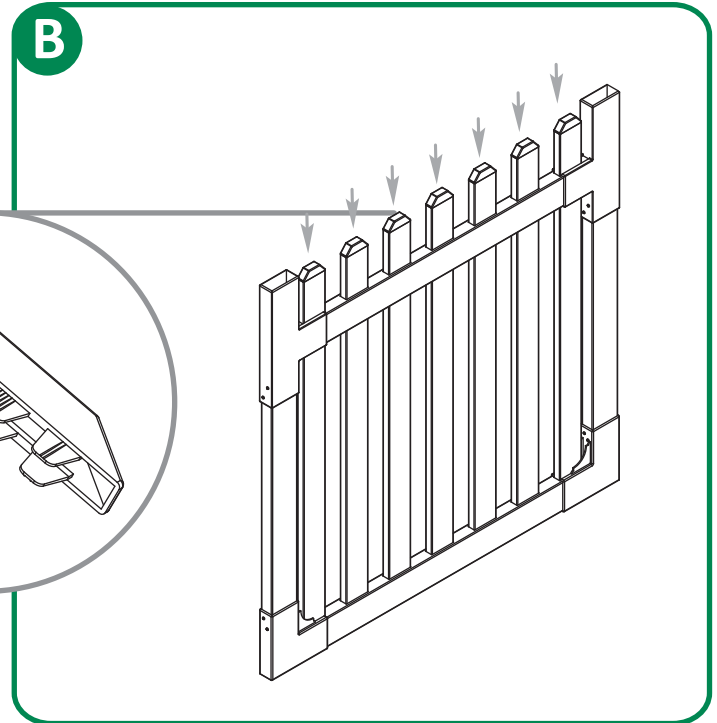

**B - Glue picket caps and attach to top of pickets**

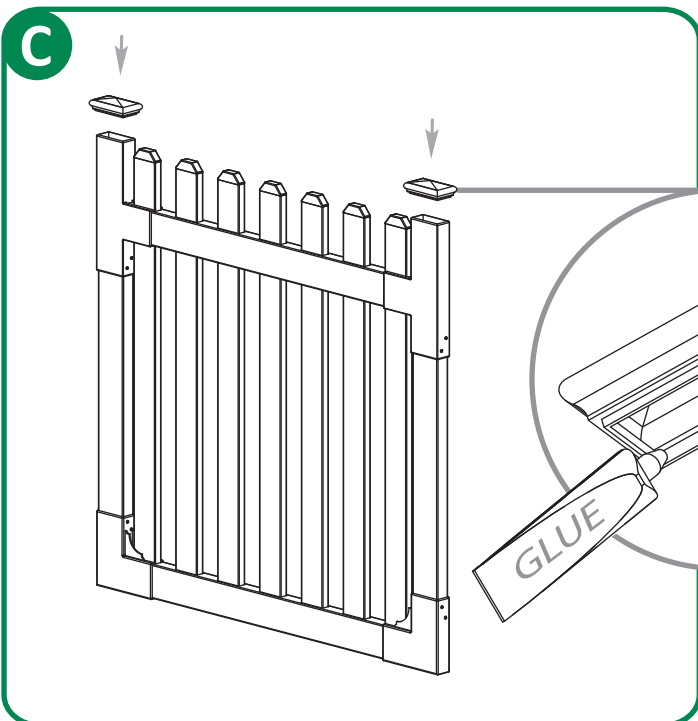

**C - Glue bracket caps and attach to top of brackets**

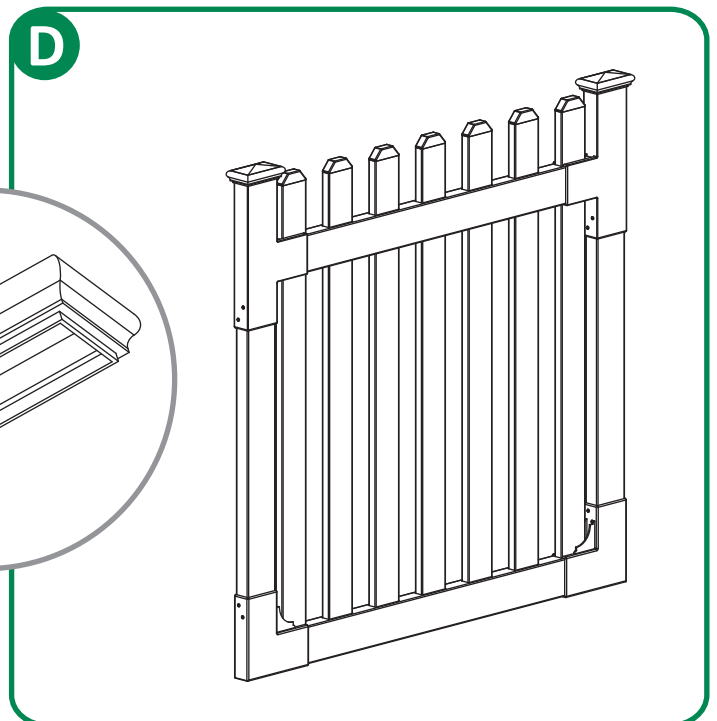

**D - Completed gate with frame shown**

**STEP 5**

**Fasten Gate Hinges  
& Gate Latch**

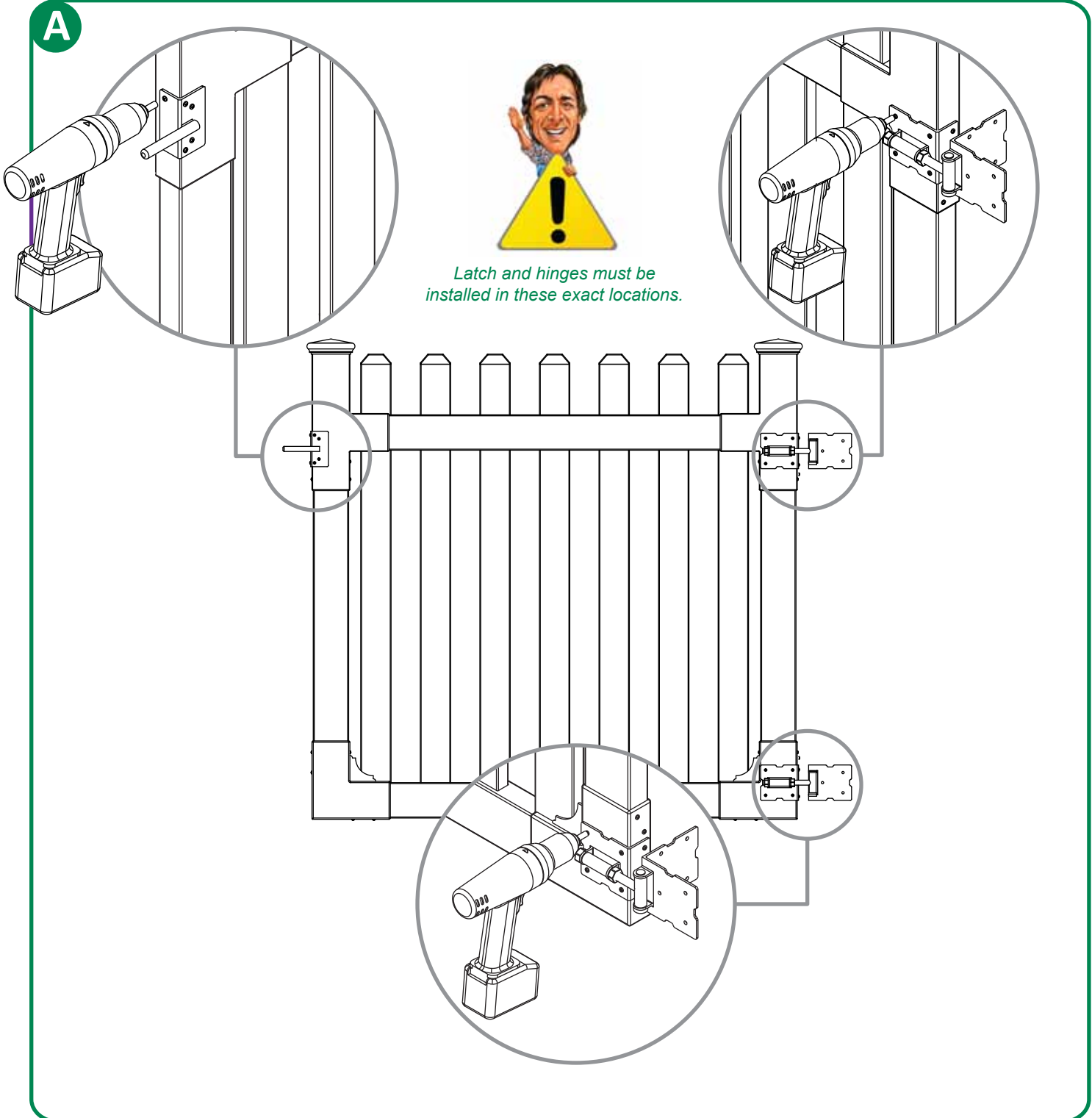

**A - Fasten gate hinges and gate latch onto the gate brackets with SHORT screws**

For more information, contact us at 1 877-778-5733.

**STEP 6**

## Assemble & Fasten Gate Brace

### Gate Brace Parts

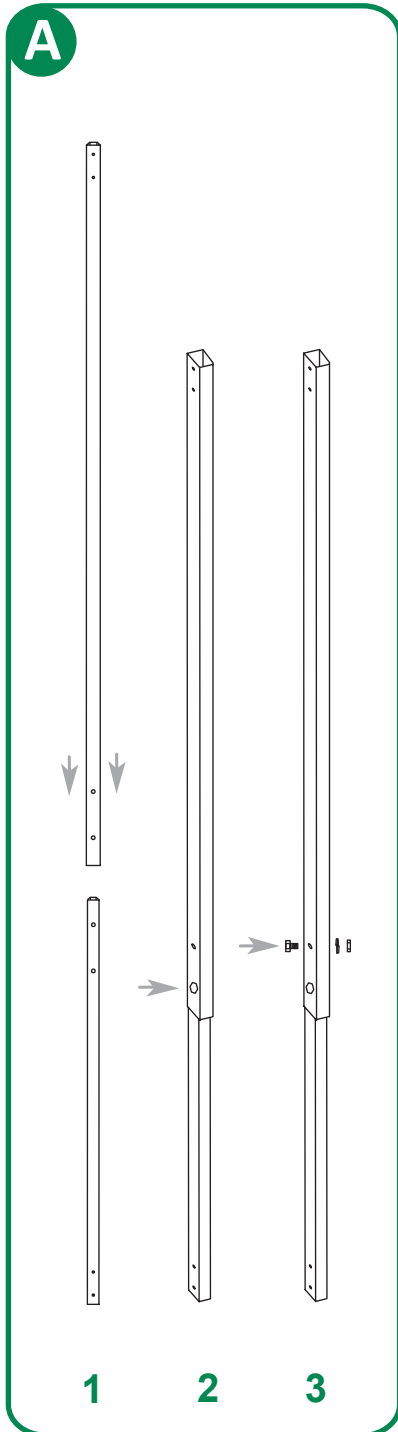
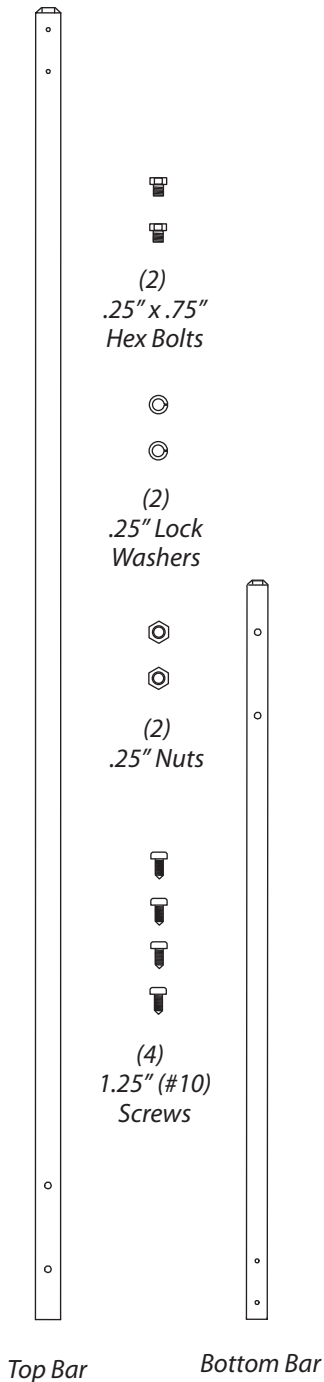

**A - Assemble gate brace with bolts, washers and nuts as necessary.**

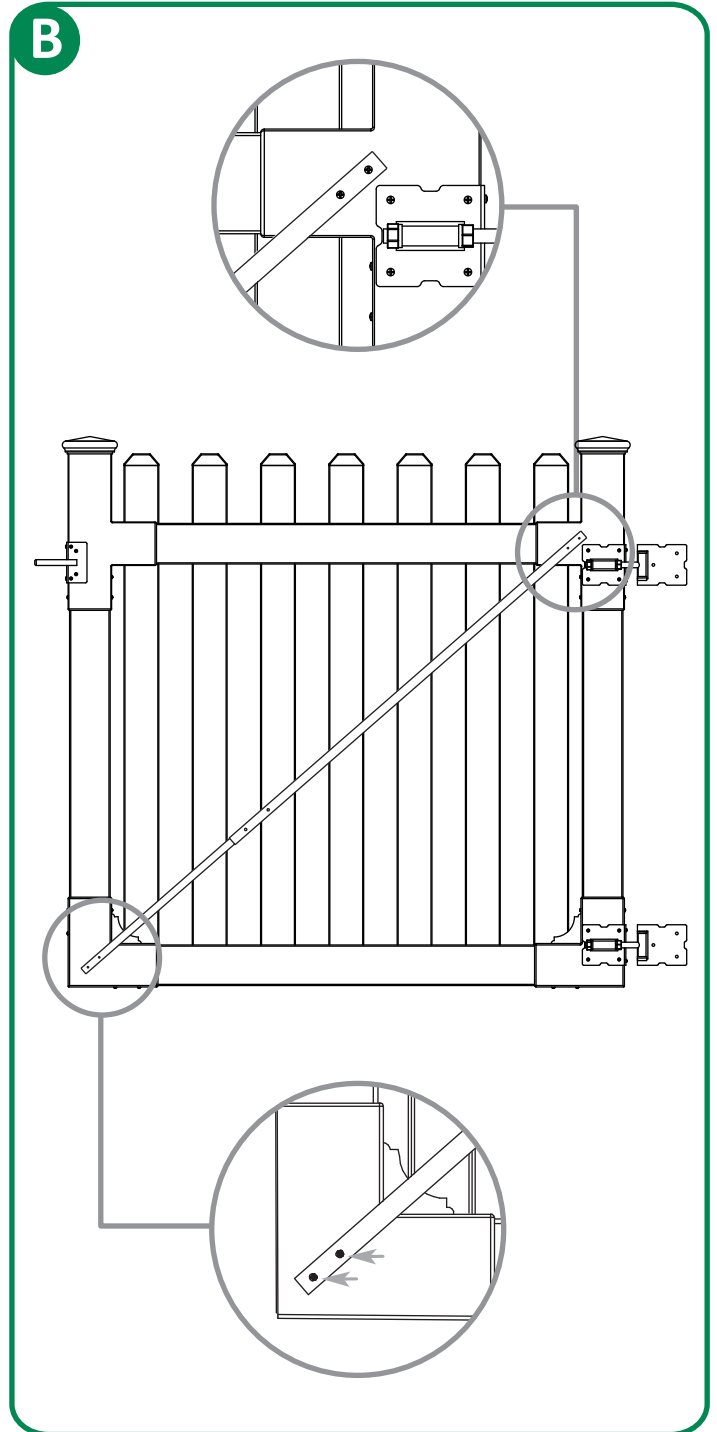

**B - Ensure that gate is square, then screw bracing into place.**

For more information, contact us at 1 877-778-5733.

**STEP 7**

**Position, Adjust & Align Gate/  
Secure Hinges to Posts**

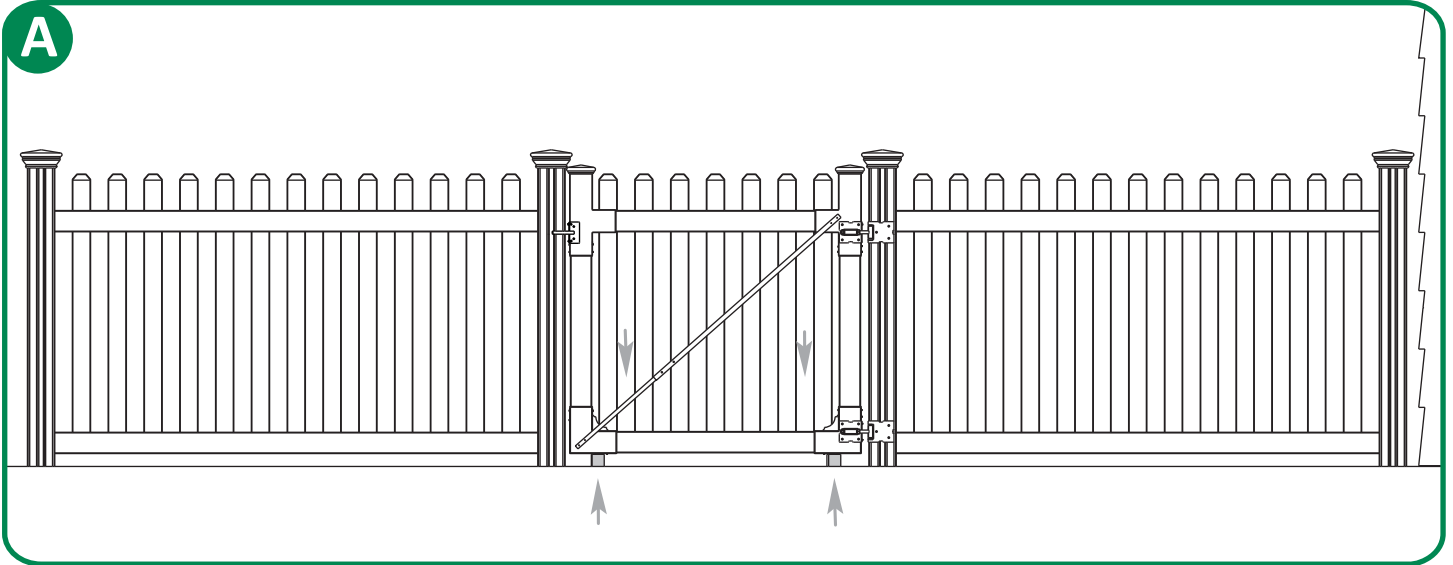

**A - Use temporary spacers or blocks to rest the gate on during alignment and installation**

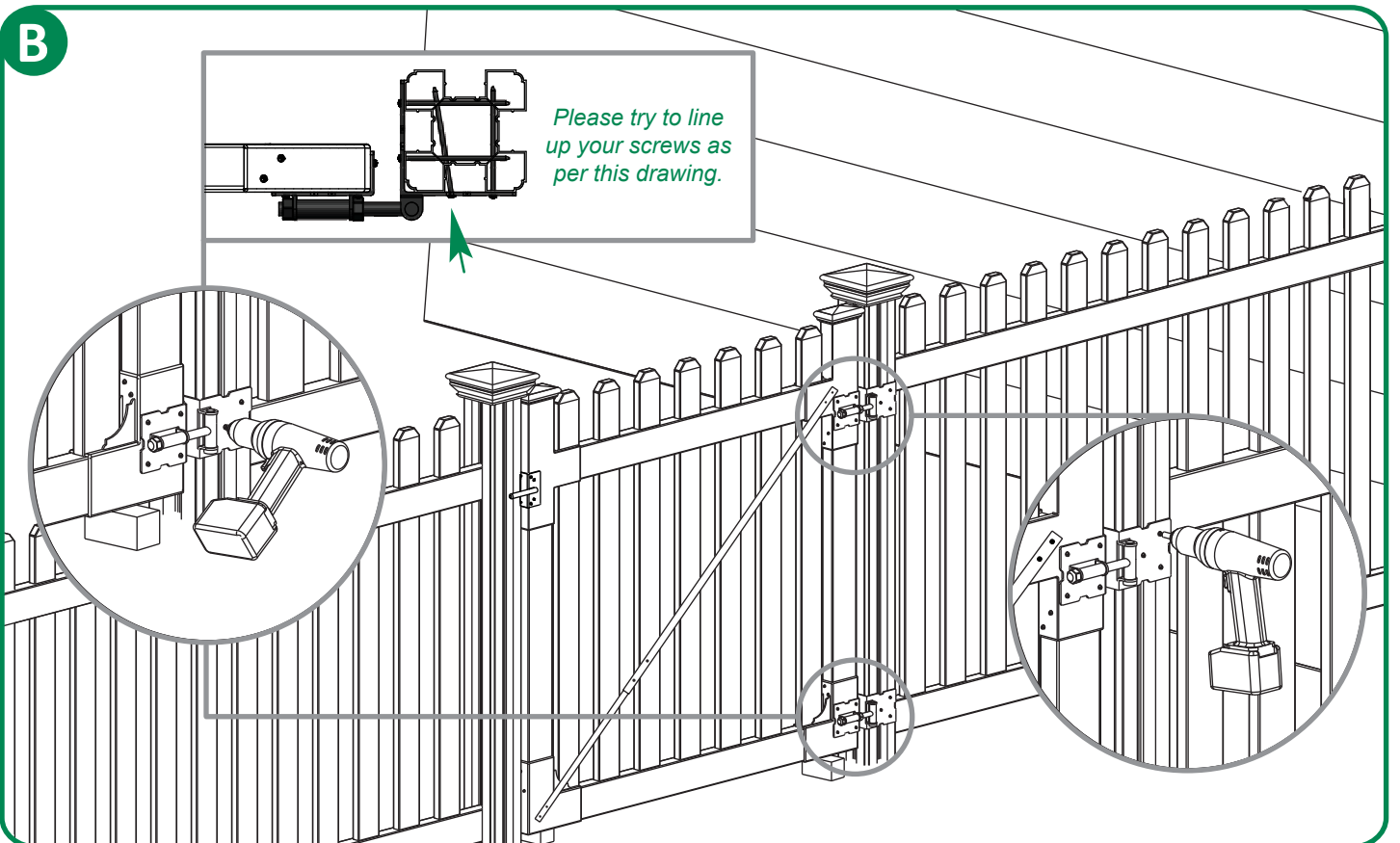

*Please try to line up your screws as per this drawing.*

**B - Fasten hinges to posts with LONG screws**

For more information, contact us at 1 877-778-5733.

STEP 8 Level Gate & Adjust Hinges

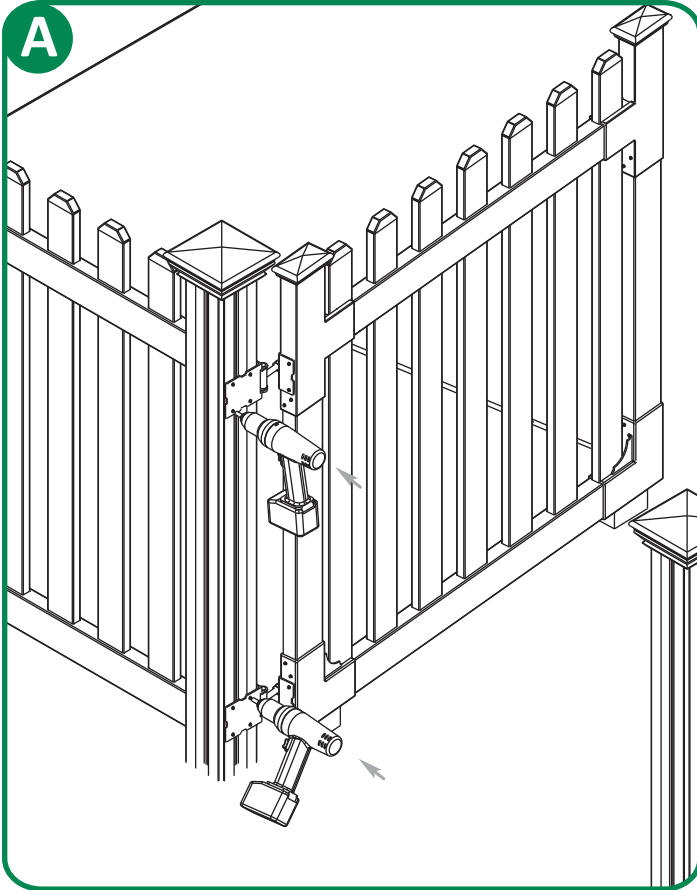

A - Fasten gate hinges accordingly

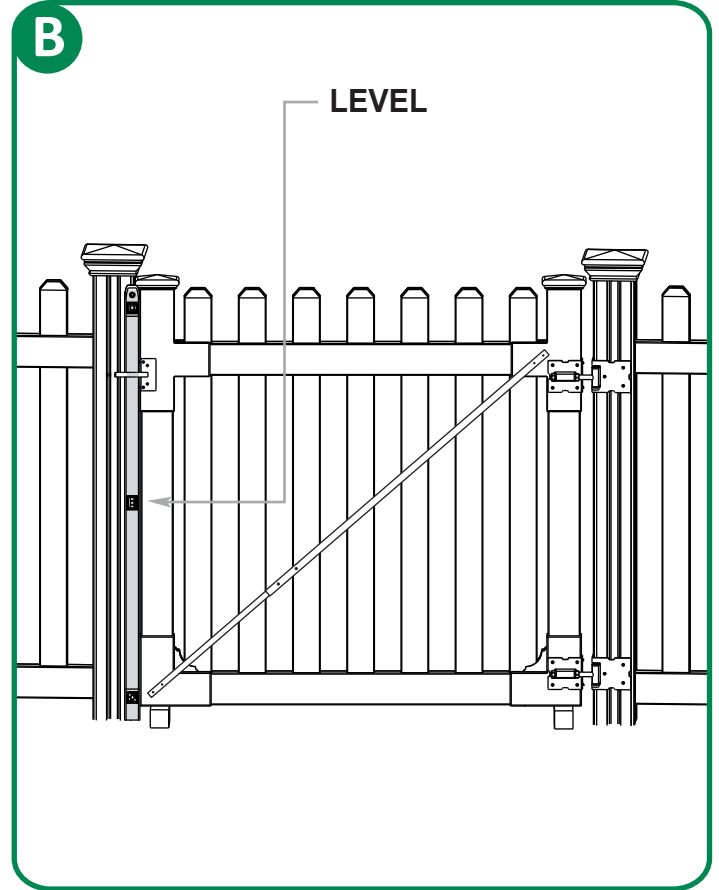

B - Check for level, fit and function to latching post

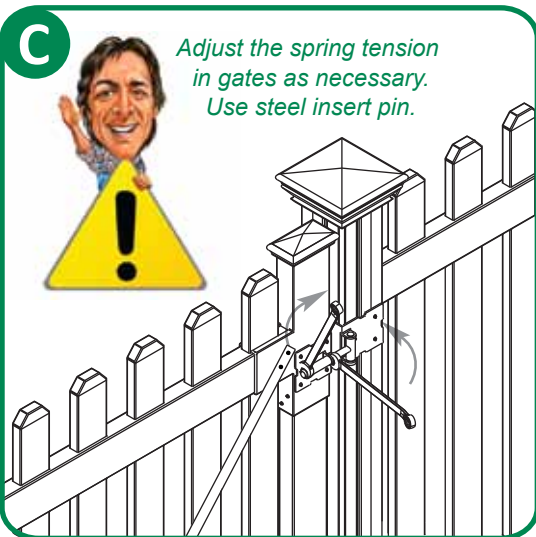

C - Hinges can be adjusted moderately to bring gate into level alignment with post

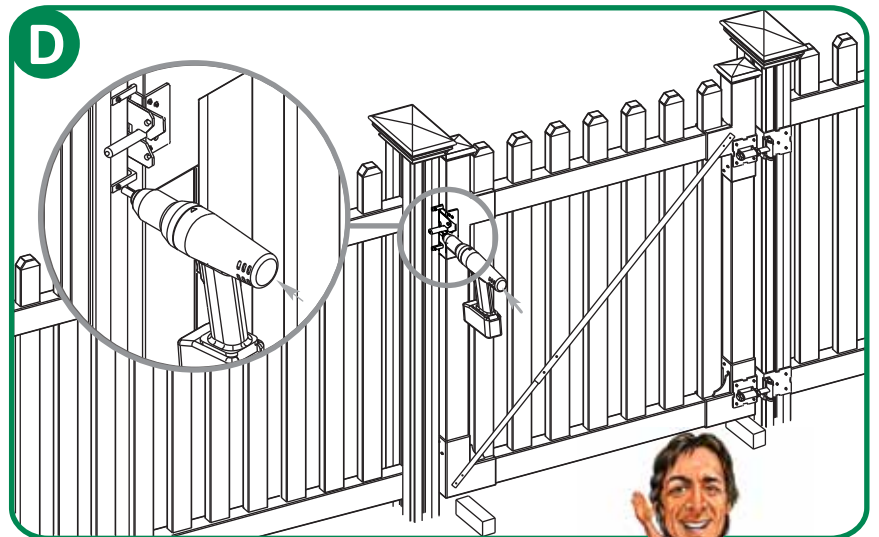

D - Latch is designed for left and right hand applications. Temporarily remove the spring, bolt and reverse paddle portion as necessary.



**STEP 9** Align & Install Latch

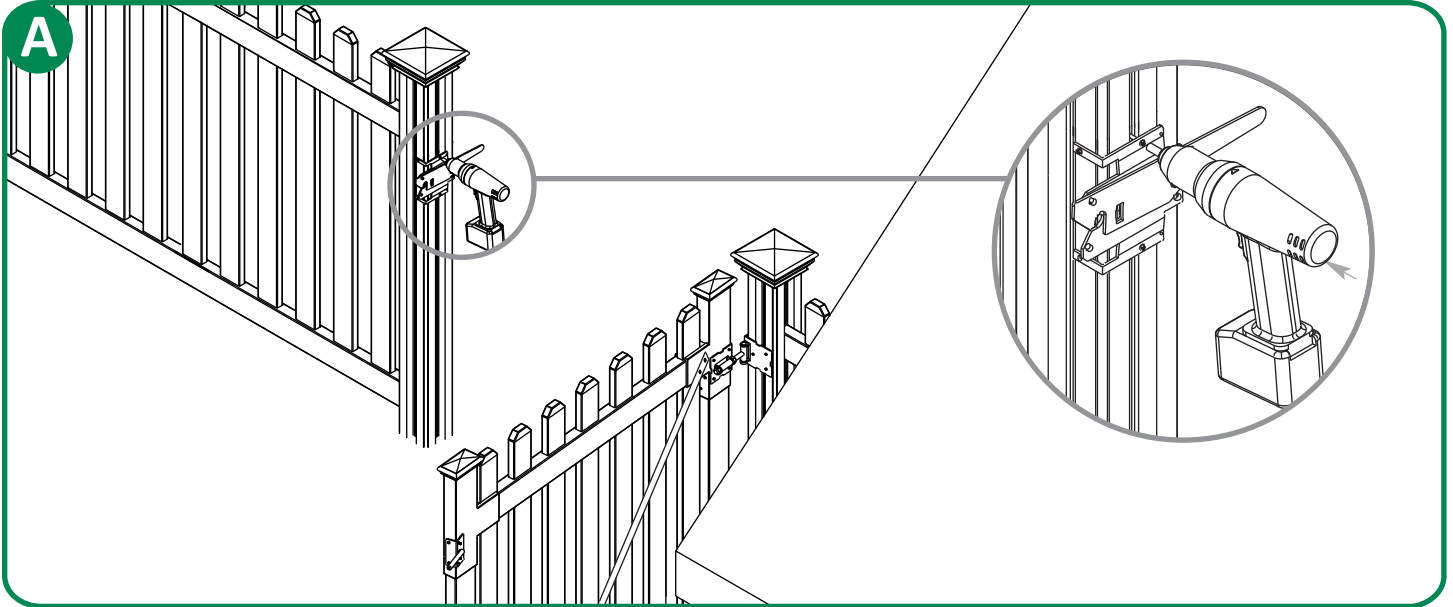

A - Align and fasten the gate latch catch to fit and function with the gate finger.

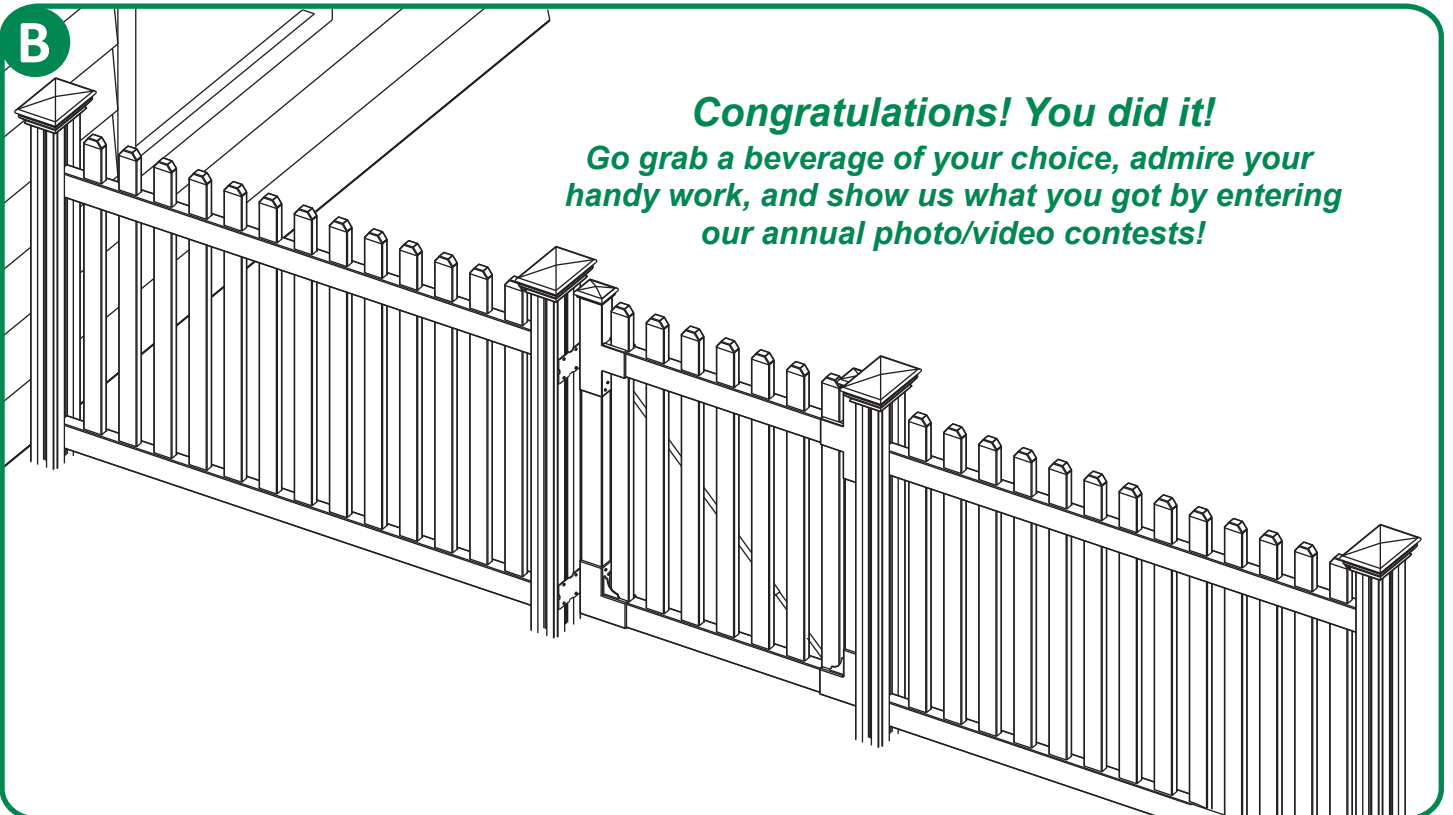

***Congratulations! You did it!***  
*Go grab a beverage of your choice, admire your handy work, and show us what you got by entering our annual photo/video contests!*