

Installers & User guide **Deadbolt 2S.**

Welcome!

This guide will get you up and running with your igloohome Deadbolt 2S. In the meantime, you should follow igloohome on Facebook and Youtube!



Like us on Facebook



Visit our Youtube



As our igloohome app is frequently updated, there may be changes to this manual. Please refer to our website igloohome.co/support for the latest version of the manual.

Table of Contents

What's Included	3
Specifications	4
Installation Guide	
Requirements	5
Prepare Door for Installation	6
Prepare Lock for Installation	7
Installation Instructions	9
Test Lock	13
Prepare the Door Frame	14
User Guide	
Lock Anatomy	15
Features	16
Unlocking and Locking	18
App Onboarding	19
Managing Access in App	20
Lock Tutorial	21
Lock Behaviour	22
Airbnb Connect	23
Troubleshooting	24

What's Included



**Front Assembly
& Rubber Gasket**

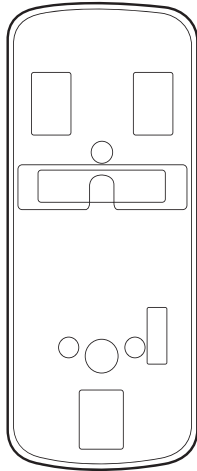

**Back Assembly
Rubber Gasket**



Back Assembly

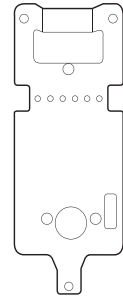

Back Plate

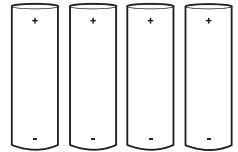

AA Alkaline Batteries x4

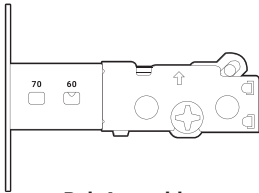

Bolt Assembly

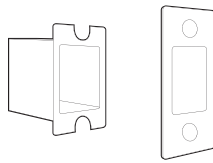

**Strike Plate Housing &
Strike Plate**



Screw Holder

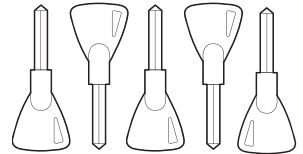

Keys x5

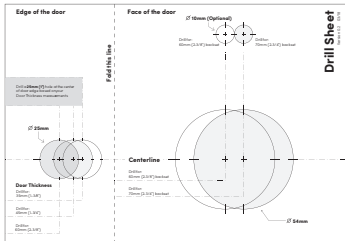

Drill Sheet



**5mm (13/64")
Bolt Screw x2**



**8mm (5/16")
Bolt Screw x2**

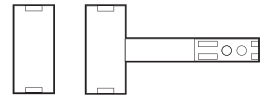

Door Sensor & Magnet

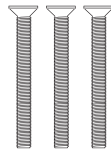

**43mm (1-11/16")
Bolt Screw x3**

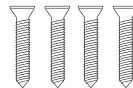

**15mm (19/32")
Wood Screw x4**



**20mm (25/32")
Bolt Screw**

Specifications

Model	igloohome Smart Deadbolt 2S
Material	Zinc Alloy, ABS
Current Rating (Standby)	~30uA
Current Rating (Active)	~200mA
Batteries	4 x AA Alkaline
Battery Life	Up to 9 months
Unlock Mechanism	Bluetooth, PIN code, Physical Keys, Thumbturn

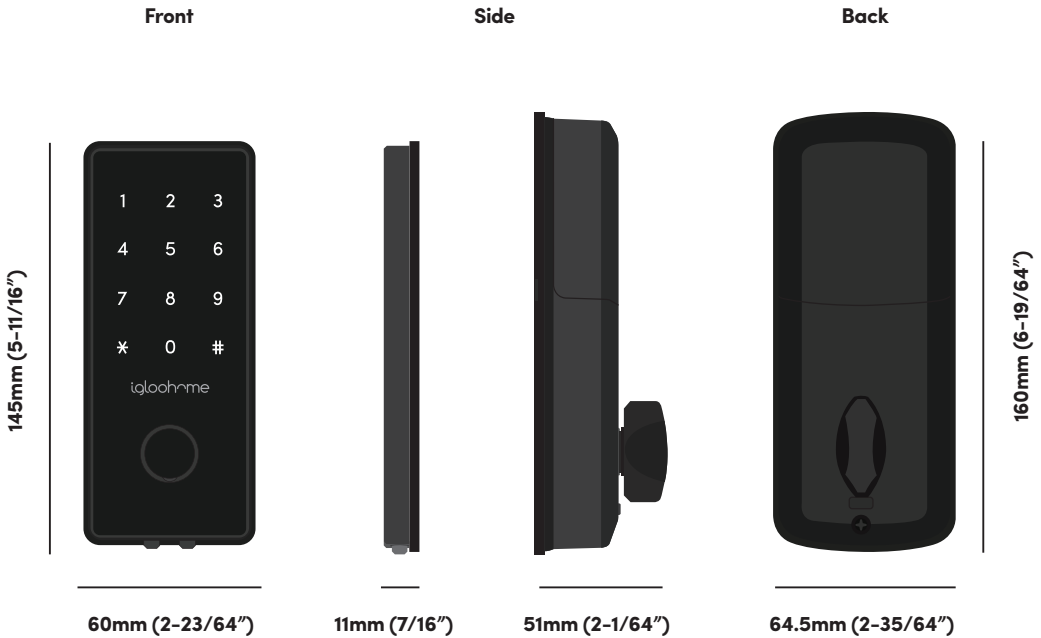

* **DO NOT USE:** Heavy Duty, Eveready, GP, or rechargeable batteries. Duracell & Energizer alkaline batteries recommended. Please note that using better batteries will improve the performance and lifespan of the lock.

Installation Guide

Requirements

Door Thickness

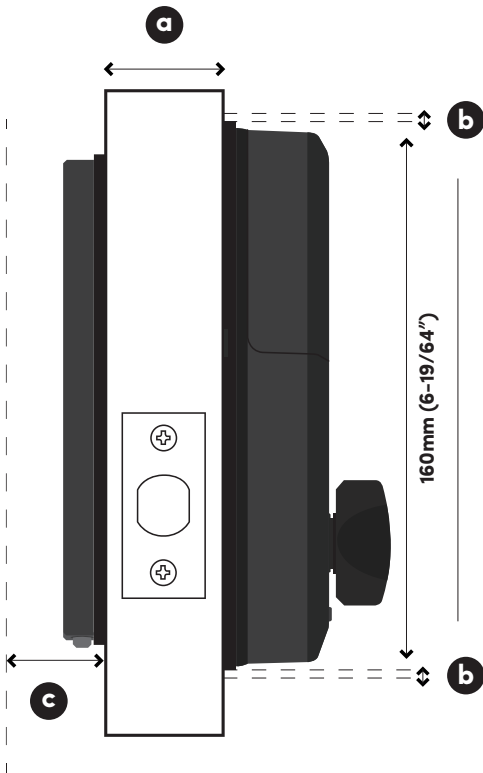

Clearance

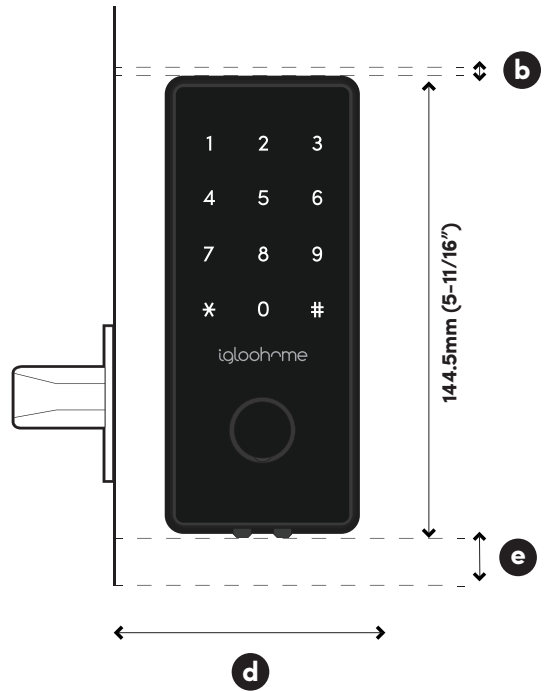

Measurements

- a** 35mm (1-3/8") to 60mm (2-3/8")
- b** 10mm (25/64")
- c** 20mm (25/32")
- d** >110mm (4-21/64") for 60mm (2-3/8") / >120mm (4-23/32") for 70mm (2-3/4") backset
- e** 50mm (2")

Prepare Door for Installation

Items needed:

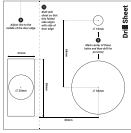

Drill Sheet



Drill



10mm (25/64")
Drill Bit



54mm (2-1/8")
Hole Saw

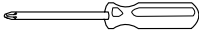

#2 Phillips Screw Driver



25mm (1")
Spade Bit

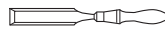

20mm (25/32")
Chisel

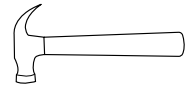

Hammer

Recommended

Door and door frame material : **Wood**



Recommended

Gap between door and door frame: **<3mm (1/8")**

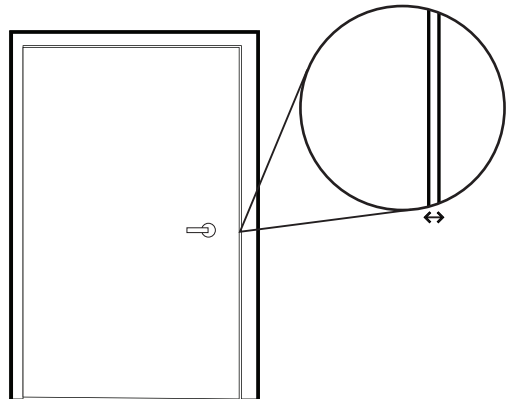

Please ensure that there is an existing handle on your door for push - pull access.

Not for: metal gates, glass doors or sliding doors.

If you are unsure if your door is suitable, send us web links to your door pictures to info@igloohome.co

How to use the Drill Sheet

Drilling (Door)

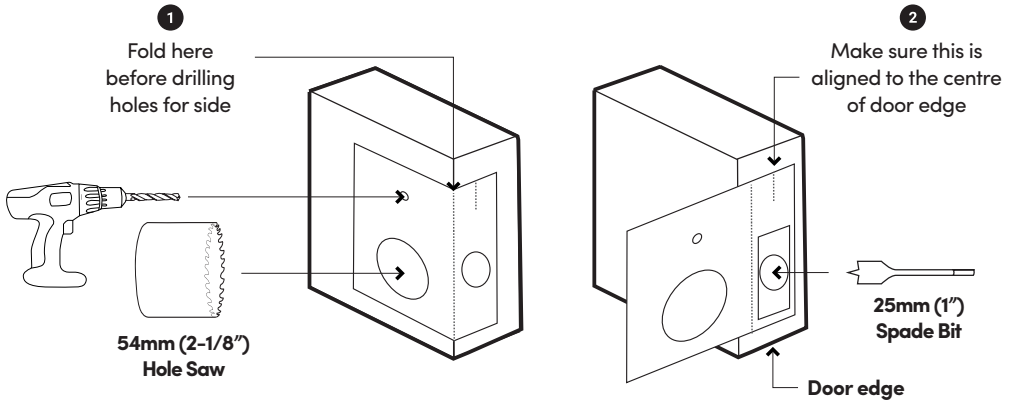

Chiselling

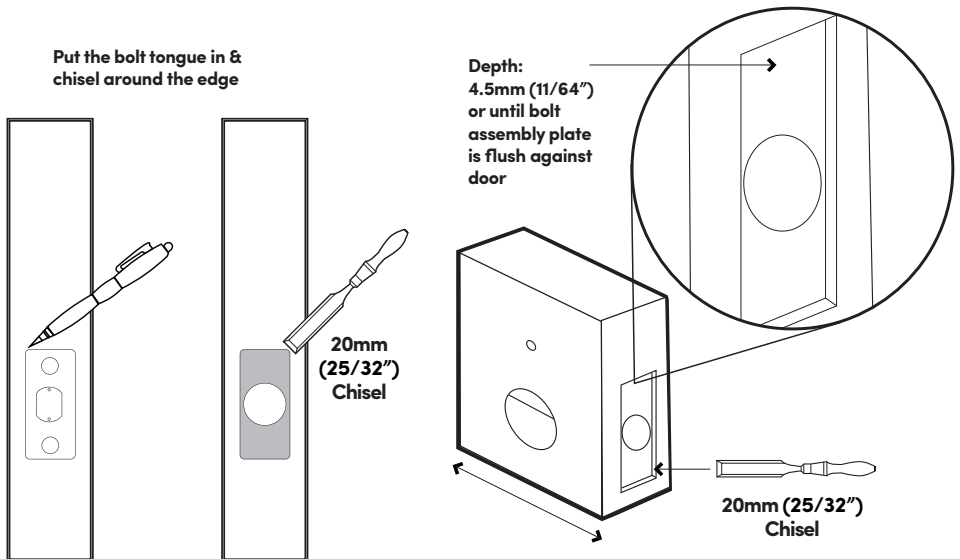

⚠ Mark the center of the holes and then drill for accuracy.

Prepare Lock For Installation

1 Set Back Assembly for Left / Right Installation

Left Installation

Set the toggle to 'L' for left-side installation.

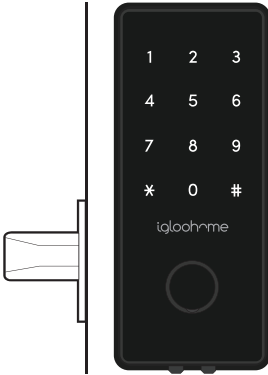

Right Installation

Set the toggle to 'R' for right-side installation.

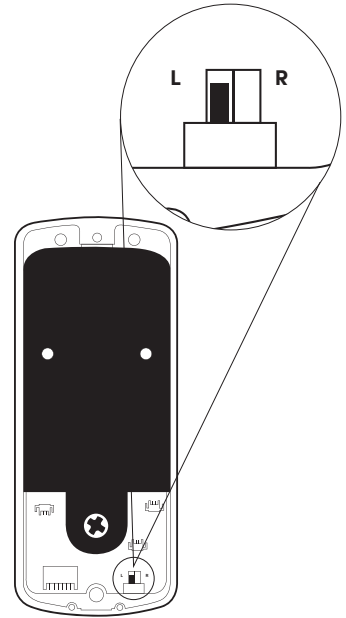
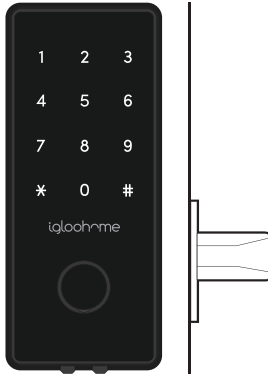

2 Remove Battery Cover from the Back Assembly

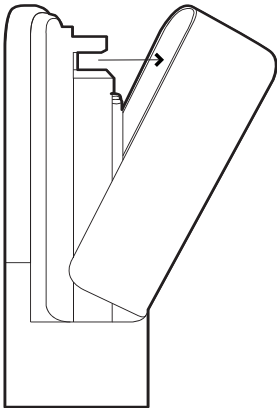

Top View of Battery Cover

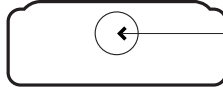

Press the button on the top of the battery cover, and pull outwards.

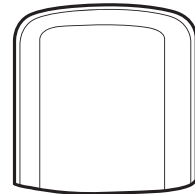
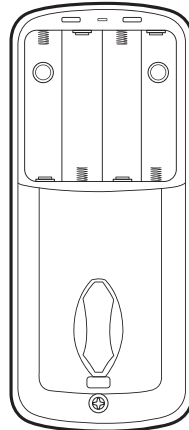

Installation Instructions

1 Measure

If you are replacing your current deadbolt lock, industry standards are 60mm (2-3/8") or 70mm (2-3/4") backset. To determine which backset length you should use, so measure the distance (x) between the center of 54mm (2-1/8") hole to door edge.

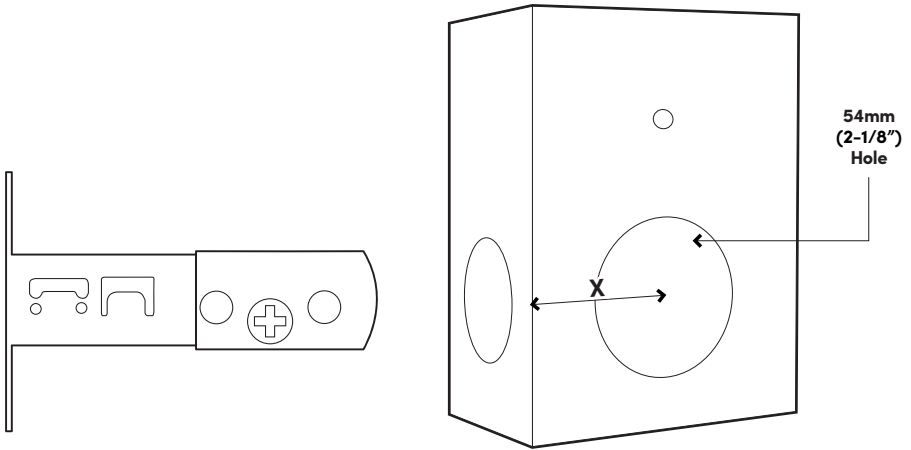

Prepare bolt assembly based on the distance (x)

Bolt ships with bolt assembly in 60mm (2-3/8") position. If required, twist the bolt and pull to extend (simultaneously) to 70mm (2-3/4") backset position.

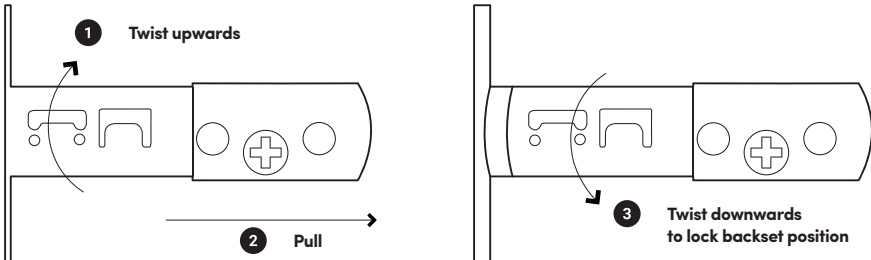

2 Insert bolt and front assembly into door edge

The '+' hole on the backset should be in the middle of the hole.

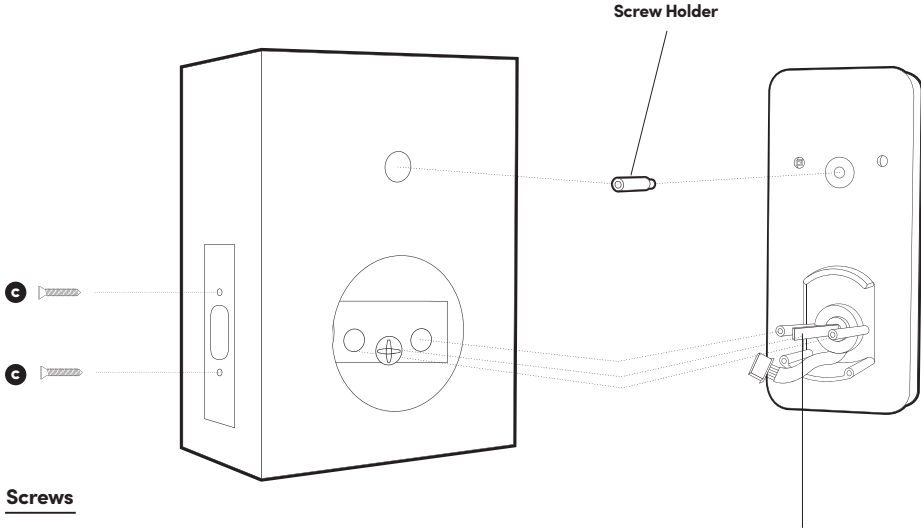

Screws

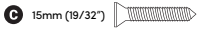

⚠ Please ensure that tailpiece is in vertical position.

3 Measure and cut the tailpiece if necessary

After inserting the tailpiece, measure the distance of protrusion from the door.

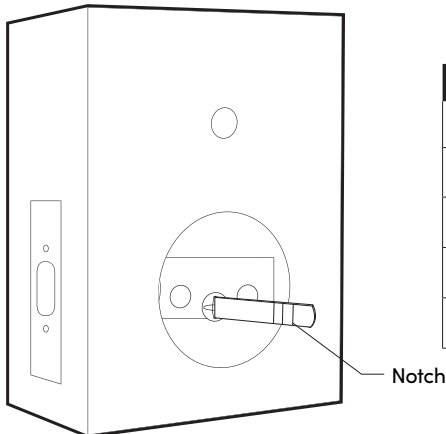

Door thickness (mm)	No. of notch to cut
60	0
55	1
45	2
40	3
35	4

⚠ The recommended tailpiece protrusion from the door is 15mm.

4**Secure the Front Assembly using the Back Plate.**

To do this, place the Back Plate (ensuring the correct side placement).

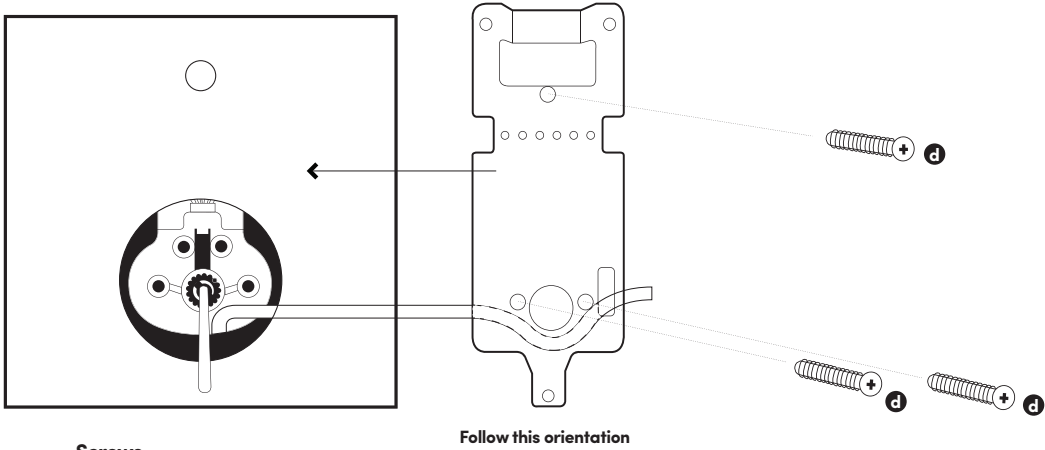
**Screws**

d 43mm (1-11/16") 

5**Door Sensor Installation**

Adjust the position of the door sensor according to the door handling (left or right installation).
Use the 2 x 5 (13/64) mm screws to secure the door sensor to the back plate.

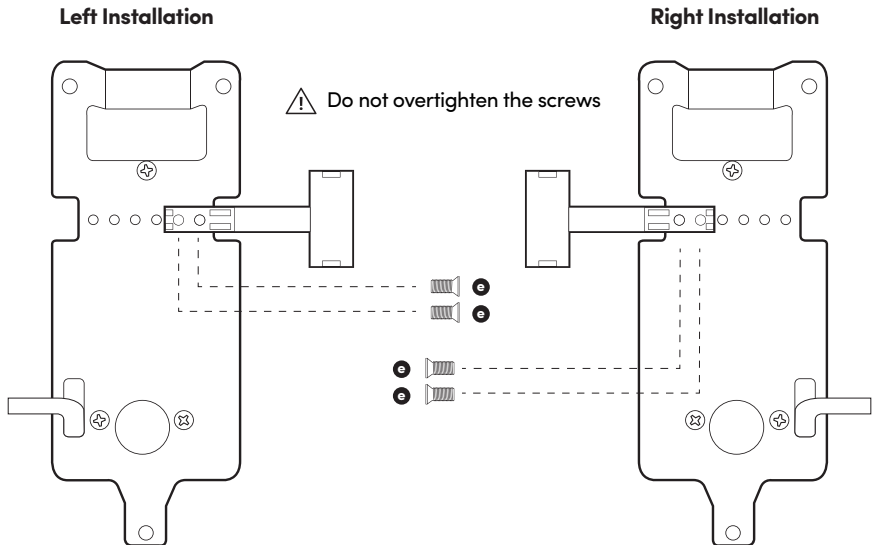
**Screws**

e 5mm (13/64") 

6**Fit in the Rubber Gasket**

Insert the front assembly cable through the rectangular hole on the rubber gasket. The hole should be on the right side of the rubber gasket.

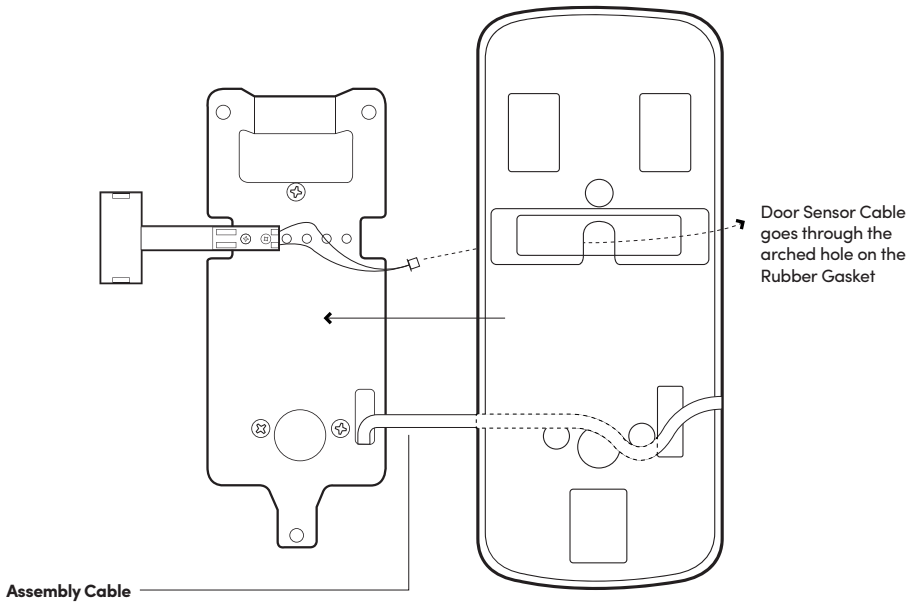
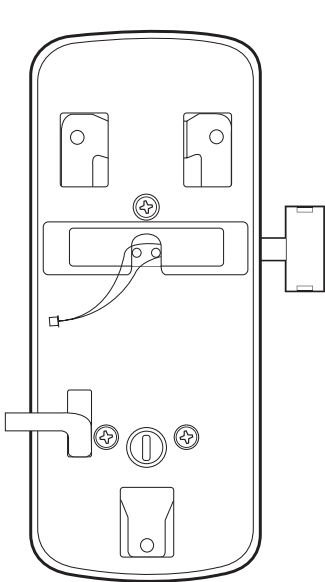
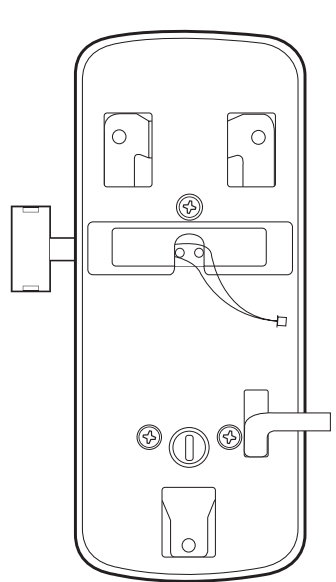
**Left Installation****Right Installation**

7 Connect Assembly Cable

Connect the sensor cable to the Back Assembly then connect the assembly cable from the Front assembly through the 54mm hole to the Back Assembly. Ensure that the wire is installed properly and securely.

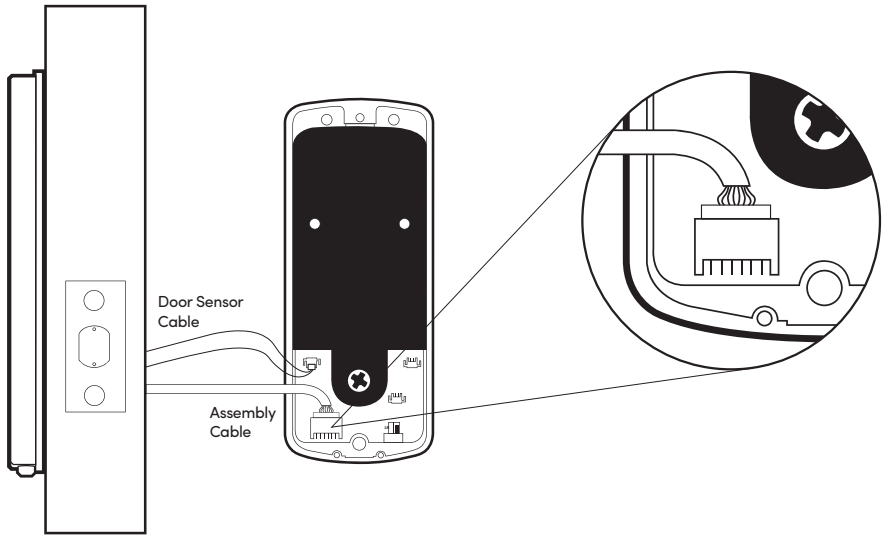

8 Fit Back Assembly to the Door Tailpiece

Ensure thumbturn position is turned to 'unlock' position.

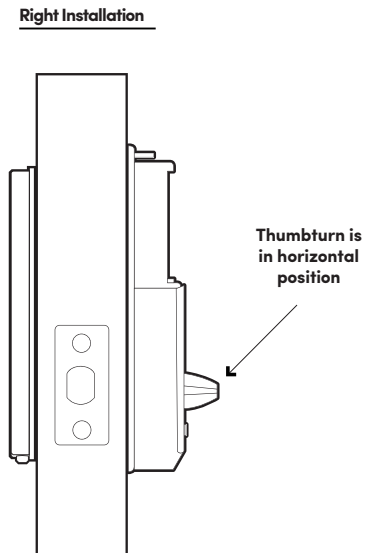
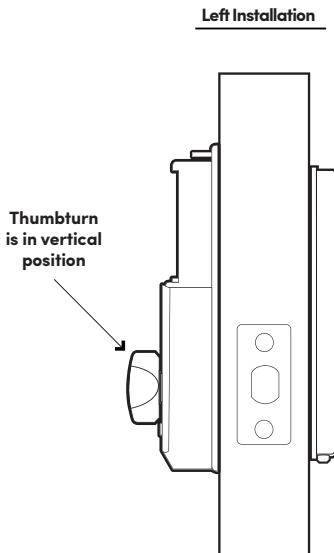

9 Secure the Back Assembly

⚠ Do not overtighten the screws

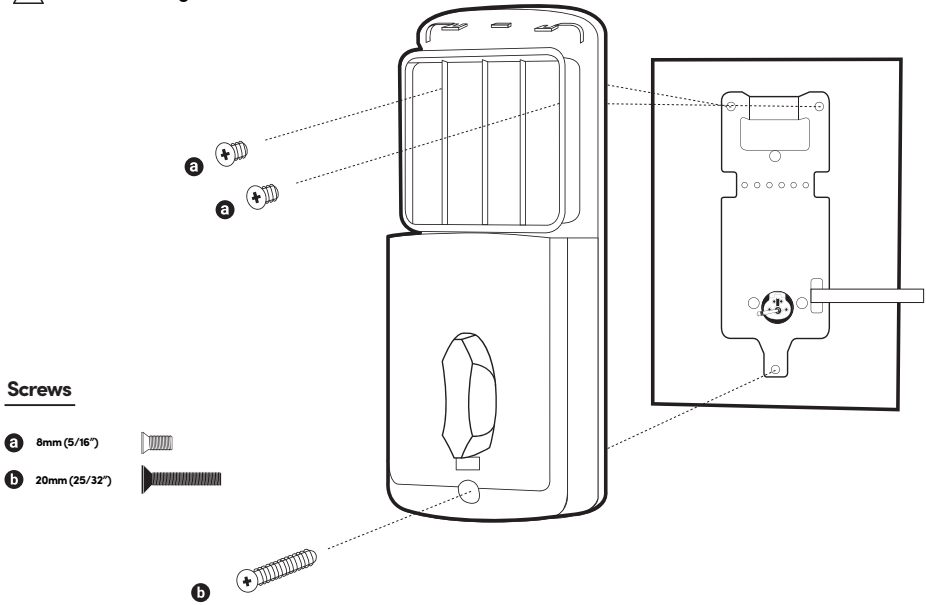

10 Insert 4 AA Alkaline Batteries and push the battery case lid inwards to close

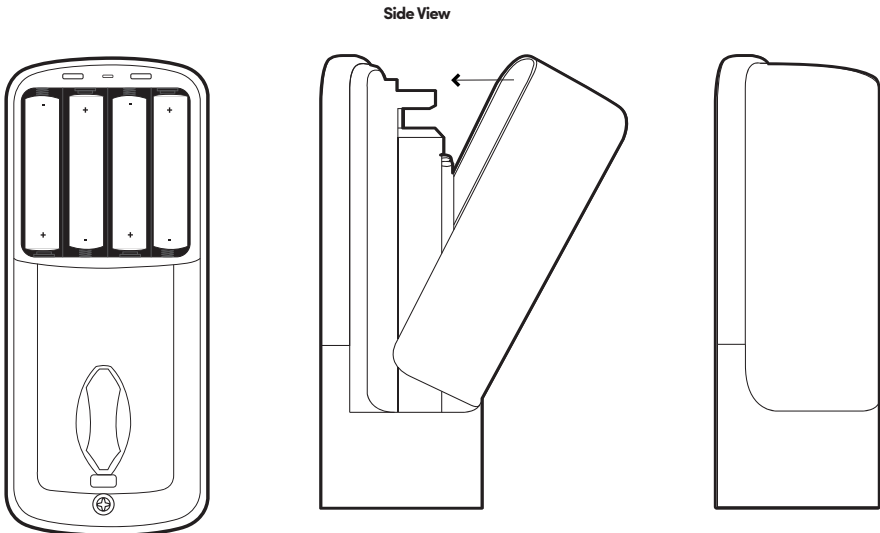

Test Lock

Place hand over your lock to activate touchpad and hold # to lock.

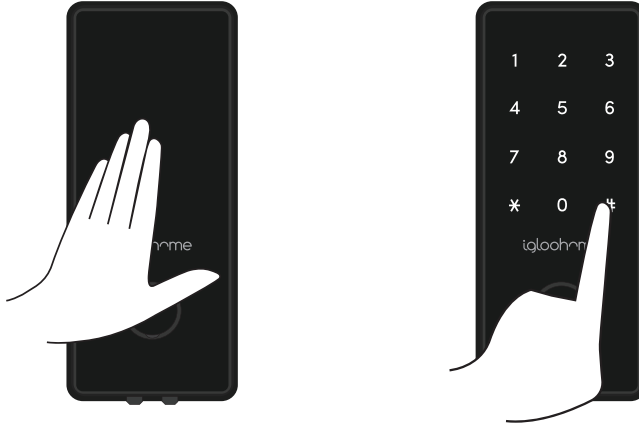

Does your bolt lock?

Yes

Congrats!
Your lock is correctly installed.
Proceed to next steps.

No

Bummer!
Does the bolt lock and unlock
when you turn the thumbturn?

Yes

**Left-Right toggle
incorrectly set**

Troubleshoot: Try Setting the
left-right toggle on your back
assembly to the correct side.
(See Pg. 10)

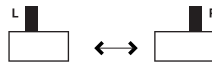

No

**Tailpiece and/or thumbturn
incorrectly set**

Troubleshoot: Disassemble lock
and install it again.

Still experiencing issues?
Go to igloohome.co/support for more help

Prepare the Door Frame

1 Ensure to align the lock to the door frame and mark it down.

2 Mark out where the bolt tongue locks then drill a corresponding hole on door frame. Chisel to fit the strike plate in as well.

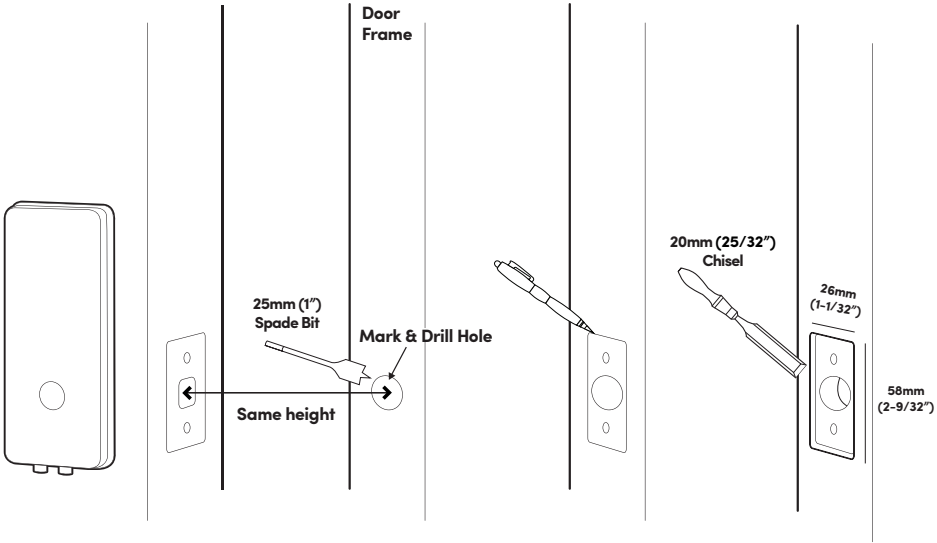

3 Secure strike plate housing and strike plate using 2x 25mm (1") wood screws.

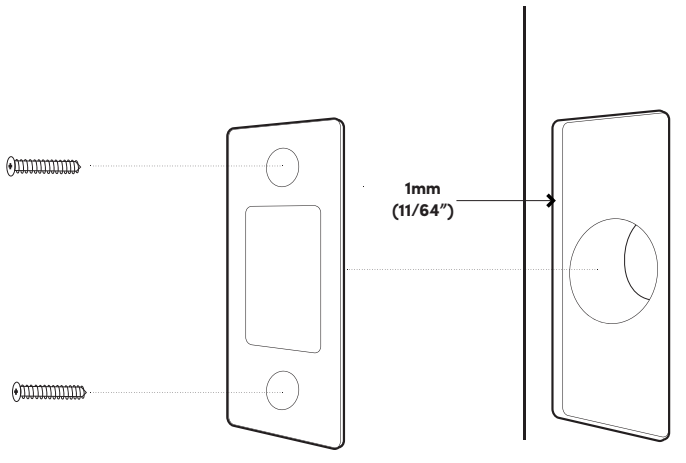

User Guide

Lock Anatomy

Outer Body

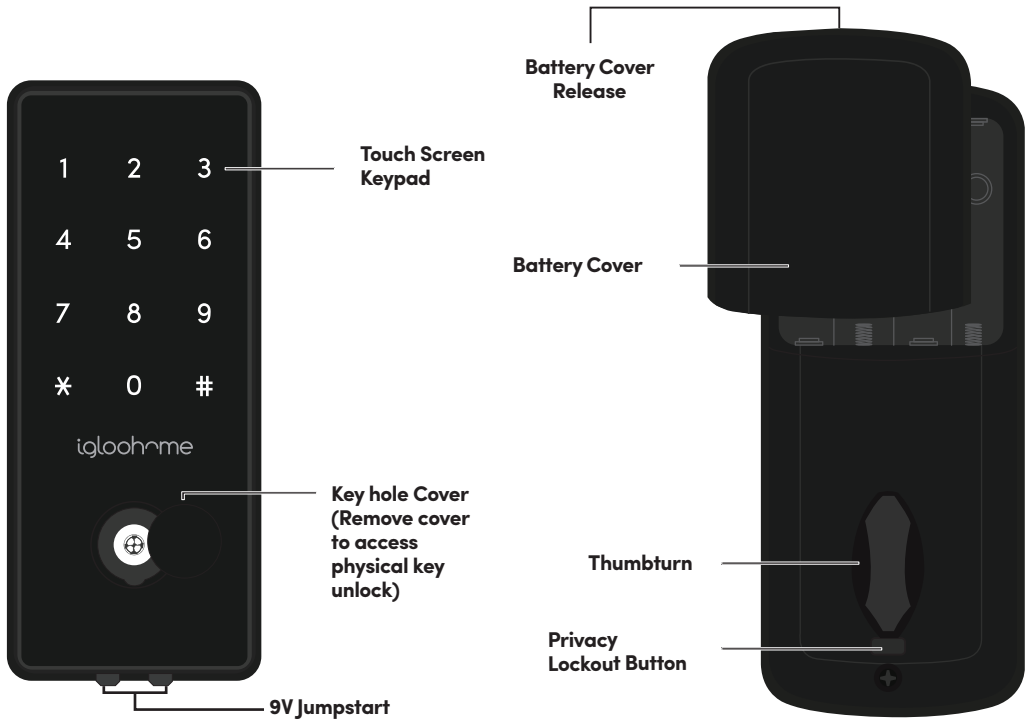

Features

PIN / Bluetooth Unlock



Bluetooth Master Key

The igloohome Smart Deadbolt 2S unlocks with Bluetooth via the app.



Master PIN Code

The igloohome Smart Deadbolt 2S unlocks with a permanent Master PIN Code.



Bluetooth Guest Key

Bluetooth keys based on duration can be generated and shared with guests.



User PIN Code

The mobile app can generate user PIN codes, with validity duration from One-Time, Permanent, or a Duration based on Date-time.

Lock



Timer Re-lock

After successfully unlocking, the igloohome Deadbolt 2S will re-lock after a period of time (between 5 to 120 seconds). The owner sets this function.



Sensor Re-lock (Recommended Accessory)

The Sensor detects when the door is closed and locks automatically.



Manual Locking

Hold the '#' key for 2 seconds to lock the igloohome Deadbolt 2S.

Features

Security / Alarms



Security Lockout Mode

After 5 consecutive unsuccessful attempts at entering a PIN code, the igloohome Smart Deadbolt 2S will be unresponsive for 5 minutes. Physical key and Bluetooth Unlock can be used to unlock in this state.



Privacy Lockout Mode

Activate this from indoors to prevent entry from outsiders. Physical key can be used to unlock in this state.



Decoy PIN Code

A total of 16 decoy digits including PIN code can be entered to prevent the PIN code from being exposed.



Activity Logs

Entry via PIN codes and Bluetooth Key will be logged in the app.

Bluetooth key access logs are updated in real-time and PIN code access logs are updated when the owner uses a bluetooth key or update logs.



Tamper Alarm

The lock will sound if intruders try to pry the lock from the door.

Battery



Emergency Jump-Start

If battery power is drained, an external 9 Volt battery can be used to provide emergency power. The 2 contact points of the battery must be aligned with the 2 contact points on the Deadbolt 2S.

Unlocking & Locking

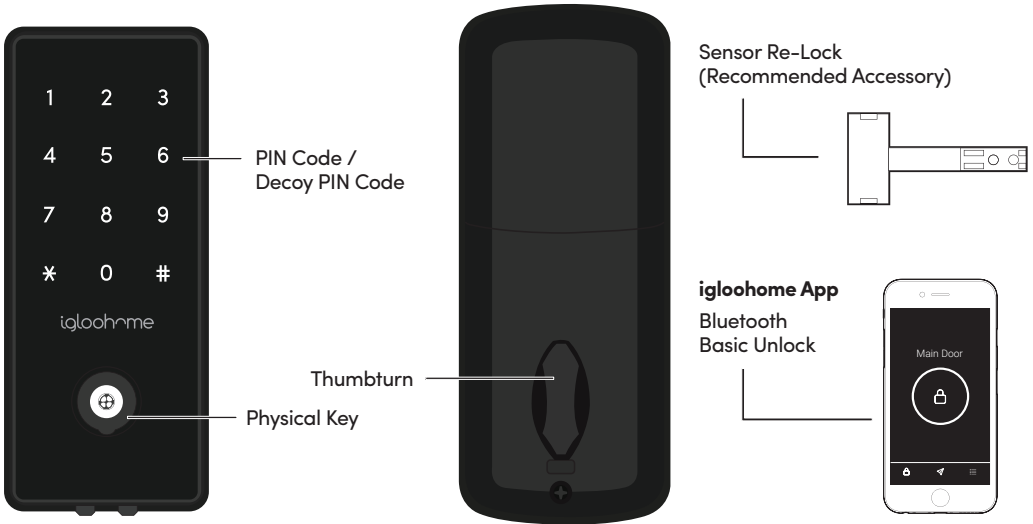

Unlocking



PIN Code

Key in your PIN code and press '#'



Bluetooth Basic Unlock

On your app, click on the Bluetooth Unlock button and tap on your lock



Thumbturn

Use thumbturn at the back of lock



Bluetooth Guest Key

Refer to page 23



Physical Key

Use the physical key to unlock the door

Locking



'#' Key

Press and hold '#'



Timer Re-Lock

Refer to page 24



Sensor Re-Lock (Recommended Accessory)

Automatic locking after door closes



Physical Key

Use the physical key to lock the door



Thumbturn

Use thumbturn at the back of lock

App Onboarding

1 Test Factory PIN Unlock

In the factory mode (before pairing), the PIN to unlock is * **1234567890** #

2 Register as a Lock User

a) Download *igloohome* from App store / Play store.

b) Create an account and login.

3 Pairing

a) Select **[Add new igloohome lock]**

Note: For existing users with other paired locks, go to **[Configuration]**, select **[Manage Locks]** followed by the **[Add]** icon.

a) Select **[igloohome Deadbolt 2S]**

b) Place your palm over keypad to wake device up

c) Press **[Next]** and select the lock to pair with

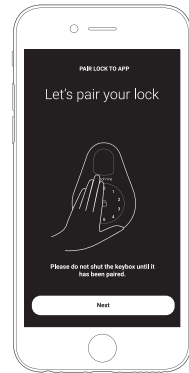

4 Setting Master PIN code

Before proceeding, turn on your Bluetooth and ensure that you are within Bluetooth range of the lock.

Go to **[Access]** and customize your **[Master PIN]** by editing it.

Managing Access in App

1 Creating PIN codes

PIN codes can be generated on the app under **[Access]**, create **[New Key]** and choose either One-Time, Permanent or Duration PIN.

Pin codes will expire if its not use within its activation period. Refer to the table below.

PIN Type	Use PIN within*
One-Time PIN	6 hrs of generation
Permanent PIN	24hrs of generation
Duration PIN	24hrs from the start time

2 Bluetooth Guest Key

Bluetooth Guest Key can be shared with other users for mobile access. It allows your guests to unlock the igloohome smart lock via Bluetooth.

There are 3 steps to using a Shared Bluetooth Key

- Under **[Access]**, create **[New Key]** and choose **[Bluetooth Key]** under **[Access Type]**. Proceed to share the key after it is created.
- Guest receives the Bluetooth Key by one of these methods:
 - Clicking the URL given and follow the instructions.
 - Scanning the QR code under **[Visits]**.
- Guest can now use the Bluetooth Key under **[Visits]** whenever he is within range of the lock.

Notes:

- The owner can revoke the Bluetooth Key in App.
- Bluetooth Key must be accepted within 1 hour generation before it expires.

3 Resetting PIN codes

Ensure that Bluetooth is switched on, and you are within Bluetooth range of the lock.

Go to Home > Select Lock Name > **[Settings]** > Reset Pins

Lock will reset all codes, except for Master PIN, and all PIN codes previously generated are no longer valid.

Lock Tutorial

1 Edit PIN codes

Once PIN code is generated, user must key the generated code onto the Deadbolt 2S keypad followed by # to activate the code before proceeding. To change the PIN, enter:

Press * > **Key 10** and tap # > Current PIN and tap # > **New 4 - 9 digit PIN** and tap # > **New 4 - 9 digit PIN** and tap #

Current PIN Code	1234 5678
New PIN Code	010101
On Keypad	Press * > Key 10 # > 1234 5678 # > 010101 # > 010101 #

Notes:

- Editing of codes can also be done in app
- PINs must be used once before it can be edited.

2 Enabling & Disabling Timer Re-Lock*

To Enable	* 2 1 # <Master PIN> # <Duration between 5-120 seconds> #
To Disable	* 2 0 # <Master PIN> #

Note: By default, Timer Re-lock is disabled.

3 9V Jumpstart Feature

Step 1 - Touch and hold the battery contacts against the 9V jumpstart pin on the lock and you will hear a series of beeps

Step 2 - While holding the 9V battery to the jumpstart, key in your PIN code on the keypad followed by '#' to unlock

Lock Behaviour

4 Security Lockout Mode

After 5 consecutive unsuccessful attempts at entering a PIN code, the igloohome Samrt Deadbolt 2S will be unresponsive for 5 minutes.

Note: Physical key and Bluetooth Unlock can be used to unlock in this mode.

5 Privacy Lockout Mode

Privacy Lockout Mode prevents others from using PIN code and Bluetooth Key to unlock when you are inside the property.

Note: Physical key can be used to unlock in this mode.

To activate Privacy Lockout Mode, press and hold Privacy Lockout button until the lock sound off.

Audio Indications:

- Long beep when activated.
- 2 quick beeps when disabled.

	Security Lockout Mode	Privacy Lockout Mode
Activated by	5 consecutive invalid PIN codes	Privacy Lockout button
Disable By	Wait for 5 Minutes Bluetooth Unlock	Privacy Lockout Button Physical Key Thumbturn
Behaviour	Keypad is flickering on touch	Keypad does not light up
Duration	Unresponsive for 5 minutes	Unresponsive until Privacy Lockout Mode is disabled

Airbnb Connect

1

Airbnb Connect

Airbnb Connect automates the generation of PIN codes for your Airbnb guests based on their approved reservations. It costs USD\$4.99 per month, but is currently on free trial.

Here are the steps to activate Airbnb Connect

Step 1: Connect to your Airbnb

Under **[Account Settings]**, select **[Connect with Airbnb]**

Step 2: Connect to Airbnb listings

Under **[Reservations]**, click the **[Add]** icon to select a home to connect to. Select Airbnb Listing and PIN Time to associate.

Note:

- Emails with PIN code will be sent to the guest between 1 to 48 hours before check-in time (configurable).
- PINs will only be valid between the check-in and check-out times.

Step 3: Change Check-in and Check-out time

Under **[Configuration]**, select **[Manage Homes]** followed by the listing to view or edit its details.

Notes:

- If the access mail has not been sent, changing your check-in/check-out time via the app modifies the start and end time of the PIN codes to be shared with your guest.
- If the access mail has been sent, changing these details will only affect the next reservation.
- Changing these details on the igloohome app does not update the check-in/check-out time on the listing on the Airbnb website.

2

Disconnect Airbnb

Should you prefer to generate PIN codes for your guests manually, you may disconnect your Airbnb listing from the igloohome home listing with the steps below.

1. Under **[Reservations]**, disconnect all the listings (if any).
2. Under **[Account Settings]**, select **[Disconnect with Airbnb]**.

Should you wish to completely disconnect your Airbnb account from your igloohome account, make sure that all your Airbnb listings have been disconnected in the above step, then go to:

Airbnb Host Website > Connected Apps > Select igloohome to disconnect

Troubleshoot

Pairing is unsuccessful

- Try with a different mobile device, using the same username and password
- Update your phone's Operating system to the latest version
- Restart the Bluetooth and internet connection on your mobile device
- Restart igloohome app on your mobile device
- Switch to a new set of batteries

Keypad does not light up

- Use a 9V battery to jumpstart and switch to a new set of batteries
- Check if the Deadbolt 2S is in Privacy Lockout Mode

Keypad is flickering

- The Deadbolt 2S is low in battery. Switch to a new set of batteries

Generated PIN codes do not work

- Make sure that the generated PIN codes are activated within the given hours
- Do a Bluetooth Unlock to refresh the app
- PIN codes may have been customised or expired

Changing Batteries

- To open the battery compartment, press the button on the top of the battery cover and tilt the cover downwards to open
- Replace all four batteries

Lock is not working when battery level is not 100%

- Do a Bluetooth Key unlock to refresh the battery level on the app
 - Battery level shown in the app may not be accurate
 - Use Alkaline batteries only
 - Do not use: Heavy Duty, Eveready, GP, or rechargeable batteries
- * Using high quality batteries will improve the performance and lifespan of the lock

Bluetooth Key is not working

- Restart the Bluetooth and internet connection on your mobile device
- Check on the timezone of the home listing against your phone time
- Check if the Bluetooth Key is expired. It must be accepted within 1 hour of generation
- Update your igloohome app to the latest version
- Switch to a new set of batteries

Re-lock is not working

- Check battery level of the lock
- Make sure you have enabled timer re-lock

Keypad lights up on touch only

- Check if the Deadbolt 2S is in security lockout mode
- Refer to Lock Tutorial - Step 4

For enquiries go to:
igloohome.co/support