

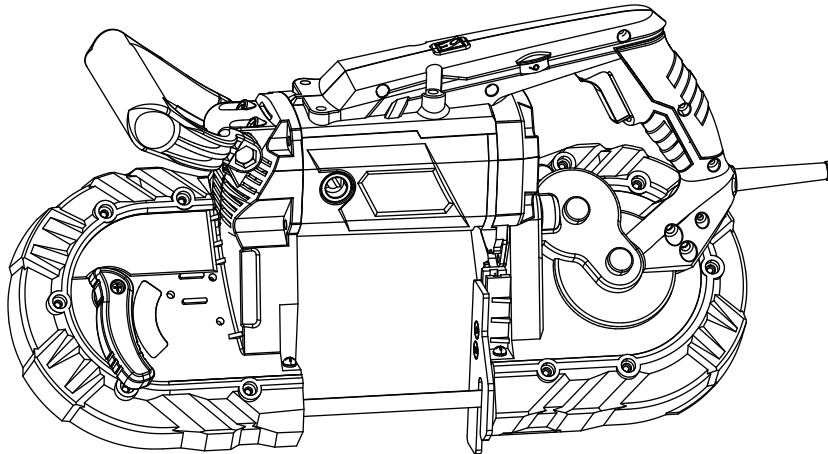

PORTABLE BAND SAW



For replacement parts visit
WENPRODUCTS.COM

Model #94396
bit.ly/wenvideo

IMPORTANT:

Your new tool has been engineered and manufactured to WEN's highest standards for dependability, ease of operation, and operator safety. When properly cared for, this product will supply you years of rugged, trouble-free performance. Pay close attention to the rules for safe operation, warnings, and cautions. If you use your tool properly and for its intended purpose, you will enjoy years of safe, reliable service.



NEED HELP? CONTACT US!

Have product questions? Need technical support?
Please feel free to contact us at:

 **800-232-1195** (M-F 8AM-5PM CST)

 techsupport@wenproducts.com

 **WENPRODUCTS.COM**

NOTICE: Please refer to wenproducts.com for the most up-to-date instruction manual.

TABLE OF CONTENTS

Product Specifications	2
Safety Introduction.....	3
General Safety Rules	4
Specific Rules for Your Band Saw.....	6
Electrical Information.....	8
Know Your Portable Band Saw	9
Preparation & Adjustments	10
Operation.....	11
Maintenance	12
Troubleshooting	13
Exploded View & Parts List	14
Warranty Statement	16

PRODUCT SPECIFICATIONS

Model Number:	94396
Motor:	AC 120V, 60Hz, 10A, S1
Blade Speed:	60 to 420 FPM
Blade Dimensions:	44-7/8"(L) x 1/2"(W) x 0.025"(Thickness) 10/14 TPI
Cutting Capacity:	5 x 5 in.
Product Dimensions:	20-1/4 x 13 x 8-1/4 in.
Product Net Weight:	14.5 lbs

Replacement band saw blades (Part No. 94396B) and other replacement parts can be purchased from wenproducts.com

SAFETY INTRODUCTION

Thanks for purchasing the WEN Portable Band Saw. We know you are excited to put your tool to work, but first, please take a moment to read through the manual. Safe operation of this tool requires that you read and understand this operator's manual and all labels affixed to the tool. This manual provides information regarding potential safety concerns, as well as helpful assembly and operating instructions for your tool.



SAFETY ALERT SYMBOL: Indicates danger, warning, or caution. The safety symbols and the explanations with them deserve your careful attention and understanding. Always follow the safety precautions to reduce the risk of fire, electric shock and personal injury. However, please note that these instructions and warnings are not substitutes for proper accident prevention measures.

NOTE: The following safety information is not meant to cover all possible conditions and situations that may occur. WEN reserves the right to change this product and specifications at any time without prior notice.

Keep this manual available to all users during the entire life of the tool and review it frequently to maximize safety for both yourself and others.

GENERAL SAFETY RULES



WARNING! Read all safety warnings and instructions. Failure to follow all instructions may result in electric shock, fire and serious injury. The term “power tool” in the warnings refers to your mains-operated (corded) power tool. **Save all warnings and instructions for future reference.**

WORK AREA SAFETY

1. Keep work area clean and well lit. Cluttered or dark areas invite accidents.
2. Do not operate power tools in explosive atmospheres, such as in the presence of flammable liquids, gases or dust. Power tools create sparks which may ignite the dust or fumes.
3. Keep children and bystanders away while operating a power tool. Distractions can cause you to lose control.

ELECTRICAL SAFETY

1. Power tool plugs must match the outlet. Never modify the plug in any way. Do not use any adapter plugs with earthed (grounded) power tools. Unmodified plugs and matching outlets will reduce risk of electric shock.
2. Avoid body contact with earthed or grounded surfaces such as pipes, radiators, ranges and refrigerators. There is an increased risk of electric shock if your body is earthed or grounded.
3. Do not expose power tools to rain or wet conditions. Water entering a power tool will increase the risk of electric shock.
4. Do not abuse the cord. Never use the cord for carrying, pulling or unplugging the power tool. Keep cord away from heat, oil, sharp edges or moving parts. Damaged or entangled cords increase the risk of electric shock.
5. When operating a power tool outdoors, use an extension cord suitable for outdoor use. Use of a cord suitable for outdoor use reduces the risk of electric shock.
6. If operating a power tool in a damp location is unavoidable, use a ground fault circuit interrupter (GFCI) protected supply. Use of a GFCI reduces the risk of electric shock.

PERSONAL SAFETY

1. Stay alert, watch what you are doing and use common sense when operating a power tool. Do not use a power tool while you are tired or under the influence of drugs, alcohol or medication. A moment of inattention while operating power tools may result in serious personal injury.
2. Use personal protective equipment. Always wear eye protection. Protective equipment such as a dust mask, non-skid safety shoes, work gloves and hearing protection used for appropriate conditions will reduce the risk of personal injury.
3. Prevent unintentional starting. Ensure the switch is in the off-position before connecting to power source and/or battery pack, picking up or carrying the tool. Carrying power tools with your finger on the switch or energizing power tools that have the switch on invites accidents.
4. Remove any adjusting key or wrench before turning the power tool on. A wrench or a key left attached to a rotating part of the power tool may result in personal injury.

GENERAL SAFETY RULES

5. Do not overreach. Keep proper footing and balance at all times. This enables better control of the power tool in unexpected situations.
6. Dress properly. Do not wear loose clothing or jewelry. Keep your hair, clothing and gloves away from moving parts. Loose clothes, jewelry or long hair can be caught in moving parts.
7. If devices are provided for the connection of dust extraction and collection facilities, ensure these are connected and properly used. Use of dust collection can reduce dust-related hazards.

POWER TOOL USE AND CARE

1. Do not force the power tool. Use the correct power tool for your application. The correct power tool will do the job better and safer at the rate for which it was designed.
2. Do not use the power tool if the switch does not turn it on and off. Any power tool that cannot be controlled with the switch is dangerous and must be repaired.
3. Disconnect the plug from the power source and/or the battery pack from the power tool before making any adjustments, changing accessories, or storing power tools. Such preventive safety measures reduce the risk of starting the power tool accidentally.
4. Store idle power tools out of the reach of children and do not allow persons unfamiliar with the power tool or these instructions to operate the power tool. Power tools are dangerous in the hands of untrained users.
5. Maintain power tools. Check for misalignment or binding of moving parts, breakage of parts and any other condition that may affect the power tool's operation. If damaged, have the power tool repaired before use. Many accidents are caused by poorly maintained power tools.
6. Use the power tool, accessories and tool bits etc. in accordance with these instructions, taking into account the working conditions and the work to be performed. Use of the power tool for operations different from those intended could result in a hazardous situation.

SERVICE

Have your power tool serviced by a qualified repair person using only identical replacement parts. This will ensure that the safety of the power tool is maintained.

CALIFORNIA PROPOSITION 65 WARNING

Some dust created by power sanding, sawing, grinding, drilling, and other construction activities may contain chemicals, including lead, known to the State of California to cause cancer, birth defects, or other reproductive harm. Wash hands after handling. Some examples of these chemicals are:

- Lead from lead-based paints.
- Crystalline silica from bricks, cement, and other masonry products.
- Arsenic and chromium from chemically treated lumber.

Your risk from these exposures varies depending on how often you do this type of work. To reduce your exposure to these chemicals, work in a well-ventilated area with approved safety equipment such as dust masks specially designed to filter out microscopic particles.

SPECIFIC RULES YOUR BAND SAW



WARNING: Do not let comfort or familiarity with the product replace strict adherence to product safety rules. Failure to follow the safety instructions may result in serious personal injury.

- 1. WORK ENVIRONMENT.** Do not operate the tool in wet or damp conditions; doing so significantly increases the risk of electrical shock. Do not operate the tool in the presence of flammable liquids or gases; sparks generated by the grinder could ignite these flammable materials.
- 2. PREVENTING ELECTRIC SHOCK.** Hold power tool by insulated gripping surfaces, when performing an operation where the cutting accessory may contact hidden wiring or its own cord. Cutting accessories contacting a “live” wire may make exposed metal parts of the power tool “live” and could give the operator an electric shock.
- 3. PERSONAL SAFETY.** Tie back long hair. Do not wear loose clothing or jewelry as they might get drawn in by the tool. Always wear ANSI Z87.1-approved glasses with side shields, hearing protection and a dust mask when using the tool.
- 4. DUST PROTECTION.** Wear a dust mask and work with a dust extraction device. Dust from material such as paint containing lead, some wood species, minerals and metal may be harmful (contact with or inhalation of the dust may cause allergic reactions and/or respiratory diseases to the operator or bystanders); certain kinds of dust are classified as carcinogenic (such as oak and beech dust) especially in conjunction with additives for wood conditioning.
- 5. SAW BLADE SAFETY.** Use the correct size and style of blade. Inspect blades for cracks and missing teeth before each use. Do not operate with dull, cracked or badly worn blade. When replacing blades, make sure the blade teeth are pointing down and towards the table. Check that the blade is properly tensioned (blade tensioning handle tightened down) before operating.
- 6. WORKPIECE SAFETY.** Workpieces should be securely fastened down so they don’t twist, rock, or slip while being cut. Small pieces should be secured with clamps or fixtures. Do not hold small pieces with your hand. Work slowly and carefully when cutting corners, sharp edges, ragged welds, and etc. to avoid snagging.
- 7. STARTING THE TOOL.** Hold the tool firmly with both hands to resist starting torque. Turn on the tool and let the blade come to full speed before contacting the workpiece.
- 8. DURING OPERATION.** To prevent personal injury, maintain a firm grip on the tool with both hands and keep the tool away from your body. Keep hands, hair and other beloved body parts away from the blade. Do not run the tool while carrying it at your side. Never leave the band saw unattended while it is running.
- 9. PREVENT BURNING.** Cutting material and the motor housing can get very hot during operation. Do not touch the workpiece, saw blade or motor housing immediately after operation.
- 10. TURNING OFF THE TOOL.** Lift the tool from the workpiece before turning the machine off. Do not put the band saw down until the blade comes to a complete stop. Moving parts can grab the surface and pull the tool out of your control. Turn off the tool, and unplug it from its electrical outlet before leaving.
- 11. MAINTAINING AND MAKING ADJUSTMENTS.** Always turn OFF and unplug the tool before cleaning, making adjustments or changing attachments. Accidental start-ups may occur if the tool is plugged in during an accessory change or adjustment.

SPECIFIC RULES YOUR BAND SAW

KICKBACK AND RELATED WARNINGS

Kickback is a sudden reaction to a pinched or snagged rotating wheel, backing pad, brush or any other accessory. Pinching or snagging causes rapid stalling of the rotating accessory which in turn causes the uncontrolled power tool to be forced in the direction opposite of the accessory's rotation at the point of the binding.

Kickback is the result of power tool misuse and/or incorrect operating procedures or conditions and can be avoided by taking proper precautions as given below.

1. Maintain a firm grip on the power tool and position your body and arm to allow you to resist kickback forces. Always use auxiliary handle, if provided, for maximum control over kickback or torque reaction during start-up. The operator can control torque reactions or kickback forces, if proper precautions are taken.
2. Never place your hand near the rotating accessory. The accessory may kick back over your hand.
3. Do not position your body in the area where power tool will move if kickback occurs. Kickback will propel the tool in the direction opposite to the wheel's movement at the point of snagging.
4. Use special care when working corners, sharp edges etc. Avoid bouncing and snagging the accessory. Corners, sharp edges or bouncing have a tendency to snag the rotating accessory and cause loss of control or kickback.

VIBRATION SAFETY

This tool vibrates during use. Repeated or long-term exposure to vibration may cause temporary or permanent physical injury, particularly to the hands, arms and shoulders. To reduce the risk of vibration-related injuries:

1. First be examined by a doctor and then have regular medical check-ups to ensure medical problems are not being caused or worsened from using this tool. People who are pregnant, have impaired blood circulation to the hand, past hand injuries, nervous system disorders, diabetes, or Raynaud's disease should NOT use this tool.
2. If you feel any symptoms related to vibration (such as tingling, numbness, and white or blue fingers), stop working and seek medical advice as soon as possible.
3. Do not smoke during use. Nicotine reduces the blood supply to the hands and fingers, increasing the risk of vibration-related injury.
4. Wear suitable work gloves to reduce the effects of vibration.
5. Hold the tool firmly enough to keep safe control of it, but NOT too tightly. The risk associated with vibration is increased when the gripping force is high. Let the tool do the work.
6. Take vibration-free breaks during each day of work.

These safety instructions can't possibly warn of every scenario that may arise with this tool, so always make sure to stay alert and use common sense during operation.

ELECTRICAL INFORMATION

DOUBLE-INSULATED TOOLS

The tool's electrical system is double insulated where two systems of insulation are provided. This eliminates the need for the usual three-wire grounded power cord. Double insulated tools do not need to be grounded, nor should a means for grounding be added to the product. All exposed metal parts are isolated from the internal metal motor components with protecting insulation.

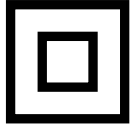

IMPORTANT: Servicing a double-insulated product requires extreme care and knowledge of the system, and should be done only by a qualified service personnel using identical replacement parts. Always use original factory replacement parts when servicing.

- 1. POLARIZED PLUGS.** To reduce the risk of electric shock, this equipment has a polarized plug (one blade is wider than the other). This plug will fit in a polarized outlet only one way. If the plug does not fit fully in the outlet, reverse the plug. If it still does not fit, contact a qualified electrician to install a proper outlet. **DO NOT** modify the machine plug or the extension cord in any way.
- 2. GROUND FAULT CIRCUIT INTERRUPTER PROTECTION (GFCI)** should be provided on the circuit or outlet used for this power tool to reduce the risk of electric shock.
- 3. SERVICE AND REPAIR.** To avoid danger, electrical appliances must only be repaired by qualified service technician using original replacement parts.



WARNING: To avoid electrocution, **DO NOT** use in wet or damp areas or expose to rain.

GUIDELINES FOR USING EXTENSION CORDS

When using an extension cord, be sure to use one heavy enough to carry the current your product will draw. An undersized cord will cause a drop in line voltage resulting in loss of power and overheating. The table below shows the correct size to be used according to cord length and nameplate ampere rating. When in doubt, use a heavier cord. The smaller the gauge number, the heavier the cord.

AMPERAGE	REQUIRED GAUGE FOR EXTENSION CORDS			
	25 ft.	50 ft.	100 ft.	150 ft.
10A	18 gauge	16 gauge	14 gauge	12 gauge

1. Examine extension cord before use. Make sure your extension cord is properly wired and in good condition. Always replace a damaged extension cord or have it repaired by a qualified person before using it.
2. Do not abuse extension cord. Do not pull on cord to disconnect from receptacle; always disconnect by pulling on plug. Disconnect the extension cord from the receptacle before disconnecting the product from the extension cord. Protect your extension cords from sharp objects, excessive heat and damp/wet areas.
3. Use a separate electrical circuit for your tool. This circuit must not be less than a 12-gauge wire and should be protected with a 15A time-delayed fuse. Before connecting the motor to the power line, make sure the switch is in the OFF position and the electric current is rated the same as the current stamped on the motor nameplate. Running at a lower voltage will damage the motor.

KNOW YOUR PORTABLE BAND SAW

Carefully remove the tool and all contents from the packaging. Check all components against the diagram below. If any part is damaged or missing, please contact our customer service at (800) 232-1195, M-F 8-5 CST or email us at techsupport@wenproducts.com. Do not discard the packaging until the sander is completely assembled.

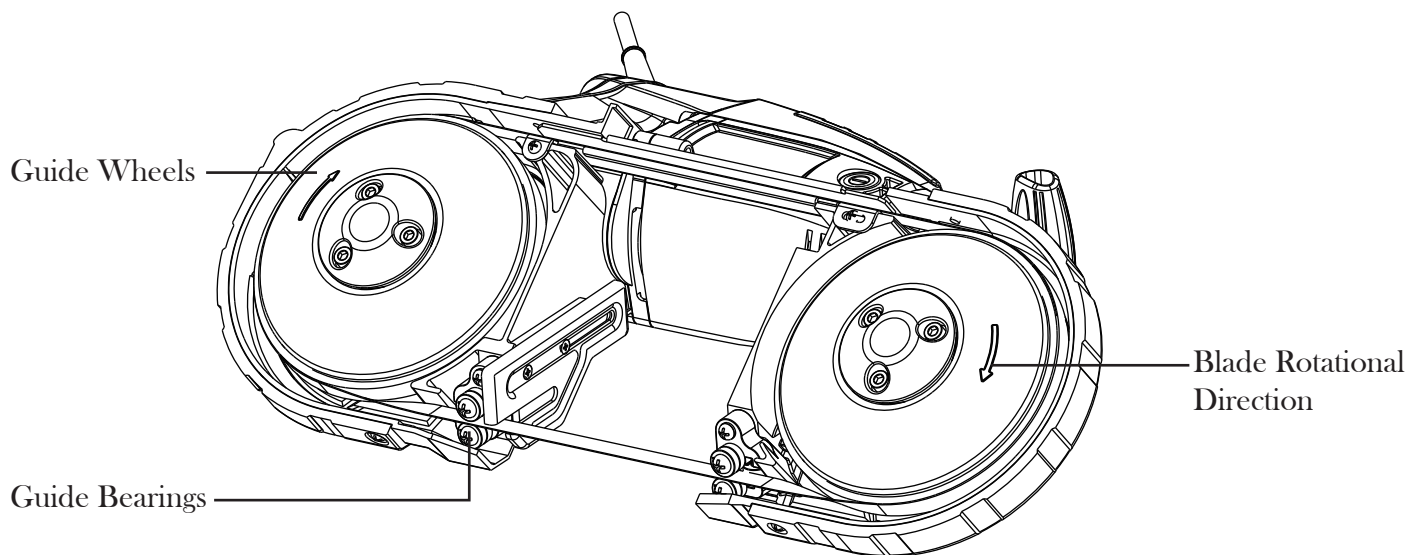
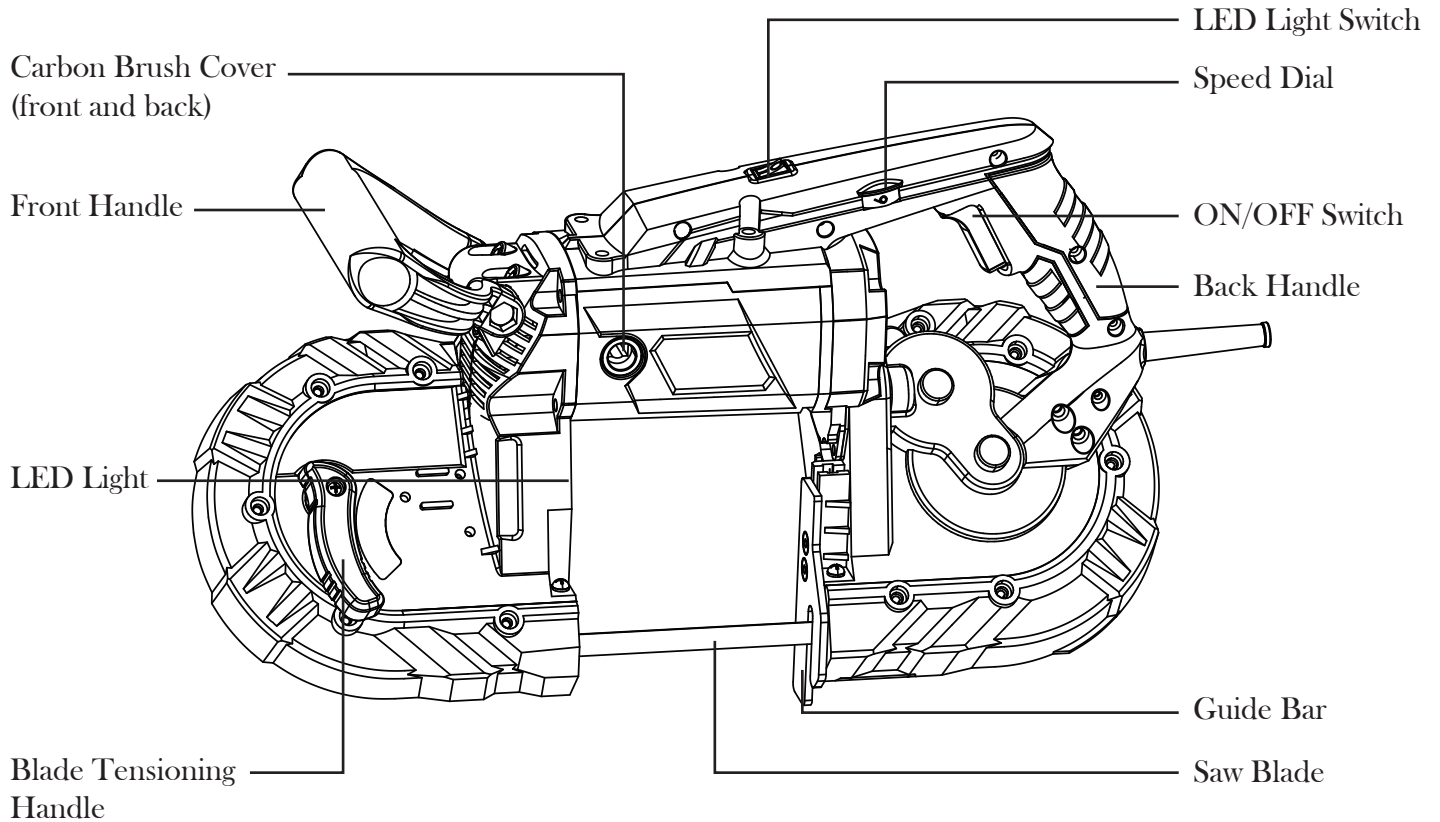

PREPARATION & ADJUSTMENTS



WARNING: To prevent injury from accidental operation, turn OFF and unplug the tool from the power source before assembling or making any adjustments to the tool.

INSTALLING/REMOVING SAW BLADE

Your band saw is designed to fit saw blades 44-7/8" long, 1/2" wide and 0.025" thick. Use the correct-sized blade that is suitable for the material to be cut. A 10/14 TPI saw blade with is included with your saw (pre-installed). Replacement blades can be ordered from wenproducts.com by searching the part number 94396B.



WARNING: Saw blades are sharp. Wear work gloves and safety goggles while handling the blades. Inspect blades for cracks and missing teeth before each use.

To install the blade:

1. Turn the tension handle (Fig. 1 - 1) on the front side of your saw clockwise to release the blade tension.
2. Flip the saw over to the back side. Hold the saw blade with the blade teeth facing towards you, and insert it between the two sets of guide bearings (Fig. 2 - 1). Make sure the blade is fully seated between the guide bearings - the spine of the blade should be in contact with the rear thrust bearing.
3. Guide the blade around the two guide wheels and press it inwards. Make sure the blade fits evenly around the wheels.
4. Turn the tension handle (Fig. 1 - 1) counterclockwise all the way until the handle is tight. The blade is now properly tensioned.
5. Put on eye and hearing protection, and hold the tool away from your body. Plug in and run the tool with no load for a few minutes to inspect the blade and allow it to seat properly. Make sure the blade runs evenly and steadily around the guide wheels.

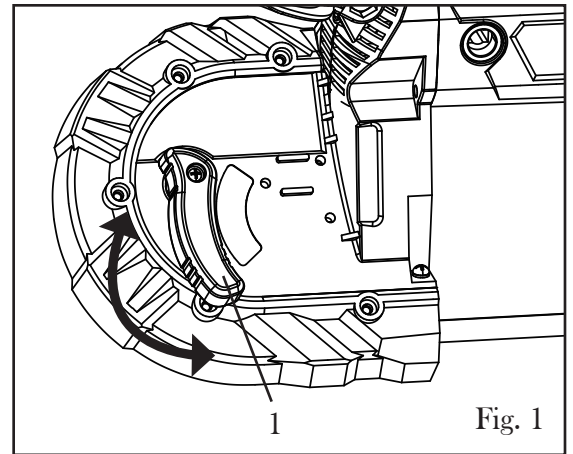

Fig. 1

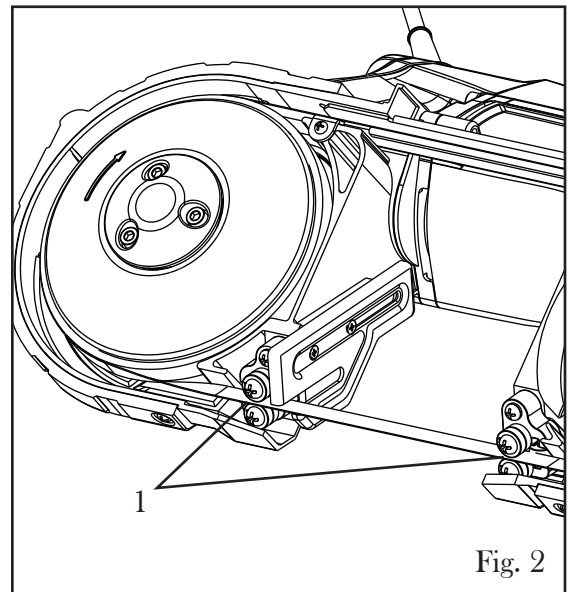

Fig. 2

To remove the blade:

1. Make sure the saw is switched off and the power is disconnected.
2. Turn the tension handle (Fig. 1 - 1) clockwise to release blade tension.
3. Wearing work gloves and safety goggles, carefully slide the blade off the top of the guide wheels and remove it from the guide bearings.

NOTE: If the saw is not being used for a long time, release tension and remove the saw blade before storage. This will prolong the life of the blade.

OPERATION

WORK AREA & WORKPIECE SET UP

1. Designate a work area that is clean and well lit. The work area must not allow access by children or pets to prevent distraction and injury. Do not operate in wet environment or near flammable materials.
2. Use suitable detectors to find hidden utility lines or call the local utility company for assistance. Contact with electric lines can lead to fire or electrical shock; damaging a gas line can result in an explosion; penetrating a water pipe will cause property damage or an electrical shock.
3. Route the power cord along a safe route to reach the work area without creating a tripping hazard or exposing the power cord to possible damage by the saw. The power cord must reach the work area with enough extra length to allow free movement while working.
4. Secure loose workpieces using a vise or clamps (not included) to prevent movement while working. Do not work materials containing asbestos (asbestos is considered carcinogenic). Dust from material such as paint containing lead, some wood species, minerals and metal may be harmful (contact with or inhalation of the dust may cause allergic reactions and/or respiratory diseases to the operator or bystanders). Wear a dust mask and work with a dust extraction device to reduce the risk of personal injuries from saw dust.

OPERATION

1. Hold the tool firmly with both hands on the insulated handles. With the workpiece secured, set the guide bar (Fig. 3 - 4) against the workpiece, keeping blade at a 90° angle to the workpiece.
2. Press the ON/OFF trigger (Fig. 3 - 1) to turn on the band saw. Use the speed dial (Fig. 3 - 2) to set the blade speed to a suitable value. The blade runs between 60 - 420 feet per minute. You can turn on the LED light to illuminate the cutting area using the LED light switch (Fig. 3 - 3).
3. Wait a few seconds to allow the blade to reach full speed before starting the cut.



WARNING: The blade is exposed on the underside of the saw; hold the band saw away from your body.

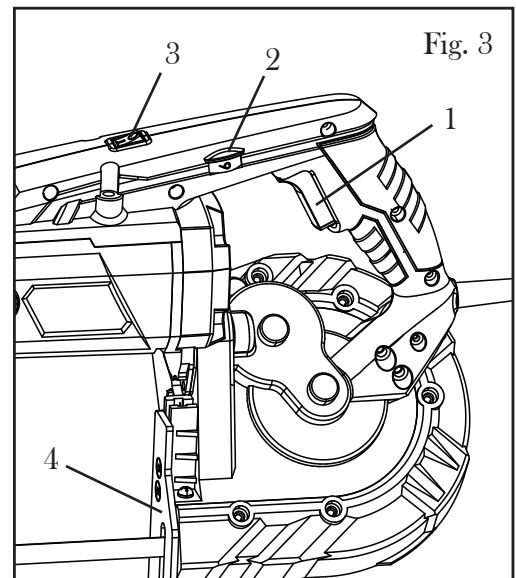

4. To start a cut, use minimal force to guide the blade into the workpiece to create a groove. Then, allow the rest of the blade to cut into the workpiece. Guide the tool to prevent blade from moving from side-to-side during cutting.

NOTE: Do not apply too much force on the tool. The weight of the tool itself will create enough force to make the cut; let the tool do the work. Forcing or leaning on the tool may twist or break the blade, damaging the saw and possibly causing injury.

5. As you reach the end of your workpiece, finish off the cut by slowly raising the tool slightly, bringing the blade up and away from the workpiece. Be careful to keep your feet clear of where the cut-off piece will fall.
6. Turn off and wait for the blade to stop. Do not put the tool down until it has come to a complete stop. Moving parts can grab the surface and pull the tool out of your control. Unplug the power plug, clean, then store the tool indoors out of the reach of children.

MAINTENANCE



WARNING: To avoid accidents, make sure the power switch is in the OFF position and unplug the tool from the electrical outlet before cleaning or performing any maintenance. Servicing of the tool must be performed by a qualified technician.

GENERAL MAINTENANCE

1. Before each use, inspect the general condition of the tool. Check for:

- Loose hardware,
- Misalignment or binding of moving parts,
- Damaged cord/electrical wiring,
- Cracked or broken parts, and
- Any other condition that may affect its safe operation.

2. After every operation, use a vacuum to remove dust and chips from the tool and work area. Wipe the tool clean with a soft cloth. Make sure water does not get into the tool.

CAUTION: Most plastics are susceptible to damage from various types of commercial solvents. Do not use any solvents or cleaning products that could damage the plastic parts. Some of these include but are not limited to: gasoline, carbon tetrachloride, chlorinated cleaning solvents, and household detergents that contain ammonia.

3. Keep the ventilation openings free from dust and debris to prevent the motor from overheating.

4. Store the tool in a clean and dry place away from the reach of children.

CARBON BRUSH REPLACEMENT

The wear on the carbon brushes depends on how frequently and how heavily the tool is used. If you see excessive sparks during operation or if the tool stops working, inspect the brushes and replace them.

Replacement carbon brushes (Part No. 94396-029) can be purchased from wenproducts.com. Only genuine WEN replacement brushes designed specifically for your tool should be used.

1. To inspect the brushes, open the carbon brush covers (Fig. 4 - 1) by turning them counterclockwise with a flat-head screwdriver (not included).

2. Take out and inspect the carbon brushes (Fig. 5). If the brushes are worn to under 1/8 inch in length, replace them with new carbon brushes. Both carbon brushes should be replaced at the same time.

3. Reinstall the brush caps.

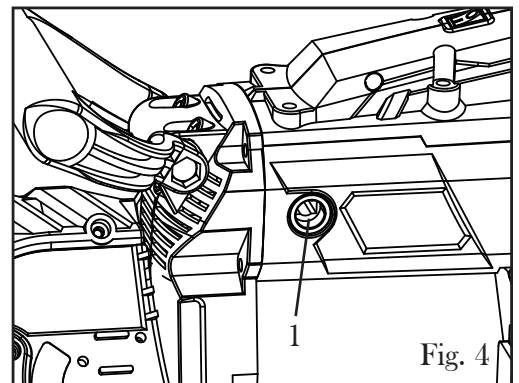

Fig. 4

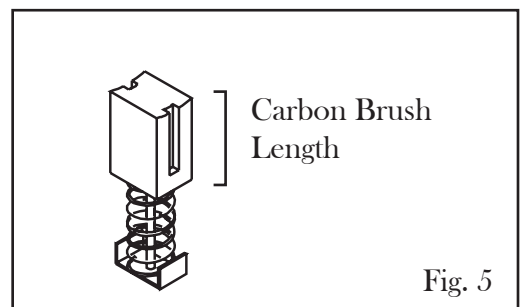

Fig. 5

PRODUCT DISPOSAL

Used power tools should not be disposed of together with household waste. This product contains electronic components that should be recycled. Please take this product to your local recycling facility for responsible disposal and to minimize its environmental impact.

TROUBLESHOOTING



WARNING: Stop using the tool immediately if any of the following problems occur. Repairs and re-placements should only be performed by an authorized technician. For any questions, please contact our customer service at (800) 232-1195, M-F 8-5 CST or email us at techsupport@wenproducts.com.

PROBLEM	POSSIBLE CAUSE	SOLUTION
Motor will not start	<ol style="list-style-type: none"> 1. Power cord or extension cord damaged or power plug not properly plugged in 2. No power at outlet 3. Defective power switch, defective motor, short circuit in motor or loose connections 4. Carbon brushes not properly installed. 	<ol style="list-style-type: none"> 1. Check the power cord, extension cord, power plug and the power outlet. Do not use if any part is damaged. 2. Check power at outlet. If outlet is unpowered, turn off tool and check the power supply's circuit breaker. If breaker is tripped, make sure circuit is right capacity for tool and circuit has no other loads. 3. Stop using the tool and contact customer service at (800) 232-1195, M-F 8-5 CST for assistance. 4. Remove and re-install the carbon brushes. Replacement carbon brushes if necessary.
Reduced performance	<ol style="list-style-type: none"> 1. Carbon brushes worn or damaged 2. Blade dull or damaged 	<ol style="list-style-type: none"> 1. Replace the carbon brushes (94396-029). 2. Replace with new saw blade (94396B).
Excessive noise or rattling	Internal damage or wear (e.g. carbon brushes or bearings)	Contact customer service at (800) 232-1195, M-F 8-5 CST for assistance.
Band saw over-heating	<ol style="list-style-type: none"> 1. Blade speed too fast 2. Too much pressure, motor overloaded 3. Blade dull or damaged 4. Motor housing vents are blocked 5. Extension cord too long or with an insufficient gauge 	<ol style="list-style-type: none"> 1. Reduce the speed. 2. Reduce pressure on the workpiece. Let the tool do the work. 3. Replace with new, sharp blade. 4. Wear ANSI-approved safety goggles and NIOSH-approved dust mask/respirator while blowing dust out of motor using compressed air. 5. Use an extension cord of appropriate gauge and length or plug tool directly into the outlet.

EXPLODED VIEW & PARTS LIST

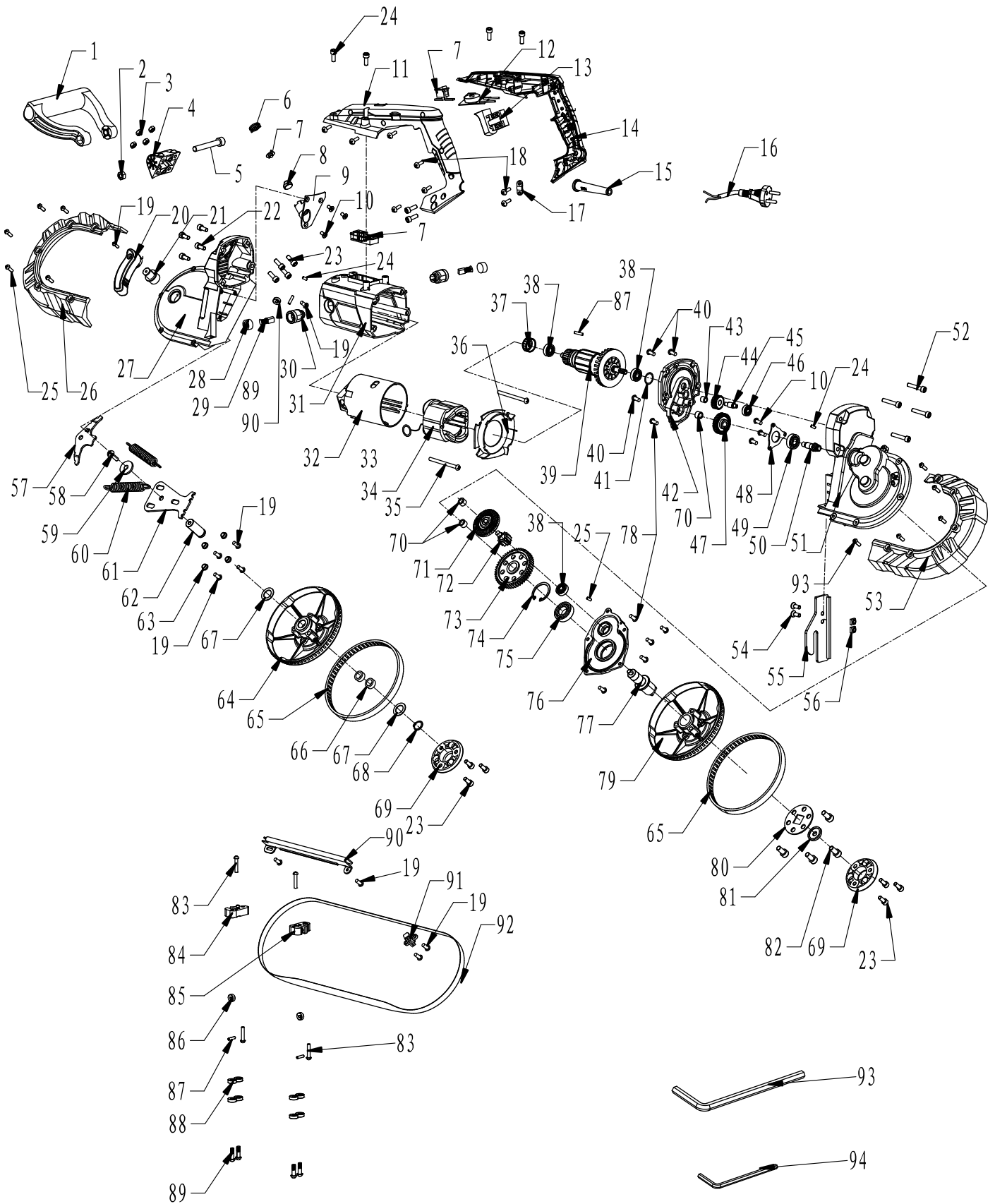

NOTE: Replacement parts can be purchased from wenproducts.com, or by calling our customer service at (800) 232-1195, M-F 8-5 CST. Parts and accessories that wear down over the course of normal use (e.g. saw blades, carbon brushes, etc.) are not covered by the two-year warranty.

EXPLODED VIEW & PARTS LIST

No.	Part No.	Description	Qty.
1	94396-001	Front Handle	1
2	94396-002	Nut M8	1
3	94396-003	Locking Nut	4
4	94396-004	Handle Base	1
5	94396-005	Screw M8×70	1
6	94396-006	Light Back Cover	1
7	94396-007	LED Light	1
8	94396-008	LED Cover	1
9	94396-009	Light Base	1
10	94396-010	Screw M4×8	6
11	94396-011	Left Handle	1
12	94396-012	Speed Controller	1
13	94396-013	Switch	1
14	94396-014	Right Handle	1
15	94396-015	Cord Sleeve	1
16	94396-016	Power Cord	1
17	94396-017	Cord Plate	8
18	94396-018	Screw M4×16	10
19	94396-019	Screw M4×12	1
20	94396-020	Tension Lever	1
21	94396-021	Tension Shaft	4
22	94396-022	Screw M6×20	16
23	94396-023	Screw M6×14	3
24	94396-024	Pin 4×10	10
25	94396-025	Screw M5×12	1
26	94396-026	Front Blade Guard	1
27	94396-027	Front Cover	2
28	94396-028	Brush Cap	2
29	94396-029	Carbon Brush	2
30	94396-030	Brush Holder	1
31	94396-031	Housing	1
32	94396-032	Stator Sleeve	2
33	94396-033	Tension Spring	1
34	94396-034	Stator	2
35	94396-035	Screw 4.8×55	1
36	94396-036	Dust-Proof Ring	1
37	94396-037	Bearing Sleeve	3
38	94396-038	Bearing 608Z	1
39	94396-039	Rotor	3
40	94396-040	Screw M5×10	1
41	94396-041	O Ring 25×22×1.5	1
42	94396-042	Middle Cover	1
43	94396-043	Bearing HK0608	1
44	94396-044	Pinion	1
45	94396-045	Pinion Shaft	1
46	94396-046	Bearing 626	1
47	94396-047	Driving Gear	1

No.	Part No.	Description	Qty.
48	94396-048	Bearing Press Sleeve	1
49	94396-049	Bearing 6000Z2RS	1
50	94396-050	Intermediate Gear Shaft	1
51	94396-051	Gear Box	4
52	94396-052	Screw M6×40	1
53	94396-053	Rear Blade Guard	2
54	94396-054	Screw M6×16	1
55	94396-055	Guide Bar	2
56	94396-056	Screw Nut M6	1
57	94396-057	Adjusting Support	1
58	94396-058	Screw M6×20	1
59	94396-059	Tension Wheel	2
60	94396-060	Extension Spring	1
61	94396-061	Movable Support	1
62	94396-062	Driving Shaft	4
63	94396-063	Locating Sleeve	1
64	94396-064	Driven Wheel	2
65	94396-065	Non-Slip Band	2
66	94396-066	Bushing	2
67	94396-067	Dust-Proof Washer	1
68	94396-068	Circlip Φ16	2
69	94396-069	Driven Wheel Cover	3
70	94396-070	Bearing HK0808	1
71	94396-071	Gear	1
72	94396-072	Driven Gear Shaft	1
73	94396-073	Driven Gear	1
74	94396-074	Collar Φ35	1
75	94396-075	Bearing 6003Z22RS	1
76	94396-076	Gear Box Cover	1
77	94396-077	Output Shaft	6
78	94396-078	Screw M5×14	1
79	94396-079	Driving Wheel	1
80	94396-080	Coupler	1
81	94396-081	Press Plate	4
82	94396-082	Screw M8×14	4
83	94396-083	Screw M5×25	1
84	94396-084	Bearing Guide Block 2	1
85	94396-085	Bearing Guide Block 1	3
86	94396-086	Bearing 624	4
87	94396-087	Pin 4×16	8
88	94396-088	Bearing 696	4
89	94396-089	Bearing Mounting Screw	1
90	94396-090	Blade Holder	1
91	94396-091	Brush	1
92	94396B	Blade	1
93	94396-093	Hex Wrench, M6	1
94	94396-094	Hex Wrench, M4	1

LIMITED TWO YEAR WARRANTY

WEN Products is committed to build tools that are dependable for years. Our warranties are consistent with this commitment and our dedication to quality.

LIMITED WARRANTY OF WEN CONSUMER POWER TOOLS PRODUCTS FOR HOME USE

GREAT LAKES TECHNOLOGIES, LLC (“Seller”) warrants to the original purchaser only, that all WEN consumer power tools will be free from defects in material or workmanship for a period of two (2) years from date of purchase. Ninety days for all WEN products, if the tool is used for professional use.

Seller’s sole obligation and your exclusive remedy under this Limited Warranty and, to the extent permitted by law, any warranty or condition implied by law, shall be the repair or replacement of parts, without charge, which are defective in material or workmanship and which have not been misused, carelessly handled, or misrepaired by persons other than Seller or Authorized Service Center. To make a claim under this Limited Warranty, you must make sure to keep a copy of your proof of purchase that clearly defines the Date of Purchase (month and year) and the Place of Purchase. Place of purchase must be a direct vendor of Great Lakes Technologies, LLC. Third party vendors such as garage sales, pawn shops, resale shops, or any other secondhand merchant void the warranty included with this product. Contact techsupport@wenproducts.com or 1-800-232-1195 to make arrangements for repairs and transportation.

When returning a product for warranty service, the shipping charges must be prepaid by the purchaser. The product must be shipped in its original container (or an equivalent), properly packed to withstand the hazards of shipment. The product must be fully insured with a copy of the warranty card and/or the proof of purchase enclosed. There must also be a description of the problem in order to help our repairs department diagnose and fix the issue. Repairs will be made and the product will be returned and shipped back to the purchaser at no charge.

This limited warranty does not apply to accessory items that wear out from regular usage over time including belts, brushes, blades, etc.

Any implied warranties shall be limited in duration to two (2) years from date of purchase. Some states in the U.S., Some Canadian provinces do not allow limitations on how long an implied warranty lasts, so the above limitation may not apply to you.

In no event shall seller be liable for any incidental or consequential damages (including but not limited to liability for loss of profits) arising from the sale or use of this product. Some states in the U.S. And some Canadian provinces do not allow the exclusion or limitation of incidental or consequential damages, so the above limitation or exclusion may not apply to you.

This limited warranty gives you specific legal rights, and you may also have other rights which vary from state to state in the U.S., province to province in Canada and from country to country.

This limited warranty applies only to portable electric tools, bench power tools, outdoor power equipment and pneumatic tools sold within the united states of America, Canada and the commonwealth of Puerto Rico. For warranty coverage within other countries, contact the WEN customer support line.

THANKS FOR REMEMBERING 