

- 418 Oiler
- 1 Gallon Nu-Clear Thread Cutting Oil
- 32 Transporter

Catalog No.	Model No.	Description	Spindle Speed RPM	Weight	
				Lb.	Kg.
41855	300 Only	115V,25-60 Hz	38	94	43.0
75075	300 Only	115V,25-60 Hz	57	94	43.0
41860	300 Only	230V,25-60 Hz	38	94	43.0
75435	300 Only	230V,25-60 Hz	38	94	43.0
15682	300 Complete	115V,25-60 Hz 1/2" – 2" NPT	38	212	96.2
15722	300 Complete	115V,25-60 Hz 1/2" – 2" NPT	57	212	96.2

Machine Assembly

⚠ WARNING



To prevent serious injury, proper assembly of the Power Drive is required. Failure to mount the Power Drive to a stable stand or bench may result in tipping and serious injury. The following procedures should be followed:

Mounting on No. 1206 Stand

1. Set up the 1206 Stand by opening legs and pushing down on the tray. Legs should be stiff and the stand should not wobble.

NOTE! The trisland leg stiffness can be increased or decreased by the following procedure:

- Place stand upside down on a flat surface.
- Unlock tray so legs are loose.
- Locate the set screw on the tray leg support on the rear leg (*Figure 3*).
- Loosen the set screw to make the adjustment. To increase stiffness, move the tray leg support up towards the base. To decrease stiffness, move the tray leg down towards the feet.
- Tighten the set screw (increasing leg stiffness increases tray tension).

2. Mount power drive on the stand using bolts and wing nuts (*Figure 3*).

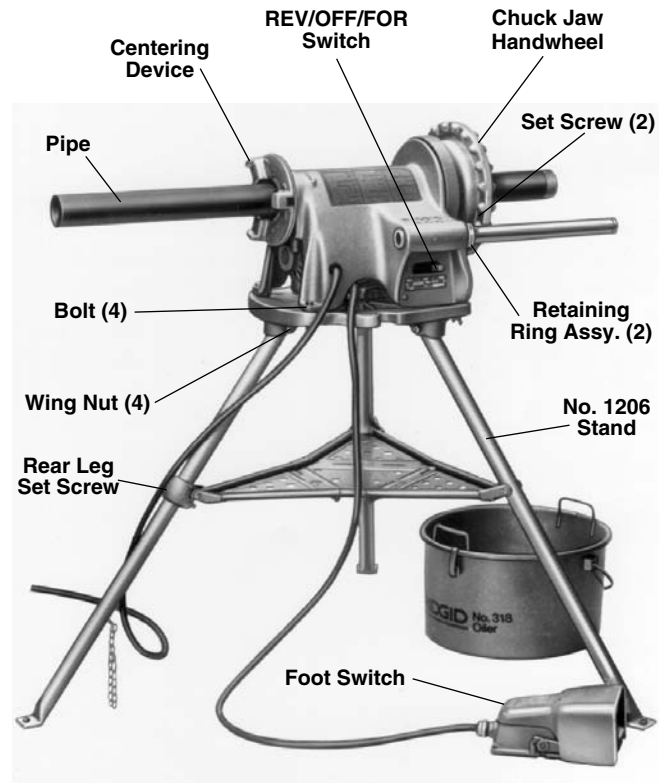

Figure 3 – 300 Power Drive Mounted on No. 1206 Stand with 418 Oiler

Mounting 311A Carriage and Tools

1. Inspect the support bars to insure they are forward and secured by two (2) retaining ring assemblies. Retaining ring set screws must be tight (*Figure 4*).

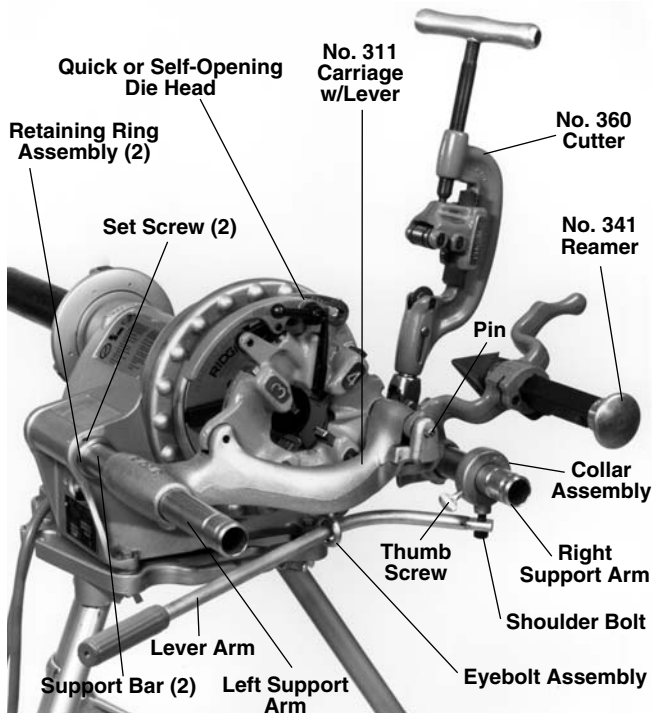

Figure 4 – No. 300 Power Drive with 311A Carriage, 360 Cutter, 341 Reamer and Die Head

2. Secure eyebolt to the 311A Carriage. Slide lever arm through the eyebolt assembly and secure to collar assembly with shoulder bolt (Figure 4).
3. Tighten collar assembly thumb screw into groove on support bar.
4. Install the 360 Cutter and 341 Reamer by inserting arm in the slot provided in the carriage and secure with the drive pin (Figure 4).
5. Install 811A Die Head by inserting die head post into the mating hole in the carriage.

NOTE! When fully inserted, spring-loaded ball will hold die head in place.

Machine Inspection

⚠ WARNING



To prevent serious injury, inspect your Power Drive. The following inspection procedures should be performed on a daily basis:

1. Make sure Power Drive is unplugged and the directional switch is set to the OFF position (Figure 3).
2. Clean the speed chuck jaws with a wire brush.
3. Inspect the jaw inserts for excessive wear. Refer to the Maintenance Instructions if they need to be replaced.

NOTE! For plastic and coated work pieces, special jaw inserts (Part No. 97365) should be used to prevent damaging the workpiece.

4. Make sure the foot switch is present and attached to the Power Drive (Figure 3).

⚠ WARNING Do not operate the Power Drive without a foot switch.

5. Inspect the power cord and plug for damage. If the plug has been modified, is missing the grounding pin or if the cord is damaged, do not use the Power Drive until the cord has been replaced.
6. Inspect the Power Drive for any broken, missing, misaligned or binding parts as well as any other conditions which may affect the safe and normal operation of the machine. If any of these conditions are present, do not use the Power Drive until any problem has been repaired.
7. Lubricate the Power Drive spindle bearings if necessary according to the Maintenance Instructions.
8. Use tools and accessories that are specifically designed for your Power Drive and meet the needs of your application. The correct tools and accessories allow you to do the job successfully and safely. Accessories suitable for use with other equipment may be hazardous when used with this Power Drive.
9. Clean any oil, grease or dirt from all handles and controls. This reduces the risk of injury due to a tool or control slipping from your grip.

Inspect the cutting edges of your tools and dies. If necessary, have them replaced prior to using the Power Drive. Dull or damaged cutting tools and dies can lead to binding, tool breakage and poor quality threads.

10. Clean metal shavings and other debris from the chip tray of the 418 Oiler. Check the level and quality of the thread cutting oil. Replace or add oil if necessary.

NOTE! Thread cutting oil lubricates and cools the threads during the threading operation. A dirty or poor grade cutting oil can result in poor thread quality.

Machine and Work Area Set-Up

⚠ WARNING

To prevent serious injury, proper set-up of the machine and work area is required. The following procedures should be followed to set-up the machine:

1. Locate a work area that has the following:
 - Adequate lighting.
 - No flammable liquids, vapors or dust that may ignite.
 - Grounded electrical outlet.
 - Clear path to the electrical outlet that does not contain any sources of heat or oil, sharp edges or moving parts that may damage electrical cord.
 - Dry place for machine and operator. Do not use the machine while standing in water.
 - Level ground.
2. Clean up the work area prior to setting up any equipment. Always wipe up any oil that may have splashed or dripped from the machine or oiler to prevent slips and falls.
3. Set up the Power Drive on a flat, level surface.
 - For a Power Drive mounted on a 1206 Stand, open legs of stand and push down on the tray. Legs should be stiff and stand should not wobble.

NOTE! To increase or decrease leg stiffness, refer to instructions on “Mounting On 1206 Stand”.

4. If the workpiece extends more than four (4) feet beyond the Power Drive, use one or more pipe stands to prevent tipping and the oscillation of the pipe.
5. If the workpiece extends beyond the Power Drive, set-up guards or barricades to create a minimum of three (3) feet of clearance around the Power Drive and workpiece. This “safety zone” prevents others from accidentally contacting the machine or workpiece and either causing the equipment to tip or becoming entangled in the rotating parts.
6. If necessary, fill the 418 Oiler with RIDGID Thread Cutting Oil. Position the oiler under the front of the Power Drive (*Figure 3*).
7. Make sure FOR/OFF/REV switch is in the OFF position.
8. Position the foot switch so that the operator can safely control the machine, tools and workpiece. As shown in *Figure 8*, it should allow the operator to do the following:

- Stand facing the directional switch.
- Use the foot switch with his left foot.
- Have convenient access to the directional switch, tools and chucks without reaching across the machine.

Machine is designed for one person operation.

9. Plug the Power Drive into the electrical outlet making sure to position the power cord along the clear path selected earlier. If the power cord does not reach the outlet, use an extension cord in good condition.

⚠ WARNING

To avoid electrical shock and electrical fires, never use an extension cord that is damaged or does not meet the following requirements:

- The cord has a three-prong plug similar to shown in Electrical Safety section.
- The cord is rated as “W” or “W-A” if being used outdoors.
- The cord has sufficient wire thickness (14 AWG below 25’/12 AWG 25’ - 50’). If the wire thickness is too small, the cord may overheat, melting the cord’s insulation or causing nearby objects to ignite.

⚠ WARNING To reduce risk of electrical shock, keep all electrical connections dry and off the ground. Do not touch plug with wet hands.

10. Check the Power Drive to insure it is operating properly.
 - Flip the directional switch to FOR (Forward). Press and release the foot switch. Check that the Power Drive rotates in a counterclockwise direction as you are facing the front chuck. Have the Power Drive serviced if it rotates in the wrong direction or if the foot switch does not control its stopping or starting.
 - Depress and hold the foot switch. Inspect the moving parts for misalignment, binding, odd noises or any other unusual conditions that may affect the safe and normal operation of the machine. If such conditions are present, have the power drive serviced.
 - Flip the directional switch to REV (Reverse). Press and release the foot switch. Check that the Power Drive rotates in a clockwise direction as you are facing the chuck.
 - Release the foot switch and flip the directional switch to OFF.