

STANLEY®



ST3TWPLT-(CA)
WHEEL KIT
INCLUDED



ST2STWPLT-(CA)
PRE-DRILLED & TAPPED FOR
OPTIONAL WHEEL KIT:
PART #STWKT



ST4TWPLT-(CA)
WHEEL KIT
INCLUDED

TRASH WATER PUMP **INSTRUCTION MANUAL**

PLEASE READ THIS MANUAL CAREFULLY
BEFORE OPERATING YOUR NEW WATER PUMP
(CA) in the Model Number designates California Compliant by CARB
1/12/2015

STANLEY®



**DO NOT RETURN
THIS PRODUCT TO THE STORE**

WE ARE HERE FOR YOU!

Call Customer Service Toll-Free 1-877-684-8912
or visit us online at www.lifanpowerusa.com

**NO DEVUELVA ESTE
PRODUCTO A LA TIENDA**

ESTAMOS AQUÍ PARA USTED!

Llame a nuestro equipo de Servicio al Cliente Línea Gratis 1-877-684-8912
o visite nuestra página en el internet www.lifanpowerusa.com

**NE PAS RETOURNER
CE PRODUIT AU MAGASIN**

NOUS SOMMES ICI POUR VOUS!

Communiquer avec Notre Équipe de Service à la Clientèle sans Frais au
ou en ligne à www.lifanpowerusa.com

Instruction Manual

**PLEASE READ THIS MANUAL
CAREFULLY BEFORE OPERATING
YOUR NEW
STANLEY® Water Pump
AND SAVE THESE INSTRUCTIONS**

This Manual is for the following Models

ST2STWPLT-(CA), ST3TWPLT-(CA) & ST4TWPLT-(CA)

STANLEY® Water Pumps are compliant for sale and use
in all 50 States and Canada

CA Indicates the unit is certified for sale in California

PLEASE READ THE FOLLOWING INSTRUCTIONS!

1. Unit shipped with "NO OIL" in engine or where applicable, pumps and/or accessories. Check and fill with proper oil as outlined in the Owner's Manual for the respective product.
2. For repair under Warranty or questions concerning Warranty, DO NOT return this product to the store where purchased. Follow the procedures as outlined in the "WARRANTY POLICY" and "WARRANTY REGISTRATION" in the Owner's Manual. For any questions please call your Customer Service Hotline at 1-877-684-8912.
3. Read the "Owner's Manual" prior to operating any equipment and familiarize yourself with the proper and safe operation of the equipment. If you have any questions please call the Customer Service Hotline at 1-877-684-8912.

This Owner's Manual is for the Following Models:



ST2STWPLT-(CA)

Pre-Drilled & Tapped for Optional
Wheel Kit: Part #STWKT



ST3TWPLT-(CA)

Wheel Kit Included



ST4TWPLT-(CA)

Wheel Kit Included

(ST) indicates this unit is a STANLEY® product.
(STWP) indicates this unit is a Semi-Trash Water Pump
(TWP) indicates this unit is a Full Trash Water Pump
(-CA) indicates this unit is CARB Certified for California

Table of Contents

Preface	4
Product Specifications	5
Safety Instructions	6
Controls and Features	11
PRE-OPERATING INSTRUCTIONS	12
Connecting Water Inlet Hose	12
Connecting Water Outlet Hose	13
Engine Oil Level Check	14
Engine Fuel Level Check	15
Air Cleaner Element Check	16
Pump Water Capacity Check	17
Operation of Water Pump	18
Transporting and Storing the Unit	21
Maintenance	22
Troubleshooting	26
Water Pump Safety	27
Limited Warranty Policy	28

Preface

Thank you for choosing STANLEY® for your Water Pump Needs. STANLEY® prides itself on providing quality products at affordable pricing, creating the “Best Equipment Value on Today’s Market!”

All STANLEY® Water Pump products are manufactured with quality components. Your new Water Pump will give you years of dependable service. Your STANLEY® Water Pump is designed, engineered, and manufactured with LIFAN’s Industrial Grade Gasoline Engine. This Owner’s Manual will provide you with all of your needed information for your new Power Equipment Product, including Safe Operation and Maintenance of your unit. Please read this Owner’s Manual completely and carefully prior to operation. Keep this Owner’s Manual for assistance in the future, such as proper maintenance schedules and tips to prolong the life and effective use of your unit. We want to help you get the best results from your new unit while operating this equipment safely. If you require assistance, please call the Customer Service Hotline at 1-877-684-8912.

This Owner’s Manual contains information with respect to the newest products at the time of publication. Due to revision and modifications, the information noted in the Owner’s Manual might vary from the actual status. This Owner’s Manual is subject to change without notice. The copyright of the Owner’s Manual belongs to STANLEY®. Any group or individual is forbidden to reprint or copy any of this Owner’s Manual without the written consent of STANLEY®.

FOR ALL WARRANTY AND SERVICE RELATED ISSUES/QUESTIONS DO NOT RETURN YOUR UNIT TO THE STORE OR DEALER WHERE THE ITEM WAS PURCHASED. FOR SERVICE PLEASE CALL THE STANLEY® CUSTOMER SERVICE HOTLINE AT 1-877-684-8912. WE WILL BE HAPPY TO HANDLE YOUR WARRANTY ISSUE OR DIRECT YOU TO THE NEAREST “AUTHORIZED SERVICE CENTER.”

Product Specifications

Model	ST2STWPLT-CA	ST3TWPLT-CA	ST4TWPLT-CA
Suction/Discharge	2 in	3 in	4 in
Rotation Velocity	3600rpm	3600rpm	3600rpm
Delivery	9,510 gph	17,440 gph	25,500 gph
Suction Lift	26 ft	26 ft	26 ft
Maximum Pump Head	85 ft	98 ft	98 ft

Manufacturer	LIFAN	LIFAN	LIFAN
Engine	LF170F-P	LF188F-P	LF190F-P
Type	OHV Industrial	OHV Industrial	OHV Industrial
Maximum Horsepower	7HP	13HP	15HP
Displacement	212cc	288cc	420cc
Starting System	Recoil	Recoil	Recoil
Fuel Tank Capacity	2.5 Gallons	4 Gallons	4 Gallons
Run Time	8 hrs	8 hrs	8 hrs
Fuel Type	87 Octane Gasoline	87 Octane Gasoline	87 Octane Gasoline
Oil Amount	SAE 10w30w20oz	SAE 10w30w32oz	SAE 10w30w32oz
Low Oil Shutoff	Yes	Yes	Yes
CARB Certified	Yes	Yes	Yes
Length	27 in (68.58cm)	33 ½ (85.09cm)	33 ½ (85.09cm)
Width	22 in (55.88cm)	24 ½ in (62.23cm)	24 ½ in (62.23cm)
Height	21 in (53.34cm)	25 in (63.5cm)	25 in (63.5cm)
Dry Weight	79 lbs	152 lbs	154 lbs
Comments MHPa = Maximum Horsepower gph = gallons per hour L/hr = Liters per hour			

Safety Instructions



This is the safety alert symbol. It is used to alert you to potential personal injury hazards. Obey all safety messages that follow this symbol to avoid possible injury or death.

To reduce the risk of injury, user must read all safety, pre-operating and operating instructions before using the product.

Definitions: This instruction manual uses the following safety alerts, signal words and symbols to alert you to certain hazards and the related risk of injury:

DANGER indicates a hazard that, if not avoided, will result in death or serious injury.

CAUTION indicates a hazard that, if not avoided, may result in minor or moderate injury.

WARNING indicates a hazard that, if not avoided, may result in death or serious injury.

NOTICE indicates a condition not related to personal injury that, if not avoided, may result in property damage.

Hazard Symbols and Meanings

Toxic Fumes



Hot surface or gas



Explosion



Fire



Electrical Shock



WARNING!

To reduce the risk of injury, operator must read instruction manual before operating product.



DANGER!

Running water pump emits carbon monoxide: an odorless, colorless, poison gas. Breathing carbon monoxide can cause serious injury or death!

ONLY operate water pump outdoors.

Exhaust gas must be prevented from entering confined areas.

Direct exhaust gas away from windows, doors, ventilation and other openings.

Do not operate water pump inside or under any buildings.



WARNING!

This product and its exhaust contain chemicals known to the State of California to cause cancer and birth defects or other reproductive harm. Wash hands after handling.

Safety Instructions (continued)



WARNING!

Rapid recoil of starter cord (kickback) may pull hand and arm forward toward engine at a rapid rate. Broken bones, bruises, sprains, and fractures may result.

When starting engine, pull cord slowly until tension is felt, then pull rapidly to avoid kickback

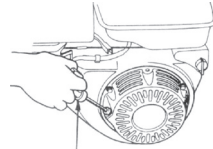

起动手柄



WARNING!

Fuel and its vapors are extremely flammable and explosive.



Fire or explosion can cause severe burns or death.



WHEN ADDING OR DRAINING FUEL

- Turn water pump off and let it cool for at least three minutes before removing fuel cap. Loosen cap slowly in order to relieve pressure in the fuel tank.
- Fill or drain fuel tank outdoors. Do not excessively inhale fuel vapors.
- Keep away from open flames or sparks and other sources of ignition.
- Do NOT smoke while filling fuel tank.
- Do NOT overfill tank. Allow space for fuel expansion.

WHEN TRANSPORTING OR REPAIRING EQUIPMENT

- Transport water pump with the fuel valve in the off position.
- Repair water pump with the fuel tank empty or the fuel valve in the off position.
- Disconnect spark plug wire before transport or service.

WHEN STORING FUEL OR EQUIPMENT CONTAINING FUEL

- Store away from furnaces, stoves, water heaters, clothes dryers or other appliances that have pilot light or other ignition source because they can ignite fuel vapors.

WHEN STARTING EQUIPMENT

- Ensure spark plug, muffler, air cleaner, and fuel cap are in place.
- Do NOT crank engine with spark plug removed.
- If fuels spills, wait until it evaporates before starting engine.

WHEN OPERATING EQUIPMENT

- Do not choke carburetor to stop engine.
- Do not tip engine or equipment at an angle, which causes fuel to spill.

Safety Instructions (continued)



WARNING!



While engine is running temperature may exceed 150°F (65°C). Severe burns may occur.



Exhaust heat/gasses can ignite combustibles, structures or damage fuel tank causing a fire.

- Do NOT touch hot surfaces and do avoid exhaust gasses.
- Allow water pump to cool before touching.
- Keep at least 6 ft. (183cm) clearance on all sides of water pump including overhead clear.
- Reflective exhaust heat may damage fuel tank causing fire.
- Code of Federal Regulation(CFR) Title 36 Parks, Forests, and Public Property require equipment powered by an internal combustion engine to have a spark arrester, maintained in working order, complying to USDA Forest service standard 5100-1c or later revision. In the state of California a spark arrester is required under section 4442 of the California Public resources code.



WARNING!



Unintentional sparking can result in fire or electrical shock.

WHEN TESTING FOR ENGINE SPARK

- Do NOT check for spark with the spark plug removed.
- Use approved spark plug tester.

WHEN REPAIRING OR ADJUSTING WATER PUMP

- Disconnect the spark plug wire from the spark plug and place the wire where it cannot contact spark plug.

NOTICE!

Improper use and care of this water pump will cause damage and shorten its lifespan. Failure to follow these instructions will void all warranties.

- Do NOT operate your power equipment in inclement weather such as rain, snow and/or sleet.
- Never allow children or animals to be near this equipment during operation. Only qualified persons should operate this equipment. Please follow all guidelines contained in this owner's manual for the safe operation of this equipment.

NOTE: Pumping of inflammable or corrosive liquids such as gasoline, seawater, chemical solutions, alkaline liquids or acids is forbidden with any unit EXCEPT ST2CCWPLT-CA, Chemical Corrosive Liquids Pump designed for this purpose!

Controls and Features

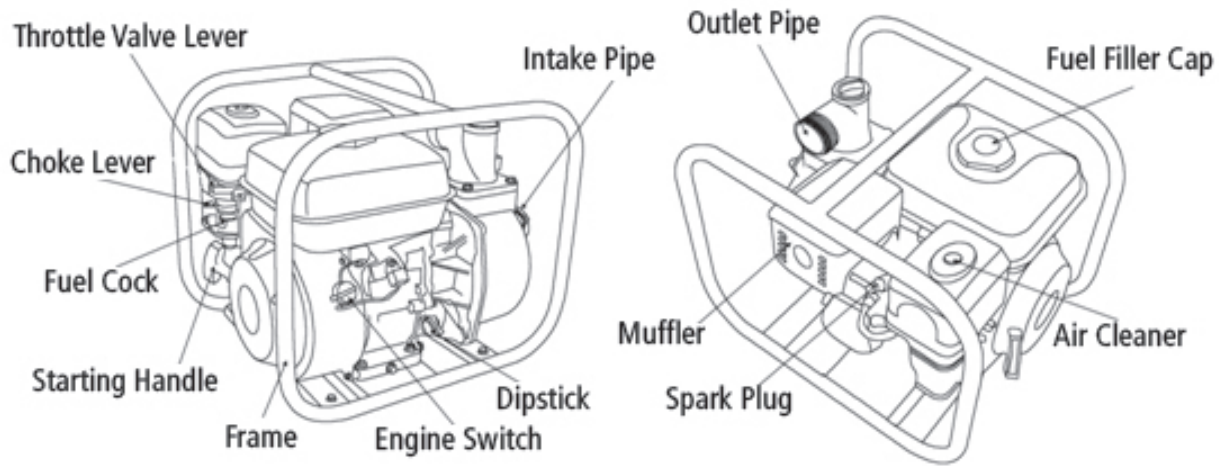

LEGEND

Throttle Valve Lever	Controls engine speed.
Choke Lever	Before starting cold engine, rotate the choke lever to the left until resistance is felt. After starting the water pump, rotate the choke lever to the right to disengage. Do NOT choke a warm engine when starting.
Fuel Cock	Turn to "OFF" position to terminate fuel delivery to engine.
Recoil Starting Handle	Pull handle to rotate engine for starting.
Frame	1" round steel tubing for maximum protection.
Engine Switch	Rocker Style: Set to "ON" position to start engine & "OFF" position to shut engine off.
Dipstick	Check/fill engine oil.
Intake Pipe	Pump section intake.
Outlet Pump	Pump discharge pipe.
Muffler	Oversized for quiet operation.
Spark Plug	Engine spark plug location. Check maintenance schedule for service intervals. Disengage during transportation and storage. NEVER start engine with spark plug disengaged
Air Cleaner	Check maintenance schedule for service intervals
Fuel Filler Cap	Vented fuel cap must be properly installed at all times during operation.

Pre-Operating Instructions: Connecting Water Inlet Hose

Use commercially available hose, hose joint, and clamp. The water inlet hose must be of continuous structure and be rigid. The length of the hose should be no more than required. The effect of suction is greatest at shorter distances from the water surface. Suction time varies with the length of the water inlet hose. The strainer matching with the water pump should be mounted to the end of the water inlet hose with a hose clamp.

NOTE: The ST1WP-CA, 1" inlet/outlet is threaded with American Garden Hose threads to accept your 3/4" garden hose to use as the suction and discharge hoses eliminating the necessity to purchase an additional hose kit for your pump.

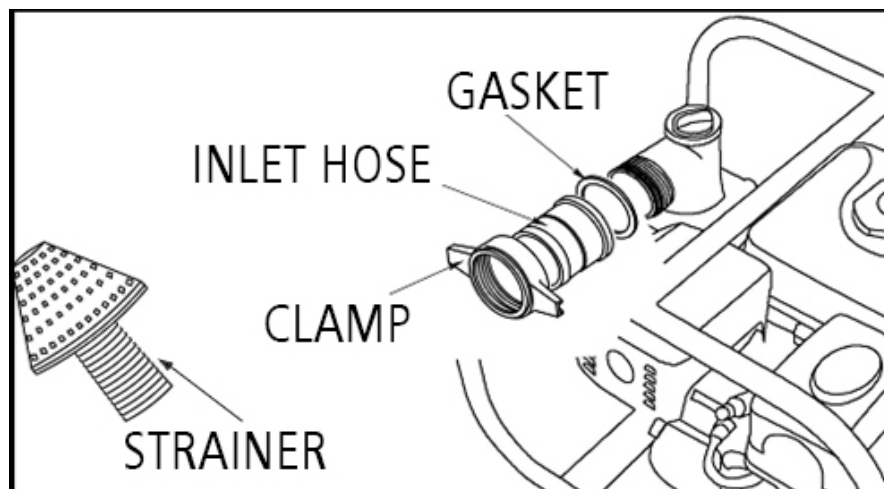

NOTICE:

- Before pumping, install the strainer securely to the end of the water inlet hose. This strainer will filtrate any impurity, which may produce a passage jam and damage impellers.
- Be sure to install the hose joint and clamp properly and tightly to prevent air leaks and pumping performance drops. A loose water inlet hose will decrease the water pump performance and self-suction ability.

Pre-Operating Instructions: Connecting Water Outlet Hose

Use commercially available hose, hose joint, and clamp. A short hose with a big diameter will provide the best performance. A long hose with a small diameter will increase flowing resistance and decrease the power output of the water pump.

Always Use Commercial Grade and Proper Size Hoses for Your Pump

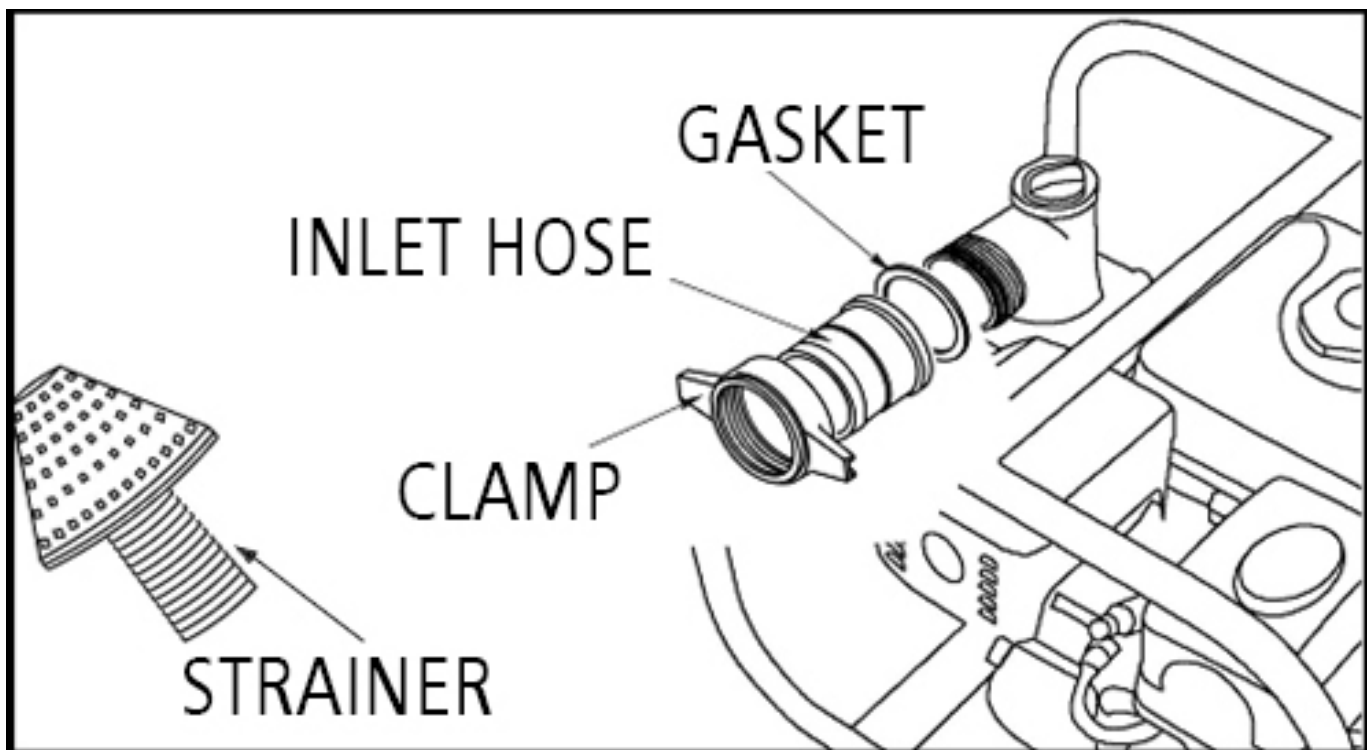

NOTE: Tighten the hose clamp to keep from disengaging during operation under high pressure.

Pre-Operating Instructions: Engine Oil Level Check

NOTICE:

- Running engine with insufficient engine oil can cause severe damage to the engine.
- The engine performance and service life is directly dependent of the quality of the engine oil. Do NOT use contaminated engine oil or vegetable oil
- Check engine oil level only with the engine stalled and with unit on level ground.
- Use 4-stroke gasoline engine oil equivalent in quality with SF, SG from API.

Oil viscosity varies with average environmental temperature. Select engine oil with proper viscosity using the chart below in accordance with your regional environmental temperature.

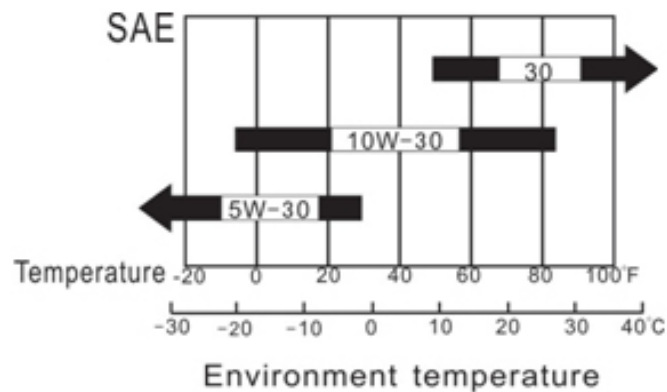

Engine Oil Alarm System

The engine oil alarm system aids in avoiding engine damage due to improper amounts of engine oil in the crankcase. Before the engine oil level in the crankcase drops below the safety line, the engine oil alarm system will automatically stall the engine (while the engine switch remains in the "ON" position).

If the engine stops and will not restart:

1. Remove the engine oil dipstick and wipe it clean.
2. Insert the dipstick into the engine oil filler hole without screwing it in.
3. Remove dipstick and check engine oil amount.
4. If engine oil is below required amount, fill specified engine oil up to the top of filler hole. Use engine oil depended on environmental temperature. Refer to Product Specification section for proper engine oil capacity.

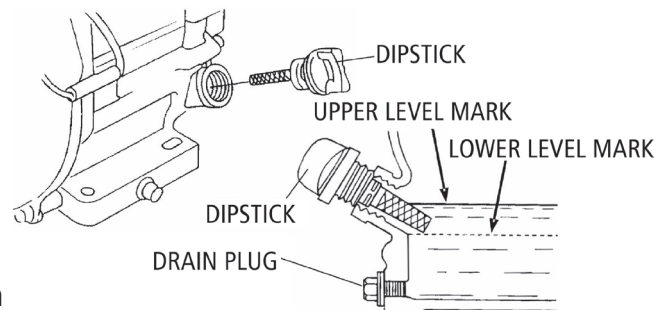

Pre-Operating Instructions: Engine Fuel Level Check



WARNING:

- Gasoline is extremely flammable. Keep away from ignition sources.
- Fuel unit only in well-ventilated areas with the engine stalled.
- Do NOT smoke near unit.
- Do NOT spill fuel out of the fuel tank. Spilled gasoline and gasoline vapor may ignite. If gasoline is spilled, wipe completely dry before starting the engine.
- Avoid repeated or sustained breathing of gasoline fumes.
- Avoid skin contact with gasoline.
- Keep out of reach of children and pets.
- Do NOT use contaminated gasoline. Keep dirt, dust and water out of fuel tank.
- After fueling is complete, ensure fuel filler cap is securely fastened.

To Check Engine Fuel Level:

1. Remove fuel filler cap.
2. Visually check fuel level within gas tank.
3. If too low, add fuel. Only use specified gasoline. Unleaded gasoline is recommended. Refer to Product Specification section for fuel tank capacity.

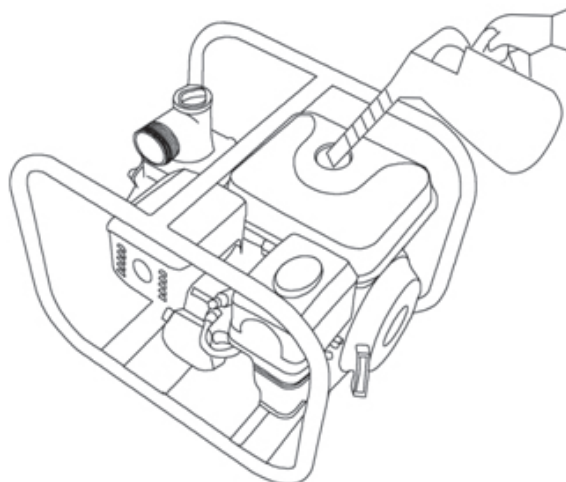

Pre-Operating Instructions: Air Cleaner Element Check

NOTICE:

- Do NOT run the engine without air cleaner element installed. Operation of engine without air cleaner element installed will result in the inhalation of dirt, dust and other debris into the engine and through the carburetor. This will result in premature wear of the engine.

NOTICE:

To Check Air Cleaner Element:

1. Remove the clip (item 9 in "Air Cleaner A" below) or the wing nut (item 7 in "Air Cleaner B" below) to remove and check the air filter element.
2. For sponge type air filters, wash with soap and water when contaminated. Squeeze excess liquid from air filter element and allow the air filter element to dry.
For paper type air filters, replace with the correct air filter for your unit. They are available at your dealer or from STANLEY®. Order your filter by calling toll free 1-877-684-8912.
3. Re-Install the air filter element into the air filter housing.

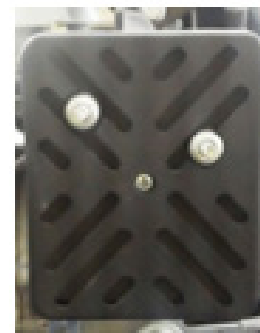
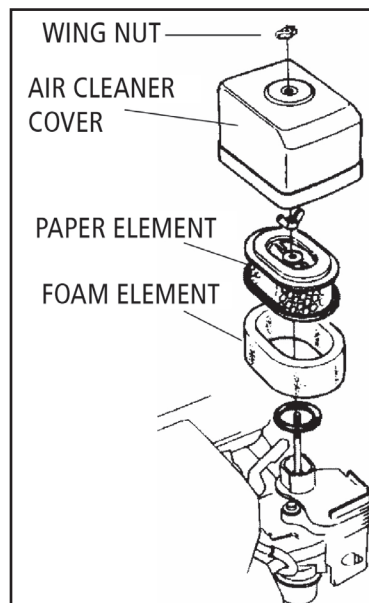

Pre-Operating Instructions: Air Cleaner Element Check

PRIME PUMP BEFORE USE!

NOTICE:

- Do NOT run engine without water inside the pump. Operation of engine without water inside the pump will cause the pump to overheat. Prolonged operation of engine without water inside the pump will damage the pump gasket and impeller.
- If water within the pump is not full, shut off the engine at once and fill the pump after allowing the unit to cool.

To Check Pump Water:

1. Remove water filler cap.
2. Visually check for water inside pump.
3. If too low, add water through water filler hole.
4. Securely re-fasten water filler cap.

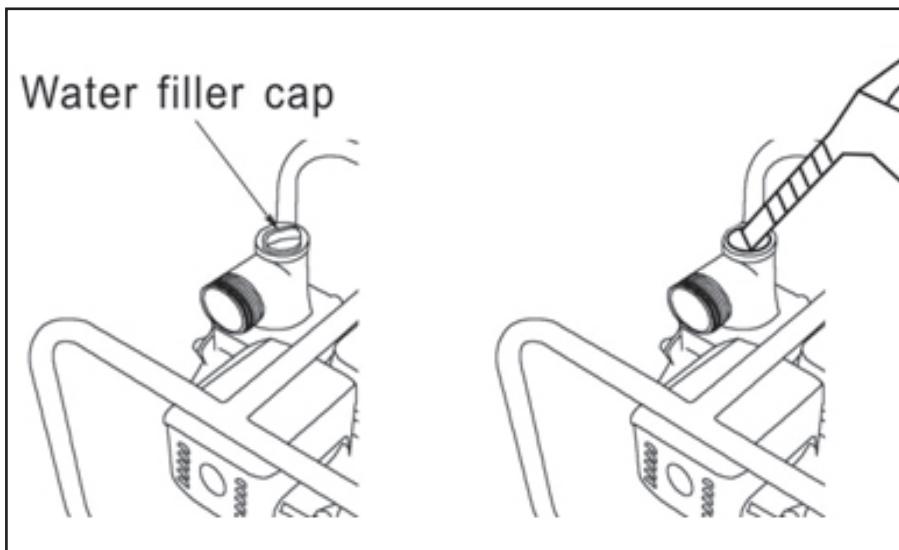

Operation of Water Pump

Water Pump Use Location:



DANGER!

Running water pump gives off carbon monoxide gas. It is odorless, colorless, and highly toxic. Breathing carbon monoxide gas will result in serious injury or death.

- Only operate water pump outdoors.
- Prevent exhaust gas from entering, through windows doors or ventilation intakes, any confined areas.
- DO NOT operate water pump inside any enclosed or roofed areas.

Before Operating Water Pump: Refer to Pre-Operating Instruction section for additional procedures and definitions.

1. Check water pump condition.
 - a. Inspect for signs of damage, oil or fuel leaks.
 - b. Remove excessive dirt and/or debris from the unit.
2. Check suction and discharge hoses.
 - a. Inspect general condition of hoses to ensure hoses are in serviceable condition.
 - i. Suction hose must be reinforced construction to prevent hose collapse.
 - b. Ensure sealing washer in suction hose connector is in operable condition.
 - c. Ensure hose connectors and clamps are securely installed.
 - d. Ensure filter is in operable condition and securely installed on suction hose.
3. Check the engine.
 - a. Ensure proper engine oil amount.
 - b. Ensure air cleaner element is clean and installed.
 - c. Ensure proper fuel level amount.
4. Ensure water pump is on a level surface.
5. Ensure engine switch is in the "OFF" position.
6. Ensure water pump is at least 3ft (1m) away from building walls and other equipment during operation. Do NOT place flammable objects close to water pump.
7. Never allow children to operate your pump. Keep children and pets away from area of operation.

DAMAGED, WORN OR LOOSE INLET / OUTLET HOSE CONNECTIONS WILL NEGATIVELY AFFECT YOUR PUMPS OPERATION.

Operation of Water Pump (continued)

Starting the Engine: Refer to the Controls and Features section for additional diagrams and definitions.

1. **PRIME THE PUMP.**
2. Move the fuel cock to the "ON" position.
3. To start a cold engine, refer to instruction in the Controls and Features section – "2. Choke lever". To restart a warm engine, leave the choke level in the "OPEN" position.
4. Move the throttle valve lever away from the "LOWER" position, about 1/3 of the way toward the "UPPER" position.
5. Turn the engine switch to the "ON" position.
6. Pull the recoil starting handle lightly until resistance is felt, then pull briskly. Do NOT allow the starter handle to snap back against the engine. Return it gently to prevent damage to the starter.

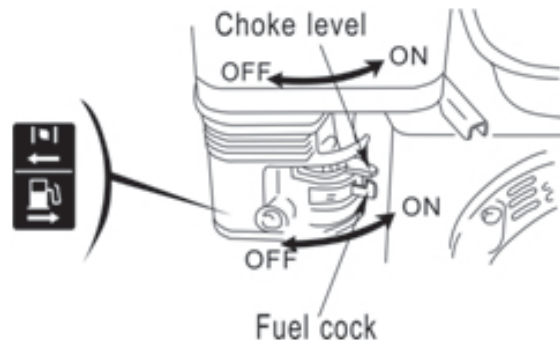

Setting the Engine Speed

1. After starting the engine, move the throttle valve lever to the "UPPER" position for self-priming, then check the pump output.
2. To adjust the pump output (which is controlled by the engine speed), move the throttle valve lever as needed to attain desired pump output. Moving the throttle valve in the "UPPER" direction will increase the pump output and moving the throttle valve in the "LOWER" direction will decrease pump output.

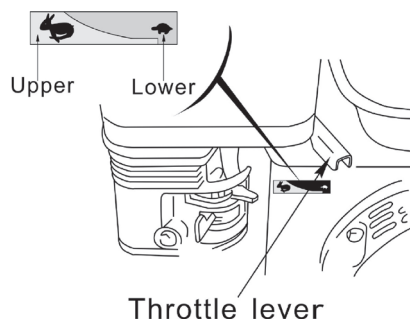

Operation of Water Pump (continued)

Your Semi-Trash or Trash Pump is manufactured to accept solids and debris up to ½ the size of the inlet and outlet diameters (i.e. a 3" pump will accept up to 1.5" solids and debris to move through the pump and grind it to exit through the outlet). Your pump has a removable front cover with clevises or T-bolts to remove the front cover to allow you to clean the pump housing should the debris clog your pump.



4 Clevis Front Cover Release ST3TWPLT-CA & ST4TWPLT-CA

6 T-Bolt Front Cover Release ST2TWPLT-CA Semi Trash Model

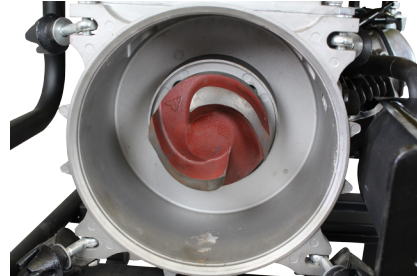
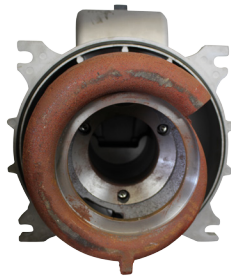

Stopping the Engine: Refer to the Controls and Features section for additional diagrams and definitions.

IN AN EMERGENCY:

1. Turn the engine switch to the "OFF" position.

NORMAL PROCEDURE:

1. Move the throttle valve lever to the "LOWER" position.
2. Turn the engine switch to the "OFF" position.
3. Turn the fuel cock to the "OFF" position.
4. Remove the water drain plug and drain the pump chamber.
5. Remove the water filler cap and flush the pump chamber with fresh, clean water.
6. Allow water to completely drain from the pump chamber.
7. Reinstall the water drain plug.
8. Reinstall the water filler cap.

Transporting and Storing the Unit



WARNING:

- To avoid fire, allow water pump to cool down for at least twenty minutes before transporting or storing the unit.
- Always transport and store the unit with the fuel cock in the “OFF” position.
- Always keep unit in horizontal, LEVEL position to the ground to prevent fuel from spilling. Spilled gasoline and gasoline vapor may ignite.
- Gasoline is extremely flammable and explosive.

Storing the Water Pump: Refer to the Controls and Features section for additional diagrams and definitions.

1. Ensure the storage site for the unit is clean and dry.
2. Clean the inside of the water pump.
 - a. If the water pump was used to pump water with mud, sand, or other heavy debris:
 - i. Operate water pump to suck in fresh, clean water to wash inside of unit. Failure to do so may result in damage to impeller.
 - ii. After washing, remove water drain plug and empty the water in the water pump completely.
 - iii. Reinstall the water drain plug.

Before long term storage of your power equipment product, typically 30 days or more, perform the following:

1. Set the fuel cock valve to the “OFF” position.
2. Let the unit continue to run until it stops itself, burning all of the fuel in the fuel system.
3. Turn the ignition switch to the “OFF” position.
4. Drain the engine oil in accordance with the “Oil Change Procedures” in this Owner’s Manual Maintenance section. Do NOT re-fill with oil until ready to use again.
5. Remove the spark plug in accordance with the “Spark Plug Maintenance” in the Owner’s Manual Maintenance section. Spray a lubricant, such as WD40®, into the spark plug hole to lubricate the top of the piston and walls of the cylinder. Replace the spark plug.
6. Pull starter rope until resistance is felt. This will place the valves in the closed position.
7. Add the recommended amount of fuel stabilizer, in accordance with the amount recommended by the manufacturer, to the unused gasoline left in the unit’s tank.
8. Place the unit in a clean, dry and secure location.
9. Cover the unit to protect it from dust.

Maintenance

MAINTENANCE SCHEDULE	
PROCEDURE	TIME
Engine Oil Check	Each Use
Replace Engine Oil	After Each 40 Hours of Use (For Initial Break in – After First (1st) 10 Hours of Use
Air Cleaner Filter	Check Each Use/Replace As Needed or After Every 100 Hours of Use
Impeller Check	After 300 Hours of Use or After First Year
Air Cleaner Wash	Check before each use/ Clean as needed/ Change ea. 100 hrs
Spark Plug	When Needed
Valve Clearance	Check & Re-adjust annually or after 300 Hours of Use
Fuel Tank	Replace Every 3 Years Based on Condition

NOTE: Refer to Following Procedures for proper method to perform maintenance

OIL CHANGE PROCEDURES:

Periodic maintenance of your engine oil should be performed after each 40 hours of use your Power Equipment Product. Check your engine oil level prior to each use.

1. Start your engine and let it warm up to get the oil warm and thinner. Remove the dipstick (refer to Controls and Features section) by turning counter clockwise. Remove the oil drain plus (refer to Controls and Features section) located below the dipstick utilizing the appropriate tools.

CAUTION: THE OIL MAY BE HOT.

2. Drain the engine oil into an approved receptacle and discard in accordance with all Federal and State Regulations. Never dump your used engine oil on the ground or into drains, only discard in an approved manner. Check with your local authorities to determine the regulations in your area.



WARNING! AVOID SPLASHING OF HOT OIL. IT CAN BURN YOU AND CAUSE SEVERE INJURY.

3. After oil is completely drained, replace oil drain plug and tighten with appropriate tools. Replace oil with the proper oil for your product. Refer to the Pre-Operating Instructions: Engine Oil Level Check section for exact fill requirements. Always use your dipstick to check the oil level and only fill to the full mark on the dipstick. Never overfill the engine, as this can cause damage to the unit and void warranty.
4. Replace the dipstick on your engine.

Maintenance (continued)

PROPER MAINTENANCE OF YOUR UNIT WILL INCREASE THE LIFE OF YOUR PRODUCT. THE OIL MUST BE CHANGED ON A REGULAR BASIS FOR PROPER OPERATION AND RELIABILITY AND TO ALSO MAINTAIN YOUR WARRANTY ON THIS PRODUCT.

AIR CLEANER MAINTENANCE:

1. Remove the clip (item 9 in "Air Cleaner A" below) or the wing nut (item 7 in "Air Cleaner B" below) to remove the check the air filter element.
2. For sponge type air filters, wash with soap and water when contaminated. Squeeze excess liquid from air filter element and allow the air filter element to dry. For paper type air filters, replace with the correct air filter for your unit. They are available at your dealer or from STANLEY®. Order your filter by calling toll free 1-877-684-8912.
3. Re-install the air filter element into the air filter housing.
4. Check before each use, clean when needed, replace at 100 hrs max of use.



WARNING!

Never use gasoline or other flammable solvents to clean the air filter. Use only household detergent soap to clean the air filter.

Use in dusty or dirty environments increases service intervals of both oil and air filter.

Maintenance (continued)

SPARK PLUG MAINTENANCE:

1. Remove spark plug cap (refer to "Spark Plug Cap Removal" figure below).
2. Remove spark plug with socket and handle supplied with your unit (refer to "Spark Plug Removal" figure below).
3. Clean any carbon build-up around the spark plug.
4. Check the spark plug gap and adjust if necessary. 0.30" gap.
5. Lubricate the threads of the spark plug with anti-seize compound or engine oil.
6. Re-install the spark plug and spark plug cap.

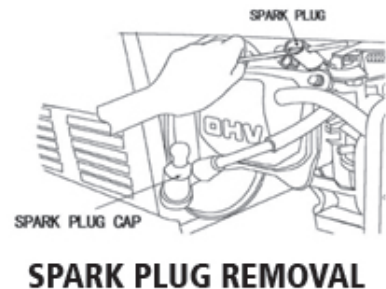

FUEL SYSTEM MAINTENANCE:

NOTE: Periodically you can get sediment or trash in your carburetor bowl. Use the following procedures to clean:

1. Turn the fuel cock (valve) to the "OFF" Position.
 2. Remove the carburetor bowl by removing the mounting bolt located at the bottom of the bowl.
 3. Dump out the old fuel and sediment into an approved container.
 4. Clean carburetor bowl thoroughly.
 5. Fit a new rubber washer into place and re-attach fuel bowl to the carburetor.
- NOTE: Removal of the drain screw at the bottom of the bowl can drain the fuel to remove smaller debris that has collected in the bowl.
6. After bowl is securely back in place, turn the fuel cock (valve) to the "ON" position for use.
 7. Units equipped with a pre-filter for fuel will have a filter housed just below the fuel cock. Remove the fuel filter element (refer to "Fuel Filter Element Removal") and clean or replace.

Maintenance (continued)

FUEL SYSTEM MAINTENANCE (continued):

(See diagram below) and either clean or replace the fuel filter element. Re-assemble the fuel filter element (refer to "Fuel Filter Element Assembly" diagram below).

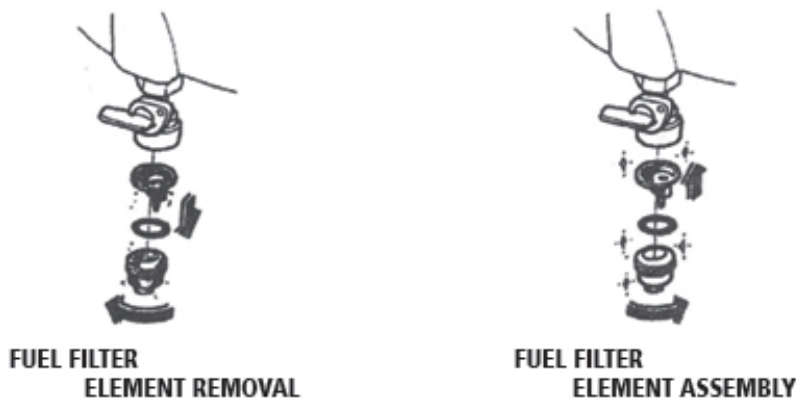

USAGE IN HIGH ALTITUDE REGIONS:

In regions with high altitude, the standard carburetor produces overly dense combinations of fuel and air, which result in decreased engine performance and increased fuel consumption. To maintain high engine performance at high altitudes, install a high altitude carburetor main spray nozzle and re-adjust the adjusting screw for idle speed. For usage in regions with an altitude of over 4,527 ft (1380m), contact your dealer to replace the standard carburetor and make needed adjustments in advance. Even with a proper high altitude carburetor spray nozzle installed in the engine, the power output of the engine will drop about 3.5% with every 1000 ft (305m) increase in altitude. If the standard carburetor jets are not replaced and adjusted for usage in high altitude, the increased altitude effect will be even more severe.

NOTE: Usage of the water pump in regions with lower altitude than the high altitude carburetor spray nozzle is applicable may result in decrease of engine performance. The engine may become overheated and over-lean, creating a combination of fuel and air produced which may cause severe damage to the engine.

Troubleshooting

IF THE ENGINE WILL NOT START:

1. Check to ensure switches are in the "ON" position.
2. Check engine oil level. The unit possesses a low oil shutdown feature that will not allow your engine to start if the oil is below safe operating levels. This feature is installed to increase the life of your engine and prevent engine damage. If oil level is low, fill to the full mark on dipstick. Refer to the Pre-Operating Instructions: Engine Oil Check section for exact oil type and amounts.
3. Check the fuel level to ensure adequate fuel. Add fuel if necessary.
4. Remove and inspect the spark plug for cleanliness and proper electrode gap. If needed, clean or replace the spark plug. Refer to Spark Plug Maintenance in the Maintenance section of the Owner's manual for proper procedure.
5. If the unit will still NOT start after performing the above checks, call our customer service line at STANLEY®, Toll Free 1-877-684-8912 or take the unit to an authorized service center.

NOTE: Periodically, on the initial start-up or after the unit has been stored for a long period of time, the float for your "Low Oil Shutdown" system will stick to the bottom of the oil pan. Locate the two (2) wires to the low oil sensor diode (figure "Low Oil Sensor Diode" to the right) located on the side of the engine block. Unplug these wires and, **only after ensuring the engine is full of oil**, start the engine and allow it to run until warm (normally 20 minutes, as this will heat the oil and release the float on the low oil shutdown system). Then, re-plug the wires to the terminals on the low oil shutdown sending unit.

IF THE WATER PUMP WILL NOT PUMP:

1. Check if there is ample water in the pump chamber to fully prime the pump.
2. Check if the filter is clogged on the suction hose.
3. Check if the hose clamp is securely tightened.
4. Check if the water hose is damaged.
5. Check if suction height required for the application is too high. Refer to Product Specifications section for unit maximum suction height.
6. If the water pump still will not pump water, call our Customer Service Hotline, Toll Free 1-877-684-8912 or take the unit to an authorized service center.

Water Pump Safety

- 1. Never pump gasoline or other flammable liquids.**
- 2. The dealer or customer helpline (1-877-684-8912) can instruct you on intended uses.**
- 3. Water pump must be placed on a level surface.**
- 4. Do NOT expose the water pump to extreme conditions. Excessive dust, moisture and corrosive vapors will damage the unit.**
- 5. Cooling slots must be kept clear of debris.**
- 6. Shut off water pump and take to a qualified service center if the water pump fails to operate properly.**

LIMITED WARRANTY POLICY

This warranty is limited to the following STANLEY® Water Pump products that are distributed by the EquipSource LLC, located at 2205 Industrial Park Road, Van Buren, AR 72956. Effective date is 06/18/2015.

LENGTH OF WARRANTY				
	Residential Use**			Commercial/Rental***
PRODUCTS COVERED	1st Year	2nd Year	3rd Year	Warranty not to exceed 300 hrs. Or terms listed below.
Water Pumps	Full unit parts and labor	Full unit parts only	Engine parts only	Full unit, 12 months parts and labor

** Residential Use is defined as items that are for personal use.

*** Commercial/Rental use is defined as any usage for income producing or other business related uses.

In order to qualify for the limited warranty the product(s) must be purchased in North America from an authorized STANLEY® dealer or a dealer authorized by STANLEY® to sell STANLEY® products. This warranty is non-transferable and applies only to the original purchaser. The supplied "Warranty Registration Card" must be completed and on file with American Warranty Service (at the supplied address), at the time that any warranty claim is made. The "Warranty Registration Card" must be submitted with a receipt of purchase which clearly states the date of purchase and where the purchase was made.

During the warranty period (stated above) STANLEY® and/or American Warranty Service will repair or replace, at its' option, any part that is proven to be defective in material or workmanship under normal usage. Repairs and/or replacement will be made without charge for parts or labor. All parts found to be defective must be returned to American Warranty Service at our direction. Upon reception of the parts a judgment as to the validity of the warranty claim will be determined. All parts replaced under warranty or any replacement of the complete unit will be considered part of the original product and replacement of any product, and any warranty on those parts or replacement unit will coincide with the original warranty.

To obtain Warranty Service, call our Customer Service Hotline at 1-877-684-8912 for Warranty Service. If your issue cannot be resolved through consultation with our Customer Service Representatives, you will be directed to an Independent Service Center of your choice nearest your location. Any manufacturer's defect of your product will be repaired or replaced at no charge to you per our commitment. If the issue with your unit is not a Manufacturer's Defect, you will be advised to make payment to the Service Center upon diagnosis of repairs which are not covered under the Manufacturer's Warranty Policy. At STANLEY®'s discretion; STANLEY® may elect to replace a defective unit. In this case the end user is responsible for all shipping and handling charges associated with the exchange and as stated above the warranty will coincide with the date of the original purchased unit.

This warranty is not valid for products or parts affected or damaged by accident, collision, normal wear, fuel contamination, abuse, neglect, misuse, alteration and/or unsuitable use or unauthorized parts replacement. Warranty becomes void if the customer fails to install, maintain, and/or operate the product in accordance with the instructions and recommended actions of STANLEY® set forth in the owner's manual. STANLEY® disclaims any responsibility for time loss or loss of usage of the product, transportation, commercial loss, or any other incidental or consequential damage. Prior to any warranty service an approval code must be issued to the service center in order for the warranty claim to be valid. Any implied warranties are limited to the duration of this written limited warranty. This warranty gives you specific legal rights, and you may also have other rights, which may vary from state to state.

OWNER'S RESPONSIBILITY

To ensure trouble free warranty coverage it is important that you register your STANLEY® Product by phone at 1-877-684-8912, or by filling out and returning to STANLEY® the warranty registration card supplied with your product.

This confirms your warranty coverage and provides a direct link between you and STANLEY® if we find it necessary to contact you. Your receipt for purchase including date, model and serial number must be maintained and registered to receive service from an Authorized Service Dealer for warranty service. Proof of purchase rests solely with you, the original purchaser.

You must demonstrate reasonable care and use, and follow preventive maintenance, storage, fuel and oil usage as prescribed in the operator's manual for your STANLEY® unit. For the warranty assistance from a STANLEY® Authorized Service Dealer nearest to you, call STANLEY®'s automated phone at 1-877-684-8912. Should you require assistance or have questions concerning STANLEY® products.

EXCLUSIONS

- STANLEY® Equipment that utilize non- STANLEY® replacement parts.
- Failure to perform "Periodic Maintenance" as required and specified in the supplied "Owner's Manual."
- Costs of normal maintenance and adjustments.
- Failures caused by any contaminated fuels, oils, or lack of proper oil levels.
- Repairs or diagnostics performed by individuals other than STANLEY® authorized dealers not authorized in writing by STANLEY®.
- Failures due to normal wear and tear, accident, misuse, abuse, negligence or improper use.
- As with all mechanical devices, the engines need periodic part(s) service and replacement to perform as designed. This warranty will not cover repair when normal use has exhausted the life of a part(s) or engine.
- Failures caused by any external cause or act of God, including but not limited to, collision, theft, vandalism, riot, war, fire, freezing, lightning, earth-quake, windstorm, hail, water, flood, tornado, or hurricane or any occurrence outside of normal use and activity .
- Damage related to any animal infestation to include rodent and/or insect infestation.
- Products that are modified or altered in a manner not authorized in writing by STANLEY®.
- Any incidental, consequential or indirect damages caused by defects in materials or workmanship, or any delay in repair or replacement of the defective part(s).
- Failure due to misapplication.
- Telephone, cellular phone, facsimile, internet access, or other communication expenses.
- Expenses related to "customer instruction" or troubleshooting where no manufacturing defect is found.
- Overnight freight or special shipping costs for replacement part(s).
- Overtime, holiday or emergency labor.
- Starting batteries, fuses, light bulbs and engine fluids.

DISCLAIMER OF IMPLIED WARRANTIES:

This limited warranty is in lieu of all other expressed or implied warranties, including any warranty of the unit's fitness for any particular use and any implied warranty of MERCHANTABILITY otherwise applicable to STANLEY® Equipment and its affiliated companies shall not be liable for any special, incidental or consequential damage, including lost profits. There are no warranties extended other than provided herein. This limited warranty may be modified only by STANLEY®. Any implied warranties allowed by law shall be limited in duration to the terms of the express warranty provided herein. Some states do not allow limitations on how long an implied warranty lasts, so the above limitation may not apply to you. Some states do not allow the exclusion or limitation of incidental or consequential damages, so the above limitation may not apply to you. This warranty gives you specific legal rights. You also have other rights from state to state. STANLEY®'s ONLY LIABILITY SHALL BE THE REPAIR OR REPLACEMENT AS STATED ABOVE. IN NO EVENT SHALL STANLEY® BE LIABLE FOR ANY INCIDENTAL OR CONSEQUENTIAL DAMAGES, EVEN IF SUCH DAMAGES ARE A DIRECT RESULT OF STANLEY®'s NEGLIGENCE. Some states do not allow the exclusion or limitation of incidental or consequential damages, so the above limitation may not apply to you. This warranty gives you specific legal rights and you may also have other rights from state to state.

OWNER'S WARRANTY RESPONSIBILITIES:

As the outdoor equipment owner, you are responsible for performance of the required maintenance listed in your owner's manual. STANLEY® recommends that you retain all receipts covering maintenance on your outdoor equipment. STANLEY® will not deny your warranty coverage based solely on your lack of receipts for service however, the condition of the equipment upon arrival at the service center will determine the warrantable nature of the product.

As the outdoor equipment owner, you should however be aware that STANLEY® may deny your warranty coverage if your outdoor equipment or a part has failed due to abuse, neglect, or improper maintenance or unapproved modifications.

If you have any questions regarding your warranty rights and responsibilities, you should contact STANLEY® or American Warranty Service Representative at 1-877-684-8912 or at the following address STANLEY® Water Pumps, 2205 Industrial park Road, Van Buren, AR 72956.

STANLEY®

Product Registration
Registracion del Producto
Inscription du Produit

WATER PUMPS



Postage
Stamp

Stanley Water Pumps
C/O American Warranty Service
 1200 Minters Chapel Road
 Suite #200
 Grapevine, TX 76051

STANLEY® and the STANLEY® Logo
 are trademarks of **STANLEY® Black & Decker, Inc.**
 or one of its affiliates, and are used under license.

Product Registration
Registracion del Producto
Inscription du Produit

Register Online at:

www.lifanpowerusa.com
 or complete the form and mail it
 to the address provided.
 Thank you for choosing
STANLEY® Water Pumps

Registrarse en Línea en:

www.lifanpowerusa.com
 o llene el siguiente formulario y envíelo
 por correo.
 Gracias por Elegir
STANLEY® Water Pumps

Inscrire en Ligne à:

www.lifanpowerusa.com
 ou Remplissez le Formulaire
 Ci-Dessous et le Courrier.
 Merci d'Avoir Choisi
STANLEY® Water Pumps

The Engine ID
 Number is
 stamped into the
 crankcase of
 your engine

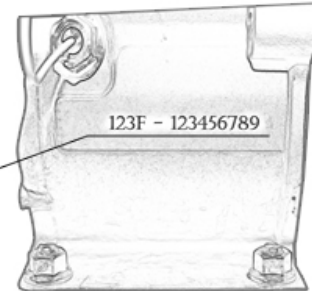

Model # / # del Modelo / # de Modèle _____ Engine ID # / # de ID del Motor / # d'ID du Moteur _____

Installer Contact Info / Información de Contacto del Instalador / les Coordonnées de l'Installateur _____

Owner / Dueño / Propriétaire _____ Phone # / Teléfono / Téléphone _____

Address / Dirección / Adresse _____

City / Ciudad / Ville _____ State / Estado / État _____ ZIP Code / C.P. / ZIP _____

E-Mail _____

Purchase Date / Fecha de Compra / Date d'Achat _____ Store / Tienda / Magasin _____ Commercial / Residential?

Month / Mes / Mois _____ Day / Día / Jour _____ Year / Año / Année _____

Toll Free / Número Gratuito / Sans Frais:
Phone: 1-888-926-4313

Please read this Owner's Manual carefully before operating your new Water Pump.

This Owner's Manual includes the operation of models: ST2STWPLT-(CA), ST3TWPLT-(CA) & ST4TWPLT-(CA)

Thank you for purchasing our STANLEY® Trash Water Pump!

All information in this publication is based on the latest product information available at the time of approval for printing. We reserve the right to make changes at any time without notice and without incurring any obligation. The copyright of this manual belongs to EquipSource, LLC. No parts of this publication may be reproduced without the written consent of EquipSource, LLC. This manual should be considered a permanent part of the generator and should remain with it if it is resold.

FOR ALL WARRANTY AND SERVICE RELATED ISSUES/QUESTIONS DO NOT RETURN YOUR UNIT TO THE STORE OR DEALER WHERE THE ITEM WAS PURCHASED. FOR SERVICE PLEASE CALL THE STANLEY® CUSTOMER SERVICE HOTLINE AT 1-877-684-8912. WE WILL BE HAPPY TO HANDLE YOUR WARRANTY ISSUE OR DIRECT YOU TO THE NEAREST "AUTHORIZED SERVICE CENTER."



Please read this manual carefully before operating your new Water Pump.

Pre-Drilled & Tapped for Optional Wheel Kit - Part #STWKT

Thank you for purchasing our Pro Series Water Pump. This manual includes the operation and maintenance of the 2, 3 & 4 inch Trash Water Pumps.

"CA" in the model number means the unit is
California CARB certified.

All information in this publication is based on the latest product information available at the time of approval for printing. We reserve the right to make changes at any time without notice and without incurring any obligation. The copyright of the manual belongs to our company. No parts of this publication may be reproduced without our written permission. This manual should be considered a permanent part of the water pump and should remain with it if it is resold.

**For Product Support
please visit us at www.lifanpowerusa.com
or call Toll Free 1-866-471-7464**

For all warranty and service related issues/questions
DO NOT RETURN YOUR UNIT TO THE STORE OR DEALER WHERE THE ITEM WAS PURCHASED.

For service, please call the customer service hotline at 1-877-684-8912.

We will be happy to handle your warranty issue
or direct you to the nearest "authorized service center".

**STANLEY® and the STANLEY® Logo
are trademarks of 2015 STANLEY® Black & Decker, Inc.
or one of its affiliates, and are used under license.**

**Products are manufactured by
LIFAN Power USA
2205 Industrial Park Rd
Van Buren, AR 72956**