

SUREBONDER®

Model 9750 2" Brad Nailer



2" 18 gauge Brad Nailer

Includes: 2 Allen wrenches & pneumatic tool oil

Operating Instructions

Read All Safety Rules and Instructions Carefully
Save this manual for Future Reference

WARRANTY

If you have any problems with this tool, please call FPC Corporation toll-free at 1-800-860-3838 before returning it to the place of purchase.

FPC Corporation warrants this product to be free from defects in material and workmanship, under normal conditions of use and when used in accordance with FPC operating instructions, for a period of 90 days from the date of purchase by the user. Within the 90 day warranty FPC at its option shall repair or replace product. This product must be returned at the distributor/user expense, either within warranty or out. Repaired or replaced products will receive a 60 day warranty. USER MUST BE USING THE PROPER NAILS FOR THIS WARRANTY TO BE VALID. WARRANTY IS VOID IF INCORRECT TYPE OF NAILS ARE USED.

Visit us at surebonder.com for our full line of products

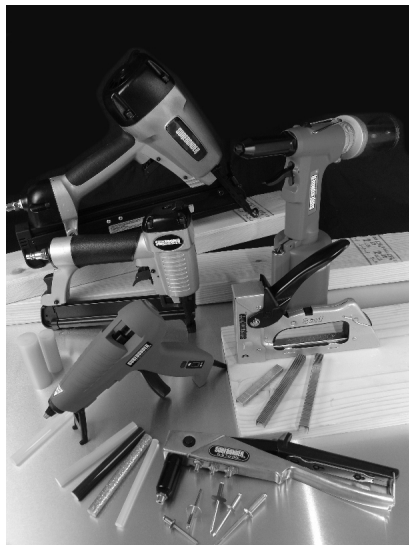

FPC Corporation - 355 Hollow Hill Drive - Wauconda, IL 60084
Phone: (847) 487-4583 Fax: (847) 487-0174
website: www.surebonder.com e-mail: sales@surebonder.com

! DANGER

Improper use of this nailer can result in death or serious injury. This manual contains important information about product safety. Read and understand this entire manual before operating this nailer

IMPORTANT SAFETY WARNINGS:

THE SAFETY WARNINGS BELOW CANNOT COVER ALL POSSIBLE SITUATIONS THAT MAY OCCUR. THESE BASIC SAFETY PRECAUTIONS SHOULD ALWAYS BE FOLLOWED TO PROTECT AGAINST PERSONAL INJURY TO THE OPERATOR OR OTHER PERSONNEL IN THE AREA, AS WELL AS DAMAGE TO THE EQUIPMENT. READ AND UNDERSTAND THESE WARNINGS BEFORE USING EQUIPMENT.

Keep tool away from children, and DO NOT allow children near work area. Do not allow children or untrained personnel to handle this nailer.

DO NOT operate this nailer while tired, or under the influence of drugs, alcohol, or medication that makes you drowsy.

Never point the nailer at yourself or others - always assume that the nailer is loaded, and proceed with caution.

Wear safety glasses and ear protection. The nailer operator and all personnel in the work area must wear safety glasses that protect the front and side, to avoid eye injury. Ear plugs should be worn to avoid hearing damage.

If operator will be working in a situation where overhead work will be done (i.e. on a ladder, stairs, or scaffolding) a hard hat must be worn.

Never wear loose clothing or jewelry because it can get caught in the moving parts of this nailer. Make sure long hair is covered, to avoid getting it caught in nailer.

Keep the nailer pointed away from yourself and others at all times. Keep hands and all body parts away from rear area of nailer (near air hose) to guard against injury. Keep hands and feet away from firing head during use.

Keep proper balance and footing at all times - do not over-reach.

Never use oxygen, bottled gas or any type of combustible fuel as a power source - it can cause an explosion and serious injury.

Do not use near flammable liquids or gases - the nailer sparks during operation, and could cause an explosion and serious injury.

Use an air hose that will withstand at least 150 psi, OR 150% of the maximum pressure of the compressor.

Never connect this tool to compressed air if the pressure could exceed 200 psi, as the nailer could burst. Use only clean, dry, regulated compressed air, with pressure not exceeding 100 psi.

Do not use a non-relieving coupler with this nailer - if used, the nailer could remain charged with air after disconnecting, and would still be able to drive a nail even after being disconnected. The nailer and air hose must have a coupling so that all pressure is removed from the nailer when the coupling is disconnected.

Do not depress the trigger or safety mechanism while loading nails - accidental firing of a nail can occur. Keep your fingers away from the trigger when not firing nails. Always keep the nailer pointed downward during loading.

Do not use an air hose that is too long - nailer operator can trip over it. Make sure all connections are tight.

(WARNINGS continued next page)

Parts List

Seal Kit #9750-400 Includes:		Fastener Kit #9750-420 Includes:		Parts Sold Separately	
Diagram No.	Description	Diagram No.	Description	Part No.	Price Each
4	O-RING 8*2.5	1	SCREW 4*8	3	EXHAUST VALVE COLLAR Not Available
8	GASKET	2	WASHER	7	CYLINDER CAP Not Available
9	SEAL, AIR	5	SCREW 5*30	14	FIRING VALVE PISTON Not Available
12	O-RING 13.8*2.4	6	WASHER #5*1.1t	23	PISTON HEAD Not Available
13	O-RING 31*2.5	10	SPRING	26	CYLINDER Not Available
15	O-RING 25*3.5	11	WASHER	29	BODY Not Available
17	O-RING 22.9*2.7	16	STOPPER	35	REMOTE CORE Not Available
24	O-RING 39.4*3.1	25	SPACER	37	REMOTE HOUSING Not Available
27	BUMPER	28	PIN RETAINER 6.5*2	39	RELEASING BLADE Not Available
31	O-RING 8*1.8	30	NOZZLE	41	TRIGGER Not Available
34	O-RING 2.6*1.2	32	UPPER HOUSING	44	GRIP Not Available
36	O-RING 12.5*1.8	33	SPRING	47	TAIL COVER Not Available
38	O-RING 14*1.8	40	SPRING	50	CLICK LEVER Not Available
48	O-RING	42	PIN 2.5*16.8	52	CATCH GUIDE PLATE Not Available
Drive Pin Kit #9750-410 Includes:		43	PIN RETAINER 3.1*2.9	54	RELEASE CATCH(B) Not Available
84	DRIVE PIN ASSEMBLY	45	GRIP	56	RELEASE CATCH(C) Not Available
84	DRIVE PIN ASSEMBLY	46	SPRING PIN 3*24	57	DRIVER GUIDE Not Available
84	DRIVE PIN ASSEMBLY	49	SPRING	61	RELEASE CATCH COVER Not Available
84	DRIVE PIN ASSEMBLY	51	PIN	62	CLICK LEVER SET Not Available
84	DRIVE PIN ASSEMBLY	53	SPRING	65	RELEASE CATCH(A) Not Available
84	DRIVE PIN ASSEMBLY	55	SCREW	67	DRIVER GUIDE COVER Not Available
84	DRIVE PIN ASSEMBLY	58	SCREW 4*18	70	LOWER MAG Not Available
84	DRIVE PIN ASSEMBLY	59	SPACER	71	STEEL BAR Not Available
84	DRIVE PIN ASSEMBLY	60	SCREW 5*16	72	PUSHER Not Available
84	DRIVE PIN ASSEMBLY	63	PIN	73	SPRING HOLDER Not Available
84	DRIVE PIN ASSEMBLY	64	GRIP	76	MAGAZINE SUPPORT Not Available
84	DRIVE PIN ASSEMBLY	66	SPRING	79	TAIL COVER Not Available
84	DRIVE PIN ASSEMBLY	68	SCREW 3*10	81	UPPER MAG Not Available
84	DRIVE PIN ASSEMBLY	74	SPRING	88	CLICK LEVER Not Available
84	DRIVE PIN ASSEMBLY	75	SCREW 5*12	Kit	
84	DRIVE PIN ASSEMBLY	77	STOPPER	Prices	
84	DRIVE PIN ASSEMBLY	78	SCREW 4*12	9750-400	SEAL KIT Call
84	DRIVE PIN ASSEMBLY	80	SPRING PIN 3*12	9750-410	DRIVE PIN KIT Call
84	DRIVE PIN ASSEMBLY	82	SCREW	9750-420	FASTENER KIT Call
84	DRIVE PIN ASSEMBLY	89	SPRING		
84	DRIVE PIN ASSEMBLY	90	SUPPER		

To order parts go to: www.surebonder.com

Parts List For Air Nailer 9750

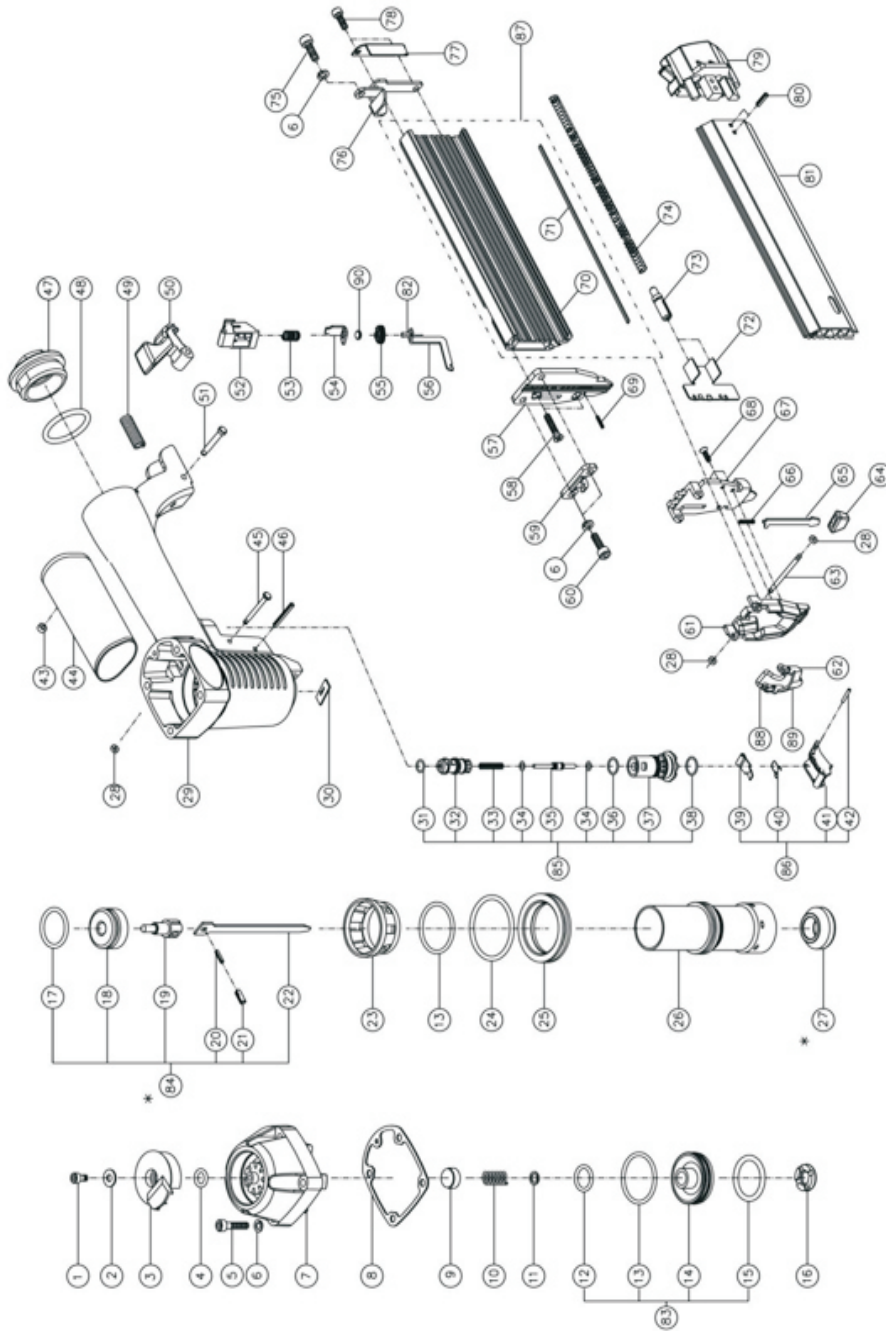

IMPORTANT SAFETY WARNINGS: continued

Disconnect air hose from nailer:
before performing maintenance.
when clearing a jam.
when tool is not in use.
when moving it to another location.
when handing nailer to another person.

DO NOT place finger on trigger when disconnecting air hose - the nailer could fire when reconnected to the air supply.

Carry nailer by the handle only, not by the air hose.

Do not drive nails close to the edge of the workpiece. It could split, allowing a nail to fly or ricochet and causing personal injury. Do not try to drive nails at too steep an angle. Make sure nailer is held firmly during firing to minimize recoil.

Do not drive a nail into very hard material, thin material, or on top of an existing nail- the nail could ricochet, causing personal injury.

Never use the nailer if it is leaking air, the contact safety mechanism is not working, nailer has missing or damaged parts, or requires repair. Make sure all screws and caps are securely tightened.

Inspect the nailer before each use to insure that the trigger, safety mechanism, and spring are operating properly. Lock the nailer in a clean, dry storage area between uses.

Only use parts, nails, and accessories supplied or recommended by FPC Corporation. Unauthorized parts or fasteners can lead to malfunction and serious injury. Only personnel trained by FPC Corporation or the distributor shall repair the product. Do not modify this tool in any way.

Never use in presence of flammable liquids or gases. The nailer produces sparks during operation.

Never use the nailer in sites containing lacquer, paint, benzene, thinner, gasoline, gases, adhesive agents, and other materials which are combustible or explosive.

Check for live wires. Avoid the risk of electrical shock by checking for live wires that may be hidden by walls, floors, or ceilings. Turn off the breaker switch pertaining to that work area.

Do not store the nailer in a cold weather environment. Keep the nailer in a warm area until the start of work. If it is in a cold area, bring it in a warm area and allow it to warm up before use.

Manufacturer assumes no responsibility for consequential or indirect damages from the use of this product.

Save this manual and have it available for tool operators reference!

California Proposition 65

You can create dust when you cut, sand, drill or grind materials such as: wood, paint, metal, concrete, cement, or other masonry. This dust often contains chemicals known to cause cancer, birth defects or other reproductive harm. Wear protective gear.

APPLICATIONS

Including but not limited to: Cabinets, Picture Frames, Trim, Furniture Repair, Baseboards, Chair Rails

FEATURES

- Adjustable Exhaust
- Soft Grip handle reduces fatigue
- Contact safety mechanism - for safe operation
- Protective tip prevents surface damage
- Fast easy loading

AIR SUPPLY



NEVER use oxygen or other bottled gases. Explosion may occur.

This nailer is designed to operate on clean, dry, regulated compressed air, between 60 and 100 psi. It is preferable to include an air filter, pressure regulator, and automatic oiler within 15 feet of the tool, if possible.

An air filter is needed to remove contaminants and moisture that are contained in compressed air; filtering will significantly prolong the life of the tool. If an automatic oiler is not installed, place 2 to 3 drops of oil into the tool's air inlet twice a day. Do not install a quick coupler directly into the tool. Higher pressure drastically reduces tool life.

The nailer comes factory-equipped with a male quick connector. The nailer must always be connected to the air supply with a coupling that removes all pressure when it is disconnected.

NOTE: all components used with this nailer (air hose, connectors, regulators, filters, etc) must be rated at 120 psi, OR 120% of the maximum compressor potential, whichever is higher. Do not connect this nailer to a system with maximum potential air pressure greater than 200 psi.

AIR CONNECTION SET UP

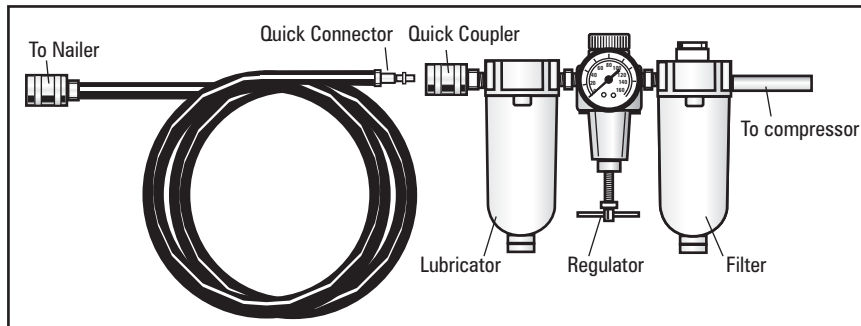

Troubleshooting

The following form lists the common operating system with problems and solutions. Please read the form carefully and follow it.

WARNING: If any of the following symptoms appears during your operation, stop using the tool immediately, or serious personal injury could result. Only a qualified persons or an authorized service center can perform repairs or replacement of tool. Disconnect tool from air supply before attempting repair or adjustment. When replacing O-rings or cylinder, lubricate with air tool oil before assembly.

Problem	Check	Correction
Nailer operates but no nail is driven.	Check for jam	Clear a nail jam.
	Check feeder function	Clean and lubricate.
	Check for proper nails	Use correct nails.
Weak drive. Slow to cycle.	Check air pressure	Increase air pressure. Do not exceed 120 psi. Use pneumatic oil.
	Drive blade worn?	Purchase Drive Pin Kit #9750-410.
	Piston O-ring worn or damaged?	Purchase Seal Kit #9750-400.
Drives too deep.	Check air pressure.	Reduce air pressure 60-100 psi.
Skipping nails, Intermittent feed.	Check for proper nails.	Use only recommended nails.
	Check nail feeder function	Clean and lubricate. Use pneumatic oil.
	Piston O-ring cut or worn out?	Purchase Seal Kit #9750-400.
	Check for proper nails.	Use only recommended nails.
Nails jam, Driven nail is bent	Drive blade worn?	Purchase Drive Pin Kit #9750-410.
Drives properly at normal speed but does not drive fully drive at faster nailing speed.	Check inside hose diameter.	Use larger air hose.

Loading Nails (continued)

To load:

Detach nailer from air supply. Push magazine release to release magazine cover. Do not load with contact safety mechanism or trigger depressed. Slide magazine cover towards the front of the magazine and lock closed.

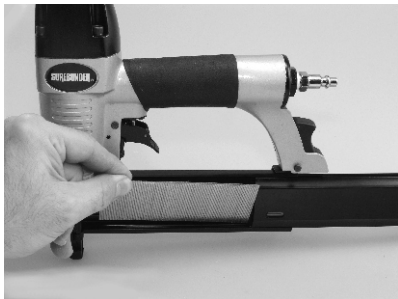

Drop in nails.

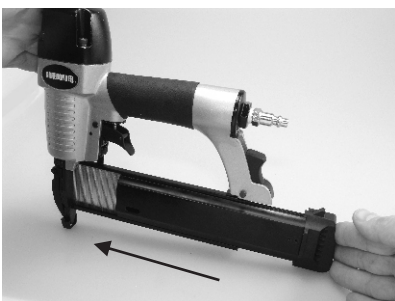

Push magazine cover closed until it locks.



Depth Adjustment

Using thumb screw to achieve desired depth.

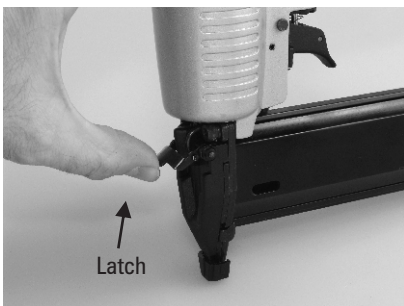

Latch



Jam Clearing Lift up on latch and swing guide plate outward. Remove jammed nail, replace guide plate catch and push latch down.

Exhaust Deflector Exhaust deflector can be positioned to point in any 360° direction. Reposition deflector by rotating to the desired position.

OPERATION



Depth Adjustment Knob
Turn knob clockwise for more depth
Turn knob counter-clockwise for less depth

SPECIFICATIONS

Overall Dimensions: 9.65" x 9.61" x 2.08"
Capacity: 100 nails
Nail Length: 3/4" - 2"
Nail size: 18 Gauge
Operating Pressure: 60 - 100 PSI (4-7 bar)
Air Inlet Size: 1/4" N.P.T
Weight of Tool: 2.82lbs.

NAIL SELECTION

Use SUREBONDER 400 Series
18 gauge brad nails
3/4" to 2".

Min	Max
<p>min. 3/4" (19 mm)</p>	<p>max. 2" (51 mm)</p>

18
Gauge

Mode of Operation

This nailer is equipped with a contact safety mechanism and does not operate unless the contact mechanism is depressed. There is only one method of operation to drive nails with this nailer.

- Intermittent operation (Trigger fire).
- Position the nail outlet on the workpiece with finger off the trigger.
- Depress the push lever firmly until it is completely depressed.
- Pull the trigger to drive a nail.
- Remove finger from the trigger.
- To drive another nail, move the nailer along the workpiece and repeat this procedure.

In order to avoid double fire:

- Do not push nailer on workpiece with strong force.
- Take nailer away from workpiece using recoil.
- Release trigger quickly when performing trigger fire.
- Do not drive nails into thin boards or near corners and edges of work piece.
- Nails can be driven through or away from workpiece and hit someone.
- Never drive nails from both sides of a wall at the same time. Nails can be driven into and through the wall and hit a person on the opposite side.
- Never use nailer which is defective or operating abnormally.
- Do not use nailer as a hammer.

MAINTENANCE

Lubrication

It is important that the nailer be properly lubricated. Without proper lubrication the nailer will not work properly and parts will wear prematurely. Use pneumatic tool lubricant. Do not use detergent oil or additives. These lubricants will harm the O-rings and other rubber parts. This will cause the nailer to malfunction. Filter-regulator-lubricator units should always be used. Keep the lubricator filled with pneumatic tool lubricant. If a lubricator is unavailable supply 2 - 3 drops of pneumatic tool lubricant into the air inlet.

Cold Weather Care

Do not store the nailer in a cold weather environment. If the nailer is cold bring the nailer into a warm area and allow to warm up before use. To warm the nailer: Reduce the air pressure to 40 psi (2.8bar 2.8kgf/cm²). Remove all nails from the nailer. Connect the air hose and blank-fire the nailer. The lowered air pressure will be enough to blank-fire the nailer. Slow speed operation of the nailer tends to warm the moving parts.

Inspecting the magazine

Disconnect the air hose. Keep magazine and nose of tool clean and free of any dirt, lint or abrasive particles. Clean the magazine by removing plastic debris wood chips which may have accumulated in the magazine. Lubricate it with pneumatic tool lubricant.

Storing

When not in use for an extended period of time apply a thin coat of pneumatic tool lubricant to the steel parts in order to avoid rust. Do not store the nailer in a cold weather environment. Keep the nailer in a warm and dry place.

Adjusting Air Pressure



WARNING

Do not exceed 100 psi. Adjust the air pressure at recommended operating pressure 60 to 100 psi according to the length of nails and the hardness of the workpiece.

The correct air pressure is the lowest pressure which will do the job. Using the Nailer at a higher than required air pressure unnecessarily over stresses the Nailer.

Testing The Nailer



DANGER



ANSI Z87.1

Operators and all others within the work area must wear safety glasses with side shields conforming to ANSI Z87.1 specifications.

Before actually using the nailer test the nailer using the checklist below.

Disconnect air hose connection from the nailer. Remove all nails for the nailer.

1) Pull the trigger and push the contact safety mechanism.
THE CONTACT SAFETY MECHANISM AND TRIGGER MUST MOVE FREELY.

2) Adjust the air pressure to 60 psi (4.9 bars 5 kgf/cm²).

Connect air hose.

DO NOT LOAD NAILS IN THE NAILER.

THE NAILER MUST NOT LEAK AIR.

3) Hold the Nailer downward without touching the workpiece with the contact safety mechanism.

Pull and hold the trigger for 5 seconds or longer.

THE NAILER MUST NOT OPERATE.

4) Remove your finger from the trigger and press the contact safety mechanism to the workpiece.

THE NAILER MUST NOT OPERATE.

5) If no abnormal operation is observed, you may load nails in the Nailer. If abnormal operation occurs, stop using the nailer and contact the service center immediately.

Loading Nails



WARNING

When loading nails into Nailer:

Disconnect tool from compressed air supply.

Do not depress trigger.

Do not depress the contact safety mechanism.

Keep Nailer pointed downward.