

SIMPLI™
H O M E

WyndentHall™
HOME DECOR
brooklyn + max™

AVINGTON / MIA / HAYES

BATH STORAGE TOWER

MODEL # AXCBC-002-WH

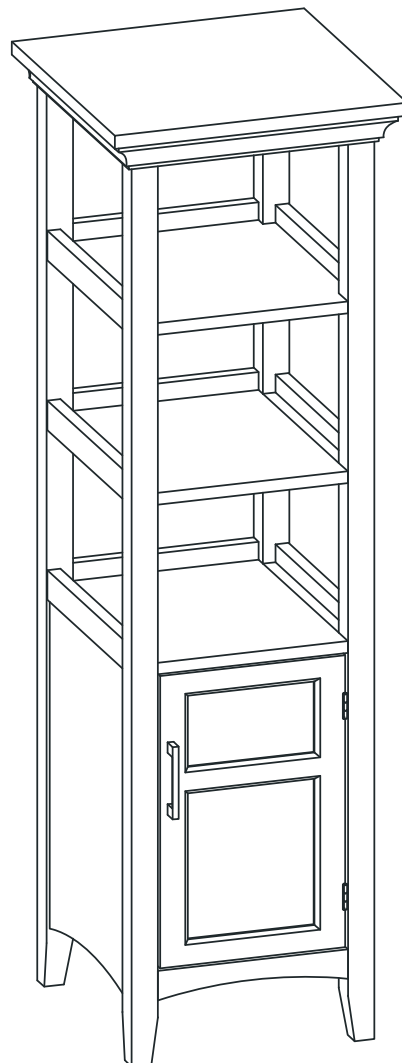



**FOR REPLACEMENT PARTS OR HELP WITH
ASSEMBLY PLEASE CONTACT US AT:**

simpli-home.com/customer-support

**PLEASE ENSURE TO HAVE THE MODEL #
FROM THE PACKAGING OR INSTRUCTION BOOKLET**

**TO RETURN THE PRODUCT:
PLEASE CONTACT THE RETAILER
WHERE THE ITEM WAS PURCHASED FROM**

SIMPLI[™]
H O M E

Wyndent Hall[™]
HOME DECOR
brooklyn + max[™]

**ENTER
TO WIN**

**Upload an image of our furniture
in your home with a short review
to our facebook page for a chance to**

**Win up to \$3000 of
Simpli Home furniture!!!**

www.facebook.com/simplihomefurnishings



IMPORTANT : Please read this manual carefully before beginning assembly of this product. Keep this manual for future reference.

SAFETY INFORMATION

Identify all the parts and hardware. Do not discard of the packaging until you have checked that you have all of the parts and hardware required. Hardware package may have spare parts.

WARNING: This item contains small parts which can be swallowed by children and pets. Keep children and pets away during assembly. To avoid danger of suffocation, always keep plastic bags away from children and pets. We recommend that you assemble this unit on a carpeted floor to avoid scratches. If using power tools, set the tool to low torque to avoid damage.

May require 2 people for ease of assembly.

CARE and MAINTENANCE

To clean, use a soft or slightly damp cloth, then wipe with a clean, dry cloth. Dust with soft dry cloth.

Do not use ammonia-based cleaning products, as they will damage the finish.

Do not leave liquids or damp cloths on this furniture.

To avoid dulling of the finish, do not place furniture in direct sunlight.

Please inspect and tighten all screws or bolts on a regular basis to ensure proper performance and safety of your item.

PARTS DESCRIPTION

A

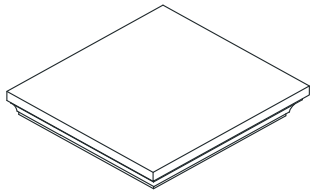

CABINET TOP
QTY 1

B

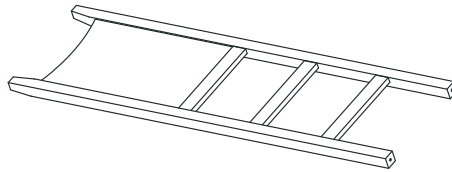

LEFT SIDE PANEL
QTY 1

C

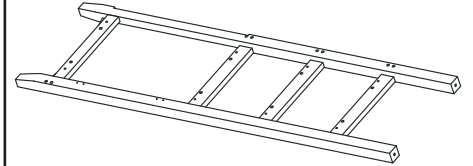

RIGHT SIDE PANEL
QTY 1

D

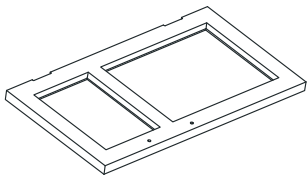

DOOR
QTY 1

E

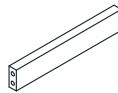

REAR BAR
QTY 2

F

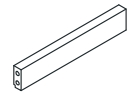

BOTTOM REAR BAR
QTY 1

G

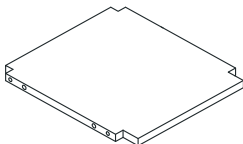

SHELF
QTY 3

H

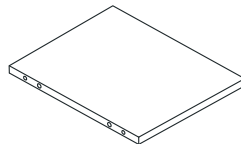

BOTTOM SHELF
QTY 1

I

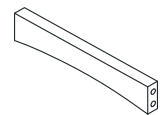

CROSS BAR
QTY 1



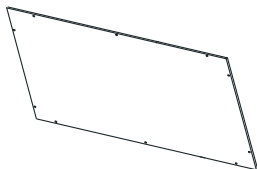









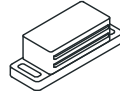

J

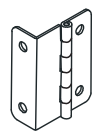

BACK PANEL
QTY 1

NEED HELP? For help with assembly or if you are missing a part,
Please call customer service at 1-866-518-0120 ext. 262 (9 am to 4 pm EST)

HARDWARE DESCRIPTION

<p>AA</p>  <p>WOOD DOWEL QTY 32</p>	<p>BB</p>  <p>CAM BOLT QTY 20</p>	<p>CC</p>  <p>CAM LOCK QTY 20</p>
<p>DD</p>  <p>SCREW QTY 10</p>	<p>EE</p>  <p>SCREW QTY 2</p>	<p>FF</p>  <p>MAGNET QTY 1</p>
<p>GG</p>  <p>SCREW QTY 2</p>	<p>HH</p>  <p>HANDLE QTY 1</p>	<p>II</p>  <p>SCREW QTY 1</p>
<p>JJ</p>  <p>PLASTIC ANCHOR QTY 1</p>	<p>KK</p>  <p>SCREW QTY 9</p>	<p>LL</p>  <p>METAL HINGE QTY 2</p>
<p>MM</p>  <p>METAL PLATE QTY 1</p>	<p>NN</p>  <p>BRACKET QTY 2</p>	<p>OO</p>  <p>SCREW QTY 1</p>
<p>PP</p>  <p>CABLE QTY 1</p>		

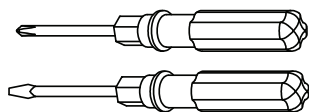

Required -
Flathead screwdriver
Phillips screwdriver
Rubber mallet
Not Included

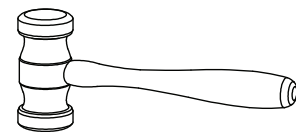

NEED HELP? For help with assembly or if you are missing a part,
Please call customer service at 1-866-518-0120 ext. 262 (9 am to 4 pm EST)

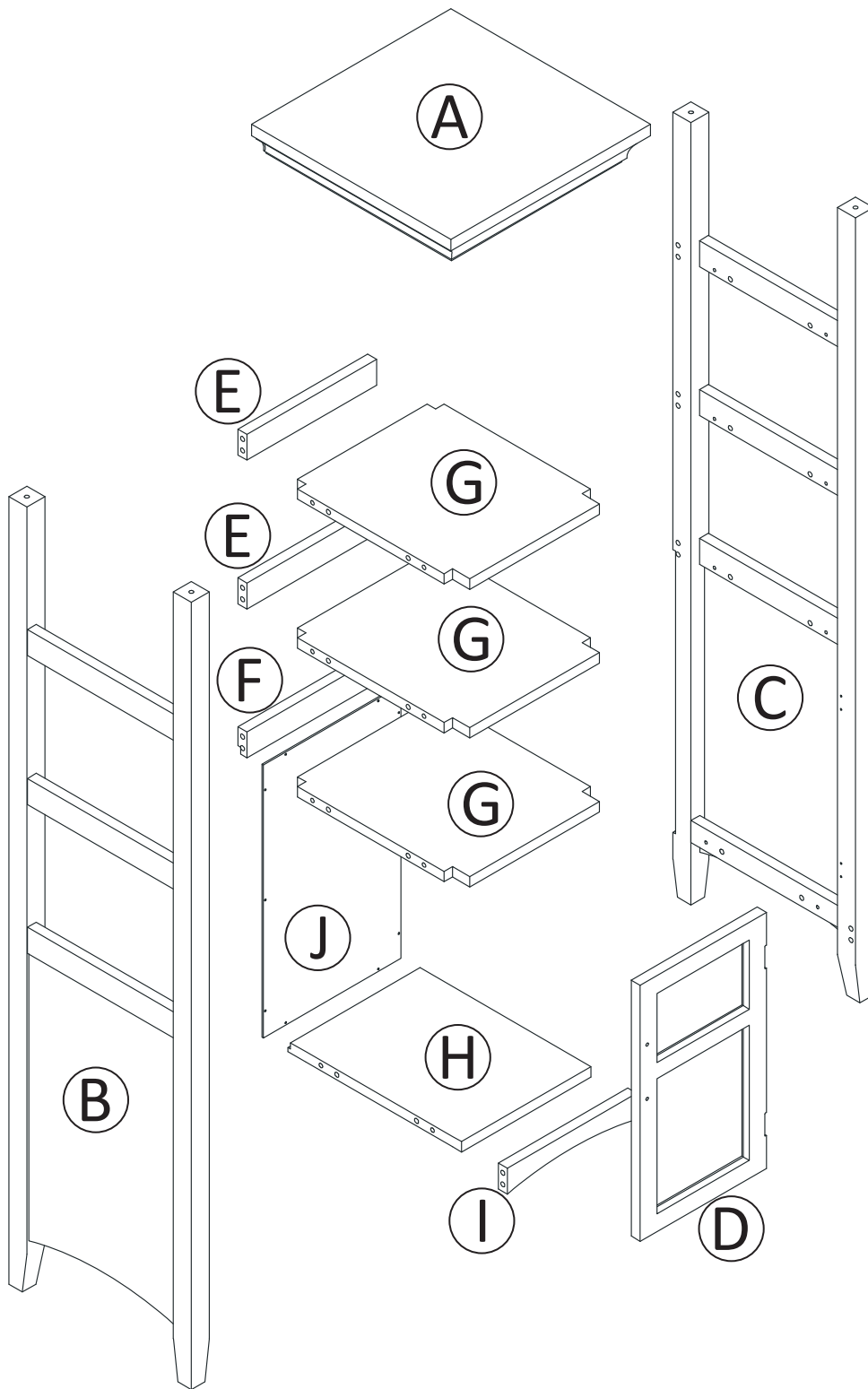

STEP 1

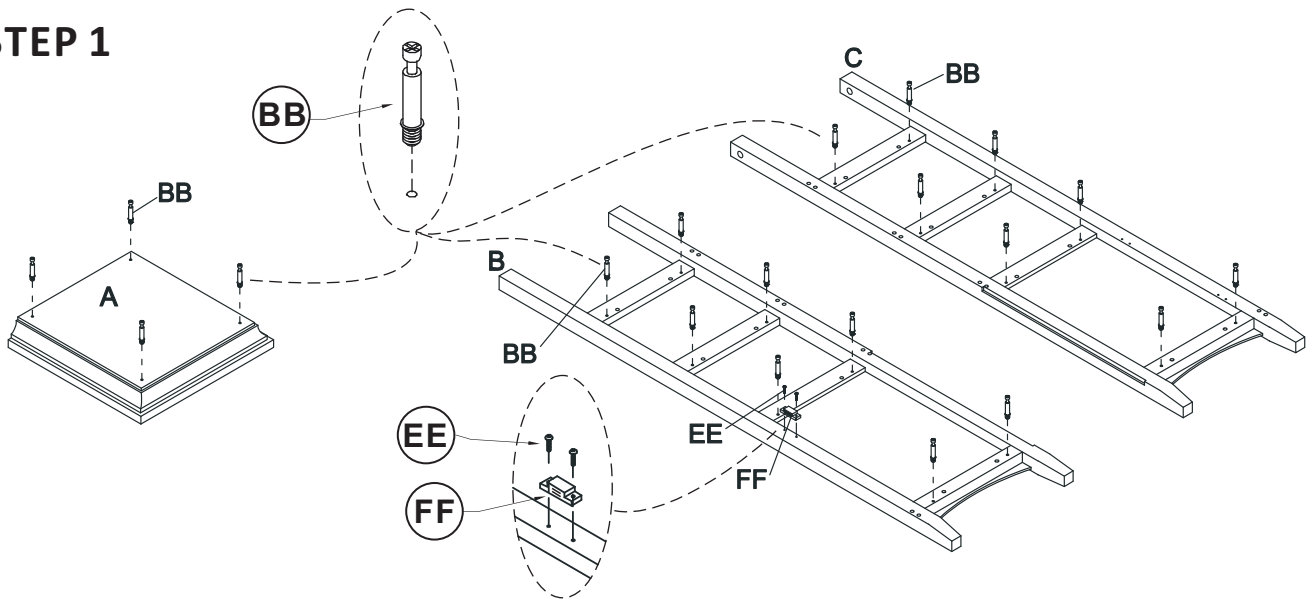

Assembling the Cabinet Top, Left Side Panel and Right Side Panel

1. Lay down the cabinet top (A) and screw four cam bolts (BB) into the pre-drilled holes using a Phillips screwdriver.
2. Lay down the left side panel (B) and screw eight cam bolts (BB) into the pre-drilled holes using a Phillips screwdriver.
3. Insert two screws (EE) through holes on magnet (FF) and tighten to left side panel (B) using a Phillips screwdriver.
4. Lay down the right side panel (C) and screw eight cam bolts (BB) into the pre-drilled holes using a Phillips screwdriver.
5. Do not over-tighten.

STEP 2

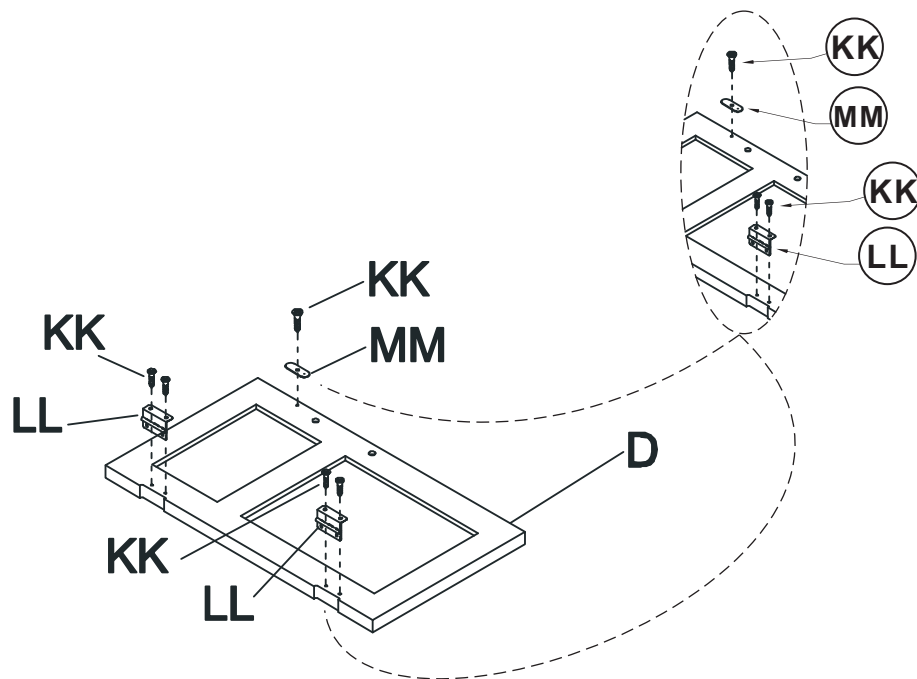

Assembling the Door

1. Lay down the door (D) and attach two metal hinges (LL) to the door (D) by inserting four screws (KK) through the holes on the metal hinges (LL). Tighten to the door (D) using a Phillips screwdriver.
2. Attach the magnet plate (MM) to the door (D) by inserting one screw (KK) through the hole on the magnet plate (MM) and tighten to the door (D).

STEP 3

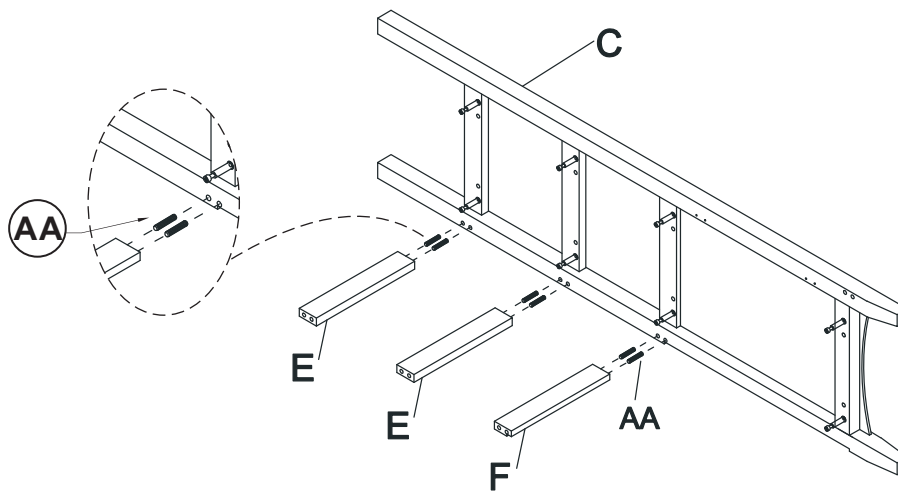

Assembling the Rear Bars

1. Attach the rear bars (E) and (F) to the right side panel (C) by inserting six wood dowels (AA) through the holes on the rear bars (E) and (F).

STEP 4

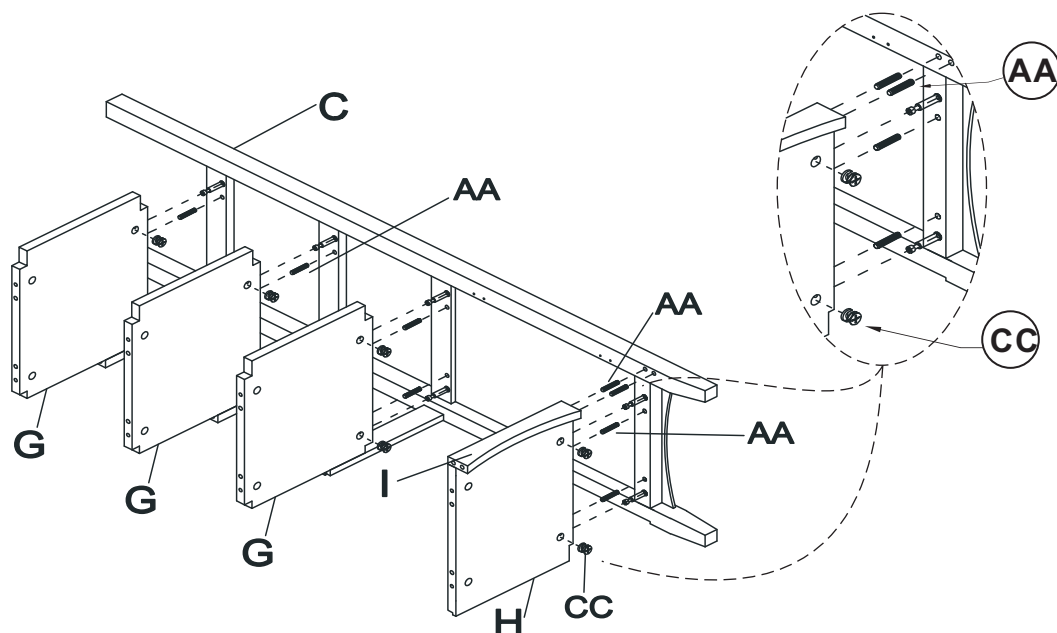

Assembling the Shelves, Bottom Shelf and Cross Bar

1. Attach three shelves (G) to the right side panel (C) by inserting six cam locks (CC) into cam lock holes. Rotate clockwise to secure the cam locks (CC) in place using a Phillips screwdriver. In the meanwhile inserting six wood dowels(AA) into the holes.
2. Attach the bottom shelf (H) to the right side panel (C) by inserting two cam locks (CC) into the cam lock holes on the right side panel (C) and rotate clockwise to secure cam bolts in place using a Phillips screwdriver. In the meanwhile inserting two wood dowels(AA) into the holes.
3. Attach the cross bar (I) to the right side panel (C) by inserting two wood dowels (AA) through the holes.

STEP 5

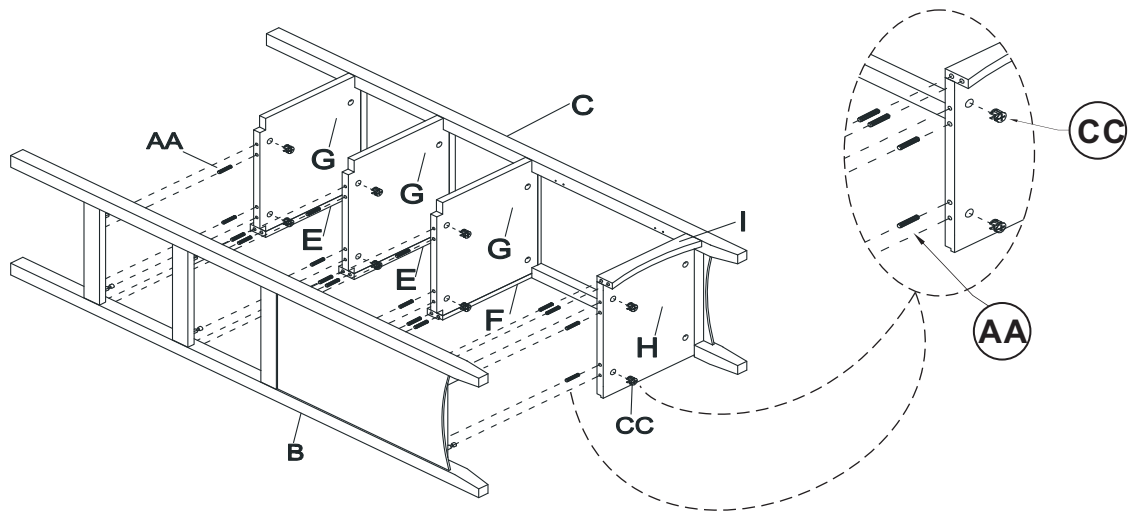

Assembling the Left Side Panel

1. Insert four wood dowels (AA) into dowel holes on the rear bar (E) and insert six wood dowels (AA) into dowel holes on the shelves (G). Insert two wood dowels (AA) into dowel holes on the rear bar (F). Insert two wood dowels (AA) into dowel holes on the bottom shelf (H). Insert two wood dowels (AA) into dowel holes on the cross bar (I).
2. Attach the left side panel (B) to the shelves (G) and bottom shelf (H) by inserting eight cam locks (CC) into cam lock holes in the shelves (G) and bottom shelf (H). Rotate clockwise to secure cam bolts in place by using a Phillips screwdriver.

STEP 6

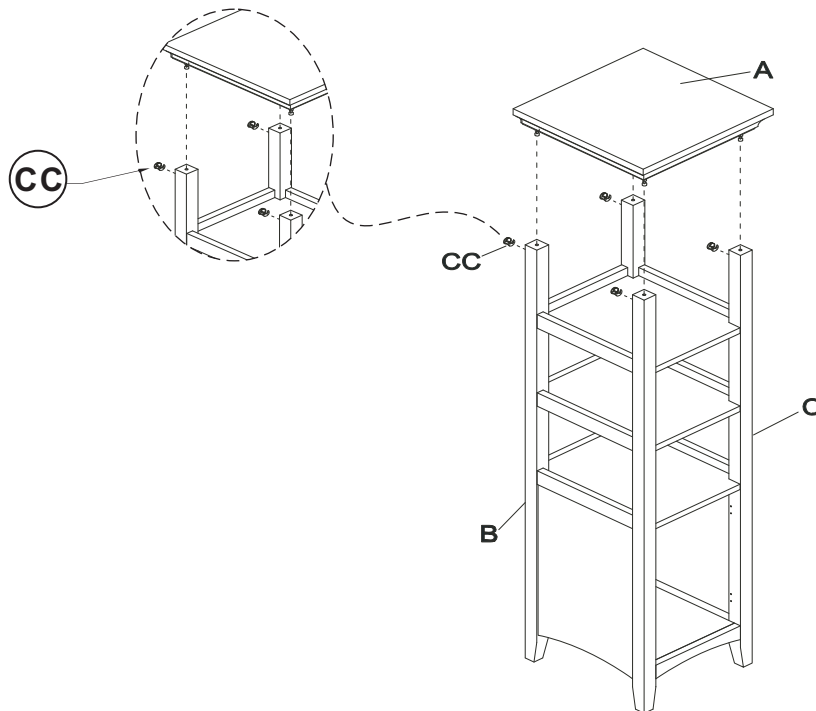

Assembling the Cabinet Top

1. Attach the cabinet top (A) to the left side panel (B) and right side panel (C) by inserting four cam locks (CC) into cam lock holes on the left side panel (B) and right side panel (C) and rotate clockwise to secure the cam bolts in place using a Phillips screwdriver.

STEP 7

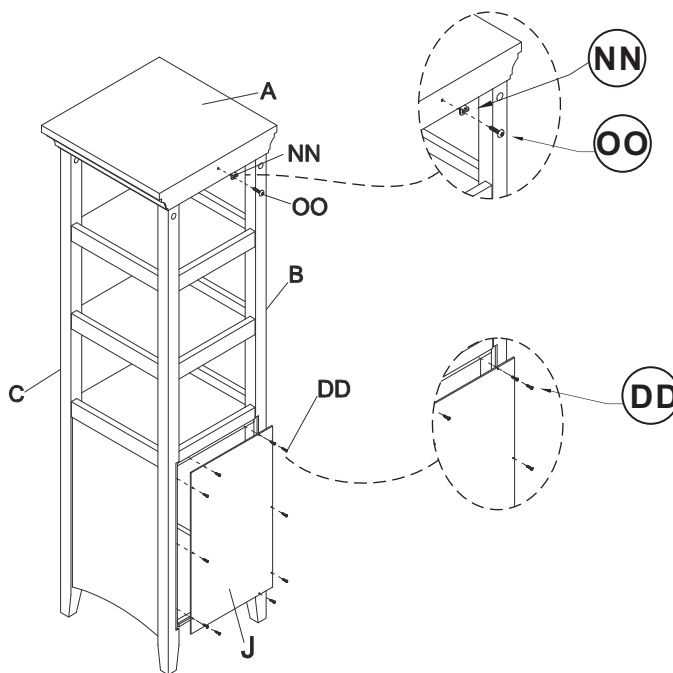

Assembling the Back Panel

1. Attach the back panel (J) to the left side panel (B), right side panel (C), bottom shelf (H) and bottom rear bar (F) by inserting fourteen screws (DD) through the holes on the back panel (J). Then tighten to the cabinet.
2. Attach the bracket (NN) to the center back of the cabinet top (A) by inserting a screw (OO) through the hole on the bracket (NN). Tighten to the cabinet top (A) using a Phillips screwdriver.

STEP 8

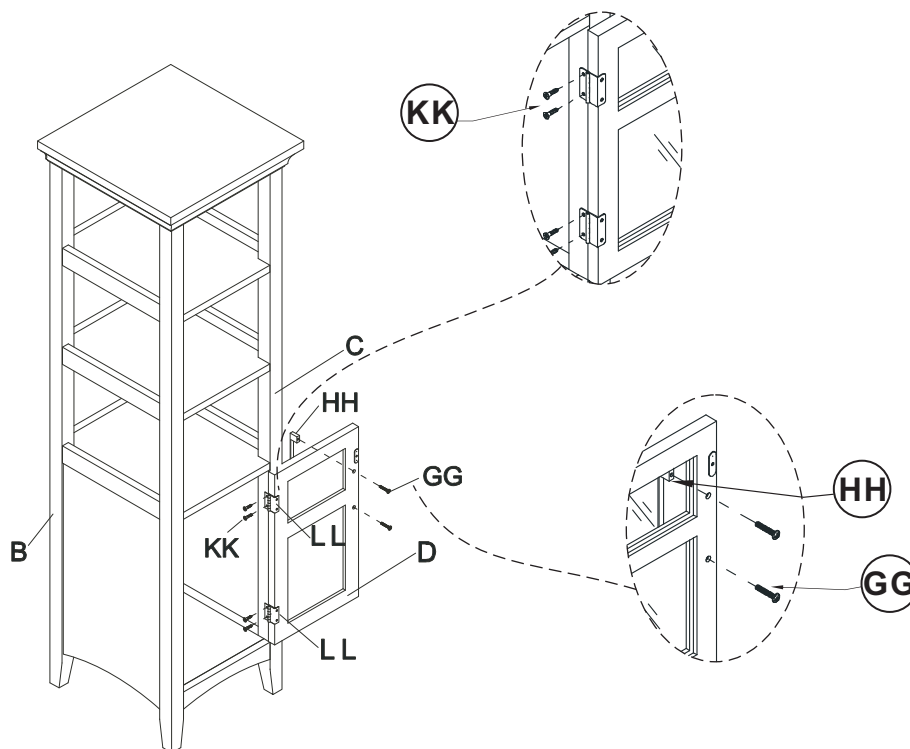

Assembling the Door

1. Attach the door (D) to the right side panel (C) by inserting four screws (KK) through the holes on hinge (LL) and tighten.
2. Attach handle (HH) to the door (D) with screws (GG).

STEP 9

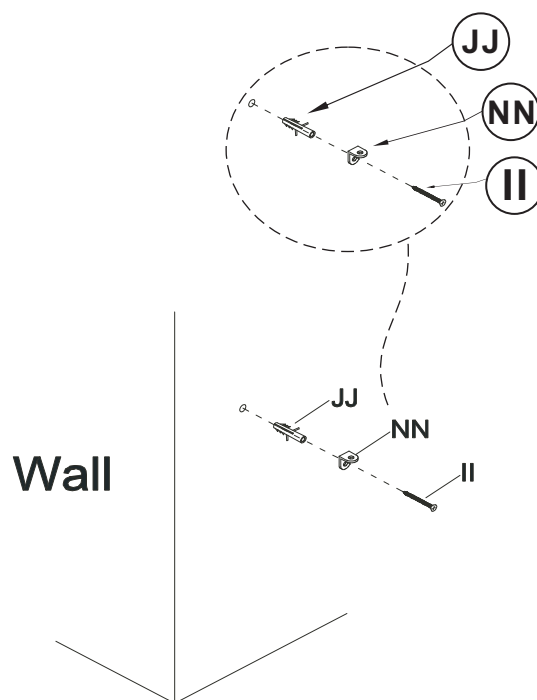

Assembling to the Wall

1. According to the position of the bracket (NN) assembled to the cabinet, drill a hole on the wall.
2. Insert one plastic anchor (JJ) into the hole on the wall then attach another bracket (NN) to the plastic anchor (JJ).
3. Insert one screw (II) through the bracket (NN) and tighten to the plastic anchor (JJ).

STEP 10

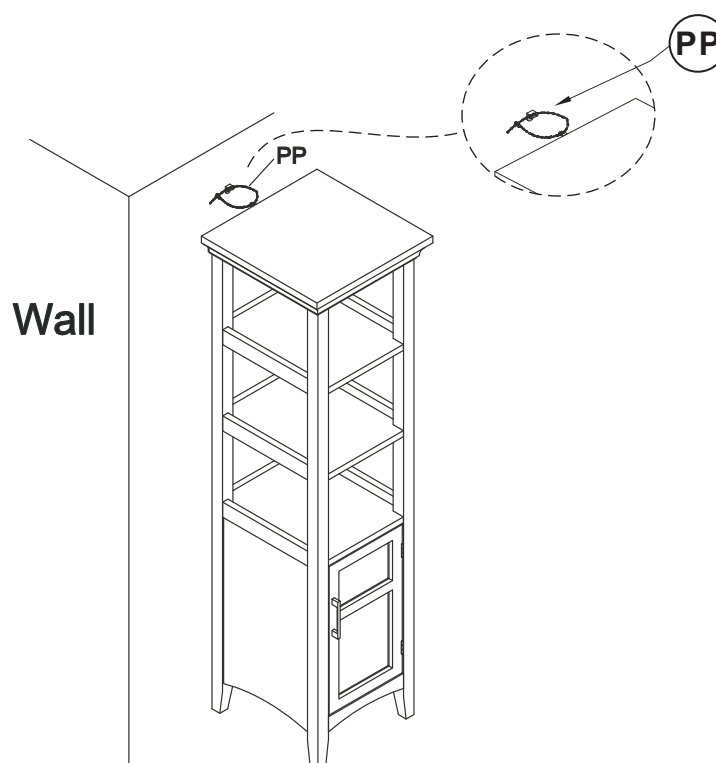

Fixing the Cable

1. Place the cabinet against the wall.
2. Insert the cable (PP) through the bracket (NN) on the cabinet, then through the other bracket (NN) on the wall. Fasten the cable (PP) to affix the two brackets (NN) firmly.



WARRANTY

Thank you for purchasing a **Simpli Home – Wyndenhall – Brooklyn + Max** product. These products have been made to demanding, high-quality standards and are guaranteed for domestic use against manufacturing faults for a period of 12 months from the date of purchase. This warranty does not affect your statutory rights.

In case of any malfunction of your product (failure, missing parts, etc.) please contact us at our toll free service line at 1-866-518-0120 ext. 262 from 9 am to 4 pm, Monday to Friday, Eastern Standard Time or by email at [simpli-home.com/customer-support](https://www.simpli-home.com/customer-support).

We reserve the right to repair or replace the defective product, at its discretion.

This product is guaranteed for 12 months if used for normal purposes. Any warranty is invalid if the product has been overloaded or subject to neglect, improper use or an attempted repair by other than an authorized agent. Heavy-duty or daily professional/commercial usage are not guaranteed.

Due to continuous product improvement, we reserve the right to change the product specifications without prior notice.



Question, problems, missing parts?

Before returning your product
please email Customer Support at
simpli-home.com/customer-support

or call

Customer Support at 1-866-518-0120 ext. 262
Monday to Friday between 9 am – 4 pm EST

For more information visit us on our website
www.simpli-home.com

Like us on facebook
www.facebook.com/simplihomefurnishings