

# DURAPAN™

U.S. PATENT NO. 5,452,739

# MODEL: 98

## WASHING MACHINE PAN

Made from extra-tough Durastone™



**ROUGH IN FOR :**  
**1" DWV (SOLVENT WELD) DRAIN**

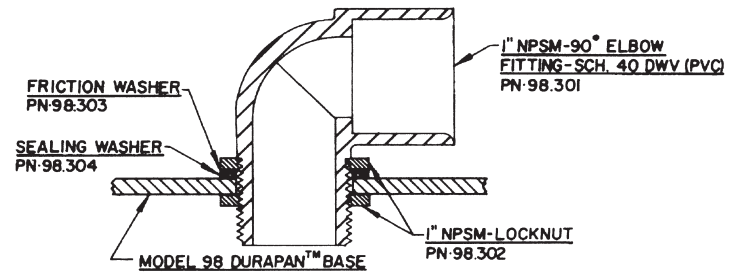
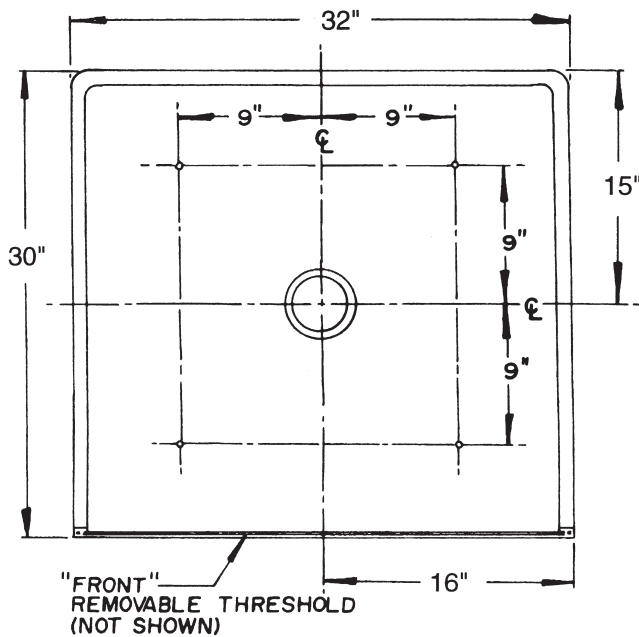

### SECTIONAL VIEW (TOP)

FOR REPLACEMENT SIDE OUTLET DRAIN  
ASSEMBLY - COMPLETE, ORDER: PART NO. 98.300A

**DOES NOT REQUIRE ALTERING SUB-FLOOR TO INSTALL**

### INSTALLATION:

1. Check **DURAPAN™** carefully making sure it is not damaged. Refer to the "rough-in" drawing and determine location of base on floor.
2. Determine desired location of 1" DWV Drain Fitting and drill the required 1-3/8" dia. mounting hole using the provided template as a guide (**FIG. A**). (**NOTE:** We recommend using a photocopy of the template and saving the original for your records.) Drill from the inside!
3. Screw locknut onto threaded end of drain fitting as far as possible by hand, then, use a wrench to tighten firmly. Assemble Drain Fitting to **DURAPAN™** as shown in the sectional view using all provided washers.
4. You will notice that there are four (4) countersunk holes in the floor area for securing **DURAPAN™** to sub-floor if desired. Using a 1/4" (inch) dia. drill bit, drill out each hole. Place **DURAPAN™** directly on sub-floor as a template and mark the four (4) previously drilled holes onto the sub-floor surface. Remove **DURAPAN™** and drill the appropriate sized holes as determined by the sub-floor composition:  
Wood: 3/16" (inch) dia. drill  
Cement: 3/8" (inch) dia. drill for anchors-supplied  
Reposition **DURAPAN™**, align screw holes (apply a dab of silicone sealant into each hole) and secure with #14x1-1/4" Flat Hd. Screws - wipe away any excess sealant that seeps out from under screw head.
5. Make Drain Fitting connection in full compliance with local code requirements.
6. The removable Threshold is secured with two (2) #10-24x1/2" Pan Hd. Screws. Remove screws and Threshold and set "wash machine" in place. Reinstall Threshold.

**E.L. MUSTEE & SONS, INC.**

5431 West 164th Street • Brook Park, Ohio 44142

SI-182 (10•05)

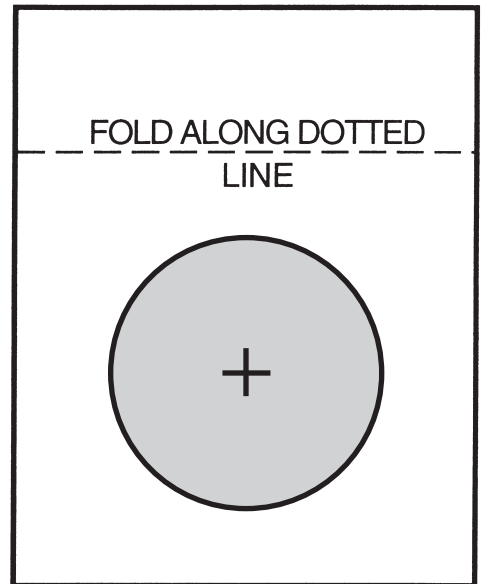
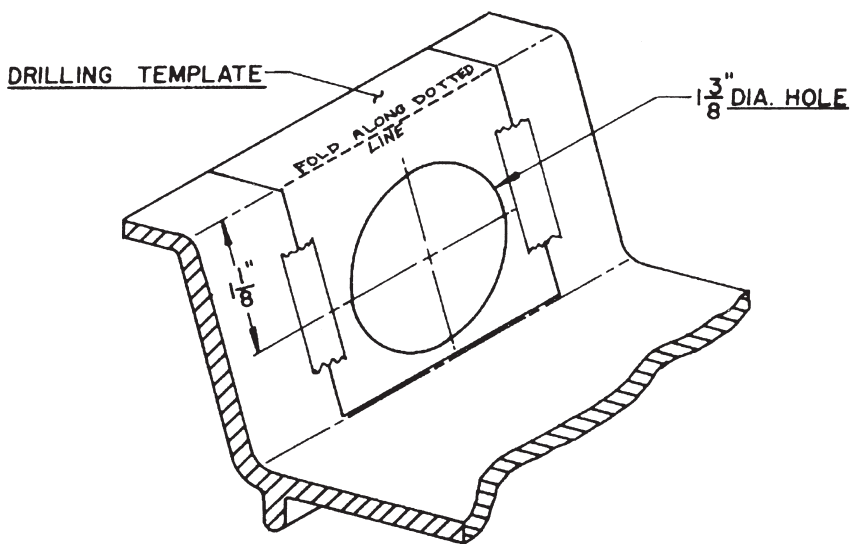

**FIG. A**

**PARTS ILLUSTRATION:**

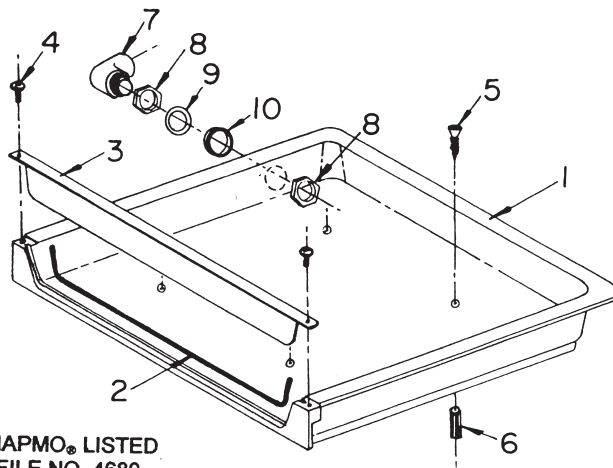

UPC  
IAPMO® LISTED  
FILE NO. 4680

**CARE AND CLEANING**

The surface of your **DURAPAN™** Wash Machine/Overflow Base may be cleaned with a mild soap solution in warm water using a soft cloth. For stubborn stains use "Soft-Scrub" by Clorox or Lysol "Tub & Tile Cleaner" or a powdered detergent such as "Spic-n-Span". Never use abrasive scouring powder or steel wool pads as they will dull and scratch the surface. A periodic coating of a silicone based marine polish will help retain the fine finish.

**PARTS LIST**

KEY NO.	PART NO.	DESCRIPTION
1	98.102	<b>DURAPAN™</b> OVERFLOW BASE
2	99.401	THRESHOLD SEAL
3	99.201	THRESHOLD
4	99.801	#10-24 X 1/2" THRESHOLD SCREW - 2 REQUIRED
5	99.803	#14-1 1/4" FLAT HD. SCREW - 4 REQUIRED
6	17.806	ANCHOR, MOLDED - 4 REQUIRED
7	98.301	90° ELBOW FITTING
8	98.302	1" LOCKNUT - 2 REQUIRED
9	98.303	WASHER, FRICTION
10	98.304	WASHER, SEALING - 1/8" THICK

**E.L. MUSTEE & SONS, INC.**

5431 West 164th Street • Brook Park, Ohio 44142

SI-182 (10•05)