

Model XAG04Z Parts List

A = Standard Equipment

O = Circuit Diagram

Item#	Part#	Description	Q'ty	Unit	
001-2	629176-0	STATOR COMPLETE	1		
002	211021-9	BALL BEARING 607LLB	1	PC.	
003-1	519378-5	ROTOR ASS'Y	1		
	D10	INC. 2			
004	319214-3	GEAR HOUSING COVER	1		
005	213445-5	O-RING 26	1	PC.	
006	210042-8	BALL BEARING 629LLB	1	PC.	
007	227541-3	SPIRAL BEVEL GEAR 10	1	PC.	
008	252186-8	HEX. NUT M6	1	PC.	
009	417771-6	PIN CAP	1	PC.	
010	233072-2	COMPRESSION SPRING 8	1	PC.	
011	266361-0	TAPPING SCREW 4X30	4	PC.	
012	213960-9	O RING 5	1	PC.	
013	256546-6	SHOULDER PIN 4	1	PC.	
014	319213-5	GEAR HOUSING	1		
015	263002-9	RUBBER PIN 4	1	PC.	
016	210033-9	BALL BEARING 696ZZ	1	PC.	
017	233950-6	RING SPRING 11	1	PC.	
018	227641-9	SPIRAL BEVEL GEAR 37	1		
019	962151-6	RETAINING RING R-32	1	PC.	
020	211129-9	BALL BEARING 6201DDW	1	PC.	
021	267113-2	FLAT WASHER 12	1	PC.	
022	213622-9	O RING 45	1	PC.	
023	318331-6	BEARING BOX	1	PC.	
024	911121-2	PAN HEAD SCREW M4X14	4	PC.	
025	345464-4	LABYRINTH RING	1	PC.	
026	324955-8	SPINDLE A	1	PC.	
027-1	126687-1	TOOLLESS WHEEL COVER 125AKL AS	1		
	C10	213009-5	O RING 4	1	PC.
	C20	265180-1	PAN HEAD SCREW M5X16	1	PC.
028	224399-1	INNER FLANGE 45	1	PC.	
029	193465-4	LOCK NUT 5/8-45	1	PC.	
030	850J44-8	XAG04 NAME PLATE	1		
031	266326-2	TAPPING SCREW 4X18	5	PC.	
032	455450-8	DUST COVER R	1		
033	187998-9	MOTOR HOUSING SET	1	PC.	
	C10	263005-3	RUBBER PIN 6	2	PC.
	D10	INC. 41			
034	455447-7	SWITCH KNOB	1		
035	455446-9	SWITCH LEVER	1		
036	455448-5	LEVER	1		
037	231679-8	TORSION SPRING 2	1		
038	268330-7	PIN 2	1		
039	142901-7	INDICATOR PANEL COMPLETE	1		
040	650579-7	SWITCH 1246.3223	1	PC.	
041	187998-9	MOTOR HOUSING SET	1	PC.	
	C10	263005-3	RUBBER PIN 6	2	PC.
	D10	INC. 33			
042	455449-3	DUST COVER L	1		

043	643899-6	TERMINAL	1 PC.
046	850J48-0	XAG04 SERIAL NO. LABEL	1
A01-1	126686-3	WHEEL COVER 125CKL ASSEMBLY	1
C10	213009-5	O RING 4	1 PC.
C20	265180-1	PAN HEAD SCREW M5X16	1 PC.
A02	158237-4	GRIP 36 COMPLETE	1 PC.
A03	782424-9	LOCK NUT WRENCH 28	1 PC.
A04	A-95962	INOX GRINDING WHEEL 125MM	1 PC.
A05-1	B-46165	THIN CUTTING 125X0.8 MM	1 PC.
E01	805C42-5	CAUTION LABEL	1

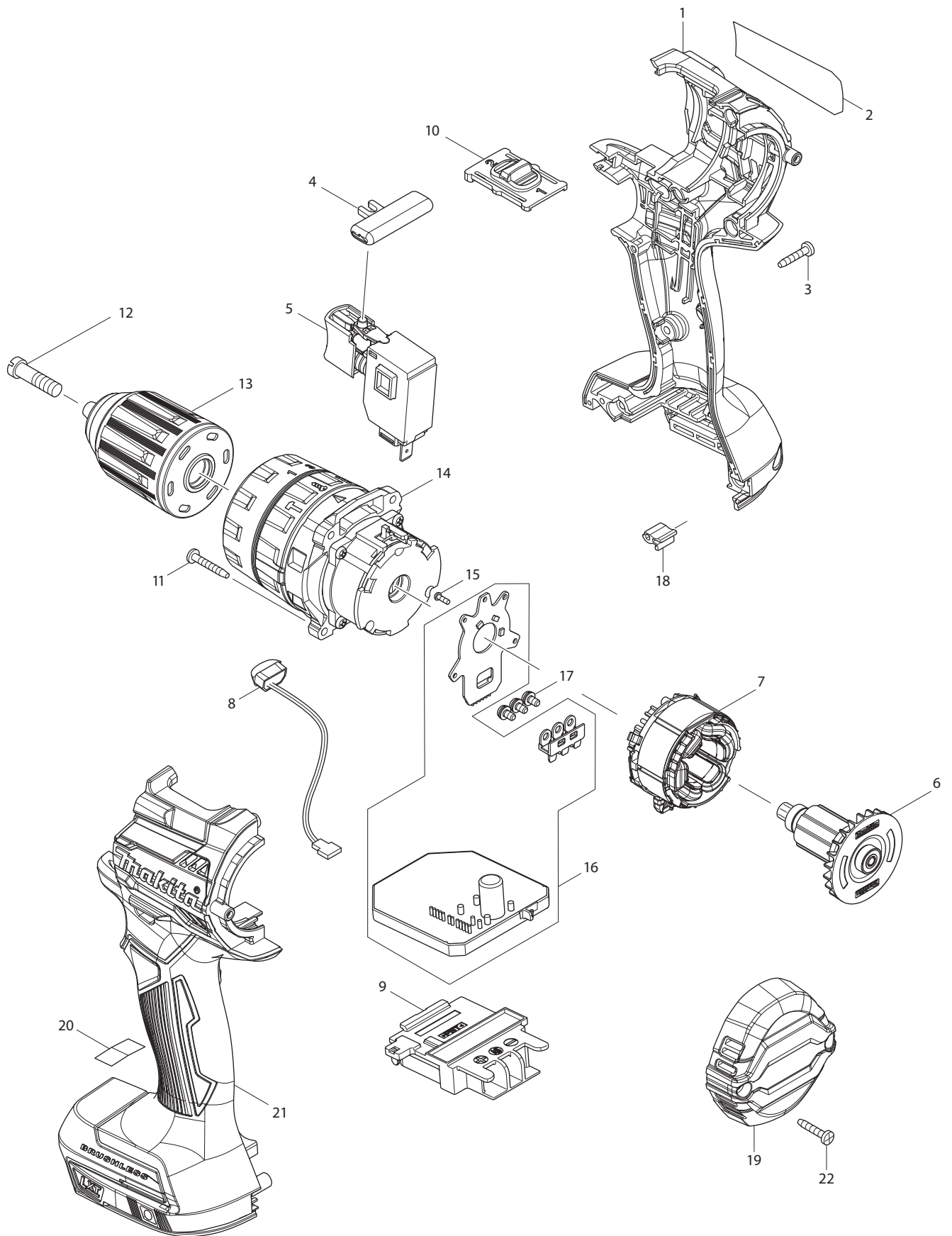

Model XPH12 M/R/Z Parts List

A = Standard Equipment

O = Circuit Diagram

Item#	Part#	Description	Q'ty	Unit
001	183E71-3	HOUSING SET	1	
	C10 263005-3	RUBBER PIN 6	2	PC.
	C20 252126-6	HEX. LOCKING NUT M4-7	2	PC.
	D10	INC. 21		
002	852L95-9	XPH12 NAME PLATE	1	
003	266429-2	TAPPING SCREW 3X16	7	PC.
004	419041-9	F/R CHANGE LEVER	1	PC.
005	650710-5	SWITCH C3JW-4B	1	
006	619406-7	ROTOR	1	
007	629225-3	STATOR	1	
008	620549-0	LED CIRCUIT	1	
009	643874-2	TERMINAL	1	PC.
010	123738-1	SPEED CHANGE LEVER ASSEMBLY	1	
	C10 233438-6	COMPRESSION SPRING 4	2	PC.
011	251497-8	TAPPING SCREW 3X20	4	
012	251468-5	- FLAT HEAD SCREW M6X22	1	PC.
013	766027-7	KEYLESS DRILL CHUCK 13	1	
014	123736-5	GEAR ASSEMBLY	1	
015	266490-9	TAPPING SCREW PT 2X6	3	PC.
016	620548-2	CONTROLLER	1	
017	652069-6	FLAT HEAD SCREW M3X6	3	PC.
018	424517-3	CUSHION	1	PC.
019	456966-6	REAR COVER	1	
020	809U04-3	CAUTION LABEL	1	
021	183E71-3	HOUSING SET	1	
	C10 263005-3	RUBBER PIN 6	2	PC.
	C20 252126-6	HEX. LOCKING NUT M4-7	2	PC.
	D10	INC. 1		
022	266429-2	TAPPING SCREW 3X16	2	PC.
A01	251314-2	+ SCREW M4X12	1	PC.
A02	346449-3	HOOK	1	PC.
A04	158597-4	PLASTIC CASE COMPLETE	1	PC. (XPH12M/R)
	C10 417724-5	LATCH	2	PC. (XPH12M/R)
A05	450128-8	BATTERY COVER	1	PC. (XPH12M/R)
A06	***DC18RC	DC18RC FAST CHARGER	1	PC. (XPH12M/R)
	D10	COMPO-PARTS		
A07	BL1840B	BATTERY BL1840B SET	2	(XPH12M)
	BL1820B	BATTERY BL1820B SET	2	(XPH12R)

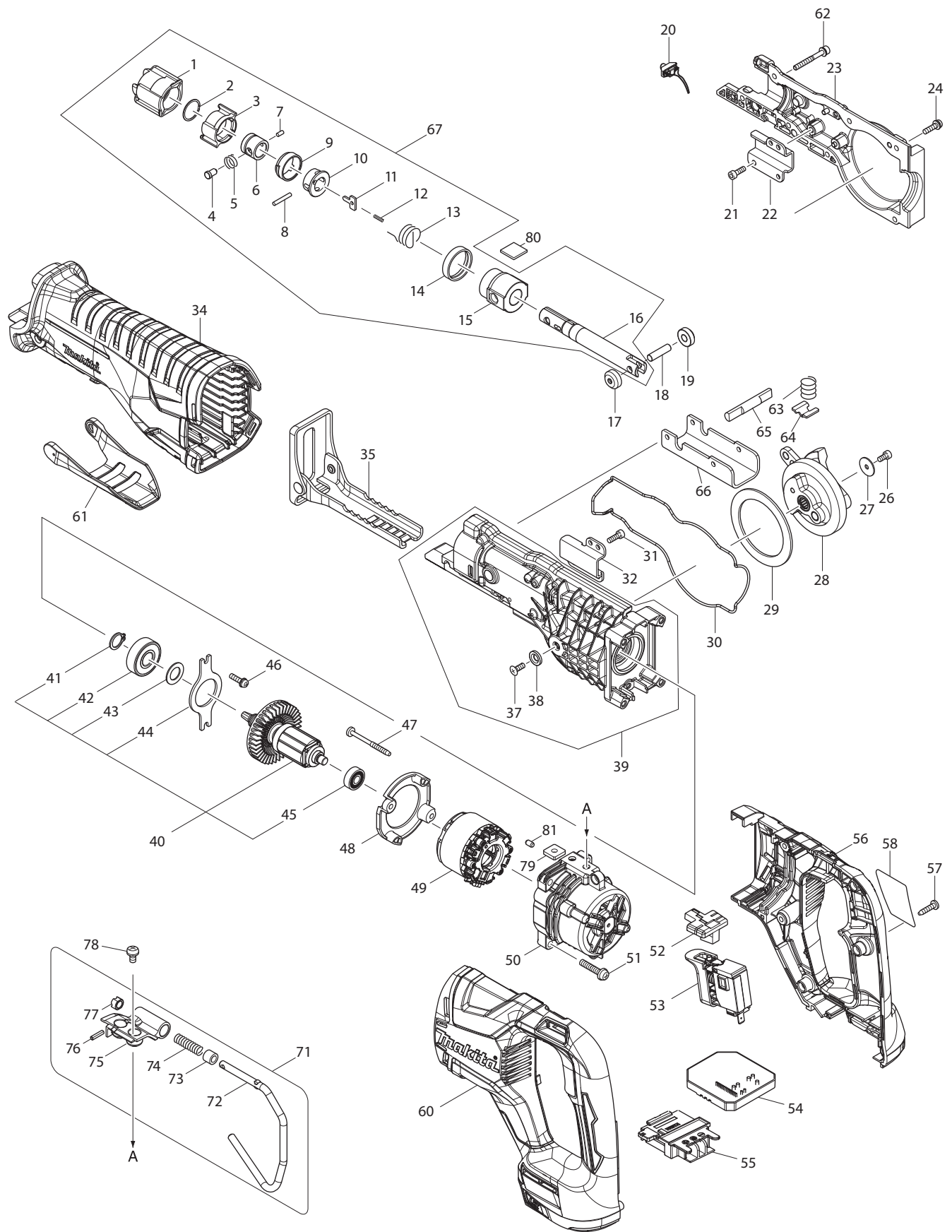

Model XRJ05M/Z Parts List

A = Standard Equipment

O = Circuit Diagram

Item#	Part#	Description	Q'ty Unit
001	424763-8	PROTECTOR	1
002	257952-8	RETAINING RING (EXT) 18	1 PC.
003	310662-9	DRIVING SLEEVE	1
004	256569-4	SHOULDER PIN 5	1
005	234381-2	COMPRESSION SPRING 6	1
006	331720-8	GUIDE SLEEVE	1 PC.
007	268094-3	PIN 3	1 PC.
008	256158-5	PIN 3	1 PC.
009	417791-0	DRIVING SLEEVE GUIDE	1 PC.
010	418311-3	SLEEVE	1 PC.
011	345214-7	PUSH PLATE	1 PC.
012	233025-1	COMPRESSION SPRING 2	1 PC.
013	231687-9	TORSION SPRING 17	1 PC.
014	424762-0	RUBBER RING	1
015	143365-8	SLIDER GUIDE COMPLETE	1 PC.
	C10 213151-2	OIL SEAL 14	1 PC.
	C20 213174-0	X RING 14	1 PC.
016	161376-1	SLIDER	1
017	310663-7	ROLLER	1
018	268341-2	PIN 6	1
019	310663-7	ROLLER	1
020	620434-7	LED CIRCUIT	1 PC.
021	922117-8	HEX. SOCKET HEAD BOLT M4X12	2 PC.
022	346936-2	ROD GUIDE R	1
023	143362-4	GEAR HOUSING R COMPLETE	1 PC.
024	911128-8	PAN HEAD SCREW M4X16	5 PC.
026	922107-1	HEX. SOCKET HEAD BOLT M4X8	1 PC.
027	267491-0	FLAT WASHER 4	1
028	143359-3	GEAR COMPLETE	1 PC.
029	267490-2	FLAT WASHER 54	1
030	424764-6	SEAL RING	1
031	922117-8	HEX. SOCKET HEAD BOLT M4X12	2 PC.
032	346935-4	ROD GUIDE L	1
034	424765-4	INSULATION COVER	1
035	161374-5	SHOE	1
037	912112-6	COUNTERSUNK HEAD SCREW M4X10	1 PC.
038	253825-3	FLAT WASHER 6	1 PC.
039	123509-6	GEAR HOUSING L ASSEMBLY	1 PC.
	D10	INC. 37,38	
040-1	519418-9	ROTOR ASS'Y	1
	D10	INC. 41-45	
041	961052-5	RETAINING RING S-12	1 PC.
042	211129-9	BALL BEARING 6201DDW	1 PC.
043	253744-3	FLAT WASHER 12	1 PC.
044	285740-3	BEARING RETAINER 66	1
045	210062-2	BALL BEARING 607ZZ	1 PC.
046	911128-8	PAN HEAD SCREW M4X16	2 PC.
047	266069-6	TAPPING SCREW 4X45	2 PC.
048	456178-1	BAFFLE PLATE	1

049	629179-4	STATOR	1	
050	456179-9	MOTOR HOUSING	1	
051	911243-8	PAN HEAD SCREW M5X25	4 PC.	
052	456177-3	CHANGE BUTTON	1	
053	650759-5	SWITCH C3JW-6B-2	1	
054	620432-1	CONTROLLER A	1 PC.	
055	643899-6	TERMINAL	1 PC.	
056	183C47-8	HANDLE SET	1	
	C10 263005-3	RUBBER PIN 6	2 PC.	
	D10	INC. 60		
057	266326-2	TAPPING SCREW 4X18	6 PC.	
058	851P11-2	XRJ05 NAME PLATE	1	
059	807Y38-4	CAUTION LABEL	1	
060	183C47-8	HANDLE SET	1	
	C10 263005-3	RUBBER PIN 6	2 PC.	
	D10	INC. 56		
061	456176-5	LOCK LEVER	1	
062	266979-7	HEX.SOCKET HEAD BOLT M4X35 WR	2	
063	231231-2	COMPRESSION SPRING 12	1 PC.	
064	346938-8	SHOE LOCK PLATE	1	
065	326599-0	LOCK PIN	1	
066	346937-0	SHOE GUIDE PLATE	1	
067	123510-1	SLIDER ASSEMBLY	1 PC.	
	D10	INC. 1-16		
071	123455-3	HOOK ASSEMBLY	1 PC.	
	D10	INC. 72-77		
072	281223-1	HOOK	1	
073	262561-0	SLEEVE 6	1 PC.	
074	233455-6	COMPRESSION SPRING 7	1 PC.	
075	319344-0	JOINT	1	
076	951057-3	SPRING PIN 3-12	1 PC.	
077	310661-1	LOCK SLEEVE	1	
078	911206-4	PAN HEAD SCREW M5X10	2 PC.	
079	264002-2	SQUARE NUT M5	2 PC.	
080	424858-7	FELT 16X16	1 PC.	
081	263002-9	RUBBER PIN 4	1 PC.	
A01	194502-7	RECIPRO SAW BLADE SET	1 SET	
A03	821620-5	PLASTIC TOOL CASE	1	(XRJ05M)
	C10 162271-8	LATCH	2 PC.	(XRJ05M)
A05	450128-8	BATTERY COVER	1 PC.	(XRJ05M)
A06	***DC18RC	DC18RC FAST CHARGER	1 PC.	(XRJ05M)
	D10	COMPO-PARTS		
A07	BL1840B	BATTERY BL1840B SET (197268-8)	2	(XRJ05M)

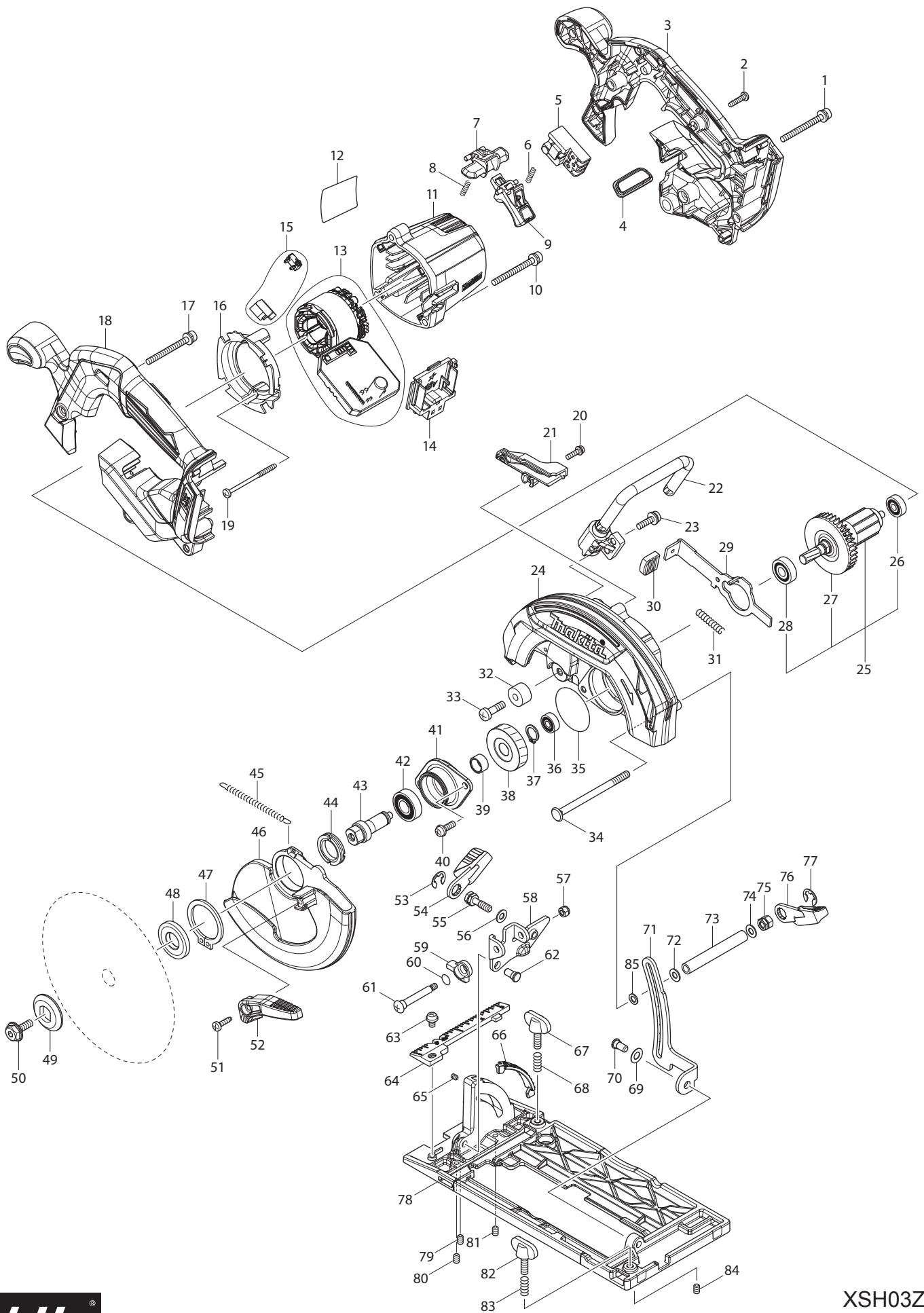

Model XSH03Z Parts List

A = Standard Equipment

O = Circuit Diagram

Item#	Part#	Description	Q'ty	Unit
001	911263-2	PAN HEAD SCREW M5X40	1	PC.
002	265995-6	TAPPING SCREW 4X18	7	PC.
003	183A13-3	HANDLE SET	1	
	C10 263005-3	RUBBER PIN 6	2	PC.
	C20 805E02-9	CAUTION LABEL	1	
	D10	INC. 18		
004	142948-1	INDICATION PLATE COMPLETE	1	
005	650734-1	SWITCH TG73BDS-2	1	
006	231469-9	COMPRESSION SPRING 4	1	PC.
007	419664-3	LOCK OFF LEVER	1	PC.
008	231469-9	COMPRESSION SPRING 4	1	PC.
009	455480-9	SWITCH LEVER	1	
010	911263-2	PAN HEAD SCREW M5X40	3	PC.
011	455437-0	MOTOR HOUSING	1	
012	850H70-5	XSH03 NAME PLATE	1	
013	632D90-5	STATOR UNIT	1	PC.
014	644808-8	TERMINAL	1	PC.
015	632D81-6	SWITCH UNIT	1	
016	455440-1	BAFFLE PLATE	1	
017	911263-2	PAN HEAD SCREW M5X40	1	PC.
018	183A13-3	HANDLE SET	1	
	C10 263005-3	RUBBER PIN 6	2	PC.
	C20 805E02-9	CAUTION LABEL	1	
	D10	INC. 3		
019	266091-3	TAPPING SCREW 4X50	2	PC.
020	911128-8	PAN HEAD SCREW M4X16	1	PC.
021	455483-3	DUCT	1	
022	123269-0	HOOK ASSEMBLY	1	PC.
023	911233-1	PAN HEAD SCREW M5X20	2	PC.
024	142942-3	BLADE CASE COMPLATE	1	
	C10 213953-6	O RING 24	1	PC.
025	519359-9	ROTOR ASS'Y	1	PC.
	D10	INC. 26-28		
026	210022-4	BALL BEARING 626DDW	1	PC.
027	240045-8	FAN 55	1	PC.
028	210051-7	BALL BEARING 609LLB	1	PC.
029	346837-4	SHAFT LOCK	1	
030	286275-7	CAP	1	PC.
031	233117-6	COMPRESSION SPRING 6	1	PC.
032	262552-1	RUBBER SLEEVE 6	1	PC.
033	251247-1	+ PAN HEAD SCREW M6X20	1	PC.
034	266194-3	FLAT HEAD SCREW M6X90	1	PC.
035	213565-5	O RING 42	1	PC.
036	210028-2	BALL BEARING 606ZZ	1	PC.
037	961052-5	RETAINING RING S-12	1	PC.
038	227794-4	HELICAL GEAR 50	1	
039	257349-1	SLEEVE 12	1	
040	911223-4	PAN HEAD SCREW M5X16	2	PC.
041	319212-7	BEARING BOX	1	
042	211131-2	BALL BEARING 6001DDW	1	PC.

043	326459-6	SPINDLE	1
044	285845-9	BEARING RETAINER 19-29	1 PC.
045	231878-2	TENSION SPRING 4	1 PC.
046	319211-9	SAFETY COVER	1
047	961152-1	RETAINING RING (EXT) S-34	1 PC.
048	224411-7	INNER FLANGE 35	1 PC.
049	224409-4	OUTER FLANGE 35	1 PC.
050	266924-2	HEX. SOCKET HEX. BOLT M6X18	1
051	266034-5	TAPPING SCREW CT 4X16	1 PC.
052	272282-6	LEVER 60	1
053	257982-9	BOW STOP RING E-8	1 PC.
054	272272-9	LEVER 45	1 PC.
055	266735-5	HEX.BOLT M6X20	1 PC.
056	941151-9	FLAT WASHER 6	1 PC.
057	252103-8	HEX. LOCK NUT M5-8	1 PC.
058	346836-6	ANGULAR GUIDE	1
059	317986-4	STOPPER	1 PC.
060	213062-1	O RING 9	1 PC.
061	265084-7	+ TRUSS HEAD SCREW M5	1 PC.
062	256480-0	SHOULDER PIN 6-7	1 PC.
063	911203-0	PAN HEAD SCREW M5X8	1 PC.
064	455515-6	TOP GUIDE	1
065	266318-1	H.S.SET SCREW(FLAT POINT)M4X6	2 PC.
066	455517-2	BEVEL GUIDE	1
067	251896-4	SCREW M5X20	1 PC.
068	231007-7	COMPRESSION SPRING 6	1 PC.
069	253058-0	FLAT WASHER 7	1 PC.
070	256511-5	SHOULDER PIN 6-7	1 PC.
071	346835-8	DEPTH GUIDE	1
072	941151-9	FLAT WASHER 6	1 PC.
073	332126-3	PIPE 6	1
074	941151-9	FLAT WASHER 6	1 PC.
075	264103-6	HEX. NUT M6	1
076	272272-9	LEVER 45	1 PC.
077	257982-9	BOW STOP RING E-8	1 PC.
078	319210-1	BASE	1
079	266436-5	H.S.SET SCREW(FLAT POINT)M5X8	1
080	266436-5	H.S.SET SCREW(FLAT POINT)M5X8	1
081	266436-5	H.S.SET SCREW(FLAT POINT)M5X8	1
082	251896-4	SCREW M5X20	1 PC.
083	231007-7	COMPRESSION SPRING 6	1 PC.
084	266436-5	H.S.SET SCREW(FLAT POINT)M5X8	1
085	253077-6	FLAT WASHER 6	1 PC.
A01	783203-8	HEX. WRENCH 5	1 PC.
A02	A-85092	T.C.T.SAW BLADE 165X24TX15.88	1 PC.
E01	805E03-7	CAUTION LABEL	1

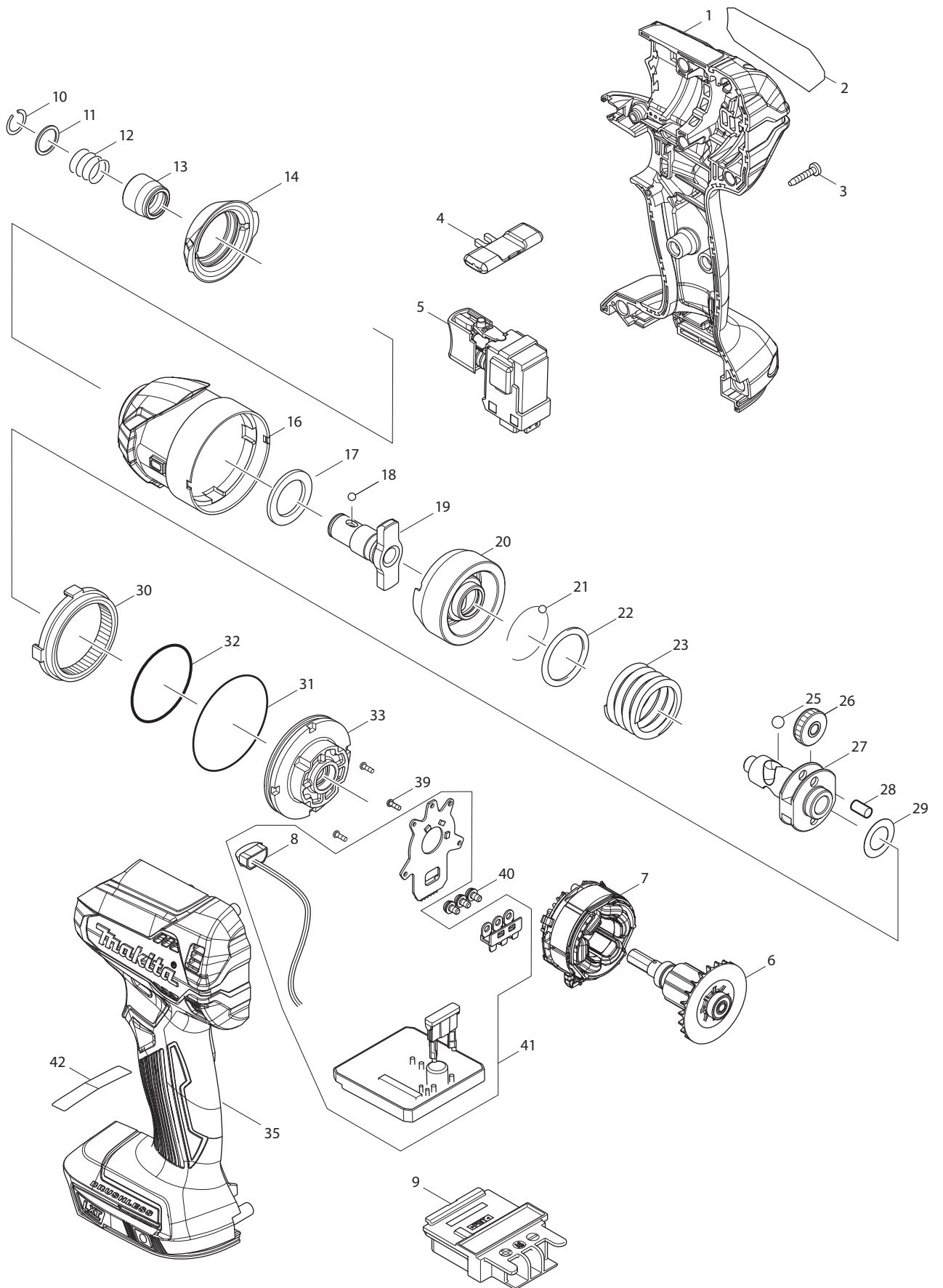

Model XDT13M/R/Z Parts List

A = Standard Equipment

O = Circuit Diagram

Item#	Part#	Description	Q'ty	Unit
001	183E34-9	HOUSING SET	1	
	C10 263005-3	RUBBER PIN 6	2	PC.
	C20 252126-6	HEX. LOCKING NUT M4-7	2	PC.
	D10	INC. 35		
002	852K78-3	XDT13 NAME PLATE	1	
003	266429-2	TAPPING SCREW 3X16	9	PC.
004	455053-8	F/R CHANGE LEVER	1	PC.
005	143975-1	SWITCH COMPLETE	1	
006	619404-1	ROTOR	1	
007	629224-5	STATOR	1	
008	620557-1	LED CIRCUIT	1	
009	643860-3	TERMINAL	1	PC.
010	231951-8	RING SPRING 11	1	PC.
011	267085-1	FLAT WASHER 12	1	PC.
012	233005-7	COMPRESSION SPRING 13	1	PC.
013	326068-1	BIT SLEEVE	1	PC.
014	424888-8	BUMPER	1	
016	143957-3	HAMMER CASE COMPLETE	1	
017	261151-6	NYLON WASHER 19	1	PC.
018	216040-0	STEEL BALL 3.5	2	PC.
019	326563-1	ANVIL M	1	
020	326564-9	HAMMER	1	
021	216040-0	STEEL BALL 3.5	24	PC.
022	267175-0	FLAT WASHER 24	1	PC.
023	234251-5	COMPRESSION SPRING 25	1	PC.
025	216041-8	STEEL BALL 5.6	2	
026	227362-3	SPUR GEAR 22	2	PC.
027	326562-3	SPINDLE	1	
028	256253-1	PIN 5	2	PC.
029	253314-8	THIN WASHER 15	1	PC.
030	227378-8	INTERNAL GEAR 51	1	
031	213606-7	O RING 48	1	PC.
032	213507-9	O RING 40	1	PC.
033	143958-1	BEARING BOX COMPLETE	1	
035	183E34-9	HOUSING SET	1	
	C10 263005-3	RUBBER PIN 6	2	PC.
	C20 252126-6	HEX. LOCKING NUT M4-7	2	PC.
	D10	INC. 1		
039	266490-9	TAPPING SCREW PT 2X6	3	PC.
040	652069-6	FLAT HEAD SCREW M3X6	3	PC.
041	620556-3	CONTROLLER	1	
	D10	INC. 8		
042	809R90-6	CAUTION LABEL	1	
A01	266622-8	+ TRUSS HEAD SCREW M4X12	1	PC.
A02	346449-3	HOOK	1	PC.
A03	450128-8	BATTERY COVER	1	PC. (XDT13M/R)
A04	***DC18RC	DC18RC FAST CHARGER	1	PC. (XDT13M/R)
	D10	COMPO-PARTS		
A05	BL1840B	BATTERY BL1840B SET	2	(XDT13M)

	BL1820B	BATTERY BL1820B SET	2	(XDT13R)
A06	141856-3	PLASTIC CARRYING CASE COMPLETE	1	PC. (XDT13M/R)
C10	162302-3	LATCH	2	PC. (XDT13M/R)