

REVISIONS				
ZONE	REV.	DESCRIPTION	DATE	APPROVED

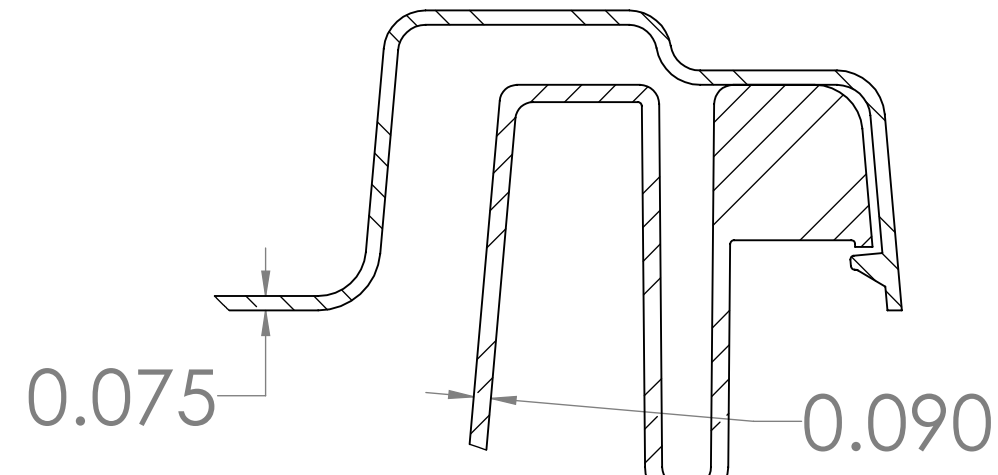

SECTION A-A
SCALE 1 : 1

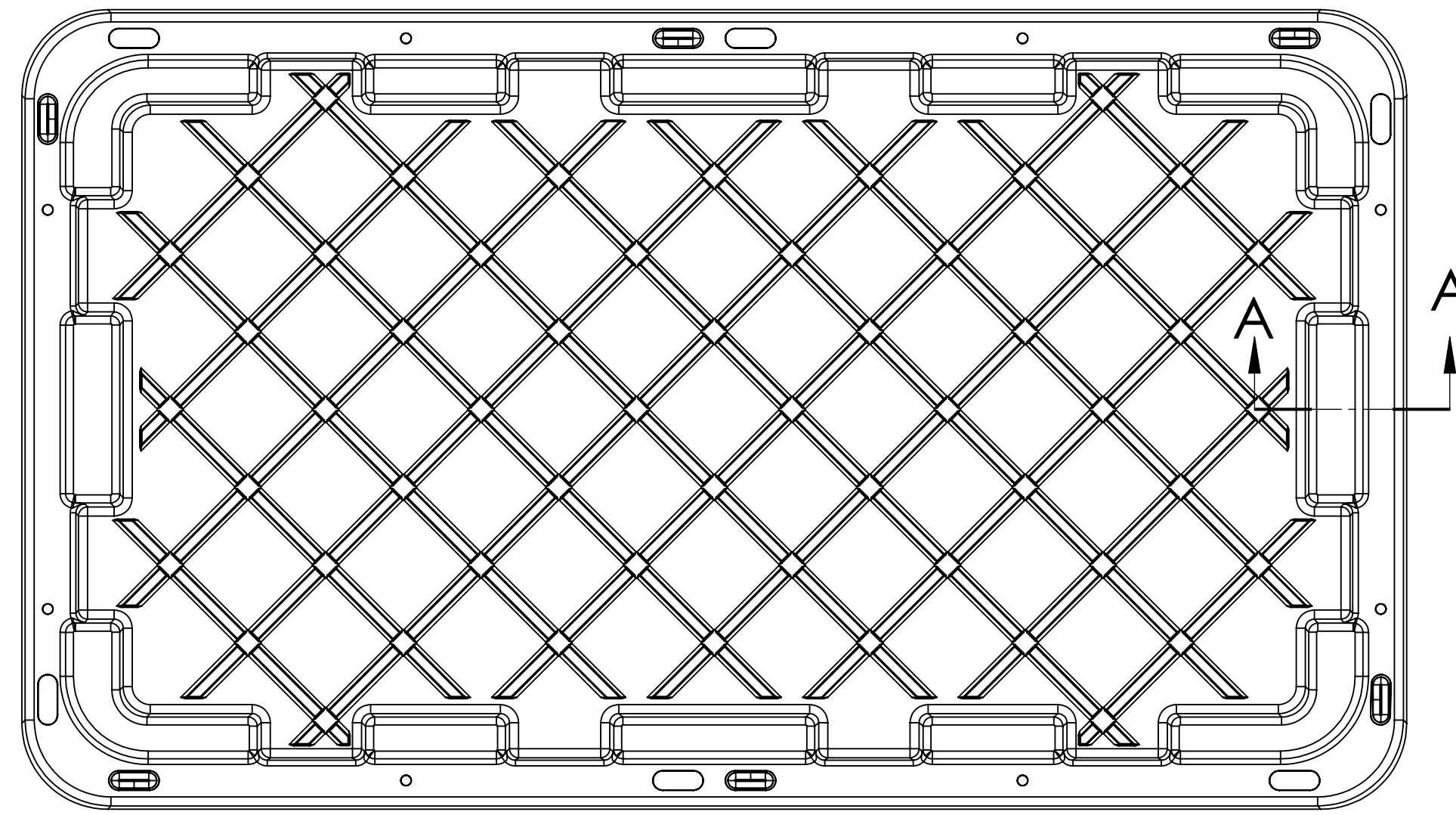
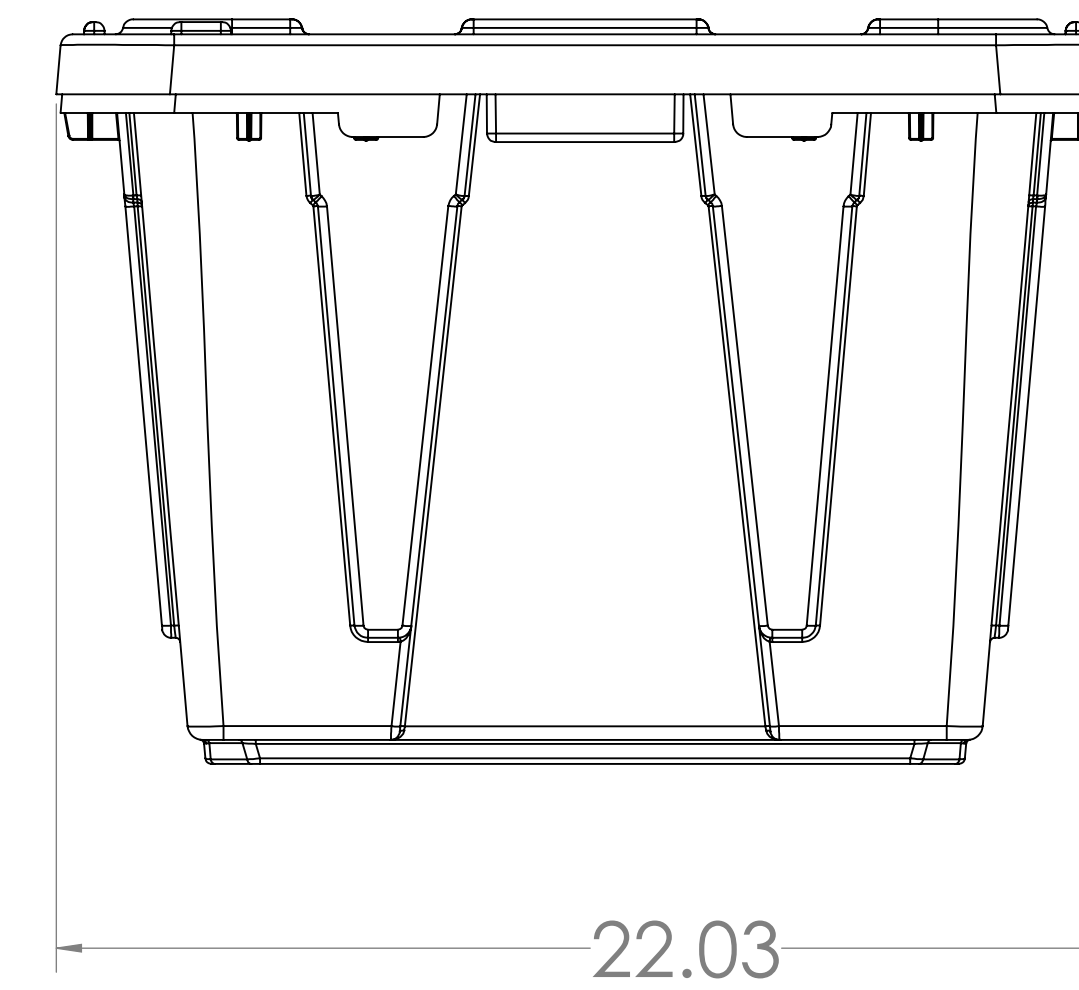
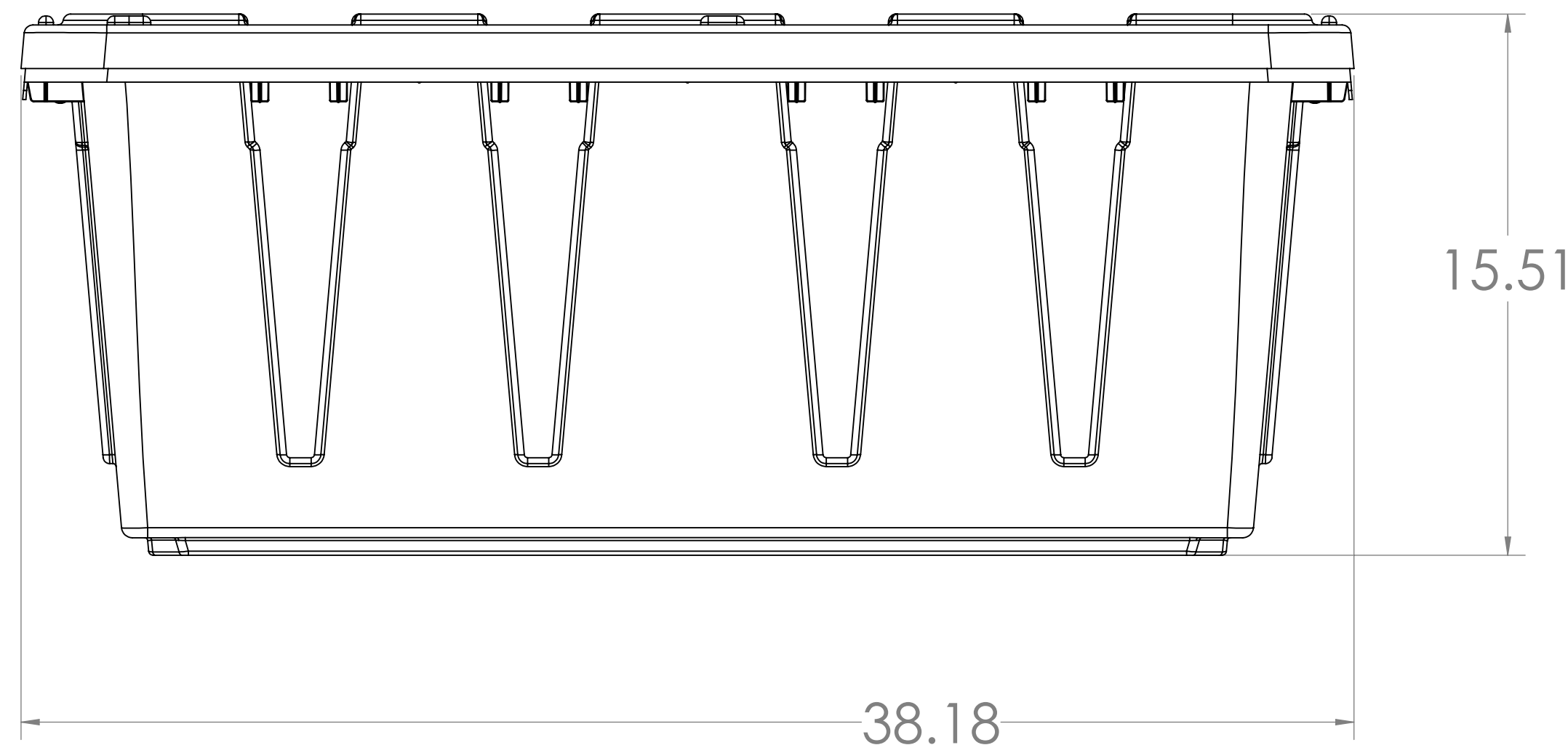
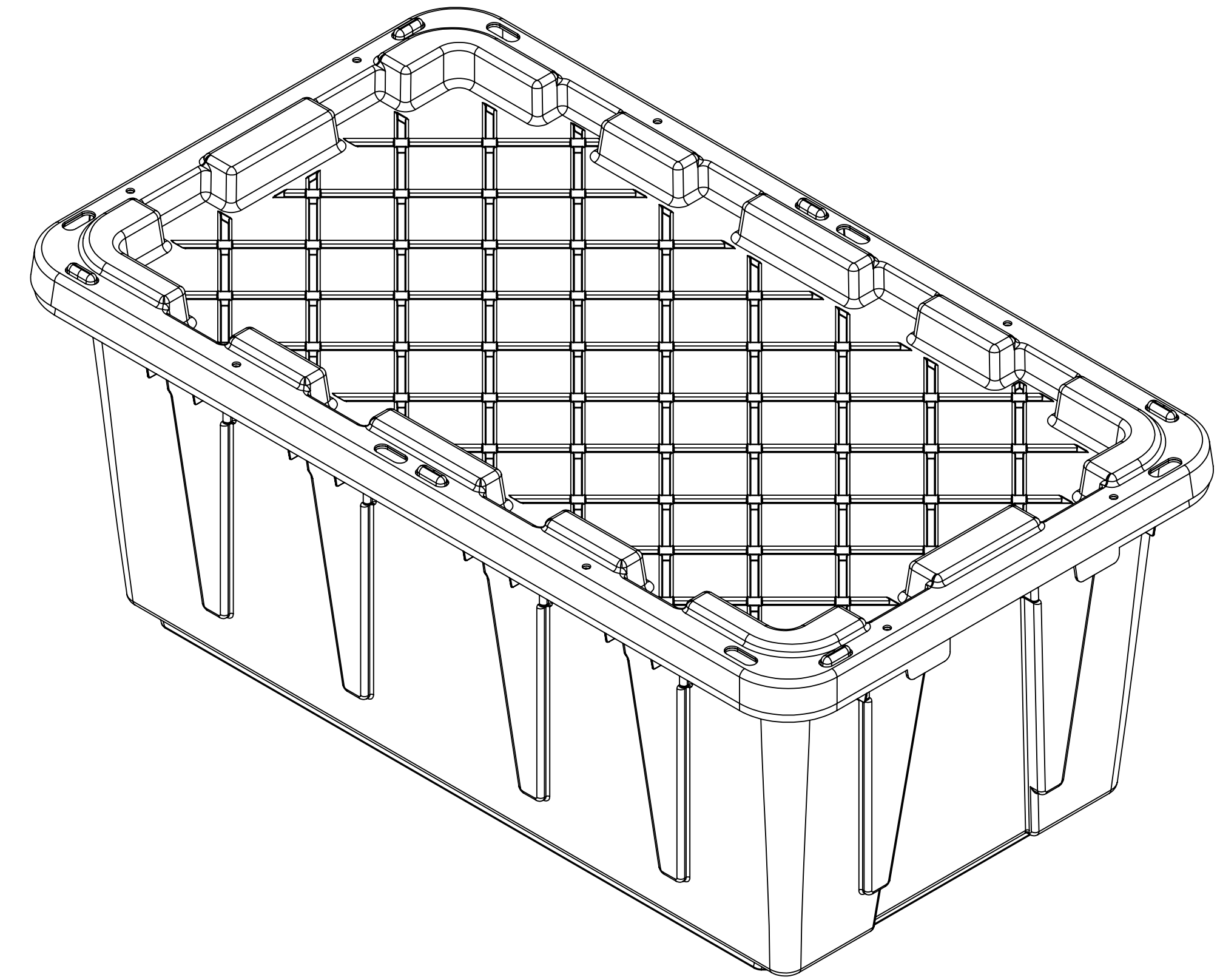

ITEM NO.	DESCRIPTION	WEIGHT	QTY.
1	38 GALLON BIN	7.78	1
2	38 GALLON LID	3.19	1

PROPRIETARY AND CONFIDENTIAL
THE INFORMATION CONTAINED IN THIS DRAWING IS THE SOLE PROPERTY OF CREATIVE PLASTIC CONCEPTS. ANY REPRODUCTION IN PART OR AS A WHOLE WITHOUT THE WRITTEN PERMISSION OF CREATIVE PLASTIC CONCEPTS IS PROHIBITED.

UNLESS OTHERWISE SPECIFIED:	NAME	DATE
DIMENSIONS ARE IN INCHES		
TOLERANCES:	DRAWN	
FRACTIONAL ±	CHECKED	
ANGULAR MATCH ±	ENG APPR.	
TWO PLACE DECIMAL ±	MFG APPR.	
THREE PLACE DECIMAL ±	Q.A.	
INTERPRET GEOMETRIC TOLERANCING PER:	COMMENTS:	
MATERIAL		
FINISH		
NEXT ASSY		
USED ON		
APPLICATION		

CREATIVE PLASTIC CONCEPTS

TITLE: **38 GALLON BIN ASSEMBLY**

SIZE DWG. NO. REV

SCALE: 1:4 WEIGHT: 10.96 SHEET 1 OF 1

